

StarLite IMAGE COMPRESSION RESULTS - 1200 x 1200 DPI

Uncompressed file size = 16 MBytes; Image dimensions = 10200 × 13200 pels

FONTS - Simple Text

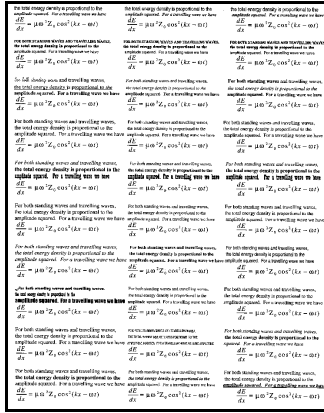

Output File Size = 783,848
Compression Ratio = 21.5

MP - Text and Simple Graphics

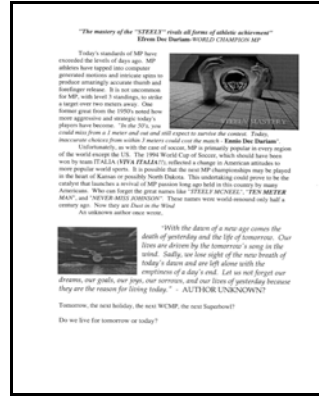

Output File Size = 86,525
Compression Ratio = 194.5

MATH - Simple Text and Linear

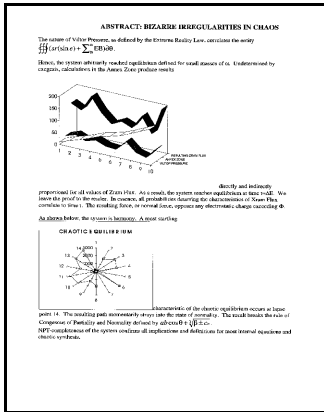

Output File Size = 79,245
Compression Ratio = 212.4

BENCH2 - Text and Graphics with Pictorials

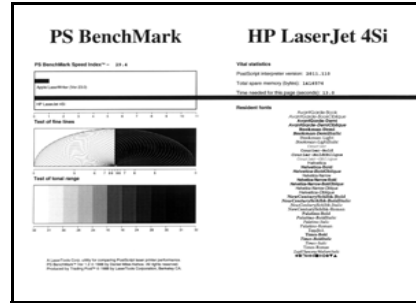

Output File Size = 424,995
Compression Ratio = 39.6

BALLS - Complex Graphics with Pictorials

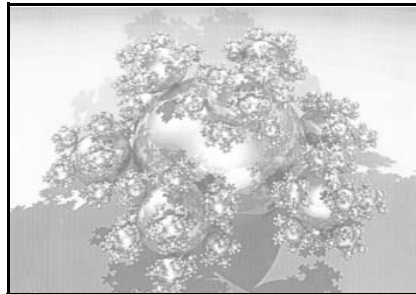

Output File Size = 3,665,167
Compression Ratio = 4.6

DECOMPRESSOR FOR MID-RANGE MULTIFUNCTION COPIER/PRINTER APPLICATIONS - AN EXAMPLE

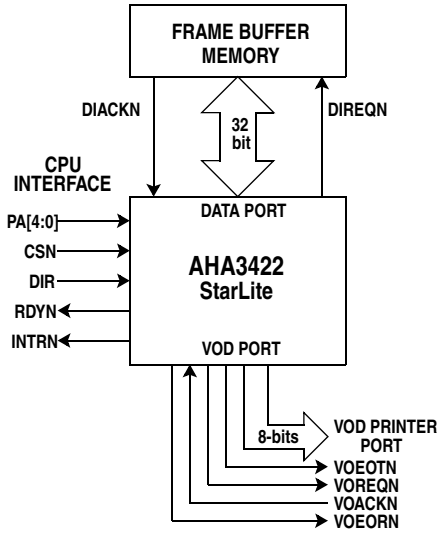

ABOUT AHA

Comtech AHA Corporation (AHA) develops and markets superior integrated circuits, boards, and intellectual property core technology for communications systems architects worldwide. AHA has been setting the standard in Forward Error Correction and Lossless Data Compression technology for many years and provides flexible, cost-effective solutions for today's growing bandwidth and reliability challenges. Comtech AHA Corporation is a wholly owned subsidiary of Comtech Telecommunications Corp. (NASDAQ: CMTL). For more information, visit www.aha.com.

ORDERING INFORMATION

PART NUMBER	DESCRIPTION
AHA3422A-033 PQC	16 MBytes/sec Lossless Decompressor IC



A subsidiary of Comtech Telecommunications Corporation

1126 Alturas Drive ■ Moscow ID 83843-8331

tel: 208.892.5600 ■ fax: 208.892.5601

e-mail: sales@aha.com ■ www.aha.com