

BCD-TO-SEVEN SEGMENT LATCH/DECODER/DRIVER

FEATURES

- ◆ Phase Input Signal Reproduced on Outputs for Liquid Crystal Display
- ◆ Latched Storage of Input Code
- ◆ Blanking Input for Display Intensity Modulation
- ◆ Readout Blanking for Illegal Input Combinations
- ◆ Pin Compatible with CD4056A (with Pin 7 Tied to V_{SS})

DESCRIPTION

The 4543B BCD-to-7 Segment Latch/Decoder/Driver is designed for use with liquid crystal readouts and is constructed with complementary MOS (CMOS) enhancement-mode devices. The circuit provides the functions of a 4-bit storage latch and a 8421 BCD-to-seven segment decoder and driver. The device has the capability to invert the logic levels of the output combinations. The Phase (Ph), Blanking (BI), and Latch Disable (LD) inputs are used to reverse the truth-table phase, blank the display, and store a BCD code, respectively. For liquid crystal readouts, a square wave is applied to the Ph input of the circuit and the electrically common backplane of the display. The outputs of the circuit are connected directly to the segments of the readout. For other types of readouts, such as light-emitting diode (LED), incandescent, gas discharge, and fluorescent readouts, connection diagrams are given on this data sheet.

Applications include instrument (e.g., counter,

TRUTH TABLE

INPUTS				OUTPUTS							
LD	BI	Ph*	D C B A	a	b	c	d	e	f	g	Display
X	1	0	X X X X	0	0	0	0	0	0	0	Blank
1	0	0	0 0 0 0	1	1	1	1	1	0	0	0
1	0	0	0 0 0 1	0	1	1	0	0	0	0	1
1	0	0	0 0 1 0	1	1	0	1	0	1	0	2
1	0	0	0 0 1 1	1	1	1	0	0	1	0	3
1	0	0	0 1 0 0	0	1	1	0	0	1	1	4
1	0	0	0 1 0 1	1	0	1	1	0	1	1	5
1	0	0	0 1 1 0	1	0	1	1	1	1	1	6
1	0	0	0 1 1 1	1	1	1	0	0	0	0	7
1	0	0	1 0 0 0	1	1	1	1	1	1	1	8
1	0	0	1 0 0 1	1	1	1	1	0	1	1	9
1	0	0	1 0 1 0	0	0	0	0	0	0	0	Blank
1	0	0	1 0 1 1	0	0	0	0	0	0	0	Blank
1	0	0	1 1 0 0	0	0	0	0	0	0	0	Blank
1	0	0	1 1 0 1	0	0	0	0	0	0	0	Blank
1	0	0	1 1 1 0	0	0	0	0	0	0	0	Blank
1	0	0	1 1 1 1	0	0	0	0	0	0	0	Blank
0	0	0	X X X X	**	**	**	**	**	**	**	**
1	1	1	1	Inverse of Output Combinations Above						Display as above	

X = Don't care
 1 = Above Combinations
 * = For liquid crystal readouts, apply a square wave to Ph. For common cathode LED readouts, select Ph = 0. For common anode LED readouts, select Ph = 1.
 ** = Depends upon the BCD code previously applied when LD = 1

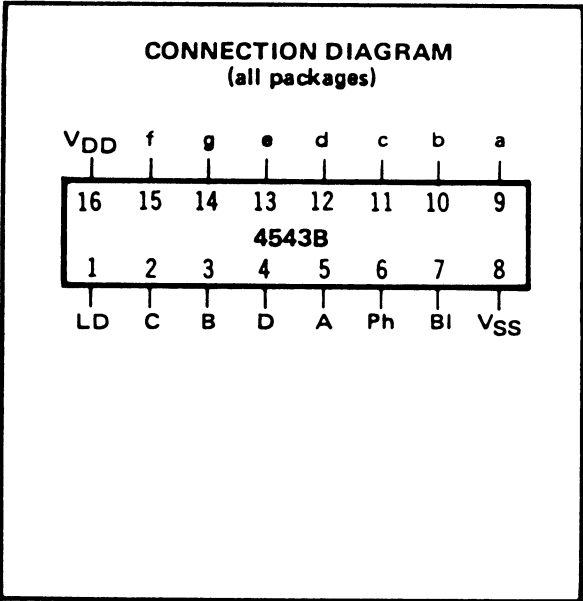

RECOMMENDED OPERATING CONDITIONS

For maximum reliability:

DC Supply Voltage	V _{DD} - V _{SS}	3 to 15	Vdc
Operating Temperature	T _A	-55 to +125	°C
		-40 to +85	°C

DVM, etc.) display driver, computer/calculator display driver, cockpit display driver, and various clock, watch, and timer uses.

BLOCK DIAGRAM

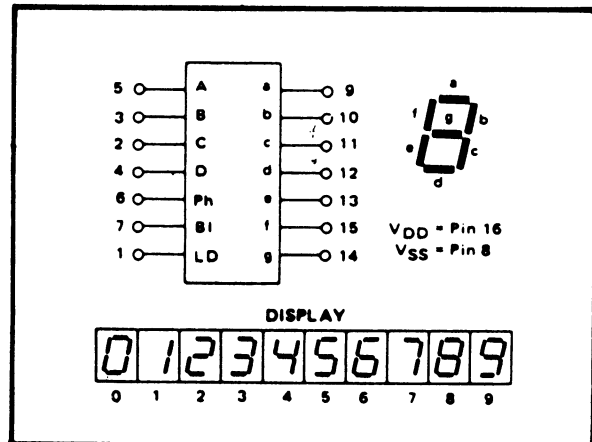

ELECTRICAL CHARACTERISTICS

STATIC CHARACTERISTICS¹

PARAMETER	V _{DD} (Vdc)	CONDITIONS	T _{LOW} ²		+25°C			T _{HIGH} ²		Units
			Min.	Max.	Min.	Typ.	Max.	Min.	Max.	
QUIESCENT DEVICE CURRENT	I _{DD}	V _{IN} = V _{SS} or V _{DD} All valid input combinations	—	5	—	0.05	5	—	150	μA _{dc}
			—	10	—	0.1	10	—	300	
			—	20	—	0.2	20	—	600	

NOTES: ¹ Remaining Static Electrical Characteristics are listed under "4000B Series Family Specifications".

² T_{LOW} = -55°C for C
= -40°C for E
T_{HIGH} = +125°C for C
= + 85°C for E

DYNAMIC CHARACTERISTICS (C_L = 50pF, T_A = 25°C)

PARAMETER	V _{DD} (Vdc)	Min.	Typ.	Max.	Units
PROPAGATION DELAY TIME	t _{PLH} , t _{PHL}	5	—	550	1100
		10	—	210	420
		15	—	160	320
OUTPUT TRANSITION TIME	t _{TLH} , t _{THL}	5	—	100	200
		10	—	50	100
		15	—	40	80
MINIMUM DATA INPUT SETUP TIME	t _{setup}	5	—	-40	0
		10	—	-15	0
		15	—	-10	0
MINIMUM DATA INPUT HOLD TIME	t _{hold}	5	—	40	80
		10	—	15	30
		15	—	10	20
MINIMUM LD PULSE WIDTH	PW _{LD}	5	—	125	250
		10	—	50	100
		15	—	40	80

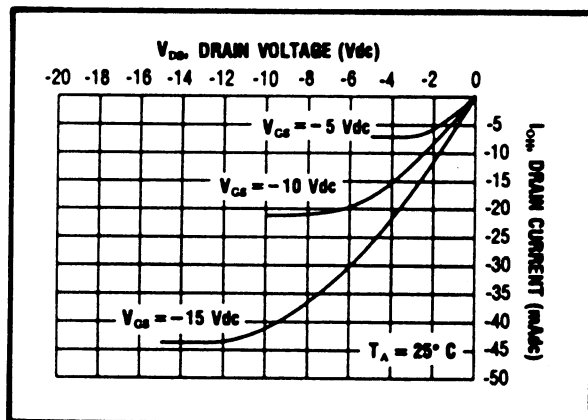

Typical P-Channel
Source Current Characteristics

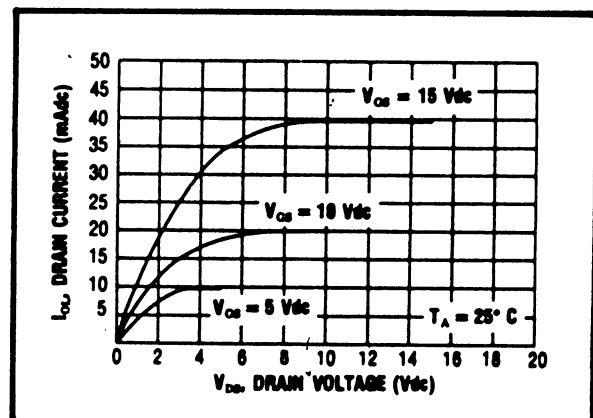

Typical N-Channel
Sink Current Characteristics

LOGIC DIAGRAM

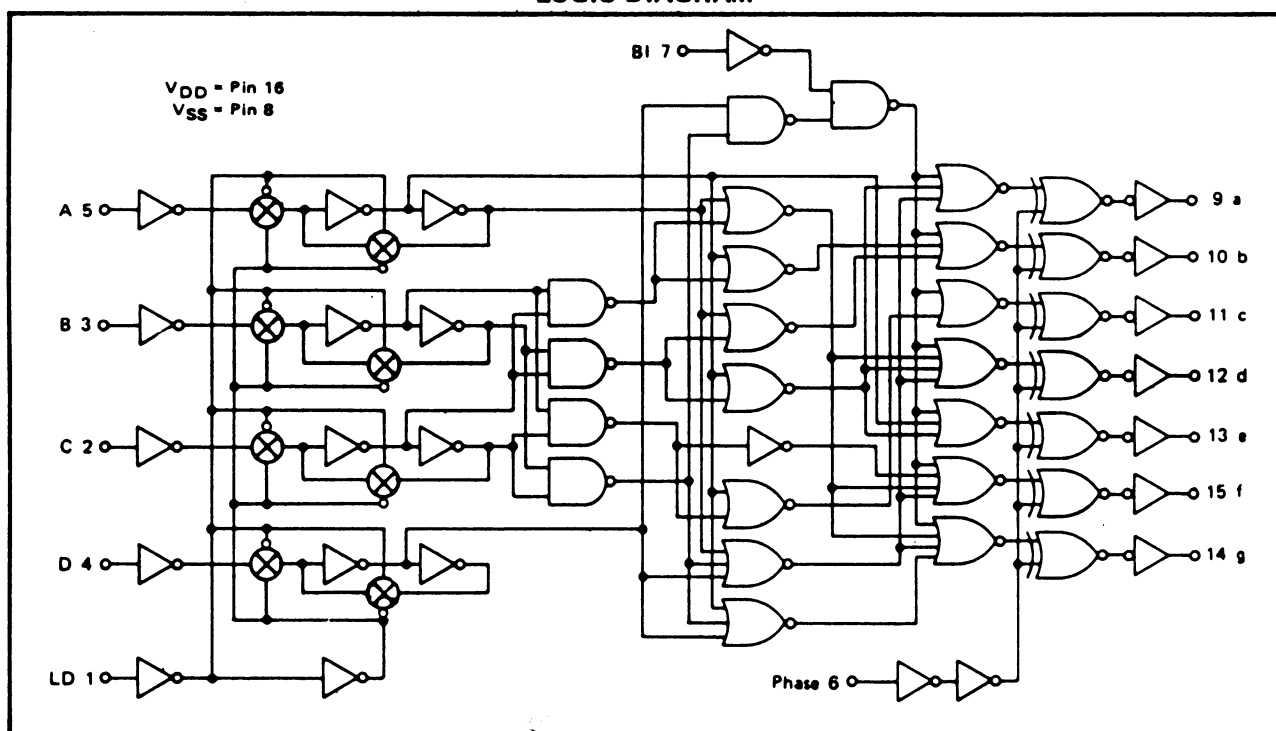

APPLICATIONS INFORMATION

CONNECTIONS TO VARIOUS DISPLAY READOUTS

