

**NEC****3 V, WIDEBAND  
MEDIUM POWER SI MMIC AMPLIFIER****UPC2762T  
UPC2763T****FEATURES**

- 7 dBm P<sub>1dB</sub> TYPICAL AT 1.9 GHz
- **LOW VOLTAGE:** 3 Volts
- **WIDE BANDWIDTH:** 2.9 GHz at -3 dB (UPC2762T)
- **HIGH GAIN:** 20 dB at 1.9 GHz (UPC2763T)
- **SUPER SMALL PACKAGE**
- **TAPE AND REEL PACKAGING OPTION AVAILABLE**

**DESCRIPTION**

The UPC2762T and UPC2763T are Silicon Monolithic integrated circuits which are manufactured using the NESAT III process. The NESAT III process produces transistors with  $f_t$  approaching 20 GHz. These amplifiers were designed for 900 MHz and 1.9 GHz receivers in cellular, cordless telephone and PCN applications. Operating on a 3 volt supply these ICs are ideally suited for hand-held, portable designs.

NEC's stringent quality assurance and test procedures ensure the highest reliability and performance.

**ELECTRICAL CHARACTERISTICS** ( $T_A = 25^\circ\text{C}$ ,  $Z_L = Z_S = 50\Omega$ ,  $V_{CC} = 3.0\text{ V}$ )

PART NUMBER PACKAGE OUTLINE			UPC2762T T06			UPC2763T T06		
SYMBOLS	PARAMETERS AND CONDITIONS	UNITS	MIN	TYP	MAX	MIN	TYP	MAX
I <sub>CC</sub>	Circuit Current (no signal)	mA		27	35		27	35
G <sub>s</sub>	Small Signal Gain, f = 900 MHz f = 1900 MHz	dB dB	11 11.5	13 14.5	16 17.5	16 16.5	20 19.5	23 22.5
f <sub>u</sub> <sup>1</sup>	Upper Limit Operating Frequency (The gain at f <sub>u</sub> is 3 dB down from the gain at 0.1 GHz)	GHz	2.7	2.9		2.0	2.4	
P <sub>1dB</sub>	Output Power at 1 dB Compression Point, f = 900 MHz f = 1900 MHz	dBm dBm	+5.5 +4.5	+8 +7		+7 +4	+9.5 +6.5	
P <sub>SAT</sub>	Saturated Output Power, f = 900 MHz f = 1900 MHz	dBm dBm		9 8.5			11 8	
NF	Noise Figure, f = 900 MHz f = 1900 MHz	dB dB		6.5 7	8 8.5		5.5 5.5	7.0 7.0
RL <sub>IN</sub>	Input Return Loss, f = 900 MHz f = 1900 MHz	dB dB	6 5.5	9 8.5		8 9	11 12	
RL <sub>OUT</sub>	Output Return Loss, f = 900 MHz f = 1900 MHz	dB dB	8 9	11 12		5 6	8 9	
ISOL	Isolation, f = 900 MHz f = 1900 MHz	dB dB	22 20	27 25		25 24	30 29	
OIP3	SSB Output Third Order Intercept Point f = 900, 902 MHz f = 1900, 1902 MHz	dBm dBm		+12 +9			+17 +11	
R <sub>TH</sub> (J-A)	Thermal Resistance (Junction to Ambient) Free Air Mounted on a 50 x 50 x 1.6 mm epoxy glass PWB	$^\circ\text{C/W}$ $^\circ\text{C/W}$						620 230

Note:

1. The gain at f<sub>u</sub> is 3 dB down from the gain at 100 MHz.

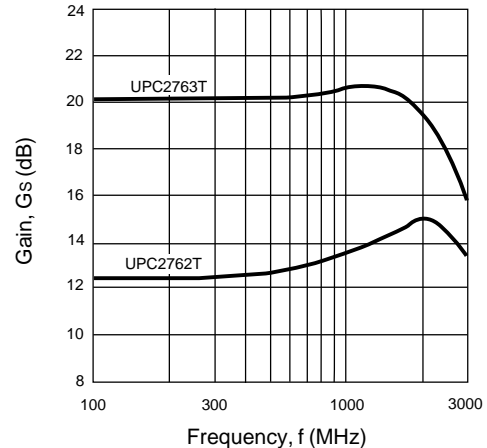
**GAIN vs. FREQUENCY** $V_{CC} = 3.0\text{ V}$ ,  $I_{CC} = 27\text{ mA}$ 

**ABSOLUTE MAXIMUM RATINGS<sup>1</sup>** (T<sub>A</sub> = 25°C)

SYMBOLS	PARAMETERS	UNITS	RATINGS
V <sub>CC</sub>	Supply Voltage	V	3.6
I <sub>CC</sub>	Total Supply Current	mA	70
P <sub>IN</sub>	Input Power	dBm	+10
P <sub>T</sub>	Total Power Dissipation <sup>2</sup>	mW	280
T <sub>OP</sub>	Operating Temperature	°C	-40 to +85
T <sub>STG</sub>	Storage Temperature	°C	-55 to +150

Notes:

1. Operation in excess of any one of these parameters may result in permanent damage.
2. Mounted on a 50 x 50 x 1.6 mm epoxy glass PWB (T<sub>A</sub> = 85°C).

**RECOMMENDED OPERATING CONDITIONS**

SYMBOLS	PARAMETERS	UNITS	MIN	TYP	MAX
V <sub>CC</sub>	Supply Voltage	V	2.7	3	3.3
T <sub>OP</sub>	Operating Temperature	°C	-40	25	85

**TEST CIRCUIT**

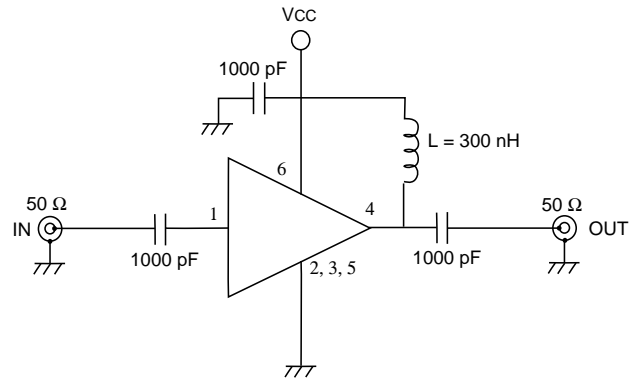

**TYPICAL PERFORMANCE CURVES** (T<sub>A</sub> = 25°C)

**UPC2762T/63T**  
**SUPPLY CURRENT vs.**  
**SUPPLY VOLTAGE**

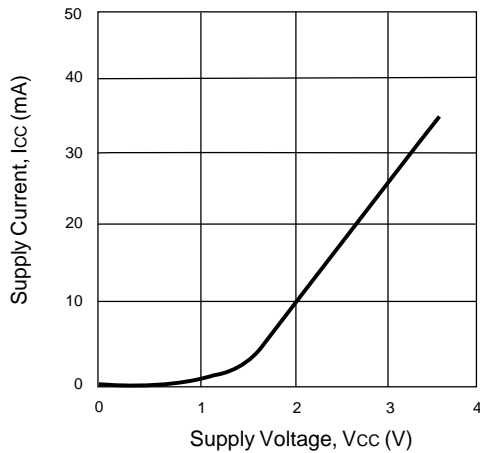

**UPC2762T/63T**  
**SUPPLY CURRENT vs.**  
**OPERATING TEMPERATURE**

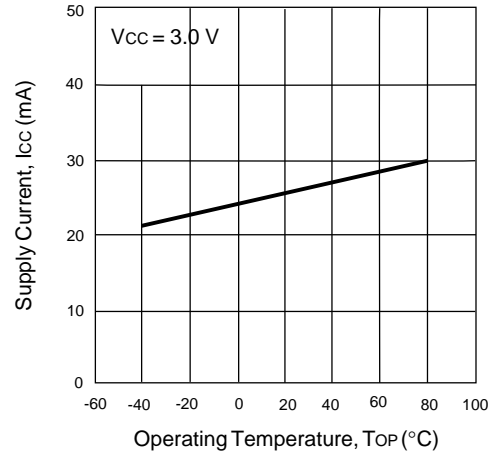

**UPC2762T**  
**NOISE FIGURE AND GAIN vs.**  
**FREQUENCY AND VOLTAGE**

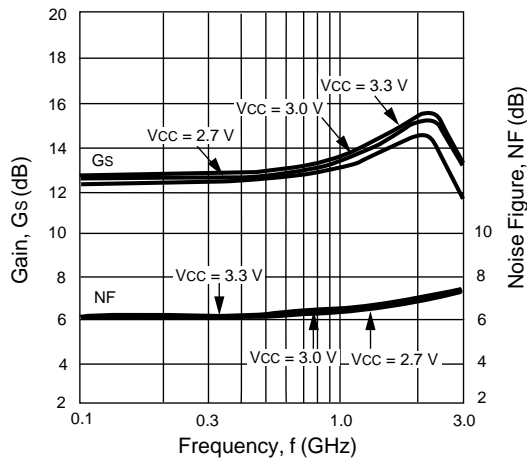

**UPC2763T**  
**NOISE FIGURE AND GAIN vs.**  
**FREQUENCY AND VOLTAGE**

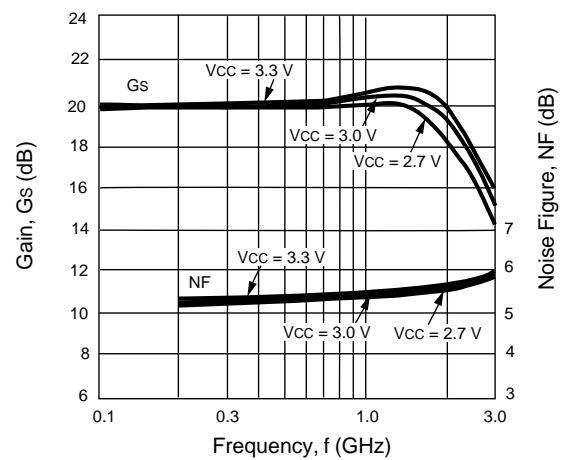

**TYPICAL PERFORMANCE CURVES** ( $T_A = 25^\circ\text{C}$ )

**UPC2762T**  
**GAIN vs. FREQUENCY AND TEMPERATURE**

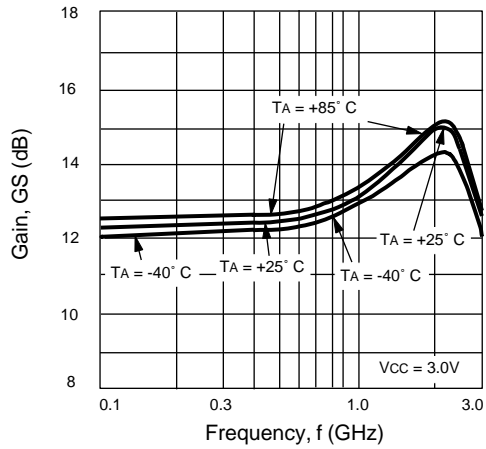

**UPC2763T**  
**GAIN vs. FREQUENCY AND TEMPERATURE**

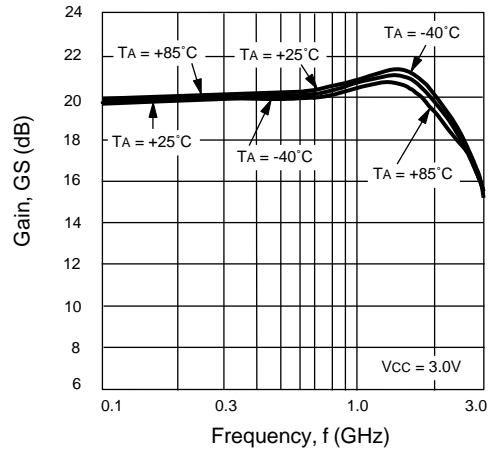

**UPC2762T**  
**INPUT AND OUTPUT**  
**RETURN LOSS vs. FREQUENCY**

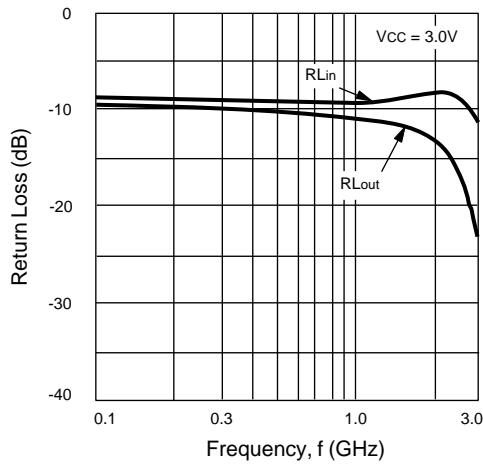

**UPC2763T**  
**INPUT AND OUTPUT**  
**RETURN LOSS vs. FREQUENCY**

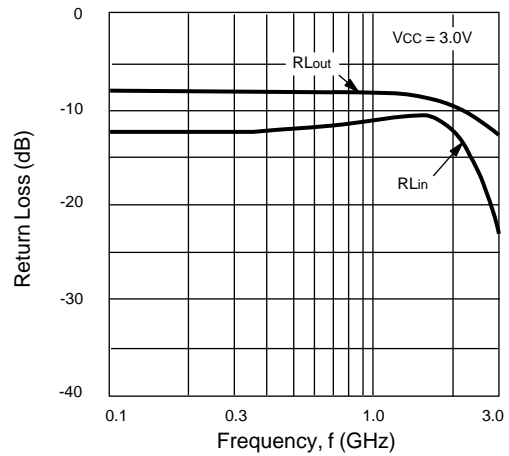

**UPC2762T**  
**ISOLATION vs. FREQUENCY**

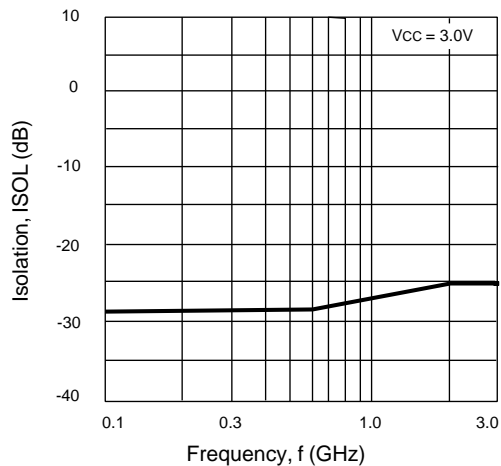

**UPC2763T**  
**ISOLATION vs. FREQUENCY**

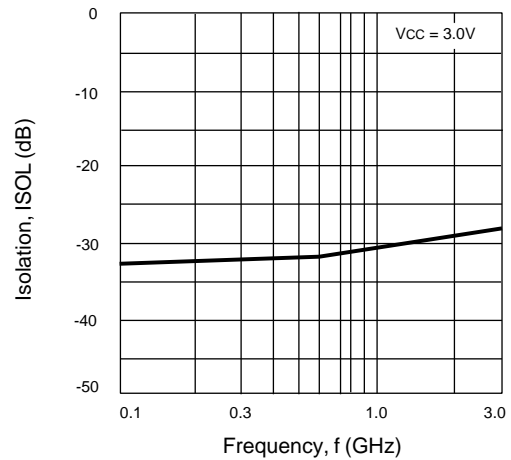

**TYPICAL PERFORMANCE CURVES** ( $T_A = 25^\circ\text{C}$ )

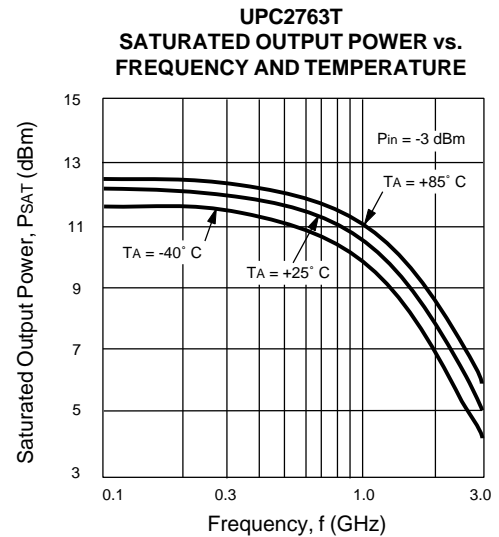
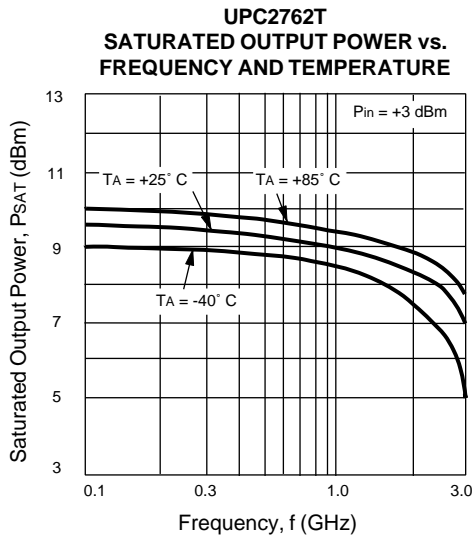
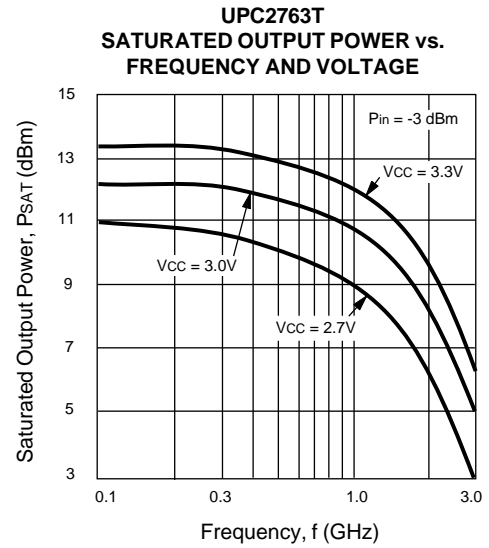
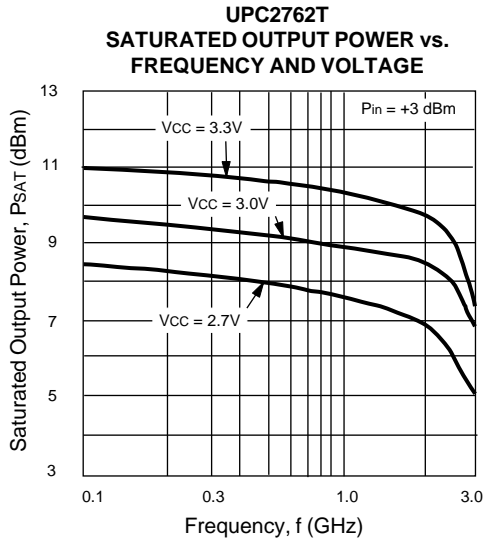
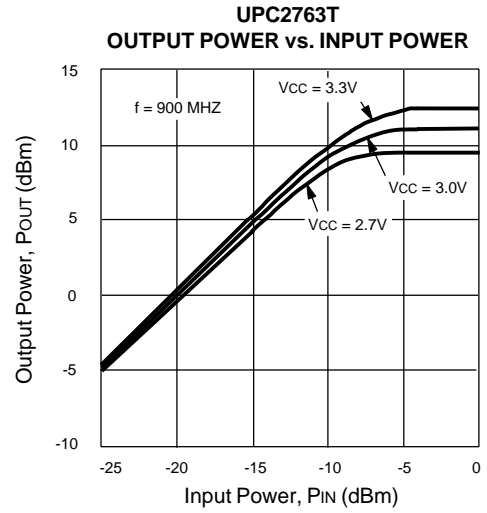
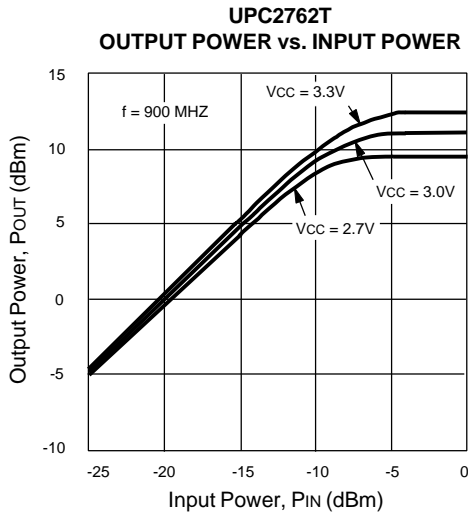

**TYPICAL SCATTERING PARAMETERS** ( $T_A = 25^\circ\text{C}$ )

**UPC2762T**  
**S<sub>11</sub> vs. FREQUENCY**  
( $V_{CC} = 3.0\text{ V}$ )

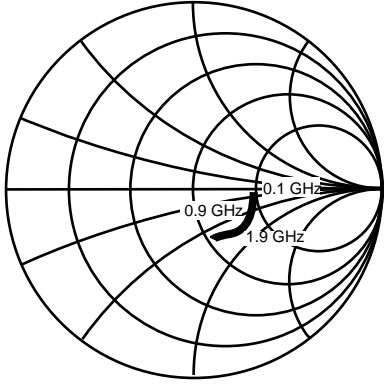

**UPC2762T**  
**S<sub>22</sub> vs. FREQUENCY**  
( $V_{CC} = 3.0\text{ V}$ )

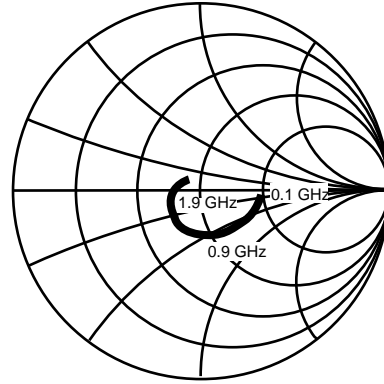

**UPC2763T**  
**S<sub>11</sub> vs. FREQUENCY**  
( $V_{CC} = 3.0\text{ V}$ )

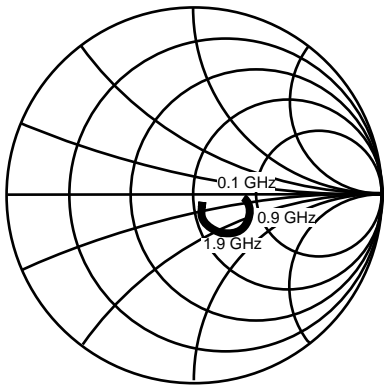

**UPC2763T**  
**S<sub>22</sub> vs. FREQUENCY**  
( $V_{CC} = 3.0\text{ V}$ )

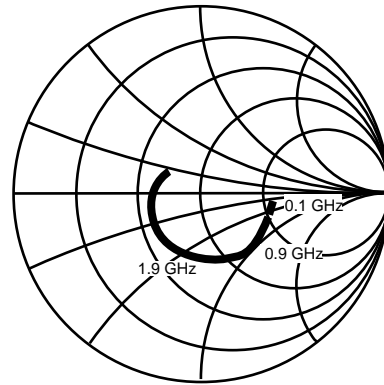

## OUTLINE DIMENSIONS (Units in mm)

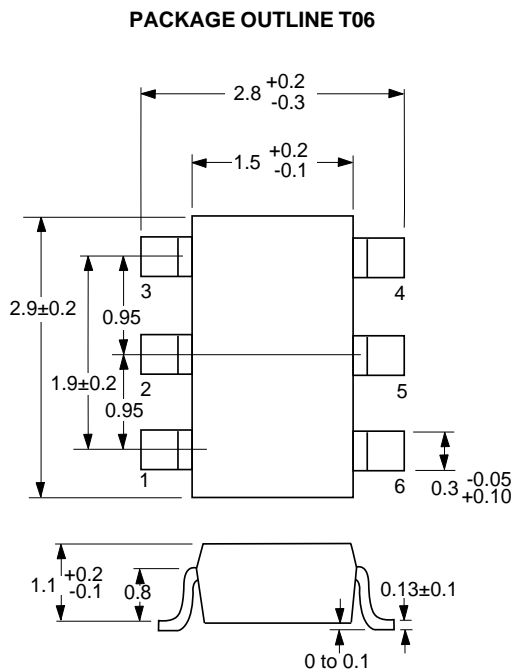

Note:  
All dimensions are typical unless otherwise specified.

## EQUIVALENT CIRCUIT

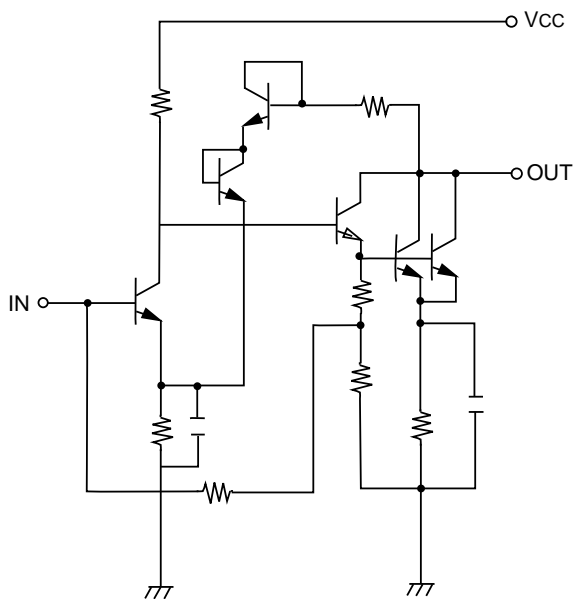

## LEAD CONNECTIONS

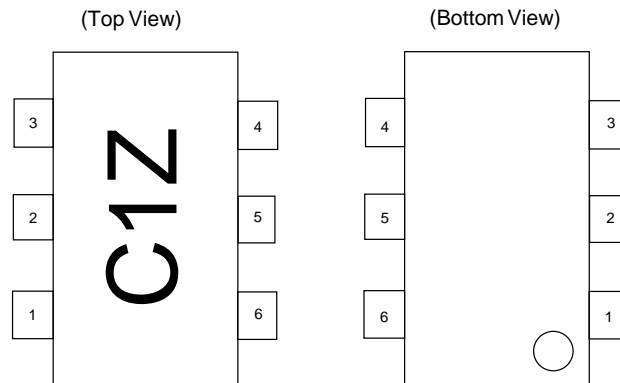

1. INPUT
2. GND
3. GND
4. OUTPUT
5. GND
6. Vcc

Note: Package Marking  
C1Z: UPC2762T  
C2A: UPC2763T

## RECOMMENDED P.C.B. LAYOUT (Units in mm)

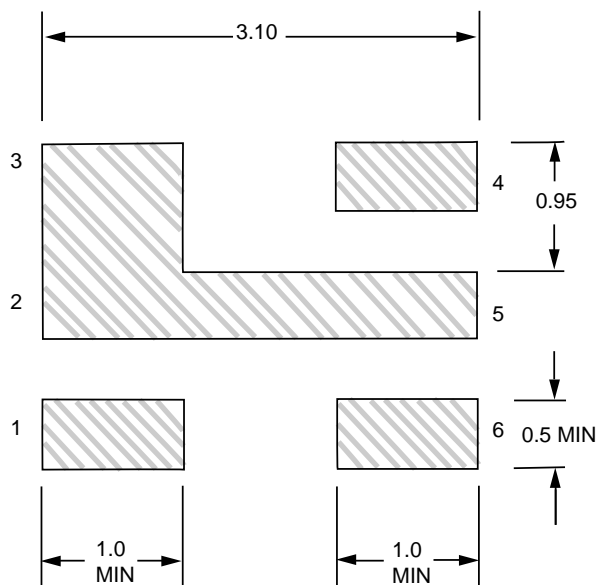

## ORDERING INFORMATION

PART NUMBER	QTY
UPC2762T-E3	3K/Reel
UPC2763T-E3	3K/Reel

Note:  
Embossed Tape, 8 mm wide.

EXCLUSIVE AGENT FOR **NEC Corporation** RF & MICROWAVE SEMICONDUCTOR PRODUCTS - U.S. & CANADA

CALIFORNIA EASTERN LABORATORIES, INC • Headquarters • 4590 Patrick Henry Drive • Santa Clara, CA 95054-1817 • (408) 988-3500 • Telex 34-6393/FAX (408) 988-0279  
DATA SUBJECT TO CHANGE WITHOUT NOTICE