



3.0A LOW DROPOUT LINEAR REGULATOR

DESCRIPTION

The **LR3966** is a low-noise, low-dropout linear regulator operated from a 2.5V to 6V input voltage and is guaranteed to deliver 3A output current. Wide range of preset output voltage options are available. Built-in low on-resistance transistor provides low dropout voltage and large output current. The **LR3966** is designed and optimized for battery-powered systems to work with low noise.

The **LR3966** is developed on a CMOS process technology which allows low quiescent current operation independent of output load current.. This CMOS process also allows the **LR3966** to operate under extremely low dropout conditions.

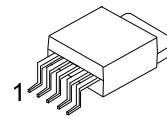

TO-252-5

FEATURES

- * 3A Guaranteed Output Current
- * Ultra Low Dropout Voltage
- * Low Ground Pin Current
- * Low Temperature Coefficient
- * Current Limiting Protection
- * Thermal Shutdown Protection
- * Excellent Line/Load Transient
- * SENSE Option Improves Load Regulation

ORDERING INFORMATION

Ordering Number		Package	Packing
Lead Free	Halogen Free		
LR3966L-xx-TN5-D-R	LR3966G-xx-TN5-D-R	TO-252-5	Tape Reel

<p>LR3966L-xx-TN5-R</p>	<ul style="list-style-type: none"> (1)Packing Type (2)Package Type (3)Output Voltage Code (4)Lead Free 	<ul style="list-style-type: none"> (1) R: Tape Reel (2) TN5: TO-252-5 (3) xx: refer to Marking Information (4) L:Lead Free, G: Halogen Free
-------------------------	--	---

■ MARKING INFORMATION

PACKAGE	VOLTAGE CODE	MARKING
TO-252-5	33 :3.3V	<p>UTC LR3966 XX 33 L: Lead Free G: Halogen Free Date Code LOT Code 1 2 3 4 5</p>

■ PIN CONFIGURATION

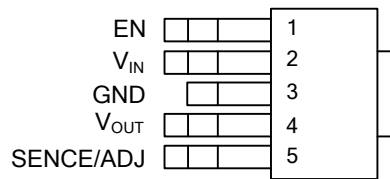

■ PIN DESCRIPTION

PIN NO.	PIN NAME	DESCRIPTION
1	EN	Active-Low Shutdown Input. Connect EN to V_{IN} for normal operation.
2	V_{IN}	Power Input Voltage. Supply voltage can range from 2.5V to 6V. Bypass with a 68 μ F capacitor to GND.
3	GND	Ground
4	V_{OUT}	Output Voltage
5	ADJ	Voltage-adjust Input. Connect ADJ to GND for preset output. Connect an external resistive voltage-divider from V_{OUT} to ADJ to set the output voltage between 1.145V and 5V.
	SENSE	Remote sense pin.

■ BLOCK DIAGRAM

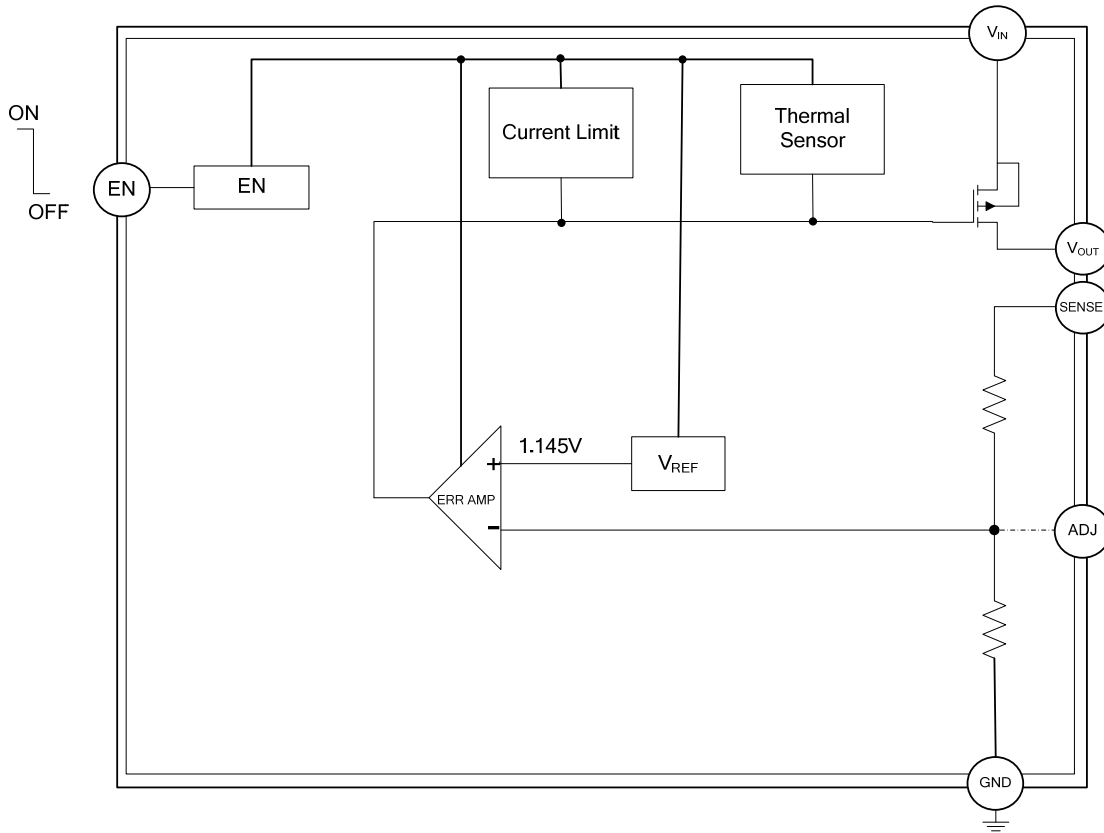

■ ABSOLUTE MAXIMUM RATING (T_A=25°C)

PARAMETER	SYMBOL	RATINGS	UNIT
Input Supply Voltage(Survival)	V _{IN}	0~7.0	V
Enable Input Voltage(Survival)	V _{EN}	0~7.0	V
Power Dissipation	P _D	925	mW
Operation Junction Temperature Range	T _{OPR}	-40 ~ +125	°C
Storage Temperature Range	T _{STG}	-65 ~ +150	°C

Note: Absolute maximum ratings are those values beyond which the device could be permanently damaged.

Absolute maximum ratings are stress ratings only and functional device operation is not implied.

■ ELECTRICAL CHARACTERISTICS

Unless otherwise specified: V_{IN}=V_{O(NOM)}+1V or V_{IN}=2.5V whichever is greater, I_L=10mA, C_{IN}=68μF, C_{OUT}=33μF, V_{EN}=V_{IN}-0.3V. Limits in standard typeface are for T_J=25°C, and limits in **boldface type** apply over the **full operating temperature range**.

PARAMETER	SYMBOL	TEST CONDITION	MIN	TYP	MAX	UNITS
Output Voltage Tolerance	V _{OUT}	10mA<I _L <3A V _{OUT} +1V<V _{IN} <6V	-2		2	%
			-3		3	
Adjustable Pin Voltage (ADJ version)	V _{ADJ}	10mA<I _L <1.5A V _{OUT} +1.5V<V _{IN} <6V	1.117	1.145	1.174	V
			1.110		1.188	
Line Regulation (Note 1)	REGLINE	V _{OUT} +1V≤V _{IN} ≤6V		0.08	0.18	%V
					0.22	
Load Regulation (Note 1,2)	REGLOAD	10mA≤I _L ≤3A		0.25	0.55	%
					0.6	
Dropout Voltage (Note 3)	V _{DROP}	I _L =300mA		50	65	mV
					80	
		I _L =3A		480	580	
					680	
Ground Pin Current	I _{GND1}	I _L =300mA		60	120	μA
		I _L =3A		60	120	
	I _{GND2}	V _{EN} <0.2V		60	120	μA
Output Peak Current	I _{PEAK}		4.5	4.5		A
			3.5			
EnableThreshold	V _{IH}	Output=High	V _{IN} /2+0.5	V _{IN}		V
	V _{IL}	Output=Low		0	V _{IN} /2-0.5	
Enable Input Current	I _{EN}	V _{EN} =V _{IN}		0.05	2	μA
Thermal Shutdown Temperature	T _{SD}			165		°C
Thermal Shutdown Hysteresis	DT _{SD}			10		°C

Note:

1. Output voltage line regulation is defined as the change in output voltage from the nominal value resulting from a change in the input line voltage. Output voltage load regulation is defined as the change in output voltage from the nominal value as the load current increases from no load to full load.
2. Regulation is measured at constant junction temperature by using a 20ms current pulse. Devices are tested for load regulation in the load range from 10mA to 3.0A
3. Dropout voltage is defined as the voltage from the input to output when output is 2% below the nominal value. Dropout voltage specification applies only to output voltages of 2.5V and above.

■ TYPICAL APPLICATION CIRCUIT

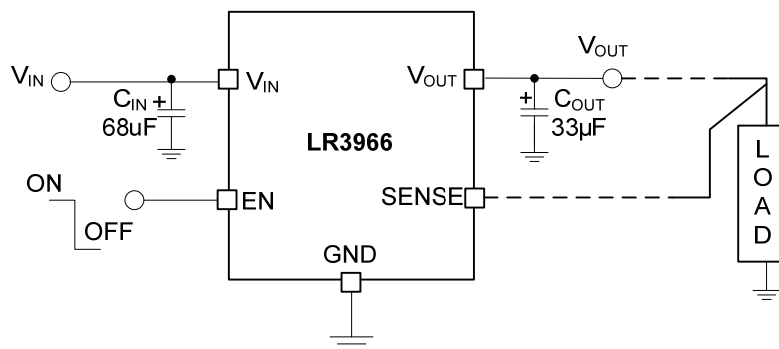
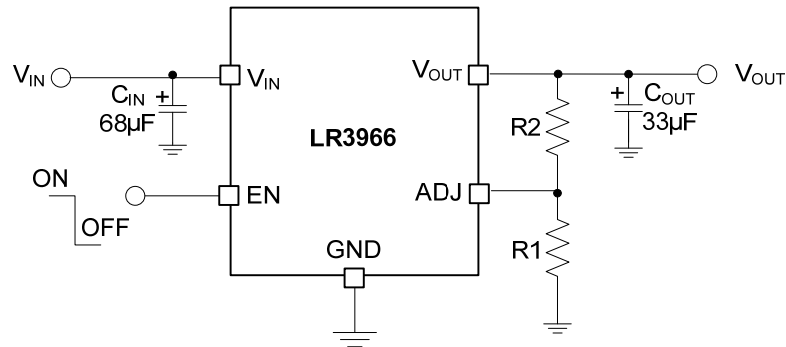

***LR3966** can deliver a continuous current of 3.0A over the full operating temperature. However, the output current is limited by the restriction of power dissipation which differs from packages. A heat sink may be required depending on the maximum power dissipation and maximum ambient temperature of application. With respect to the applied package, the maximum output current of 3.0A may be still undeliverable.

*When a Pull-Up resistor is connected between V_{EN} terminal and V_{EN} Signal (or V_{IN} line), the resistance of the Pull-Up resistor should be kept under 10k Ω .

UTC assumes no responsibility for equipment failures that result from using products at values that exceed, even momentarily, rated values (such as maximum ratings, operating condition ranges, or other parameters) listed in products specifications of any and all UTC products described or contained herein. UTC products are not designed for use in life support appliances, devices or systems where malfunction of these products can be reasonably expected to result in personal injury. Reproduction in whole or in part is prohibited without the prior written consent of the copyright owner. The information presented in this document does not form part of any quotation or contract, is believed to be accurate and reliable and may be changed without notice.