

DATA SHEET



PCA9530 2-bit I²C LED dimmer

Product data sheet
Supersedes data of 2004 Sep 14

2004 Oct 01

2-bit I²C LED dimmer

PCA9530



FEATURES

- 2 LED drivers (on, off, flashing at a programmable rate)
- 2 selectable, fully programmable blink rates (frequency and duty cycle) between 0.591 Hz and 152 Hz (1.69 seconds and 6.58 milliseconds)
- 256 brightness steps
- Input/output not used as LED drivers can be used as regular GPIOs
- Internal oscillator requires no external components
- I²C interface logic compatible with SMBus
- Internal power-on reset
- Noise filter on SCL/SDA inputs
- Active LOW reset input
- 2 open drain outputs directly drive LEDs to 25 mA
- Edge rate control on outputs
- No glitch on power-up
- Supports hot insertion
- Low stand-by current
- Operating power supply voltage range of 2.3 V to 5.5 V
- 0 to 400 kHz clock frequency
- ESD protection exceeds 2000 V HBM per JESD22-A114, 150 V MM per JESD22-A115 and 1000 V CDM per JESD22-C101
- Latch-up testing is done to JEDEC Standard JESD78 which exceeds 100 mA
- Packages offered: SO8, TSSOP8 (MSOP8)

DESCRIPTION

The PCA9530 is a 2-bit I²C and SMBus I/O expander optimized for dimming LEDs in 256 discrete steps for Red/Green/Blue (RGB) color mixing and back light applications.

The PCA9530 contains an internal oscillator with two user programmable blink rates and duty cycles coupled to the output PWM. The LED brightness is controlled by setting the blink rate high enough (> 100 Hz) that the blinking can not be seen and then using the duty cycle to vary the amount of time the LED is on and thus the average current through the LED.

ORDERING INFORMATION

PACKAGES	TEMPERATURE RANGE	ORDER CODE	TOPSIDE MARK	DRAWING NUMBER
8-Pin Plastic SO	-40 °C to +85 °C	PCA9530D	PCA9530	SOT96-1
8-Pin Plastic TSSOP (MSOP)	-40 °C to +85 °C	PCA9530DP	9530	SOT505-1

Standard packing quantities and other packaging data are available at www.standardproducts.philips.com/packaging. I²C is a trademark of Philips Semiconductors Corporation.

The initial setup sequence programs the two blink rates/duty cycles for each individual PWM. From then on, only one command from the bus master is required to turn individual LEDs ON, OFF, BLINK RATE 1 or BLINK RATE 2. Based on the programmed frequency and duty cycle, BLINK RATE 1 and BLINK RATE 2 will cause the LEDs to appear at a different brightness or blink at periods up to 1.69 second. The open drain outputs directly drive the LEDs with maximum output sink current of 25 mA per bit and 50 mA per package.

To blink LEDs at periods greater than 1.69 second the bus master (MCU, MPU, DSP, chipset, etc.) must send repeated commands to turn the LED on and off as is currently done when using normal I/O Expanders like the Philips PCF8574 or PCA9554. Any bits not used for controlling the LEDs can be used for General Purpose Parallel Input/Output (GPIO) expansion which provides a simple solution when additional I/O is needed for ACPI power switches, sensors, pushbuttons, alarm monitoring, fans, etc.

The active LOW hardware reset pin (**RESET**) and Power-On Reset (POR) initialize the registers to their default state causing the bits to be set HIGH (LED off).

One hardware address pin on the PCA9530 allows two devices to operate on the same bus.

PIN CONFIGURATION

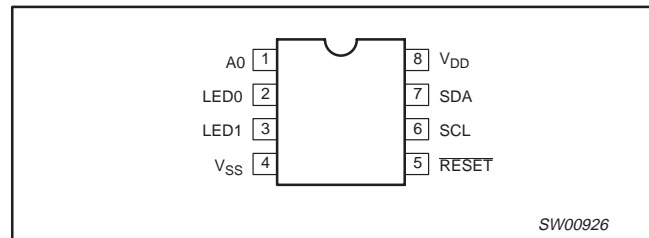

Figure 1. Pin configuration

PIN DESCRIPTION

PIN NUMBER	SYMBOL	FUNCTION
1	A0	Address input 0
2	LED0	LED driver 0
3	LED1	LED driver 1
4	V _{SS}	Supply ground
5	RESET	Active LOW reset input
6	SCL	Serial clock line
7	SDA	Serial data line
8	V _{DD}	Supply voltage

2-bit I²C LED dimmer

PCA9530

BLOCK DIAGRAM

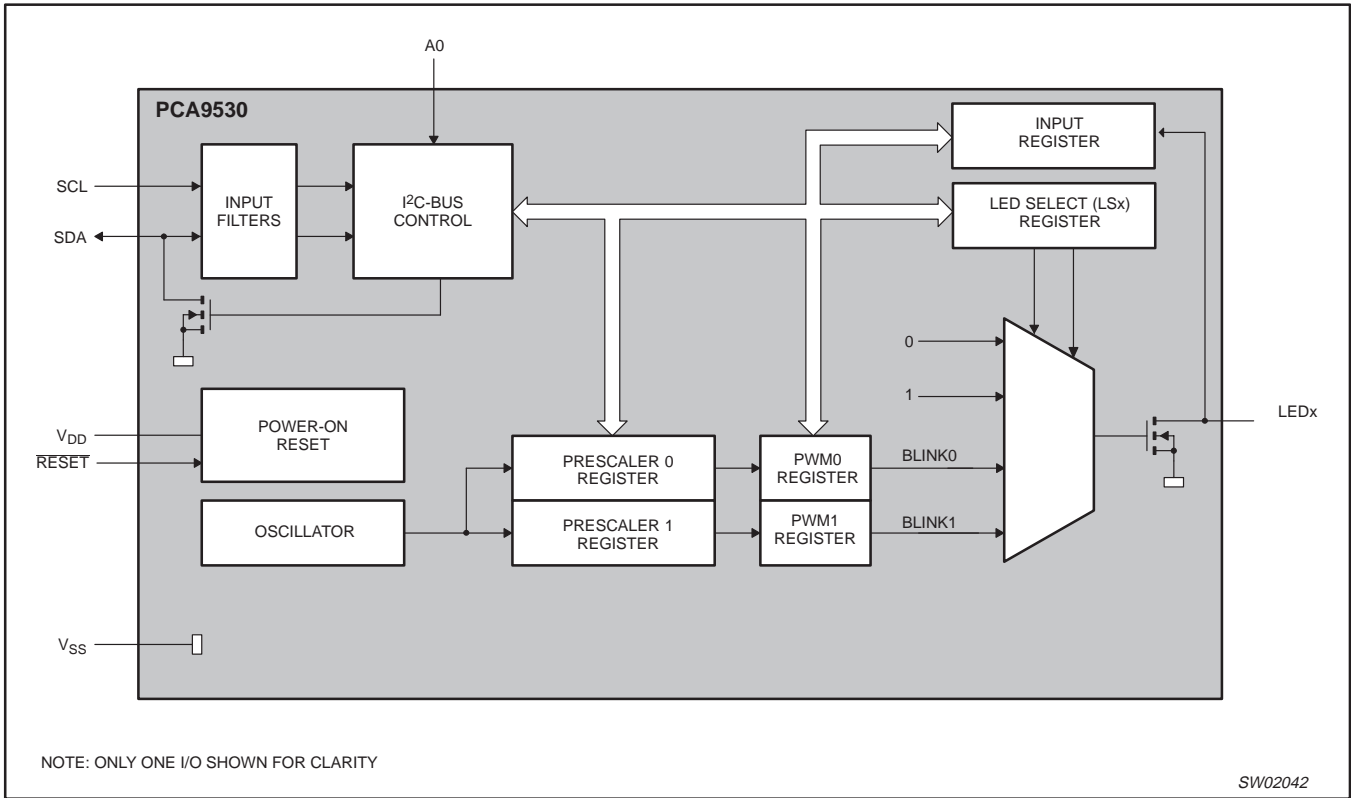

Figure 2. Block diagram

2-bit I²C LED dimmer

PCA9530

DEVICE ADDRESSING

Following a START condition the bus master must output the address of the slave it is accessing. The address of the PCA9530 is shown in Figure 3. To conserve power, no internal pullup resistor is incorporated on the hardware selectable address pin and it must be pulled HIGH or LOW.

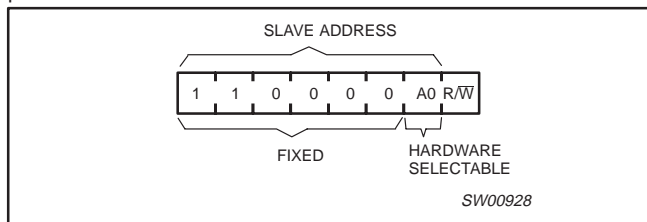

Figure 3. Slave address

The last bit of the address byte defines the operation to be performed. When set to logic 1 a read is selected while a logic 0 selects a write operation.

CONTROL REGISTER

Following the successful acknowledgement of the slave address, the bus master will send a byte to the PCA9530 which will be stored in the Control Register.

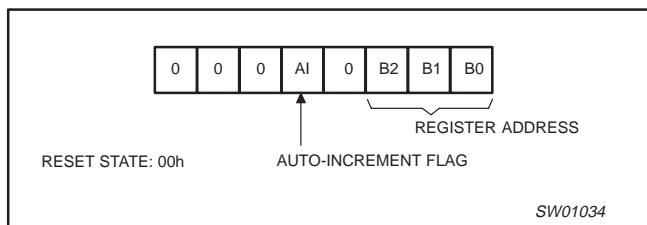

Figure 4. Control register

The lowest 3 bits are used as a pointer to determine which register will be accessed.

If the auto-increment flag is set, the three low order bits of the Control Register are automatically incremented after a read or write. This allows the user to program the registers sequentially. The contents of these bits will rollover to '000' after the last register is accessed.

When auto-increment flag is set (AI = 1) and a read sequence is initiated, the sequence must start by reading a register different from the input register (B2 B1 B0 ≠ 0 0 0).

Only the 3 least significant bits are affected by the AI flag.

Unused bits must be programmed with zeroes.

CONTROL REGISTER DEFINITION

B2	B1	B0	REGISTER NAME	TYPE	REGISTER FUNCTION
0	0	0	INPUT	READ	INPUT REGISTER
0	0	1	PSC0	READ/WRITE	FREQUENCY PRESCALER 0
0	1	0	PWM0	READ/WRITE	PWM REGISTER 0
0	1	1	PSC1	READ/WRITE	FREQUENCY PRESCALER 1
1	0	0	PWM1	READ/WRITE	PWM REGISTER 1
1	0	1	LS0	READ/WRITE	LED SELECTOR

REGISTER DESCRIPTION

INPUT — INPUT REGISTER

bit	7	6	5	4	3	2	1	0
default	0	0	0	0	0	0	X	X

The INPUT register reflects the state of the device pins. Writes to this register will be acknowledged but will have no effect.

NOTE: The default value "X" is determined by the externally applied logic level, normally '1' when used for directly driving LED with pull-up to V_{DD}.

PSC0 — FREQUENCY PRESCALER 0

bit	7	6	5	4	3	2	1	0
default	0	0	0	0	0	0	0	0

PSC0 is used to program the period of the PWM output.

$$\text{The period of BLINK0} = \frac{(PSC0 + 1)}{152}$$

PWM0 — PWM REGISTER 0

bit	7	6	5	4	3	2	1	0
default	1	0	0	0	0	0	0	0

The PWM0 register determines the duty cycle of BLINK0. The outputs are LOW (LED on) when the count is less than the value in PWM0 and HIGH (LED off) when it is greater. If PWM0 is programmed with 00h, then the PWM0 output is always HIGH (LED off).

$$\text{The duty cycle of BLINK0 is: } \frac{PWM0}{256}$$

PSC1 — FREQUENCY PRESCALER 1

bit	7	6	5	4	3	2	1	0
default	0	0	0	0	0	0	0	0

PSC1 is used to program the period of PWM output.

$$\text{The period of BLINK1} = \frac{(PSC1 + 1)}{152}$$

2-bit I²C LED dimmer

PCA9530

PWM1 — PWM REGISTER 1

bit	7	6	5	4	3	2	1	0
default	1	0	0	0	0	0	0	0

The PWM1 register determines the duty cycle of BLINK1. The outputs are LOW (LED on) when the count is less than the value in PWM1 and HIGH (LED off) when it is greater. If PWM1 is programmed with 00h, then the PWM1 output is always HIGH (LED off).

The duty cycle of BLINK1 is: $\frac{PWM1}{256}$

LS0 — LED SELECTOR

					LED 1		LED 0	
bit	7	6	5	4	3	2	1	0
default	1	1	1	1	0	0	0	0

The LSx LED select registers determine the source of the LED data.

- 00 = Output is set Hi-Z (LED off – default)
- 01 = Output is set LOW (LED on)
- 10 = Output blinks at PWM0 rate
- 11 = Output blinks at PWM1 rate

PINS USED AS GENERAL PURPOSE I/Os

LED pins not used to control LEDs can be used as general purpose I/Os.

For use as input: Set LEDx to high-impedance (00) and then read the pin state via the input register.

For use as output: Connect external pull-up resistor to the pin and size it according to the DC recommended operating characteristics. LED output pin is HIGH when the output is programmed as high-impedance, and LOW when the output is programmed LOW through the “LED selector” register. The output can be pulse-width controlled when PWM0 or PWM1 are used.

POWER-ON RESET

When power is applied to V_{DD}, an internal Power-On Reset holds the PCA9530 in a reset condition until V_{DD} has reached V_{POR}. At this point, the reset condition is released and the PCA9530 registers are initialized to their default states, all the outputs in the off state. Thereafter, V_{DD} must be lowered below 0.2 V to reset the device.

EXTERNAL RESET

A reset can be accomplished by holding the \overline{RESET} pin LOW for a minimum of t_W. The PCA9530 registers and I²C state machine will be held in their default state until the \overline{RESET} input is once again HIGH.

This input requires a pull-up resistor to V_{DD} if no active connection is used.

CHARACTERISTICS OF THE I²C-BUS

The I²C-bus is for 2-way, 2-line communication between different ICs or modules. The two lines are a serial data line (SDA) and a serial clock line (SCL). Both lines must be connected to a positive supply via a pull-up resistor when connected to the output stages of a device. Data transfer may be initiated only when the bus is not busy.

Bit transfer

One data bit is transferred during each clock pulse. The data on the SDA line must remain stable during the HIGH period of the clock pulse as changes in the data line at this time will be interpreted as control signals (see Figure 5).

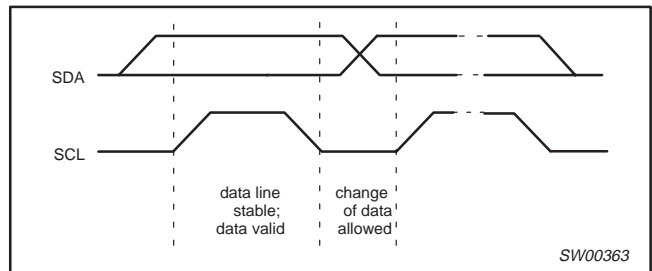

Figure 5. Bit transfer

Start and stop conditions

Both data and clock lines remain HIGH when the bus is not busy. A HIGH-to-LOW transition of the data line, while the clock is HIGH is defined as the start condition (S). A LOW-to-HIGH transition of the data line while the clock is HIGH is defined as the stop condition (P) (see Figure 6).

System configuration

A device generating a message is a transmitter; a device receiving is the receiver. The device that controls the message is the master and the devices which are controlled by the master are the slaves (see Figure 7).

2-bit I²C LED dimmer

PCA9530

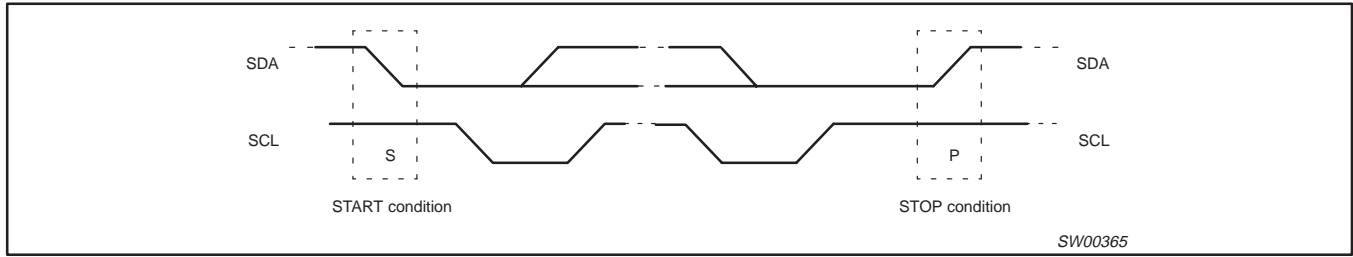

Figure 6. Definition of start and stop conditions

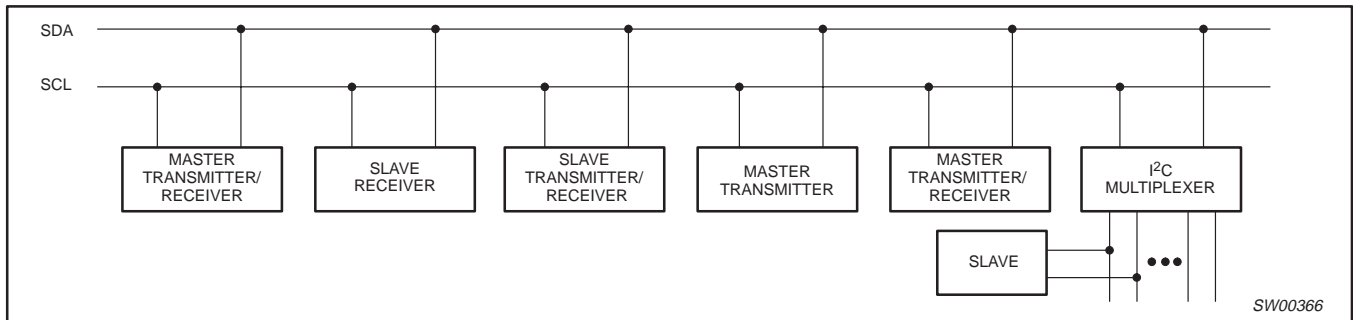

Figure 7. System configuration

Acknowledge

The number of data bytes transferred between the start and the stop conditions from transmitter to receiver is not limited. Each byte of eight bits is followed by one acknowledge bit. The acknowledge bit is a HIGH level put on the bus by the transmitter whereas the master generates an extra acknowledge related clock pulse.

A slave receiver which is addressed must generate an acknowledge after the reception of each byte. Also a master must generate an acknowledge after the reception of each byte that has been clocked out of the slave transmitter. The device that acknowledges has to pull down the SDA line during the acknowledge clock pulse, so that the SDA line is stable LOW during the HIGH period of the acknowledge related clock pulse, set-up and hold times must be taken into account.

A master receiver must signal an end of data to the transmitter by not generating an acknowledge on the last byte that has been clocked out of the slave. In this event, the transmitter must leave the data line HIGH to enable the master to generate a stop condition.

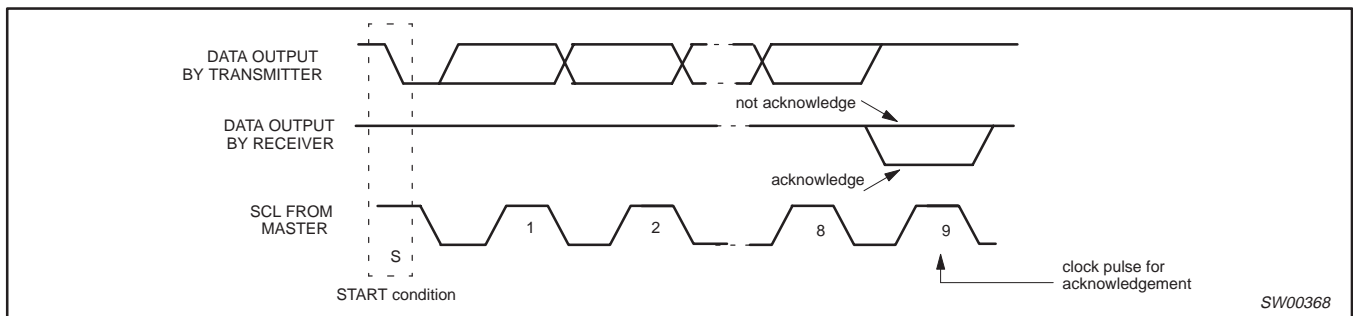
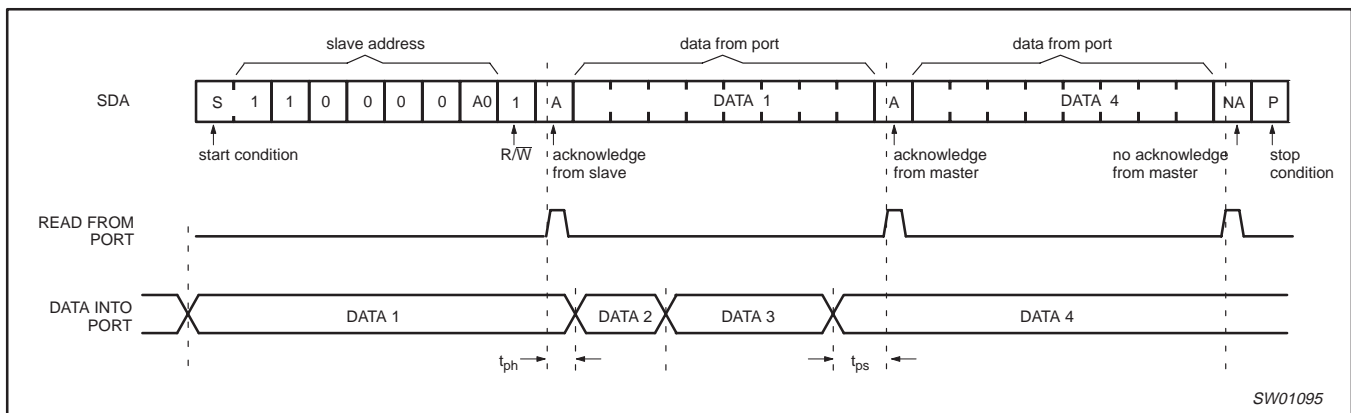
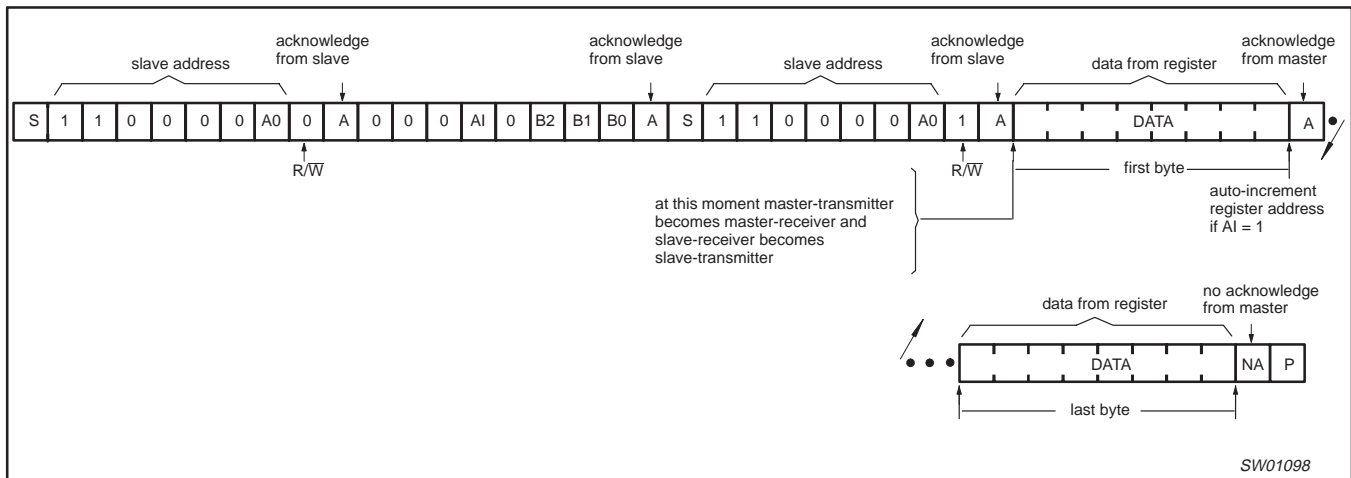
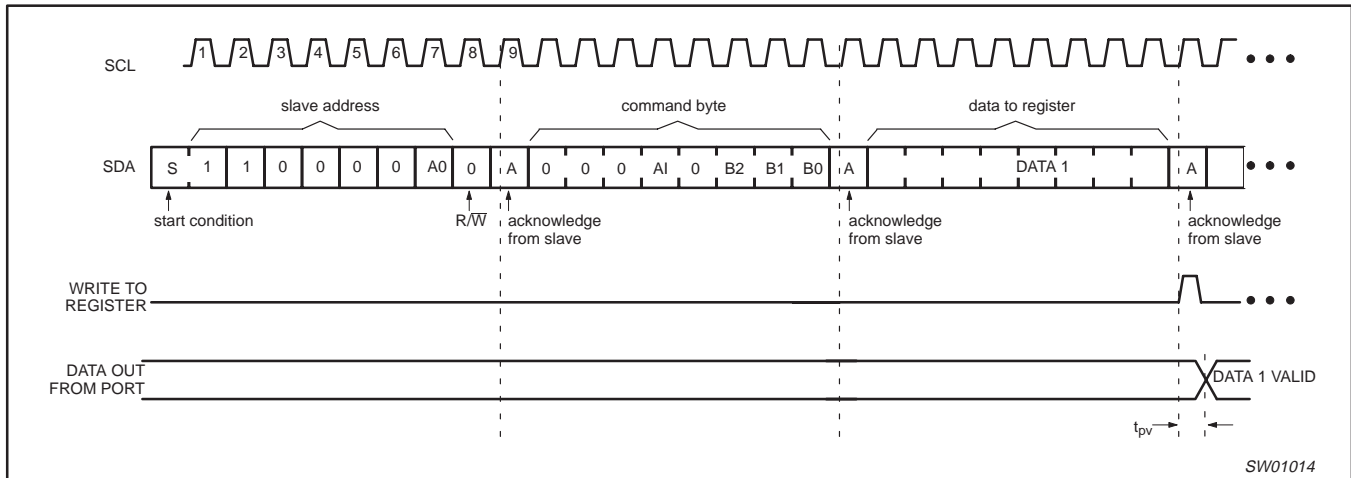

Figure 8. Acknowledgement on the I²C-bus

2-bit I²C LED dimmer

PCA9530

Bus transactions



NOTES:

1. This figure assumes the command byte has previously been programmed with 00h.

Figure 11. READ input port register

2-bit I²C LED dimmer

PCA9530

APPLICATION DATA

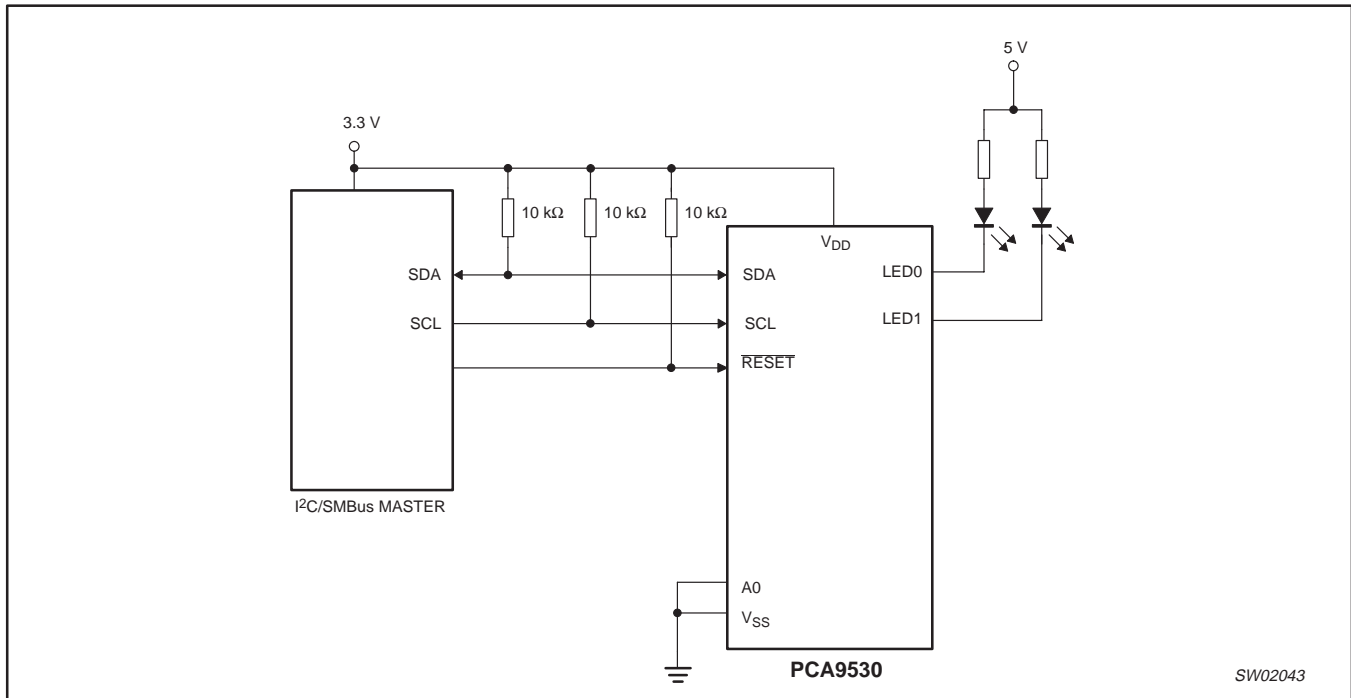

Figure 12. Typical application

Minimizing I_{DD} when the I/O is used to control LEDs

When the I/Os are used to control LEDs, they are normally connected to V_{DD} through a resistor as shown in Figure 12. Since the LED acts as a diode, when the LED is off the I/O V_{IN} is about 1.2 V less than V_{DD}. The supply current, I_{DD}, increases as V_{IN} becomes lower than V_{DD} and is specified as ΔI_{DD} in the DC characteristics table.

Designs needing to minimize current consumption, such as battery power applications, should consider maintaining the I/O pins greater than or equal to V_{DD} when the LED is off. Figure 13 shows a high value resistor in parallel with the LED. Figure 14 shows V_{DD} less than the LED supply voltage by at least 1.2 V. Both of these methods maintain the I/O V_{IN} at or above V_{DD} and prevents additional supply current consumption when the LED is off.

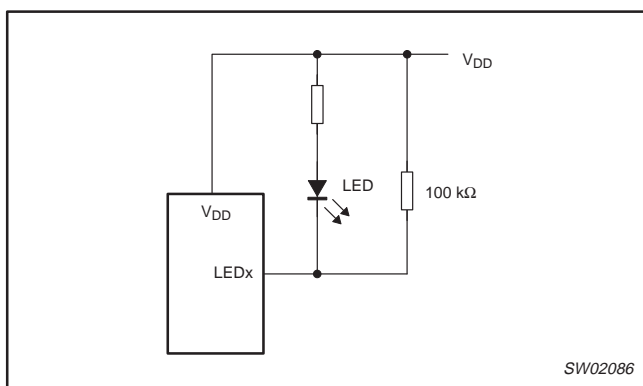

Figure 13. High value resistor in parallel with the LED

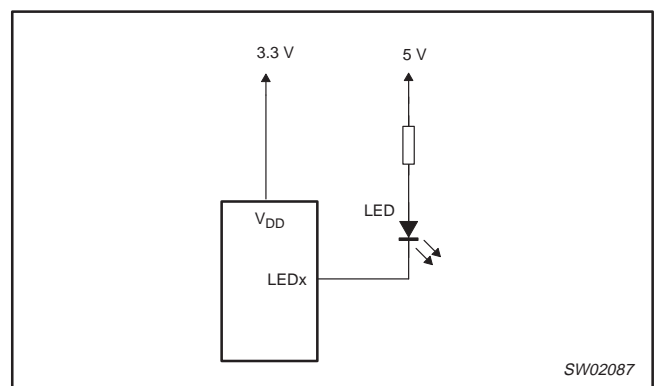

Figure 14. Device supplied by a lower voltage

2-bit I²C LED dimmer

PCA9530

Programming example

The following example will show how to set LED0 to blink at 1 Hz at a 50 % duty cycle. LED1 will be set to be dimmed at 25 % of their maximum brightness (duty cycle = 25 %).

Table 1.

	I ² C-bus
Start	S
PCA9530 address with A0 = LOW	COh
PSC0 subaddress + auto-increment	11h
Set prescaler PSC0 to achieve a period of 1 second: $\text{Blink period} = 1 = \frac{\text{PSC0} + 1}{152}$ PSC0 = 151	97h
Set PWM0 duty cycle to 50 %: $\frac{\text{PWM0}}{256} = 0.5$ PWM0 = 128	80h
Set prescaler PCS1 to dim at maximum frequency. Blink period = maximum. PSC1 = 0	00h
Set PWM1 output duty cycle to 25 %: $\frac{\text{PWM1}}{256} = 0.25$ PWM1 = 64	40h
Set LED0 to PWM0 and set LED1 to blink at PWM1	OEh
Stop	P

2-bit I²C LED dimmer

PCA9530

ABSOLUTE MAXIMUM RATINGS

In accordance with the Absolute Maximum Rating System (IEC 134)

SYMBOL	PARAMETER	CONDITIONS	MIN	MAX	UNIT
V _{DD}	Supply voltage		-0.5	6.0	V
V _{I/O}	DC voltage on an I/O		V _{SS} - 0.5	5.5	V
I _{I/O}	DC output current on an I/O		—	+25	mA
I _{SS}	Supply current		—	50	mA
P _{tot}	Total power dissipation		—	400	mW
T _{stg}	Storage temperature range		-65	+150	°C
T _{amb}	Operating ambient temperature		-40	+85	°C

HANDLING

Inputs and outputs are protected against electrostatic discharge in normal handling. However, to be totally safe, it is desirable to take precautions appropriate to handling MOS devices. Advice can be found in Data Handbook IC24 under "Handling MOS devices".

DC CHARACTERISTICSV_{DD} = 2.3 V to 5.5 V; V_{SS} = 0 V; T_{amb} = -40 °C to +85 °C; unless otherwise specified. TYP at 3.3 V and 25 °C.

SYMBOL	PARAMETER	CONDITIONS	MIN	TYP	MAX	UNIT
Supplies						
V _{DD}	Supply voltage		2.3	—	5.5	V
I _{DD}	Supply current	Operating mode; V _{DD} = 5.5 V; no load; V _I = V _{DD} or V _{SS} ; f _{SCL} = 100 kHz	—	350	500	μA
I _{stb}	Standby current	Standby mode; V _{DD} = 5.5 V; no load; V _I = V _{DD} or V _{SS} ; f _{SCL} = 0 kHz	—	1.9	3.0	μA
ΔI _{DD}	Additional standby current	Standby mode; V _{DD} = 5.5 V; Every LED I/O at V _{IN} = 4.3 V; f _{SCL} = 0 kHz	—	—	200	μA
V _{POR}	Power-on reset voltage (Note 1)	No load; V _I = V _{DD} or V _{SS}	—	1.7	2.2	V
Input SCL; input/output SDA						
V _{IL}	LOW-level input voltage		-0.5	—	0.3V _{DD}	V
V _{IH}	HIGH-level input voltage		0.7V _{DD}	—	5.5	V
I _{OL}	LOW-level output current	V _{OL} = 0.4 V	3	6.5	—	mA
I _L	Leakage current	V _I = V _{DD} = V _{SS}	-1	—	+1	μA
C _I	Input capacitance	V _I = V _{SS}	—	3.7	5	pF
I/Os						
V _{IL}	LOW-level input voltage		-0.5	—	0.8	V
V _{IH}	HIGH-level input voltage		2.0	—	5.5	V
I _{OL}	LOW-level output current	V _{OL} = 0.4 V; V _{DD} = 2.3 V; Note 2	9	—	—	mA
		V _{OL} = 0.4 V; V _{DD} = 3.0 V; Note 2	12	—	—	mA
		V _{OL} = 0.4 V; V _{DD} = 5.0 V; Note 2	15	—	—	mA
		V _{OL} = 0.7 V; V _{DD} = 2.3 V; Note 2	15	—	—	mA
		V _{OL} = 0.7 V; V _{DD} = 3.0 V; Note 2	20	—	—	mA
		V _{OL} = 0.7 V; V _{DD} = 5.0 V; Note 2	25	—	—	mA
I _L	Input leakage current	V _{DD} = 3.6 V; V _I = 0 V or V _{DD}	-1	—	1	μA
C _{IO}	Input/output capacitance		—	2.1	5	pF
Select Inputs A0 / RESET						
V _{IL}	LOW-level input voltage		-0.5	—	0.8	V
V _{IH}	HIGH-level input voltage		2.0	—	5.5	V
I _{LI}	Input leakage current		-1	—	1	μA
C _I	Input capacitance	V _I = V _{SS}	—	2.3	5	pF

NOTE:

- V_{DD} must be lowered to 0.2 V in order to reset part.
- Each I/O must be externally limited to a maximum of 25 mA and the device must be limited to a maximum current of 50 mA.

2-bit I²C LED dimmer

PCA9530

AC SPECIFICATIONS

SYMBOL	PARAMETER	STANDARD MODE I ² C-BUS		FAST MODE I ² C-BUS		UNITS
		MIN	MAX	MIN	MAX	
f _{SCL}	Operating frequency	0	100	0	400	kHz
t _{BUF}	Bus free time between STOP and START conditions	4.7	—	1.3	—	μs
t _{HD;STA}	Hold time after (repeated) START condition	4.0	—	0.6	—	μs
t _{SU;STA}	Repeated START condition setup time	4.7	—	0.6	—	μs
t _{SU;STO}	Setup time for STOP condition	4.0	—	0.6	—	μs
t _{HD;DAT}	Data in hold time	0	—	0	—	ns
t _{VD;ACK}	Valid time for ACK condition ²	—	600	—	600	ns
t _{VD;DAT (L)}	Data out valid time ³	—	600	—	600	ns
t _{VD;DAT (H)}	Data out valid time ³	—	1500	—	600	ns
t _{SU;DAT}	Data setup time	250	—	100	—	ns
t _{LOW}	Clock LOW period	4.7	—	1.3	—	μs
t _{HIGH}	Clock HIGH period	4.0	—	0.6	—	μs
t _F	Clock/Data fall time	—	300	20 + 0.1 C _b ¹	300	ns
t _R	Clock/Data rise time	—	1000	20 + 0.1 C _b ¹	300	ns
t _{SP}	Pulse width of spikes that must be suppressed by the input filters	—	50	—	50	ns
Port Timing						
t _{PV}	Output data valid	—	200	—	200	ns
t _{PS}	Input data setup time	100	—	100	—	ns
t _{PH}	Input data hold time	1	—	1	—	μs
Reset						
t _W	Reset pulse width	6	—	6	—	ns
t _{REC}	Reset recovery time	0	—	0	—	ns
t _{RESET} ^{4,5}	Time to reset	400	—	400	—	ns

NOTES:

1. C_b = total capacitance of one bus line in pF.
2. t_{VD;ACK} = time for Acknowledgement signal from SCL LOW to SDA (out) LOW.
3. t_{VD;DAT} = minimum time for SDA data out to be valid following SCL LOW.
4. Resetting the device while actively communicating on the bus may cause glitches or errant STOP conditions.
5. Upon reset, the full delay will be the sum of t_{RESET} and the RC time constant of the SDA bus.

2-bit I²C LED dimmer

PCA9530

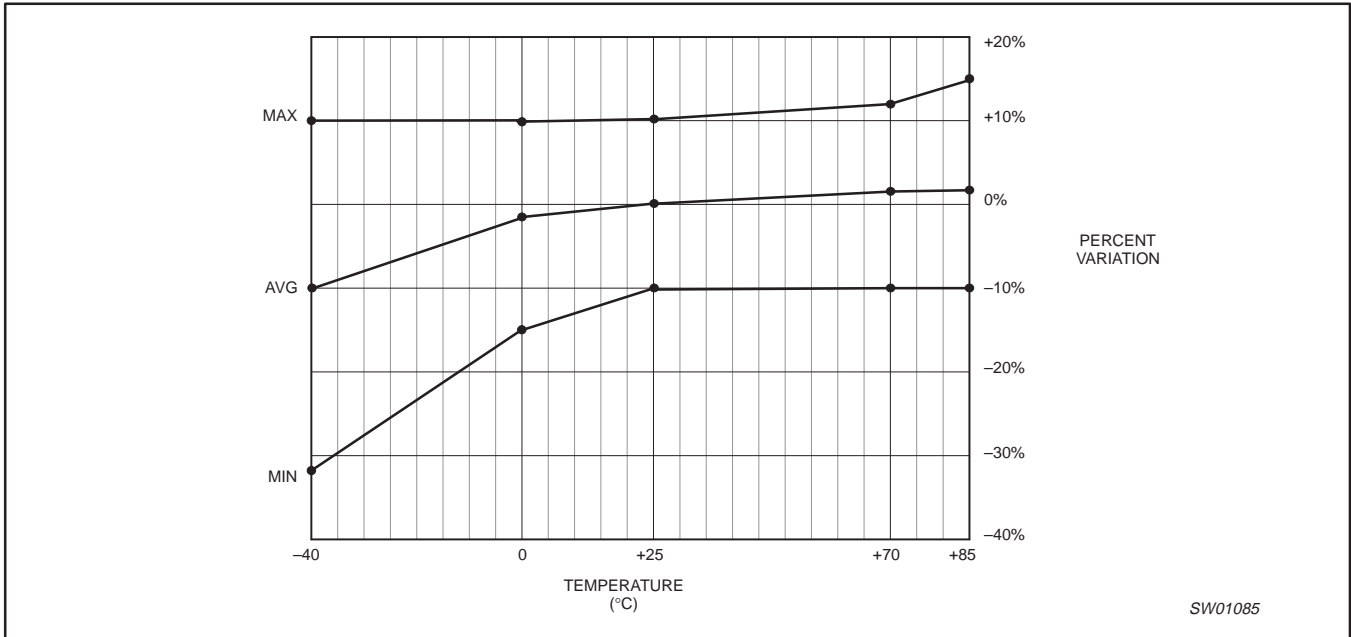

Figure 15. Typical frequency variation over process at V_{DD} = 2.3 V to 3.0 V

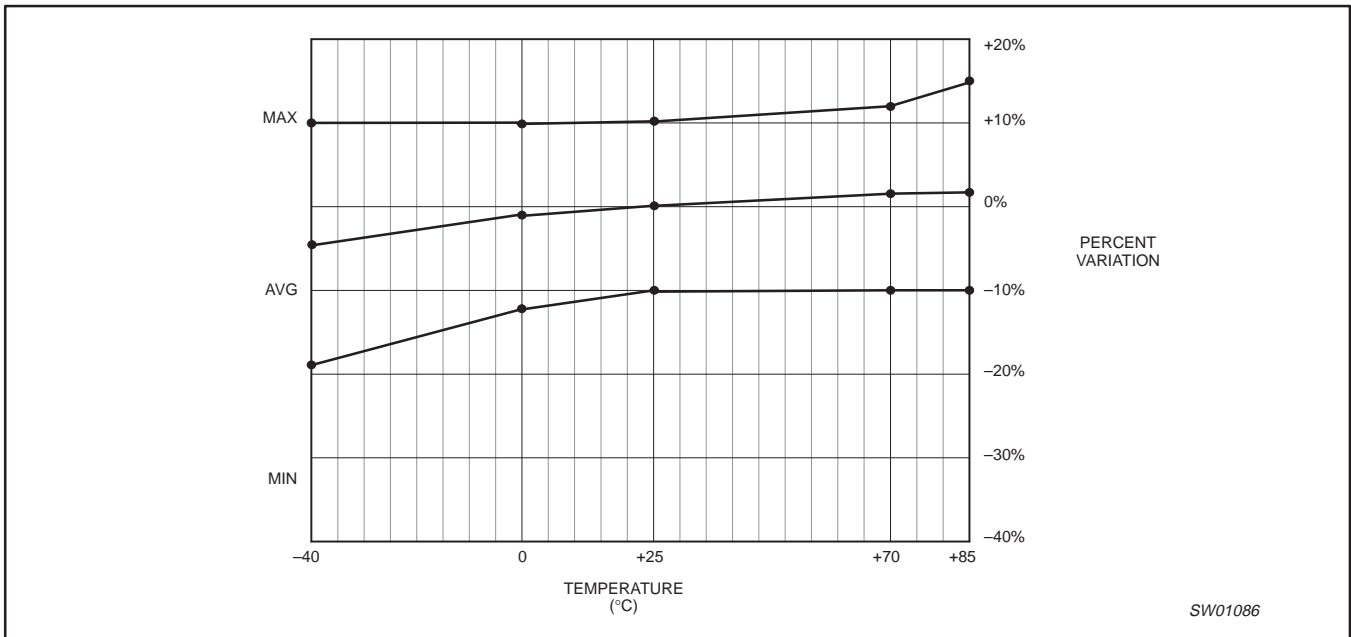

Figure 16. Typical frequency variation over process at V_{DD} = 3.0 V to 5.5 V

2-bit I²C LED dimmer

PCA9530

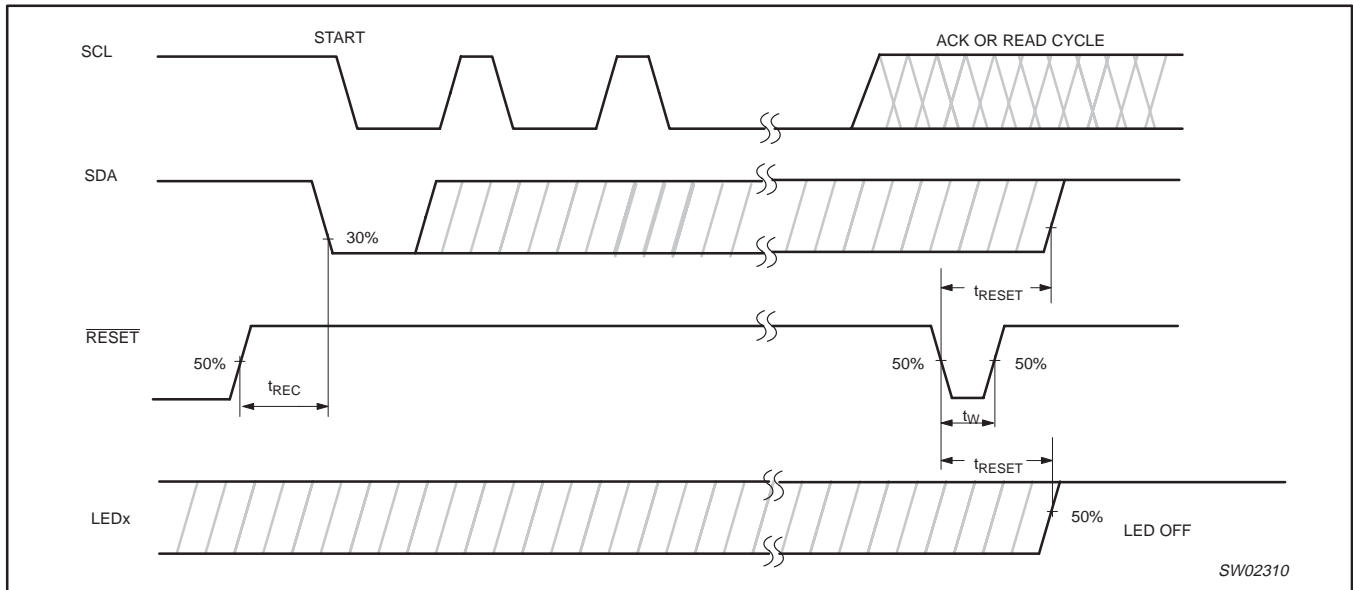

Figure 17. Definition of RESET timing

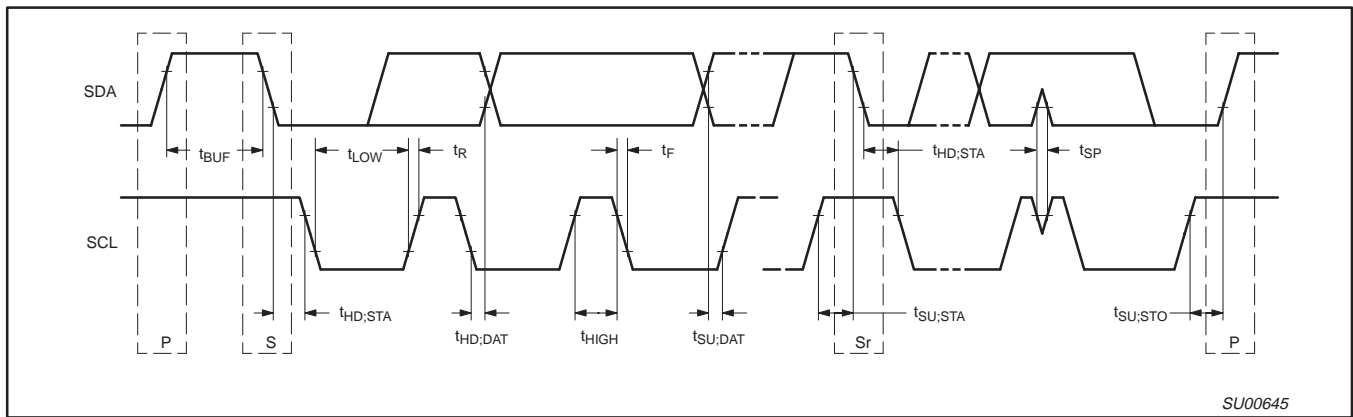

Figure 18. Definition of timing

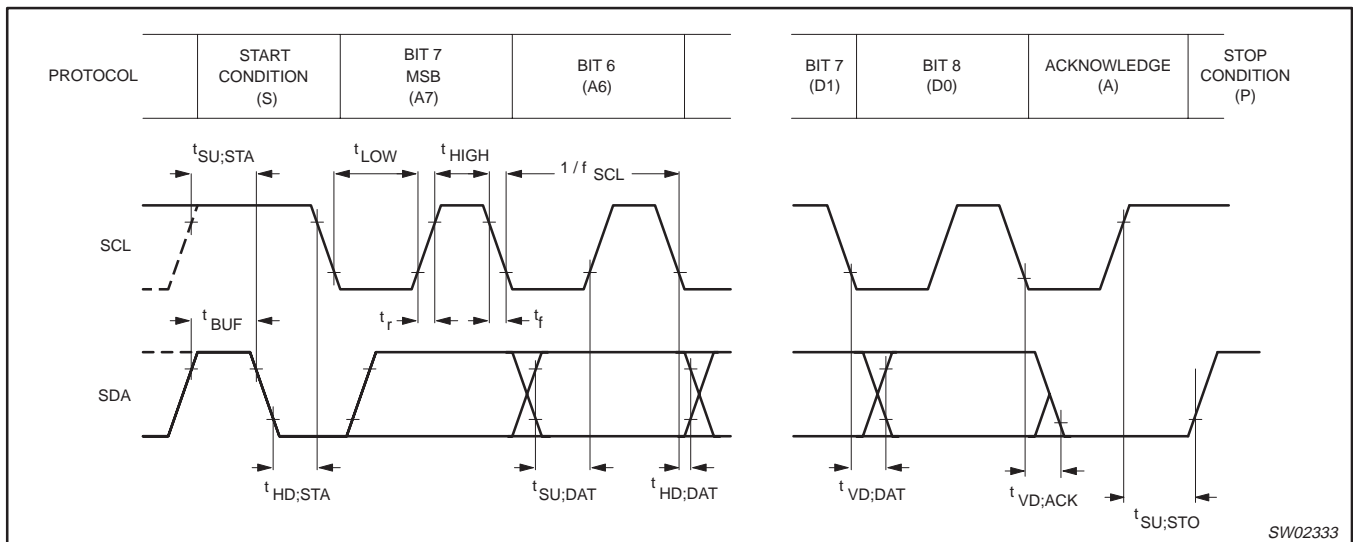
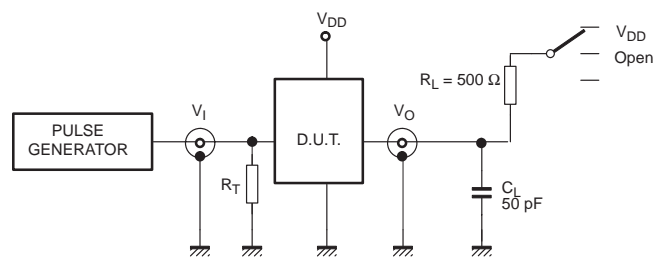

Figure 19. I²C-bus timing diagram; rise and fall times refer to V_{IL} and V_{IH}

2-bit I²C LED dimmer

PCA9530

**DEFINITIONS**

R_L = Load resistor FOR LEDN. R_L FOR SDA AND SCL > 1 k Ω
(3 mA or less current).

C_L = Load capacitance includes jig and probe capacitance

R_T = Termination resistance should be equal to the output
impedance Z_O of the pulse generators.

SW02334

Figure 20. Test circuitry for switching times

2-bit I²C LED dimmer

PCA9530

S08: plastic small outline package; 8 leads; body width 3.9 mm

SOT96-1

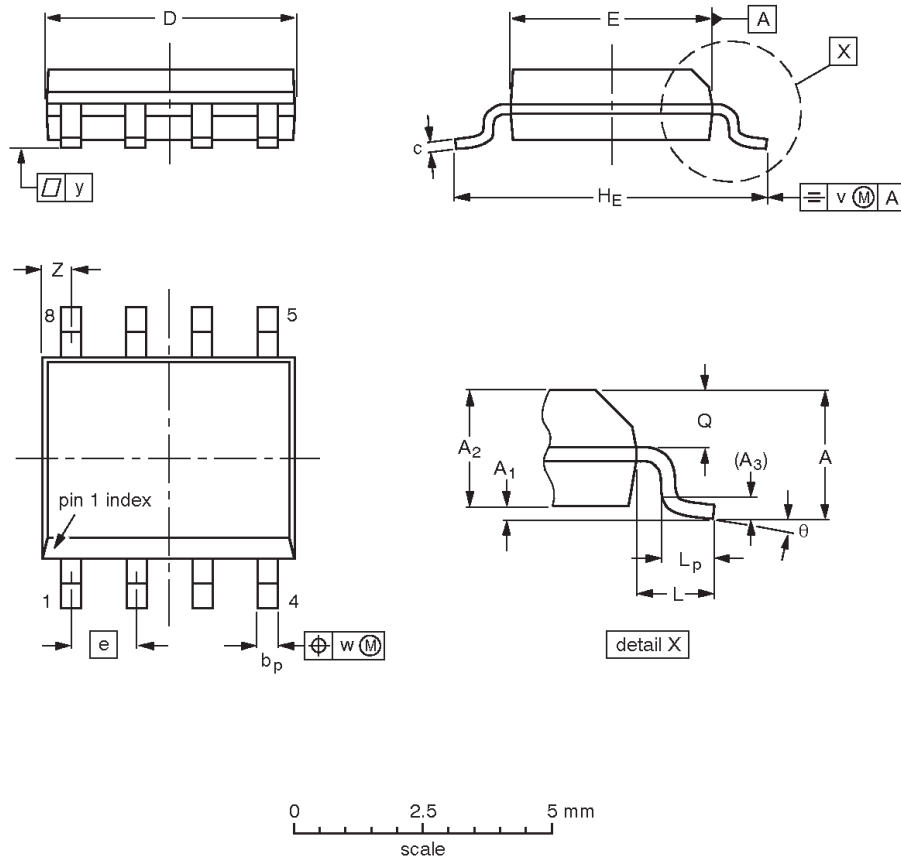

DIMENSIONS (inch dimensions are derived from the original mm dimensions)

UNIT	A _{max.}	A ₁	A ₂	A ₃	b _p	c	D ⁽¹⁾	E ⁽²⁾	e	H _E	L	L _p	Q	v	w	y	Z ⁽¹⁾	θ
mm	1.75	0.25 0.10	1.45 1.25	0.25	0.49 0.36	0.25 0.19	5.0 4.8	4.0 3.8	1.27	6.2 5.8	1.05	1.0 0.4	0.7 0.6	0.25	0.25	0.1	0.7 0.3	8° 0°
inches	0.069	0.010 0.004	0.057 0.049	0.01	0.019 0.014	0.0100 0.0075	0.20 0.19	0.16 0.15	0.05	0.244 0.228	0.041	0.039 0.016	0.028 0.024	0.01	0.01	0.004	0.028 0.012	

Notes

1. Plastic or metal protrusions of 0.15 mm (0.006 inch) maximum per side are not included.
2. Plastic or metal protrusions of 0.25 mm (0.01 inch) maximum per side are not included.

OUTLINE VERSION	REFERENCES				EUROPEAN PROJECTION	ISSUE DATE
	IEC	JEDEC	JEITA			
SOT96-1	076E03	MS-012				99-12-27 03-02-18

2-bit I²C LED dimmer

PCA9530

TSSOP8: plastic thin shrink small outline package; 8 leads; body width 3 mm

SOT505-1

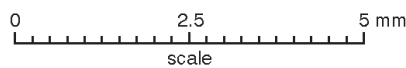
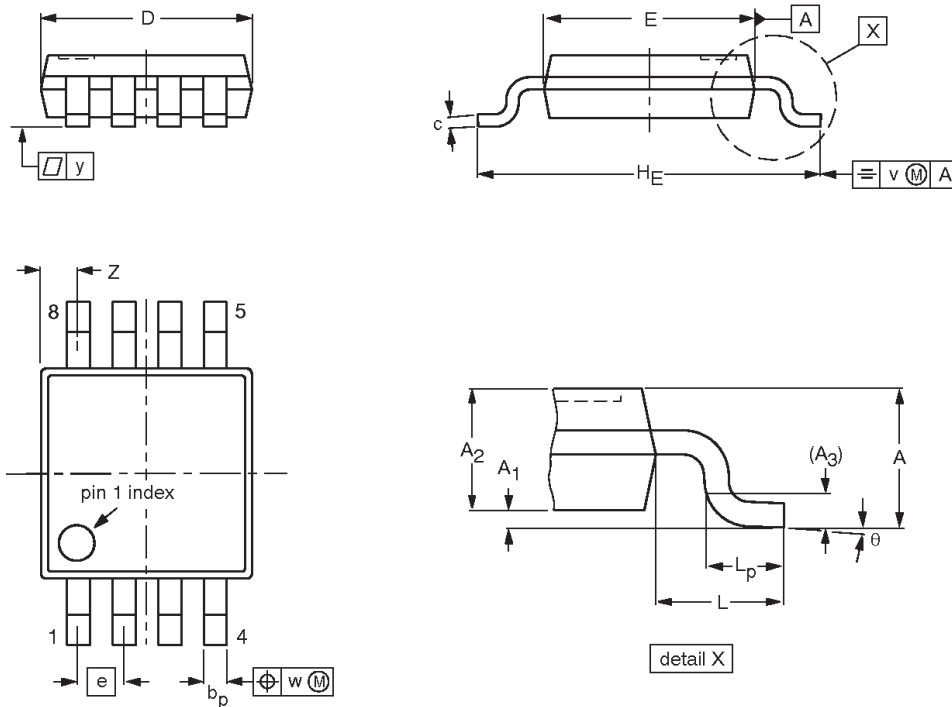

DIMENSIONS (mm are the original dimensions)

UNIT	A max.	A ₁	A ₂	A ₃	b _p	c	D ⁽¹⁾	E ⁽²⁾	e	H _E	L	L _p	v	w	y	Z ⁽¹⁾	θ
mm	1.1	0.15 0.05	0.95 0.80	0.25	0.45 0.25	0.28 0.15	3.1 2.9	3.1 2.9	0.65	5.1 4.7	0.94	0.7 0.4	0.1	0.1	0.1	0.70 0.35	6° 0°

Notes

1. Plastic or metal protrusions of 0.15 mm maximum per side are not included.
2. Plastic or metal protrusions of 0.25 mm maximum per side are not included.

OUTLINE VERSION	REFERENCES				EUROPEAN PROJECTION	ISSUE DATE
	IEC	JEDEC	JEITA			
SOT505-1						99-04-09 03-02-18

2-bit I²C LED dimmer

PCA9530

REVISION HISTORY

Rev	Date	Description
2	20041001	<p>Product data sheet (9397 750 14093). Supersedes data of 2004 Sep 14 (9397 750 13631).</p> <p>Modifications:</p> <ul style="list-style-type: none"> ● “Features” section on page 2: <ul style="list-style-type: none"> – second bullet: change from “... between 0.625 and 160 Hz (1.6 seconds and 6.25 milliseconds)” to “... between 0.591 Hz and 152 Hz (1.69 seconds and 6.58 milliseconds)” – last bullet: add “(MSOP8)” ● “Description” section on page 2: <ul style="list-style-type: none"> – Third paragraph, third sentence: change from “... or blink at periods up to 1.6 second.” to “... or blink at periods up to 1.69 second.” – Fourth paragraph, first sentence: change from “... periods greater than 1.6 second ...” to “... periods greater than 1.69 second.” ● Ordering information table on page 2: add “(MSOP)” to table cell ‘8-Pin Plastic TSSOP’ ● Add note to section “Input—Input Register” on page 4 ● Add section “Pins used as General Purpose I/Os” on page 5. ● Figure 12 on page 8: add resistor values ● DC characteristics table on page 10: add ΔI{DD} Max value (200 μA). ● AC specifications table on page 11: change $t_{VD,ACK}$ Max value (for both modes) from 900 ns to 600 ns.
_1	20040914	Product data sheet (9397 750 13631).

2-bit I²C LED dimmer

PCA9530



Purchase of Philips I²C components conveys a license under the Philips' I²C patent to use the components in the I²C system provided the system conforms to the I²C specifications defined by Philips. This specification can be ordered using the code 9398 393 40011.

Data sheet status

Level	Data sheet status ^[1]	Product status ^[2] [3]	Definitions
I	Objective data sheet	Development	This data sheet contains data from the objective specification for product development. Philips Semiconductors reserves the right to change the specification in any manner without notice.
II	Preliminary data sheet	Qualification	This data sheet contains data from the preliminary specification. Supplementary data will be published at a later date. Philips Semiconductors reserves the right to change the specification without notice, in order to improve the design and supply the best possible product.
III	Product data sheet	Production	This data sheet contains data from the product specification. Philips Semiconductors reserves the right to make changes at any time in order to improve the design, manufacturing and supply. Relevant changes will be communicated via a Customer Product/Process Change Notification (CPCN).

[1] Please consult the most recently issued data sheet before initiating or completing a design.

[2] The product status of the device(s) described in this data sheet may have changed since this data sheet was published. The latest information is available on the Internet at URL <http://www.semiconductors.philips.com>.

[3] For data sheets describing multiple type numbers, the highest-level product status determines the data sheet status.

Definitions

Short-form specification — The data in a short-form specification is extracted from a full data sheet with the same type number and title. For detailed information see the relevant data sheet or data handbook.

Limiting values definition — Limiting values given are in accordance with the Absolute Maximum Rating System (IEC 60134). Stress above one or more of the limiting values may cause permanent damage to the device. These are stress ratings only and operation of the device at these or at any other conditions above those given in the Characteristics sections of the specification is not implied. Exposure to limiting values for extended periods may affect device reliability.

Application information — Applications that are described herein for any of these products are for illustrative purposes only. Philips Semiconductors make no representation or warranty that such applications will be suitable for the specified use without further testing or modification.

Disclaimers

Life support — These products are not designed for use in life support appliances, devices, or systems where malfunction of these products can reasonably be expected to result in personal injury. Philips Semiconductors customers using or selling these products for use in such applications do so at their own risk and agree to fully indemnify Philips Semiconductors for any damages resulting from such application.

Right to make changes — Philips Semiconductors reserves the right to make changes in the products—including circuits, standard cells, and/or software—described or contained herein in order to improve design and/or performance. When the product is in full production (status 'Production'), relevant changes will be communicated via a Customer Product/Process Change Notification (CPCN). Philips Semiconductors assumes no responsibility or liability for the use of any of these products, conveys no license or title under any patent, copyright, or mask work right to these products, and makes no representations or warranties that these products are free from patent, copyright, or mask work right infringement, unless otherwise specified.

Contact information

For additional information please visit
<http://www.semiconductors.philips.com>. Fax: +31 40 27 24825

© Koninklijke Philips Electronics N.V. 2004
 All rights reserved. Published in the U.S.A.

Date of release: 10-04

For sales offices addresses send e-mail to:
sales.addresses@www.semiconductors.philips.com

Document number:

9397 750 14093

Let's make things better.