



MICROWAVE CORPORATION v02.0505



# HMC207S8 / 207S8E

## GaAs MMIC SMT DOUBLE-BALANCED MIXER, 0.7 - 2.0 GHz

### Typical Applications

The HMC207S8 / HMC207S8E is ideal for:

- Base Stations
- Cable Modems
- Portable Wireless

### Features

- Conversion Loss: 9.0 dB
- LO / IF Isolation: 45 dB
- LO / RF Isolation: 40 dB
- IP3 (Input): +17 dBm

### Functional Diagram

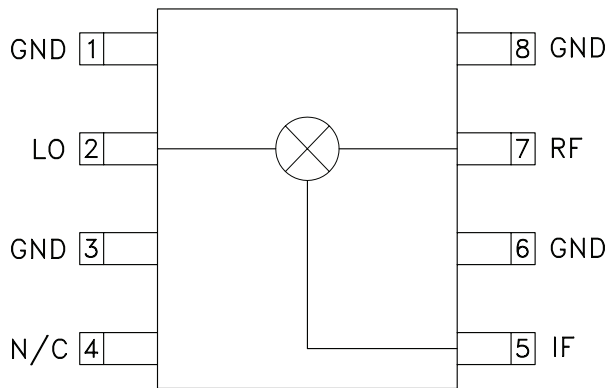

### General Description

The HMC207S8 & HMC207S8E are miniature double-balanced mixers in 8 lead plastic surface mount Small Outline IC (SOIC) packages. This passive MMIC mixer is constructed of GaAs Schottky diodes and novel planar transformer baluns on the chip. The device can be used as an upconverter, downconverter, biphas modulator (de)modulator, or phase comparator. The consistent MMIC performance will improve system operation and assure regulatory compliance. The high LO suppression of 45 to 50 dB yields excellent carrier suppression for modulator applications.

### Electrical Specifications, $T_A = +25^\circ C$ , As a Function of LO Drive

Parameter	LO = +13 dBm IF = 70 MHz			LO = +10 dBm IF = 70 MHz			Units
	Min.	Typ.	Max.	Min.	Typ.	Max.	
Frequency Range, RF & LO	0.7 - 2.0			0.8 - 1.2			GHz
Frequency Range, IF	DC - 0.3			DC - 0.3			GHz
Conversion Loss		9	10.5		7.5	10	dB
Noise Figure (SSB)		9	10.5		7.5	10	dB
LO to RF Isolation	32	40		40	45		dB
LO to IF Isolation	38	45		40	45		dB
RF to IF Isolation	17	23		18	22		dB
IP3 (Input)	14	17		12	15		dBm
1 dB Gain Compression (Input)	8	11		7	10		dBm



MICROWAVE CORPORATION v02.0505



# HMC207S8 / 207S8E

## GaAs MMIC SMT DOUBLE-BALANCED MIXER, 0.7 - 2.0 GHz

**Conversion Loss vs Temperature @ LO = +13 dBm**

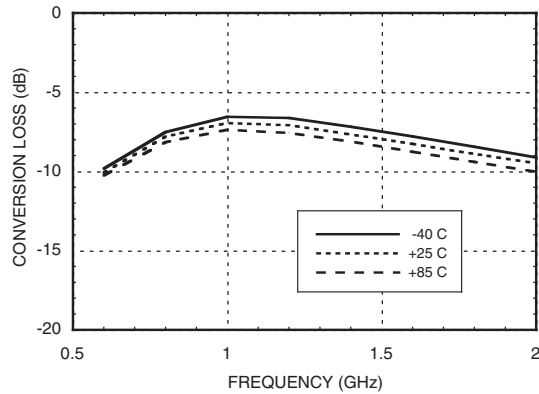

**Isolation @ LO = +13 dBm**

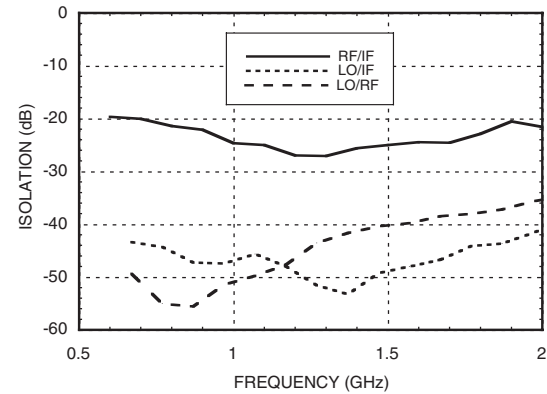

**Conversion Loss vs. LO Drive**

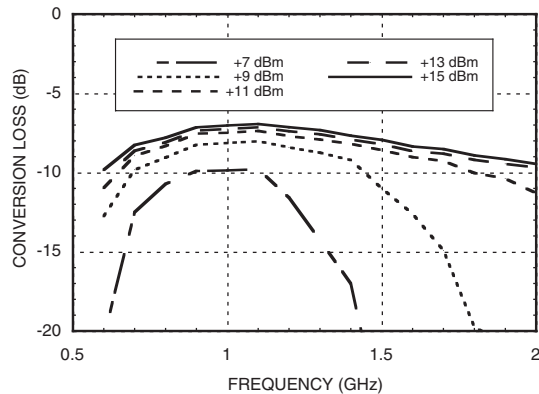

**Return Loss @ LO = +13 dBm**

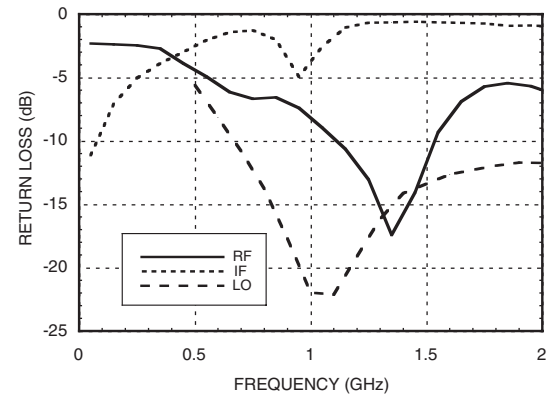

**IF Bandwidth @ LO = +13 dBm**

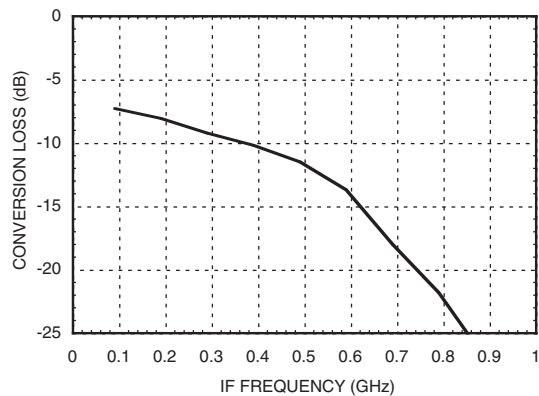

**P1dB vs. Temperature @ LO = +13 dBm**

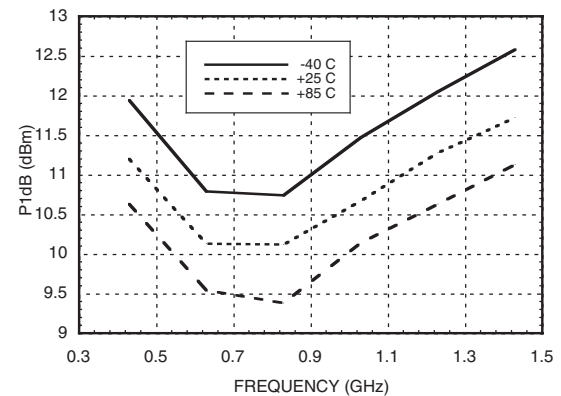



v02.0505



# HMC207S8 / 207S8E

## GaAs MMIC SMT DOUBLE-BALANCED MIXER, 0.7 - 2.0 GHz

**Input IP3 vs. LO Drive**

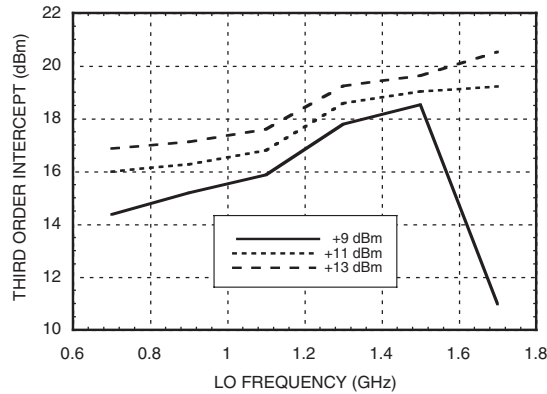

**Input IP3 vs. Temperature @ LO = +13 dBm**

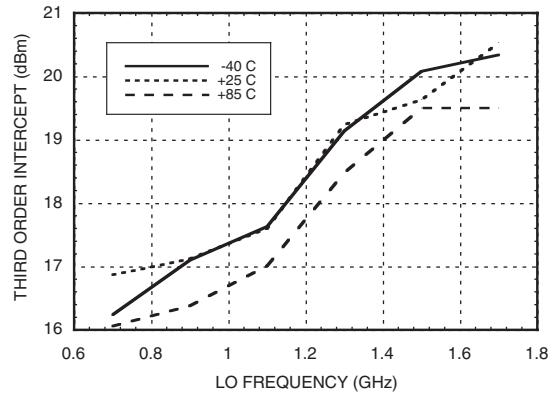

**Input IP2 vs. LO Drive**

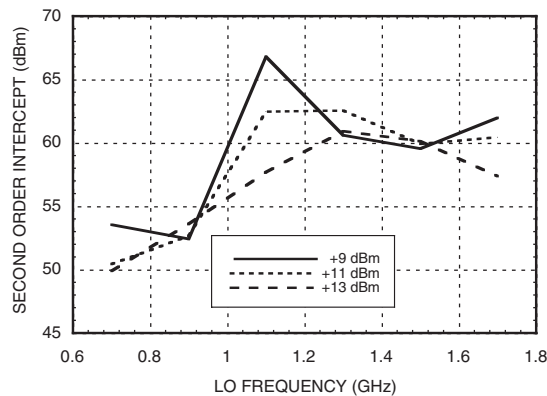

**Input IP2 vs. Temperature @ LO = +13 dBm**

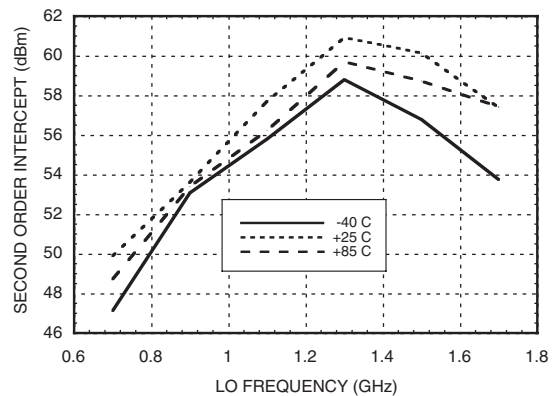

**MxN Spurious Outputs**

mRF	nLO				
	0	1	2	3	4
0	xx	19	27	20	36
1	17	0	43	43	39
2	64	66	63	74	75
3	91	94	92	65	86
4	>105	>105	>105	97	97

RF = 0.9 GHz @ -10 dBm  
 LO = 0.97 GHz @ +13 dBm  
 All values in dBc relative to the IF

**Harmonics of LO**

LO Freq. (GHz)	nLO Spur at RF Port			
	1	2	3	4
0.7	49	38	54	50
0.9	54	35	53	59
1.1	49	34	53	57
1.3	42	34	46	56
1.5	40	36	43	58
1.7	38	42	40	61

LO = +13 dBm  
 Values in dBc below input LO level measured at RF Port.



MICROWAVE CORPORATION v02.0505



# HMC207S8 / 207S8E

## GaAs MMIC SMT DOUBLE-BALANCED MIXER, 0.7 - 2.0 GHz

### Absolute Maximum Ratings

RF / IF Input	+13 dBm
LO Drive	+27 dBm
Storage Temperature	-65 to +150 °C
Operating Temperature	-40 to +85 °C



ELECTROSTATIC SENSITIVE DEVICE  
OBSERVE HANDLING PRECAUTIONS

### Outline Drawing

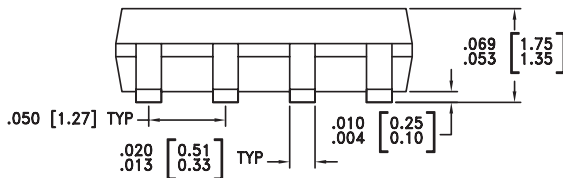
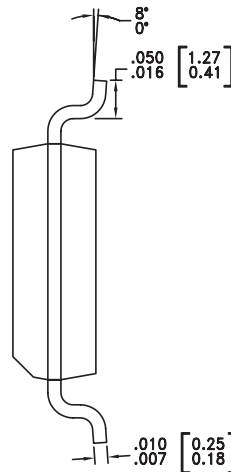
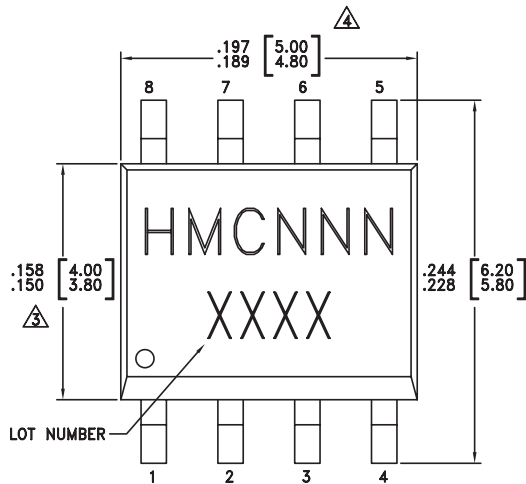

NOTES:

1. LEADFRAME MATERIAL: COPPER ALLOY
2. DIMENSIONS ARE IN INCHES [MILLIMETERS].
3. DIMENSION DOES NOT INCLUDE MOLDFLASH OF 0.15mm PER SIDE.
4. DIMENSION DOES NOT INCLUDE MOLDFLASH OF 0.25mm PER SIDE.
5. ALL GROUND LEADS MUST BE SOLDERED TO PCB RF GROUND.

### Package Information

Part Number	Package Body Material	Lead Finish	MSL Rating	Package Marking <sup>[3]</sup>
HMC207S8	Low Stress Injection Molded Plastic	Sn/Pb Solder	MSL1 <sup>[1]</sup>	HMC207 XXXX
HMC207S8E	RoHS-compliant Low Stress Injection Molded Plastic	100% matte Sn	MSL1 <sup>[2]</sup>	HMC207 XXXX

[1] Max peak reflow temperature of 235 °C

[2] Max peak reflow temperature of 260 °C

[3] 4-Digit lot number XXXX

For price, delivery, and to place orders, please contact Hittite Microwave Corporation:  
20 Alpha Road, Chelmsford, MA 01824 Phone: 978-250-3343 Fax: 978-250-3373  
Order On-line at [www.hittite.com](http://www.hittite.com)

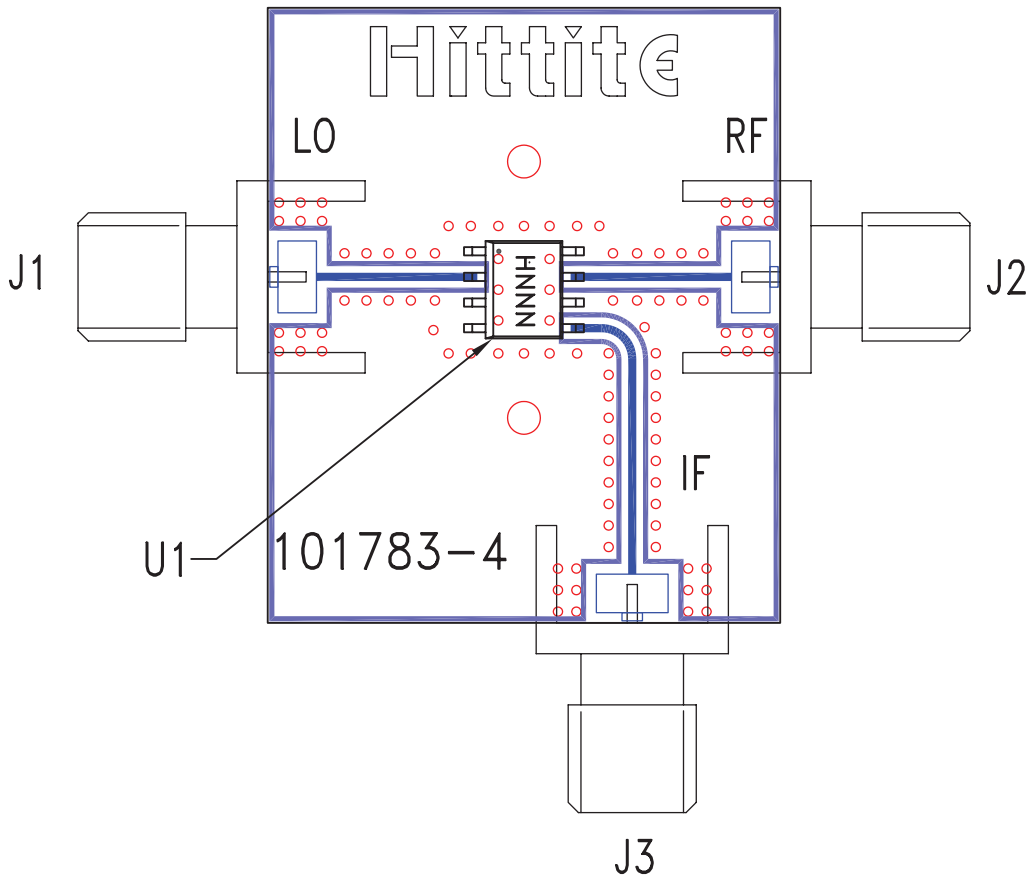
**Evaluation PCB**

**List of Materials for Evaluation PCB 101785 [1]**

Item	Description
J1 - J3	PCB Mount SMA RF Connector
U1	HMC207S8 / HMC207S8E Mixer
PCB [2]	101783 Evaluation Board

[1] Reference this number when ordering complete evaluation PCB

[2] Circuit Board Material: Rogers 4350

The circuit board used in the final application should use RF circuit design techniques. Signal lines should have 50 ohm impedance while the package ground leads should be connected directly to the ground plane similar to that shown. A sufficient number of VIA holes should be used to connect the top and bottom ground planes. The evaluation circuit board shown is available from Hittite upon request.



MICROWAVE CORPORATION v02.0505



## HMC207S8 / 207S8E

*GaAs MMIC SMT DOUBLE-BALANCED MIXER, 0.7 - 2.0 GHz*

**Notes:**

7

MIXERS - SMT