

## HIGH RELIABILITY DC-DC CONVERTER

## HTA-SERIES 200V Input, Single/Dual Output

### Description

The HTA Series of DC-DC converters is a family of 20W, single and dual output, high reliability devices designed to operate in extremely high temperature environments such as those encountered in oil exploration applications. Features include small size, low weight and high tolerance to environmental stresses such as wide temperature extremes, severe shock and vibration. All internal components are derated to meet the intended operating environment. Documentation including electrical stress and thermal analysis are available.

The converters incorporate a fixed frequency single forward topology with magnetic feedback and internal EMI filter. All models include an external inhibit port and have an adjustable output voltage. They are enclosed in a hermetic 3.805" x 1.5" x 0.430" AlSi package and weigh less than 70grams. The package utilizes rugged ceramic feed-thru copper core pins and is sealed using parallel seam welding.

Full environmental screening includes temperature cycling, constant acceleration, fine and gross leak, and burn-in. Non-screened versions of the HTA converters are available for system development purposes. Variations in electrical specifications and screening to meet custom requirements can be accommodated.

### Circuit Description

The HTA series of converters utilize a single-ended forward topology with resonant reset. The nominal switching frequency is 500KHz. Electrical isolation and tight output regulation are achieved through the use of a magnetically coupled feedback.

Output current is limited under any load fault condition to approximately 125% of rated load at maximum operating case temperature. An overload condition causes the converter output to behave like a constant current source with the output voltage dropping below nominal. The converter will resume normal operation when the load current is reduced below the current limit point. This protects the converter from both overload and short circuit conditions.

The current limit point exhibits a slightly negative temperature coefficient to reduce the possibility of thermal runaway.

[www.irf.com](http://www.irf.com)



### Features

- 150 to 250V DC Input Range
- Up to 20W Output Power
- Single and Dual Output Models Include 3.3, 5, 12, 15,  $\pm 5$ ,  $\pm 12$  and  $\pm 15$ V
- Internal EMI Filter
- Magnetically Coupled Feedback
- High Efficiency - to 76%
- -35°C to +185°C Operating Case Temperature Range
- 10M $\Omega$  @ 500VDC Isolation
- Under-Voltage Lockout
- Short Circuit and Overload Protection
- Output Over Voltage Limiter
- Adjustable Output Voltage
- Synchronization Input and Output
- External Inhibit
- Low Weight, < 70grams

### Applications

- Down Hole Exploration Tools

An external Inhibit port is provided to control converter operation. The converter's operation is inhibited when this pin is pulled low. It is designed to be driven by an open collector logic device. The pin may be left open for normal operation and has a nominal open circuit voltage of 4.0V with respect to the Input Return (pin 2).

The output voltage of all models can be adjusted using a single external resistor.

Absolute Maximum Ratings		Maximum Operating Conditions	
Input voltage range	-0.5Vdc to +300Vdc	Input voltage range	150Vdc to 250Vdc
Output power	Internally limited	Output power	0 to Max. Rated
Lead temperature	+300°C for 10 seconds	Operating temperature	-35°C to +185°C
Operating case temperature	-35°C to +185°C		
Storage temperature	-55°C to +185°C		

### Electrical Performance Characteristics

Parameter	Group A Subgroup	Conditions -35°C ≤ T <sub>C</sub> ≤ +185°C V <sub>IN</sub> = 200V DC ± 5%, C <sub>L</sub> = 0 unless otherwise specified	Limits			Unit
			Min	Nom	Max	
Input Voltage			150	200	250	V
Output voltage ( V <sub>OUT</sub> )						
HTA2003R3S	1	I <sub>OUT</sub> = 100% rated load Note 4	3.25	3.30	3.35	V
HTA20005S	1		4.95	5.00	5.05	
HTA20012S	1		11.88	12.00	12.12	
HTA20015S	1		14.85	15.00	15.15	
HTA20005D	1		±4.95	±5.00	±5.05	
HTA20012D	1		±11.88	±12.00	±12.12	
HTA20015D	1	±14.85	±15.00	±15.15		
HTA20003R3S	2,3	I <sub>OUT</sub> = 100% rated load Note 4	3.20		3.40	
HTA20005S	2,3		4.85		5.15	
HTA20012S	2,3		11.64		12.36	
HTA20015S	2,3		14.55		15.45	
HTA20005D	2,3		±4.85		±5.15	
HTA20012D	2,3		±11.64		±12.36	
HTA20015D	2,3	±14.55		±15.45		
Output power ( P <sub>OUT</sub> )	1,2,3	V <sub>IN</sub> = 150, 200, 250 Volts, Note 2	0		20	W
Output current ( I <sub>OUT</sub> )						
HTA20003R3S	1,2,3	V <sub>IN</sub> = 150, 200, 250 Volts, Note 2	0		6.10	A
HTA20005S			0		4.00	
HTA20012S			0		1.67	
HTA20015S			0		1.33	
HTA20005D			0	Either Output, Note 3	3.20	
HTA20012D			0	Either Output, Note 3	1.34	
HTA20015D	0	Either Output, Note 3	1.06			
Line regulation ( V <sub>RLINE</sub> )	1,2,3	V <sub>IN</sub> = 150, 200, 250 Volts I <sub>OUT</sub> = 0, 50%, 100% rated, Note 4	-0.5		+0.5	%
Load regulation ( V <sub>RLOAD</sub> )	1,2,3	I <sub>OUT</sub> = 0, 50%, 100% rated, Note 4 V <sub>IN</sub> = 150, 200, 250 Volts	-1.0		+1.0	%
Cross regulation ( V <sub>RCROSS</sub> )						
HTA20005D	1,2,3	V <sub>IN</sub> = 150, 200, 250 Volts Duals only, Note 5	-5.0		5.0	%
HTA20012D			-3.0		3.0	
HTA20015D			-3.0		3.0	

For Notes to Electrical Performance Characteristics, refer to page 5

Electrical Performance Characteristics ( continued )

Parameter	Group A Subgroup	Conditions -35°C ≤ T <sub>C</sub> ≤ +185°C V <sub>IN</sub> = 200V DC ± 5%, C <sub>L</sub> = 0 unless otherwise specified	Limits			Unit
			Min	Nom	Max	
Input current, no load ( I <sub>IN</sub> ) HTA20003R3S HTA20005S HTA20012S HTA20015S HTA20005D HTA20012D HTA20015D	1,3	I <sub>OUT</sub> = 0, Pin 4 open			20	mA
HTA20003R3S HTA20005S HTA20012S HTA20015S HTA20005D HTA20012D HTA20015D	2	I <sub>OUT</sub> = 0, Pin 4 open			30	mA
Input current inhibited	1,2,3	Pin 4 shorted to pin 2			5.0	mA
Output ripple ( V <sub>RIP</sub> ) HTA20003R3S HTA20005S HTA20012S HTA20015S HTA20005D HTA20012D HTA20015D	1,3	V <sub>IN</sub> = 150, 200, 250 Volts I <sub>OUT</sub> = 100% rated load Notes 4, 6			50 50 70 80 80 80	mV p-p
HTA20003R3S HTA20005S HTA20012S HTA20015S HTA20005D HTA20012D HTA20015D	2	V <sub>IN</sub> = 150, 200, 250 Volts I <sub>OUT</sub> = 100% rated load Notes 4, 6			25 25 35 40 40 40	mV p-p
Switching frequency ( F <sub>S</sub> )	1,2,3	Sync. Input (Pin 4) open	500	550	650	KHz
Efficiency ( E <sub>FF</sub> ) HTA20003R3S HTA20005S HTA20012S HTA20015S HTA20005D HTA20012D HTA20015D	1	I <sub>OUT</sub> = 100% rated load Note 4	70 75 76 76 75 76 76	74 78 79 79 78 79 79		
HTA20003R3S HTA20005S HTA20012S HTA20015S HTA20005D HTA20012D HTA20015D	2	I <sub>OUT</sub> = 100% rated load Note 4	65 70 71 71 70 71 71			%
HTA20003R3S HTA20005S HTA20012S HTA20015S HTA20005D HTA20012D HTA20015D	3	I <sub>OUT</sub> = 100% rated load Note 4	68 73 74 74 73 73 73			

For Notes to Electrical Performance Characteristics, refer to page 5  
www.irf.com

## Electrical Performance Characteristics ( continued )

Parameter	Group A Subgroup	Conditions -35°C ≤ T <sub>c</sub> ≤ +185°C V <sub>IN</sub> = 200V DC ± 5%, C <sub>L</sub> = 0 unless otherwise specified	Limits			Unit
			Min	Nom	Max	
Under Voltage Lockout Turn-on ( input voltage rising ) Turn-off ( input voltage decreasing )	1,2,3  1,2,3	No load, Full load Notes 1, 4	119		146	V
Synchronization Frequency Range Pulse Amplitude, High Pulse Amplitude, Low Pulse Rise Time Pulse Duty Cycle	1,2,3 1,2,3 1,2,3	Note 1	500 2.0 -0.5 20		650 10 0.8 100 80	KHz V V ns %
Transient Recovery Specification		Notes 4, 10, 11, 12				
Transient Load Response Half to Full Load	4,5,6	Overshoot Recovery Time			10 300	% μs
Transient Load Response Full to Half Load	4,5,6	Overshoot Recovery Time			10 450	% μs
Transient Load Response 10% to Half Load	4,5,6	Overshoot Recovery Time			15 300	% μs
Transient Load Response Half to 10% Load	4,5,6	Overshoot Recovery Time			15 450	% μs
Enable Input ( Inhibit Function ) open circuit voltage drive current ( sink ) voltage range	1,2,3	Note 1	3.0 -0.5		5.0 100 50	V μA V
Current Limit Point Expressed as a percentage of full rated load current	1 2 3	V <sub>OUT</sub> = 90% of Nominal, Note 4	115 105 130		175 150 220	%
Power dissipation, load fault ( P <sub>D</sub> )	1,2,3	Short Circuit, Overload, Note 8			30	W
Turn-on Response Overshoot ( V <sub>OS</sub> ) Turn-on Delay ( T <sub>DLY</sub> )	4,5,6	No Load, Full Load Notes 4, 9	2.0		10 200	% ms
Capacitive Load ( C <sub>L</sub> ) HTA20003R3S HTA20005S HTA20012S HTA20015S HTA20005D HTA20012D HTA20015D	1	I <sub>OUT</sub> = 100% rated load No effect on DC performance Notes 1, 4, 7  Each output on duals			2200 1000 180 120 500 90 60	μF
Line Rejection	1	MIL-STD-461, CS101 30Hz to 50KHz, Notes 1, 4	40	50		dB
Isolation	1	Input to Output or Any Pin to Case except pin 3, test @ 500VDC	100			MΩ
Device Weight					70	g

For Notes to Electrical Performance Characteristics, refer to page 5

Notes for Electrical Performance Characteristics Table

1. Parameter is tested as part of design characterization or after design changes. Thereafter, parameter shall be guaranteed to the limits specified.
2. Parameter verified during line and load regulation tests.
3. Output load current must be distributed such that at least 20% of the total load current is being provided by one of the outputs.
4. Load current split equally between outputs on dual output models.
5. Cross regulation is measured with 20% rated load on output under test while changing the load on the other output from 20% to 80% of rated.
6. Guaranteed for a D.C. to 20MHz bandwidth. Tested using a 20KHz to 10MHz bandwidth using the circuit on page 6.
7. Capacitive load may be any value from 0 to the maximum limit without compromising dc performance. A capacitive load in excess of the maximum limit may interfere with the proper operation of the converter's overload protection, causing erratic behavior during turn-on.
8. Overload power dissipation is defined as the device power dissipation with the load set such that  $V_{OUT} = 90\%$  of nominal.
9. Turn-on delay time from either a step application of input power or a logic low to a logic high transition on the inhibit pin (pin 4) to the point where  $V_{OUT} = 90\%$  of nominal.
10. Transient recovery time is from the change in load condition until the output is within 3% of the nominal output voltage.
11. Recovery time is measured from initiation of the transient to where  $V_{OUT}$  has returned to within  $\pm 1\%$  of  $V_{OUT}$  at 50% load.
12. Load transient time  $\geq 10\mu s$ .

**Fig I. Circuit for Measuring Output Ripple Voltage**

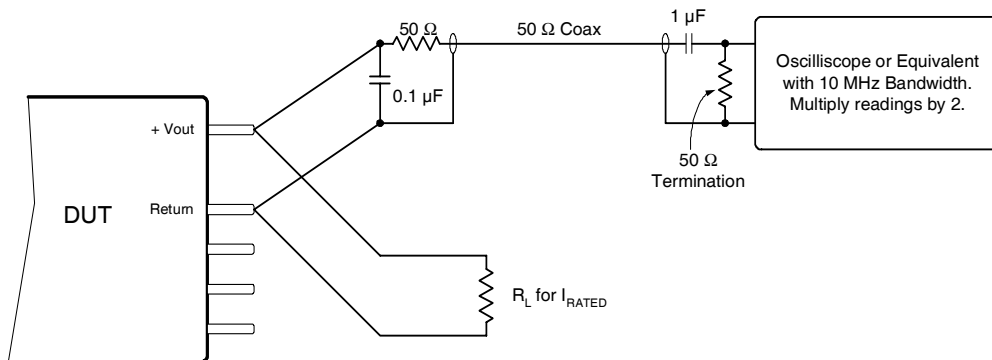

Fig II. Block Diagram - Single Output

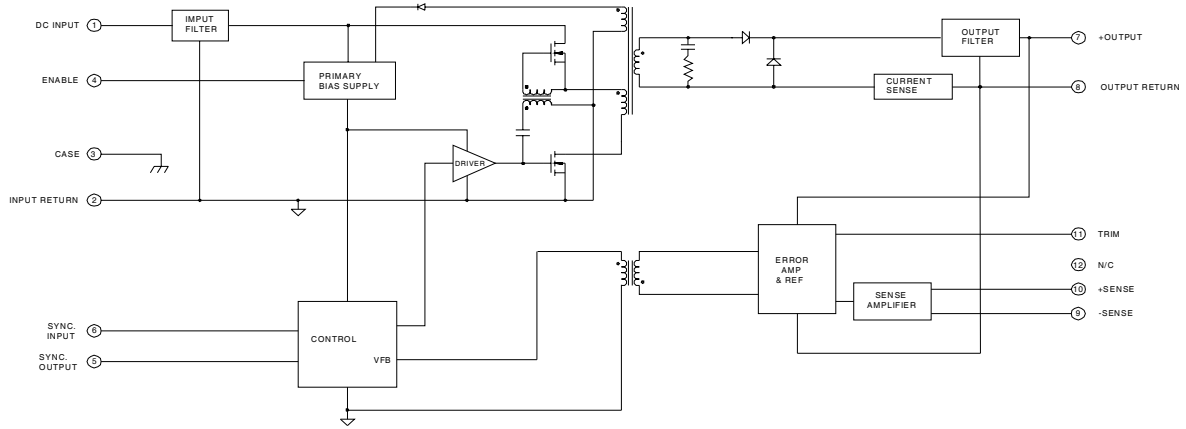
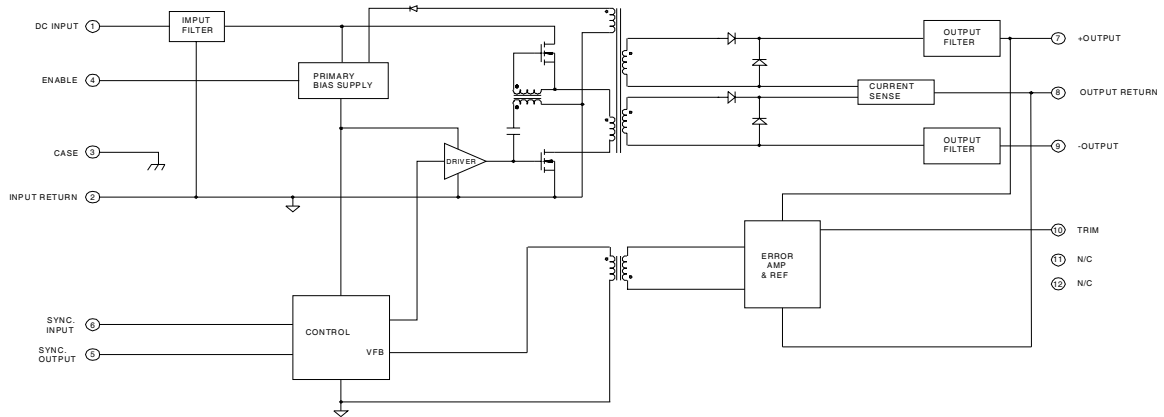

Fig III. Block Diagram - Dual Output



**Technical Notes:**

**Remote Sensing**

This feature is available only for single output models. Connection of the + Sense and - Sense leads at a remotely located load permits compensation for resistive voltage drop between the converter output and the load when they are physically separated by a significant distance. This connection allows regulation to the placard voltage at the point of application. When the remote sensing features is not used, the sense leads should be connected to their respective output terminals at the converter. A combination of the compensation voltage drop and output voltage adjustment (described below in the 'Output Voltage Adjustment' section) is limited to 10% of the nominal output voltage.

**Inhibiting Converter Output**

As an alternative to application and removal of the DC voltage to the input, the user can control the converter output by providing TTL compatible, positive logic signal to Enable pin (pin 4) and to Input Return (pin 2). Enable signal is internally pulled "high" so that when not used, an open connection on the Enable pin permits normal converter operation. When its use is desired, a logical "low" on this port will shut the converter down.

**Synchronization of Multiple Converters**

When operating multiple converters, system requirements often may require operation of the converters at a common frequency. To accommodate this requirement, the HTA series of converters provide both a synchronization input and output.

The Sync Input port permits synchronization of a HTA converter to any compatible external frequency source operating between 500KHz and 650KHz. This input signal should be referenced to the Input Return and have a 10% to 90% duty cycle. Compatibility requires transition times less than 100ns, maximum low level of +0.8V and a minimum high level of +2.0V. The Sync Output of another converter which has been designated as the master oscillator provides a convenient frequency source for this mode of operation. When external synchronization is not required, the Sync In pin should be left unconnected thereby permitting the converter to operate at its own internally set frequency.

The sync output signal is a continuous pulse train set at  $550 \pm 50\text{KHz}$ , with a duty cycle of  $15 \pm 5.0\%$ . This signal is referenced to the Input Return and has been tailored to be compatible with the HTA Sync Input port. Transition times are less than 100ns and the low level output impedance is less than  $50\Omega$ . This signal is active when the DC input voltage is within the specified operating range and the converter is not inhibited. This output has adequate drive reserve to synchronize at least five additional converters.

**Output Voltage Adjust - Single Output Models**

In addition to permitting close voltage regulation of remotely located loads, it is possible to utilize the converter sense pins to incrementally increase the output voltage. The increased output voltage is limited to 10% maximum. The adjustments made possible by this method are intended as a means to "trim" the output to a voltage setting for certain design application, but are not intended to create an adjustable output converter. These output voltage setting variations are obtained by connecting a resistor with an appropriate value between the +Sense and -Sense pins while connecting the -Sense pin to the Output Return pin as shown in Fig IV below. The resistance value for a desired output voltage can be determined by use of the equation presented below.

$$R_{adj} = 100 \cdot \left\{ \frac{V_{NOM}}{V_{OUT} - V_{NOM} \cdot 0.025} \right\}$$

Where  $V_{NOM}$  = device nominal output voltage, and  
 $V_{OUT}$  = desired output voltage

Finding a resistor value for a particular output voltage, is simply a matter of substituting the desired output voltage and the nominal device voltage into the equation and solving for the corresponding resistor value. Under no circumstance should  $R_{ADJ}$  be less than  $500\Omega$ .

Fig IV. Connection for  $V_{OUT}$  Adjustment

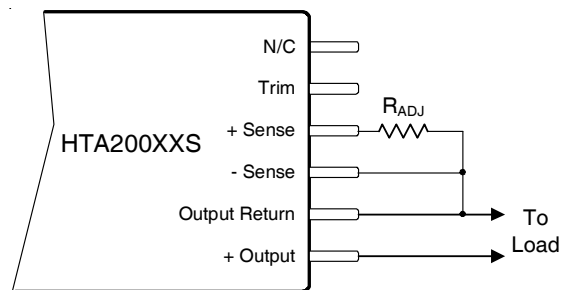

## HTA-SERIES

Examination of the equation relating output voltage and resistor value reveals a special benefit of the circuit topology utilized for remote sensing of output voltage in the HTA200XXS series of converters. It is apparent that as the resistance increases, the output voltage approaches the nominal set value of the device. In fact the calculated limiting value of output voltage as the adjusting resistor becomes very large, is  $\approx 25\text{mV}$  above nominal device voltage.

The consequence is that if the +sense connection is unintentionally broken, an HTA200XXS has a fail-safe output voltage of  $V_{\text{out}} + 25\text{mV}$ , where the  $25\text{mV}$  is independent of the nominal output voltage. It can be further demonstrated that in the event of both the +Sense and -Sense connections being broken, the output will be limited to  $V_{\text{out}} + 440\text{mV}$ . This  $440\text{mV}$  is also essentially constant independent of the nominal output voltage. While operation in this condition is not damaging to the device, not all performance parameters will be met.

### Output Voltage Adjust - Dual Output Models

By use of the Trim pin (10), the magnitude of output voltages can be adjusted over a limited range in either a positive or negative direction. Connecting a resistor between the trim pin and either the output return or the positive output will raise or lower the magnitude of output voltages. The span of output voltage adjustment is restricted to the limits shown in Table I.

Table 1. Output Voltage Trim Values and Limits

HTA20005D		HTA20012D		HTA20015D	
$V_{\text{OUT}}$	$R_{\text{ADJ}}$	$V_{\text{OUT}}$	$R_{\text{ADJ}}$	$V_{\text{OUT}}$	$R_{\text{ADJ}}$
5.5	0	12.5	0	15.5	0
5.4	12.5K	12.4	47.5K	15.4	62.5K
5.3	33.3K	12.3	127K	15.3	167K
5.2	75K	12.2	285K	15.2	375K
5.1	200K	12.1	760K	15.1	1.0M
5.0	$\infty$	12.0	$\infty$	15.0	$\infty$
4.9	190K	11.7	975K	14.6	1.2M
4.8	65K	11.3	288K	14.0	325K
4.7	23K	10.8	72.9K	13.5	117K
4.6	2.5K	10.6	29.9K	13.0	12.5K
4.583	0	10.417	0	12.917	0

Note that the nominal magnitude of output voltage resides in the middle of the table and the corresponding resistor value is set to  $\infty$ . To set the magnitude greater than nominal, the adjust resistor is connected to output return. To set the magnitude less than nominal, the adjust resistor is connected to the +Output. (Refer to Fig V.)

Fig V. Connection for  $V_{\text{OUT}}$  Adjustment

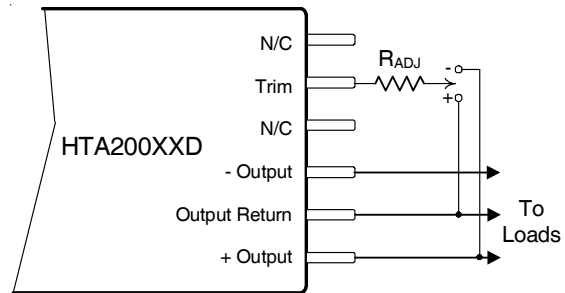

Connect  $R_{\text{ADJ}}$  to + to increase, - to decrease

For output voltage settings that are within the limits, but between those listed in Table I, it is suggested that the resistor values be determined empirically by selection or by use of a variable resistor. The determined value can then be replaced with a good quality fixed resistor for permanent installation.

When use of this adjust feature is elected, the user should be aware that the temperature performance of the converter output voltage will be affected by the temperature performance of the resistor selected as the adjustment element and therefore, is advised to employ resistors with a very small temperature coefficient of resistance.



**Application Notes:**

DC-DC converters constructed with aluminium-silicon (ALSi) controlled expansion alloy benefit from low mass, high thermal conductivity, and CTE match to substrates mounted in them. The one disadvantage over traditional cold rolled steel packages (CRS) however is that the ALSi material is more brittle than the CRS. For this reason, it is important to avoid using a thermal pad or gasket.

The HTA-Series DC-DC converter requires 8-32 size screws and #8 flat washers.

The minimum recommended mounting surface flatness is 0.002" per inch.

The Procedure for mounting the converter is as follows:

1. Check all surfaces for foreign material, burrs, or anything that may interfere with the different parts.
2. Place the converter on the mounting surface and line it up with mounting holes.
3. Install screws using appropriate washers and tighten by hand (~ 4 in.oz) in the sequence shown below in the diagram.
4. Tighten the screws with appropriate torque driver using a controlled torque of up to 20-24 in.lb in the sequence as shown in the diagram.



Efficiency Curves for HTA20003R3S

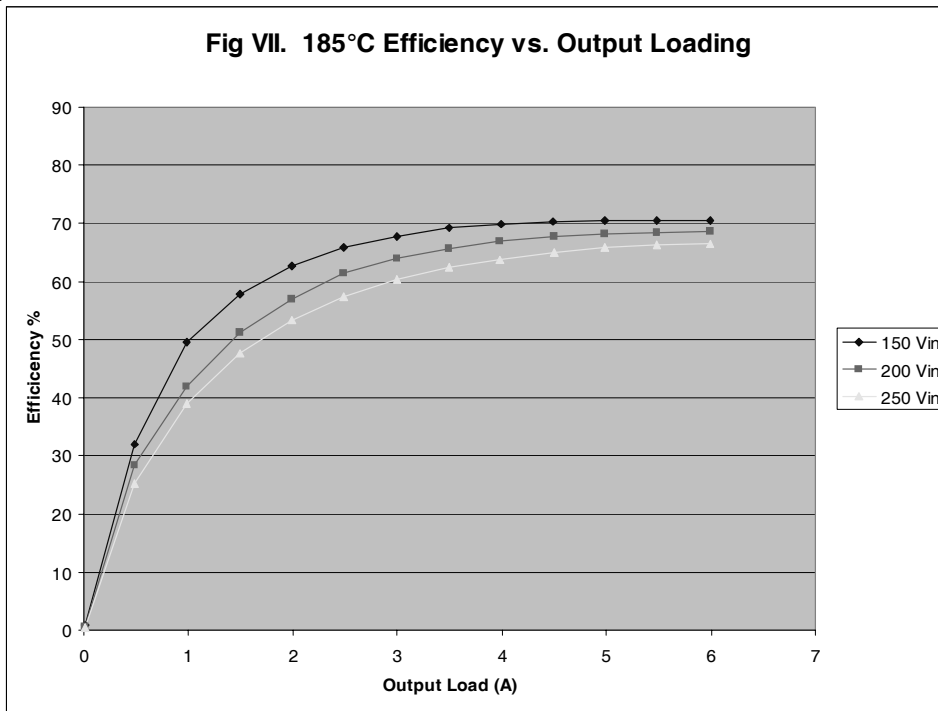
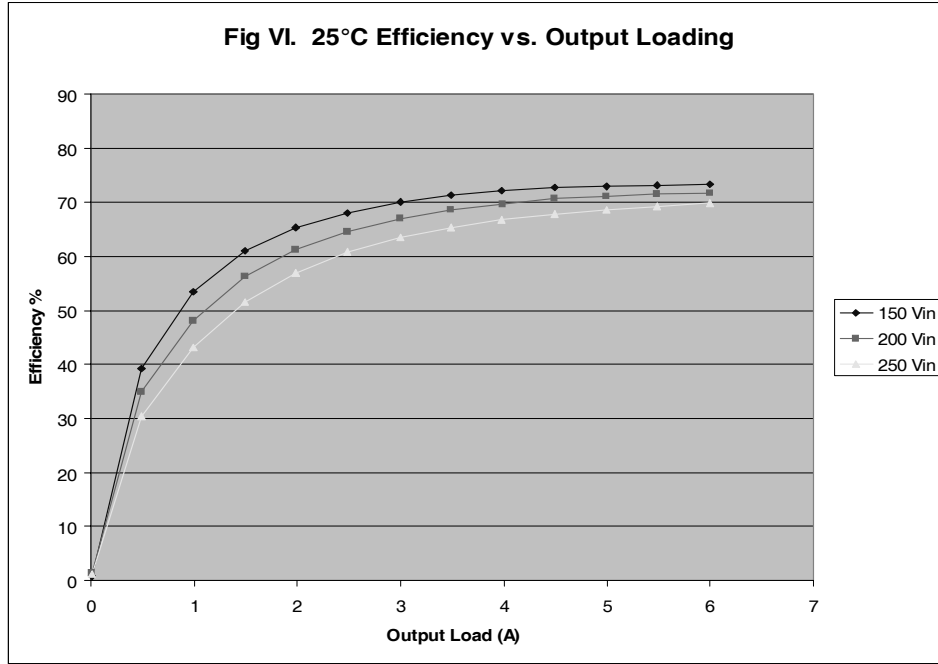

**Efficiency Curve for HTA20003R3S**

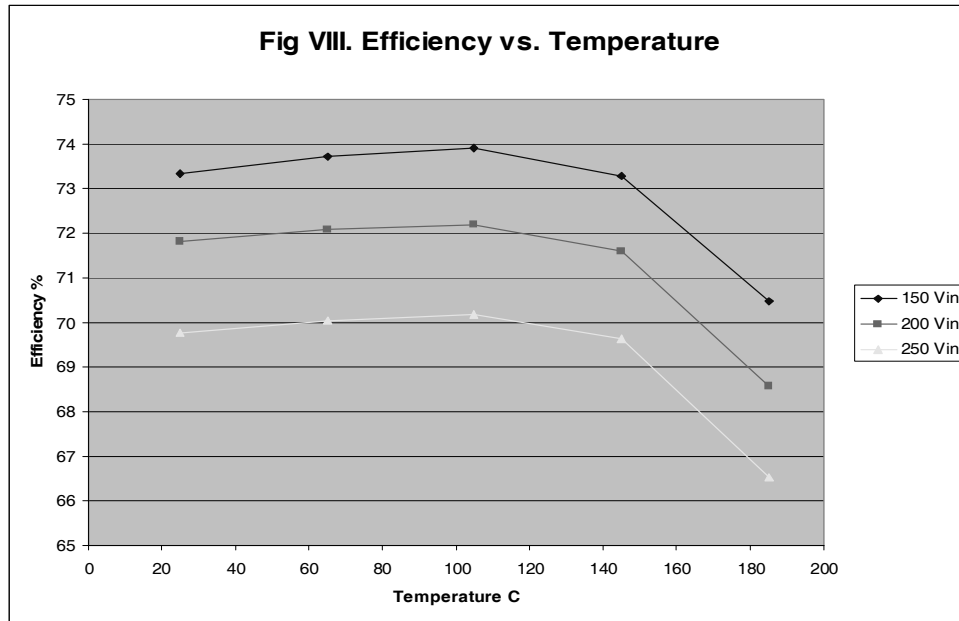

**Efficiency Curve for HTA20005S**

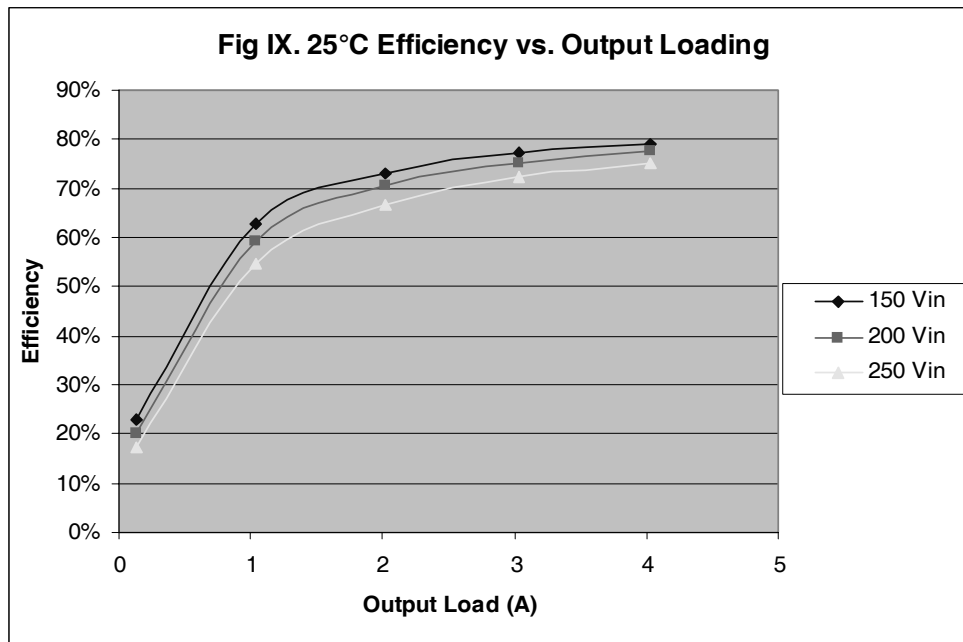

Efficiency Curves for HTA20005S

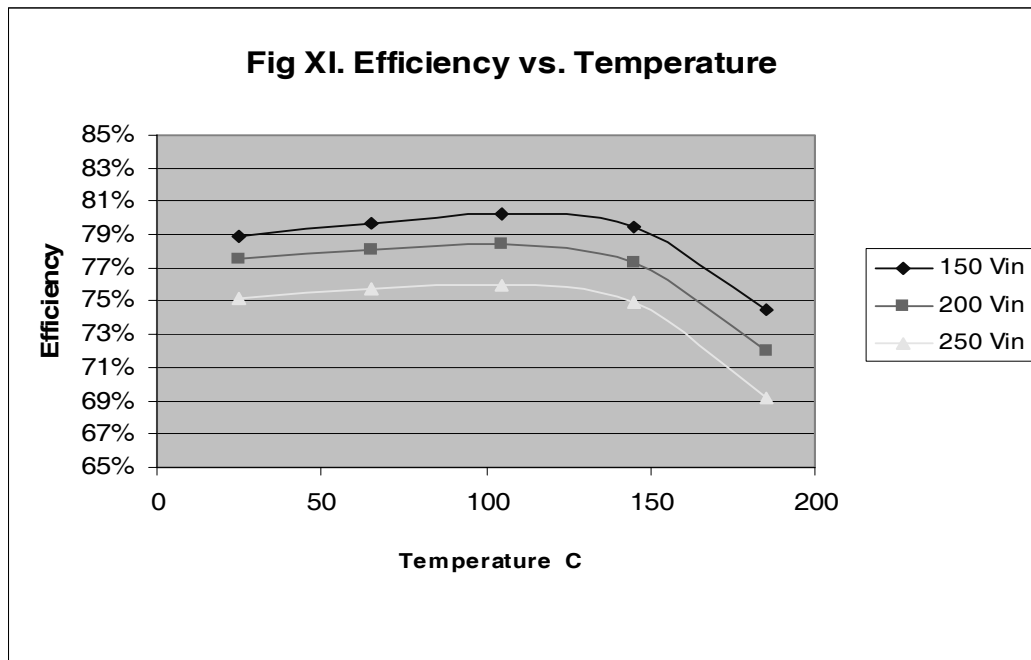
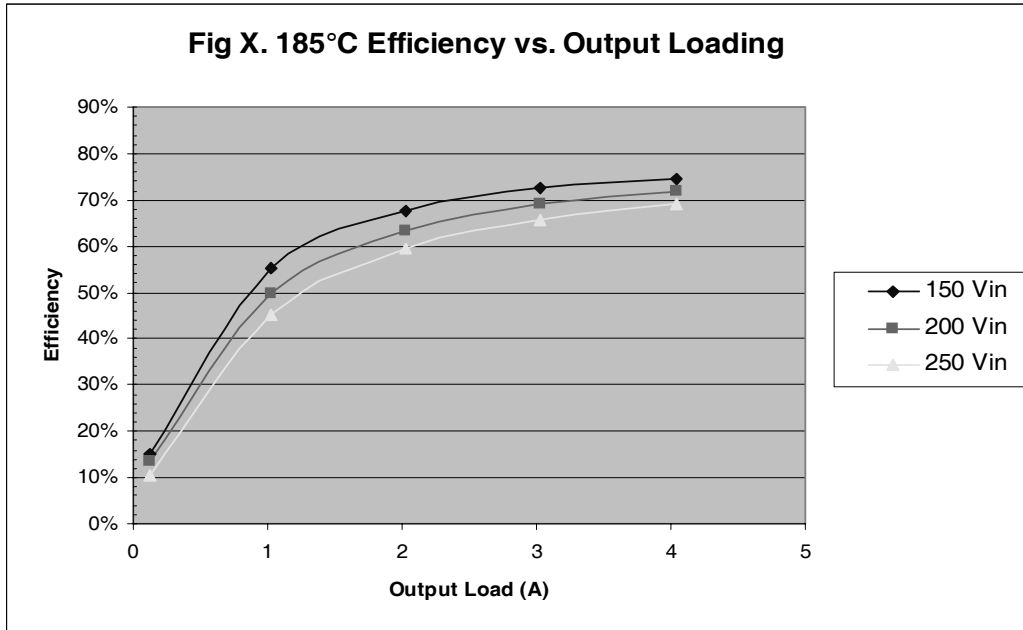

**Mechanical Diagram**

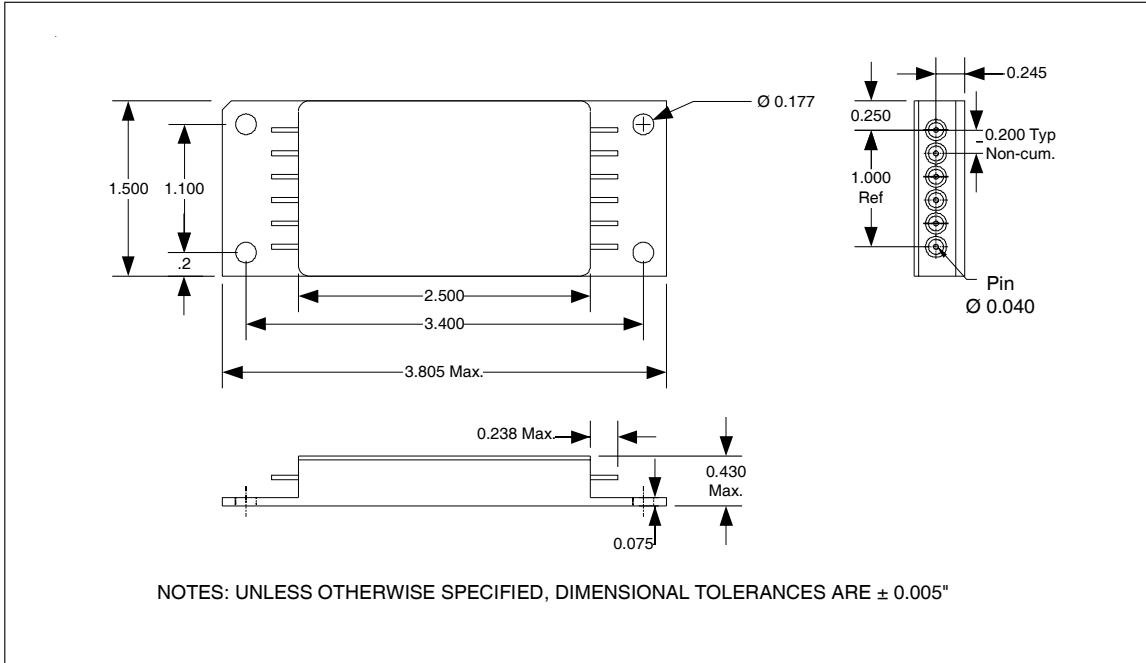

**Pin Designation (Single/Dual)**

Pin #	Single	Dual
1	DC Input	DC Input
2	Input Return	Input Return
3	Case	Case
4	Enable	Enable
5	Sync. Output	Sync. Output
6	Sync. Input	Sync. Input
7	+ Output	+ Output
8	Output Return	Output Return
9	- Sense	- Output
10	+ Sense	N/C
11	Trim *	Trim
12	N/C	N/C

\* Trim pin for Single Output models is reserved for future use.  
 This pin must not be used or connected for any purpose.

**Device Screening**

Requirement	MIL-STD-883 Method	Condition	No Suffix (Production Quality)	/EM suffix (For Engineering Evaluation)
Internal Visual	2017	-	X	X
Seal (Laser Weld)	1014	-	X	X
Fine Leak Test (Unpressurized)	-	-	X	X (For info only)
Gross Leak Test (Unpressurized)	-	-	X	X
Temperature Cycling	1010	-35°C, +185°C, 10 cycles	X	Not required
Electrical	In accordance with device specification	-	X	Not required
Constant Acceleration	2001	3000G for 1 minute	X	Not required
Electrical	In accordance with device specification	-	X	Not required
Burn-in	1015	48 hrs @ 185°C	X	8 hours @ 185°C
Final Electrical (Group A)	In accordance with device specification	-	X	X
Fine Leak Test	1014	A2	X	Not required
Gross Leak Test	1014	C1	X	X
External Visual	2009	-	X	X

**Part Numbering**

