

## Features

- **N-Channel MOSFET**
- **$V_{DSS}$  (Minimum) : 60 V**
- **$R_{DS(ON)}$  (Maximum) : 0.023ohm**
- **$I_D$  : 50 A**
- **$Q_g$  (Typical) : 30 nc**
- **$P_D$  (@TC=25 °C) : 130 W**

## General Description

This power MOSFET is produced in CHMC with advanced VDMOS process, planar stripe. This technology enable power MOSFET to have better characteristics, such as fast switching time, low on resistance, low gate charge and especially excellent avalanche characteristics. It is mainly suitable for half bridge or full bridge resonant topology like a electronic ballast, and also low power switching mode power appliances.

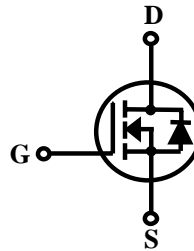
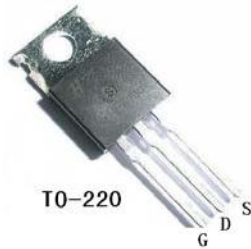

## Absolute Maximum Ratings

Symbol	Parameter	Value	Units
$V_{DSS}$	Drain to Source Voltage	60	V
$I_D$	Continuous Drain Current (@Tc=25°C)	50	A
	Continuous Drain Current (@Tc=100°C)	35	A
$I_{DM}$	Drain Current Pulsed (Note 1)	200	A
$V_{GS}$	Gate to Source Voltage	±20	V
$E_{AS}$	Single Pulsed Avalanche Energy (Note 2)	480	mJ
$E_{AR}$	Repetitive Avalanche Energy (Note 1)	13	mJ
dv/dt	Peak Diode Recovery dv/dt (Note 3)	7	V/ns
$P_D$	Total Power Dissipation (@Tc=25°C)	130	W
	Derating Factor above 25°C	0.9	W/°C
$T_{STG}, T_J$	Operating junction temperature & Storage temperature	-55 ~ +150	°C
$T_L$	Maximum Lead Temperature for soldering purpose, 1/8 from Case for 5 seconds.	300	°C

## Thermal Characteristics

Symbol	Parameter	Value			Units
		Min	Typ	Max	
$R_{\theta JC}$	Thermal Resistance, Junction-to-Case	-	-	1.15	°C/ W
$R_{\theta CS}$	Thermal Resistance, Case-to-Sink	-	0.5	-	°C/ W
$R_{\theta JA}$	Thermal Resistance, Junction-to-Ambient	-	-	62.5	°C/ W

## Electrical Characteristics (Tc=25°C unless otherwise noted)

Symbol	Parameter	Test Conditions	Value			Units
			Min	Typ	Max	
<b>Off Characteristics</b>						
BV <sub>DSS</sub>	Drain- Source Breakdown Voltage	V <sub>GS</sub> =0V, I <sub>D</sub> =250uA	60	-	-	V
$\Delta BV_{DSS}/\Delta T_j$	Breakdown Voltage Temperature coefficient	I <sub>D</sub> =250uA, referenced to 25°C	-	0.07	-	V/°C
I <sub>DSS</sub>	Drain-Source Leakage Current	V <sub>DS</sub> =60V, V <sub>GS</sub> =0V	-	-	1	uA
		V <sub>DS</sub> =48V, Tc=125°C				
I <sub>GSS</sub>	Gate-Source Leakage Current	V <sub>GS</sub> =20V, V <sub>DS</sub> =0V	-	-	100	nA
	Gate-Source Leakage Reverse	V <sub>GS</sub> =-20V, V <sub>DS</sub> =0V	-	-	-100	nA
<b>On Characteristics</b>						
V <sub>GS(th)</sub>	Gate Threshold Voltage	V <sub>DS</sub> =V <sub>GS</sub> , I <sub>D</sub> =250uA	2.0	-	4.0	V
R <sub>DS(ON)</sub>	Static Drain-Source On-state Resistance	V <sub>GS</sub> =10V, I <sub>D</sub> =25A	-	0.018	0.023	ohm
<b>Dynamic Characteristics</b>						
C <sub>iss</sub>	Input Capacitance	V <sub>GS</sub> =0V, V <sub>DS</sub> =25V, f=1MHz	-	900	1220	pF
C <sub>oss</sub>	Output Capacitance		-	430	550	
C <sub>rss</sub>	Reverse Transfer Capacitance		-	80	100	
<b>Dynamic Characteristics</b>						
t <sub>d(on)</sub>	Turn-on Delay Time	V <sub>DD</sub> =30V, I <sub>D</sub> =25A R <sub>G</sub> =50ohm (Note4,5)	-	40	60	ns
t <sub>r</sub>	Rise Time		-	100	200	
t <sub>d(off)</sub>	Turn-off Delay Time		-	90	180	
t <sub>f</sub>	Fall Time		-	80	160	
Q <sub>g</sub>	Total Gate Charge	V <sub>DS</sub> =48V, V <sub>GS</sub> =10V, I <sub>D</sub> =50A (Note4,5)	-	30	40	nC
Q <sub>gs</sub>	Gate-Source Charge		-	9.6	-	
Q <sub>gd</sub>	Gate-Drain Charge (Miller Charge)		-	10	-	

## Source-Drain Diode Ratings and Characteristics

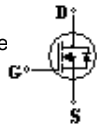
Symbol	Parameter	Test Conditions	Min.	Typ.	Max.	Unit.
I <sub>S</sub>	Continuous Source Current	Integral Reverse p-n Junction Diode in the MOSFET 	-	-	50	A
I <sub>SM</sub>	Pulsed Source Current		-	-	200	
V <sub>SD</sub>	Diode Forward Voltage	I <sub>S</sub> =50A, V <sub>GS</sub> =0V	-	-	1.5	V
t <sub>rr</sub>	Reverse Recovery Time	I <sub>S</sub> =50A, V <sub>GS</sub> =0V, di/dt=100A/us	-	54	-	ns
Q <sub>rr</sub>	Reverse Recovery Charge		-	81	-	uc

### ※NOTES

1. Repeatability rating: pulse width limited by junction temperature
2. L=5.6mH, I<sub>AS</sub>=50A, V<sub>DD</sub>=25V, R<sub>G</sub>=0ohm, Starting T<sub>J</sub>=25°C
3. I<sub>SD</sub>≤50A, di/dt≤300A/us, V<sub>DD</sub>≤BV<sub>DSS</sub>, Starting T<sub>J</sub>=25°C
4. Pulse Test: Pulse Width≤300us, Duty Cycle≤2%
5. Essentially independent of operating temperature.

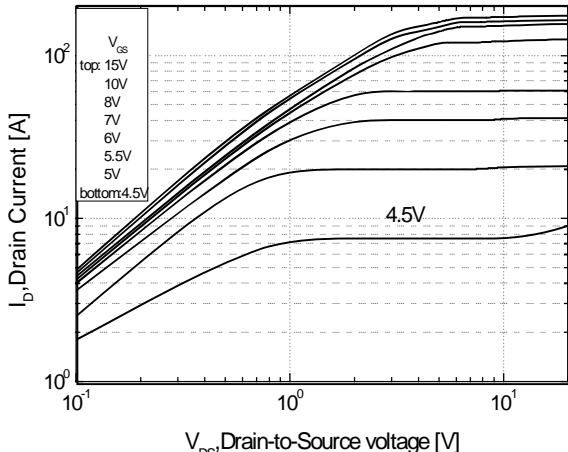

**Fig 1. On-State Characteristics**

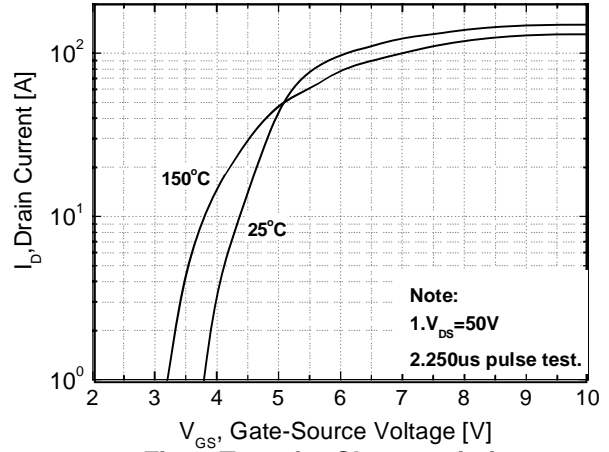

**Fig 2. Transfer Characteristics**

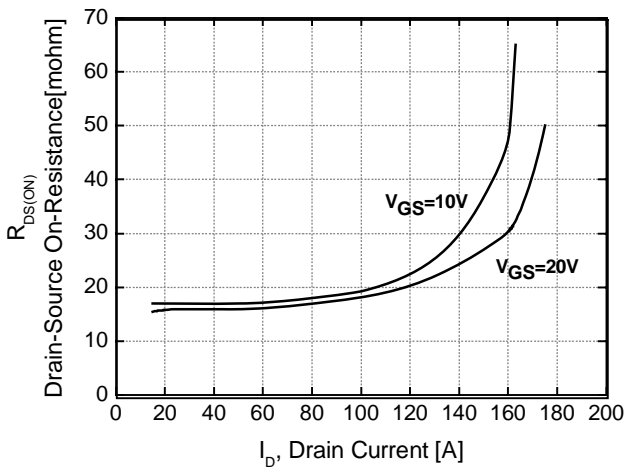

**Fig 3. On Resistance Variation vs. Drain Current and Gate Voltage**

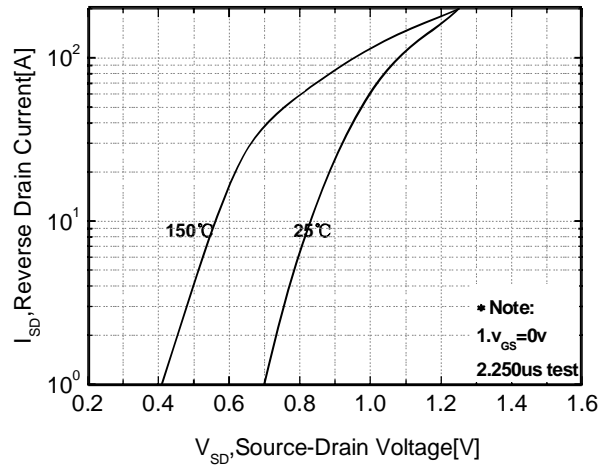

**Fig 4. On State Current vs. Allowable Case Temperature**

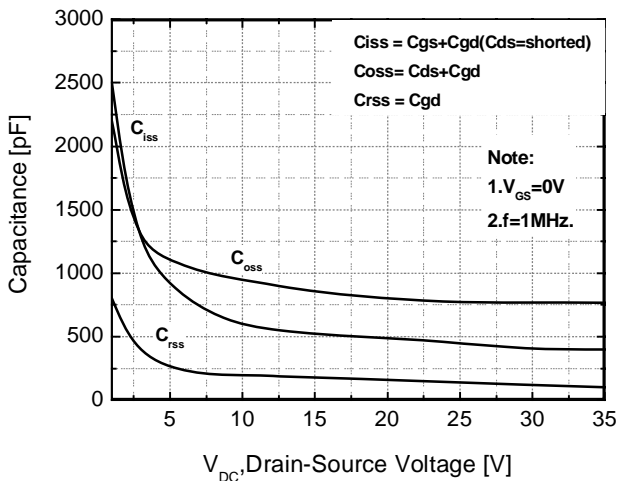

**Fig 5. Capacitance Characteristics (Non-Repetitive)**

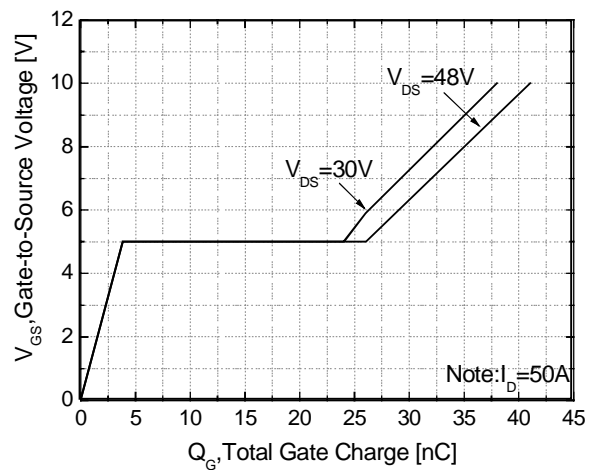

**Fig 6. Gate Charge Characteristics**

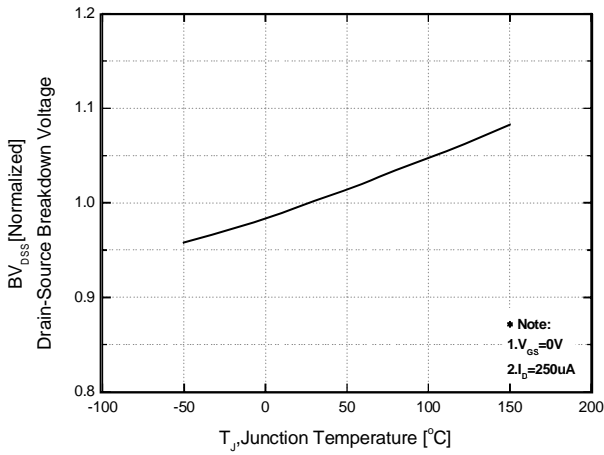

**Fig 7. Breakdown Voltage Variation vs. Junction Temperature**

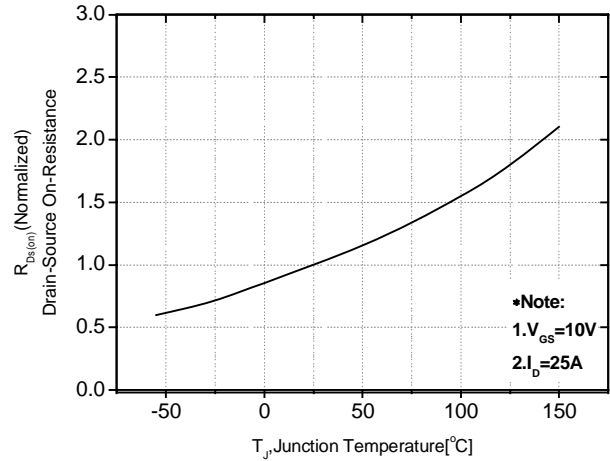

**Fig 8. On-Resistance Variation vs. Junction Temperature**

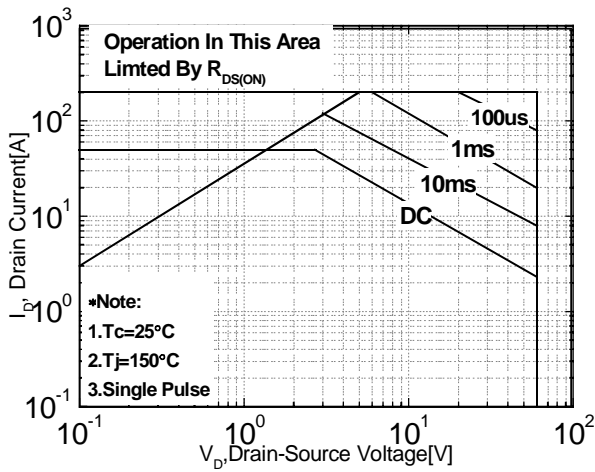

**Fig9. Maximum Safe Operating**

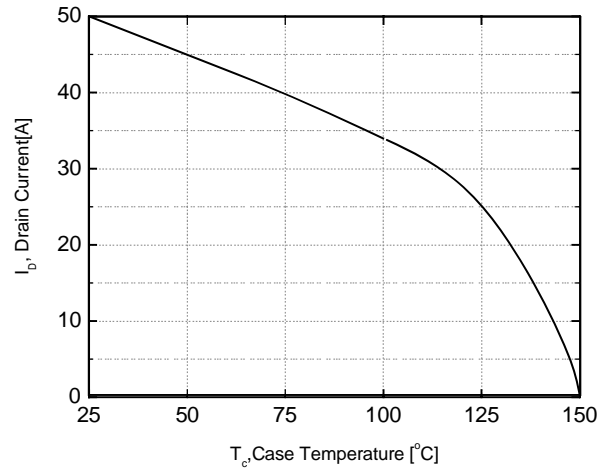

**Fig 10. Maximum Drain Current Vs. Case Temperature**

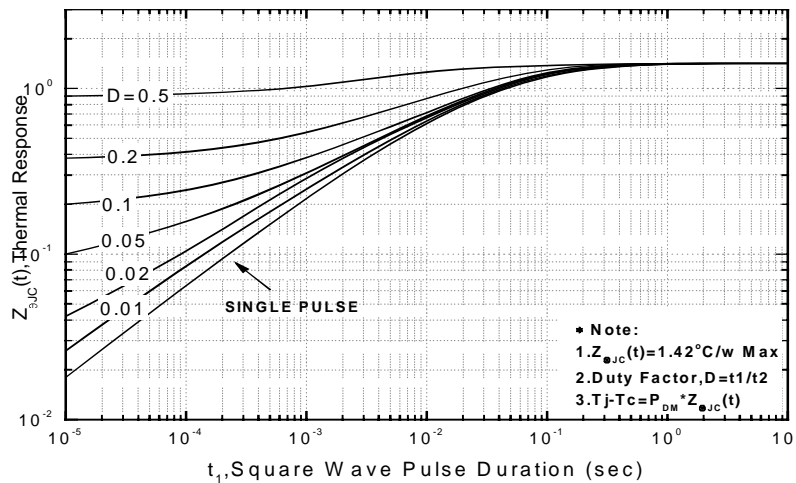

**Fig 11. Transient Thermal Response Curve**

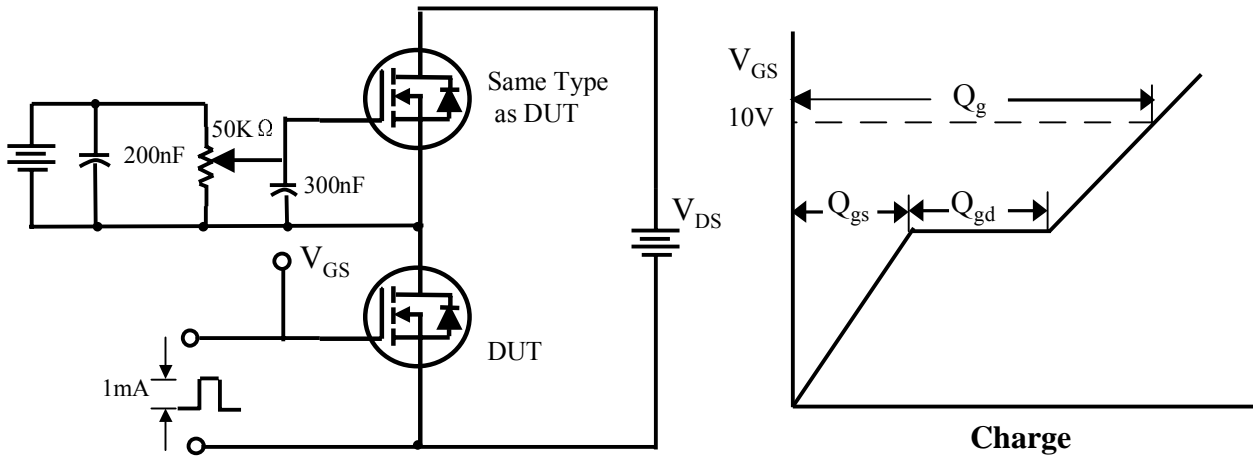

Fig 12. Gate Charge test Circuit & Waveforms

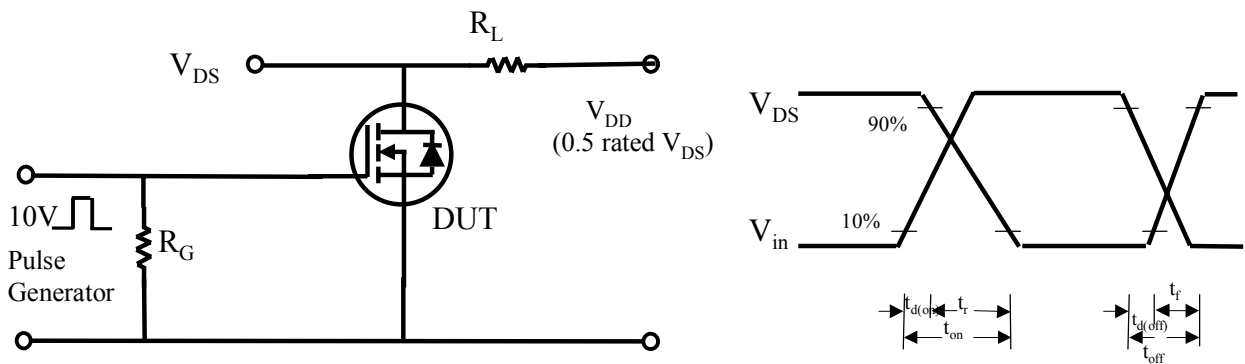

Fig 13. Switching test Circuit & Waveforms

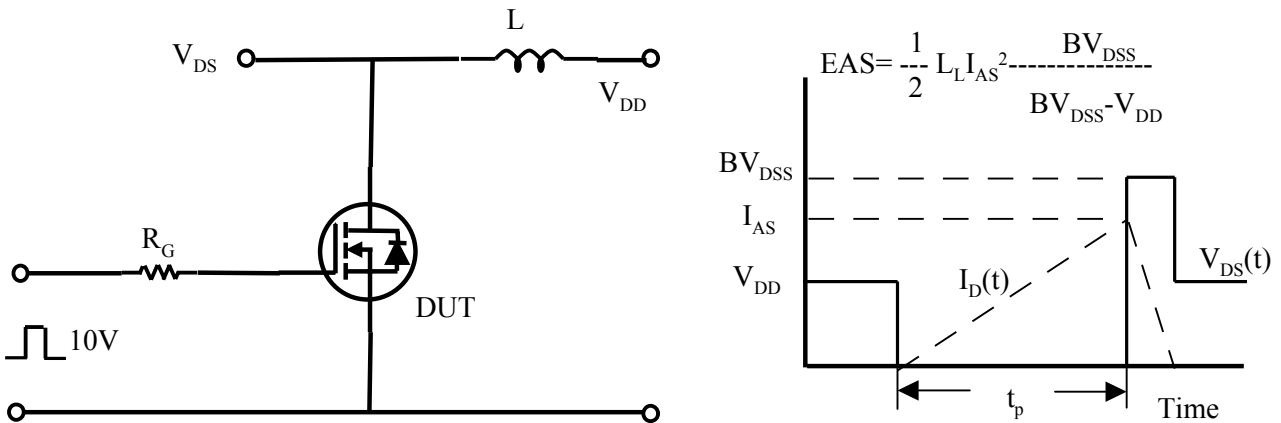
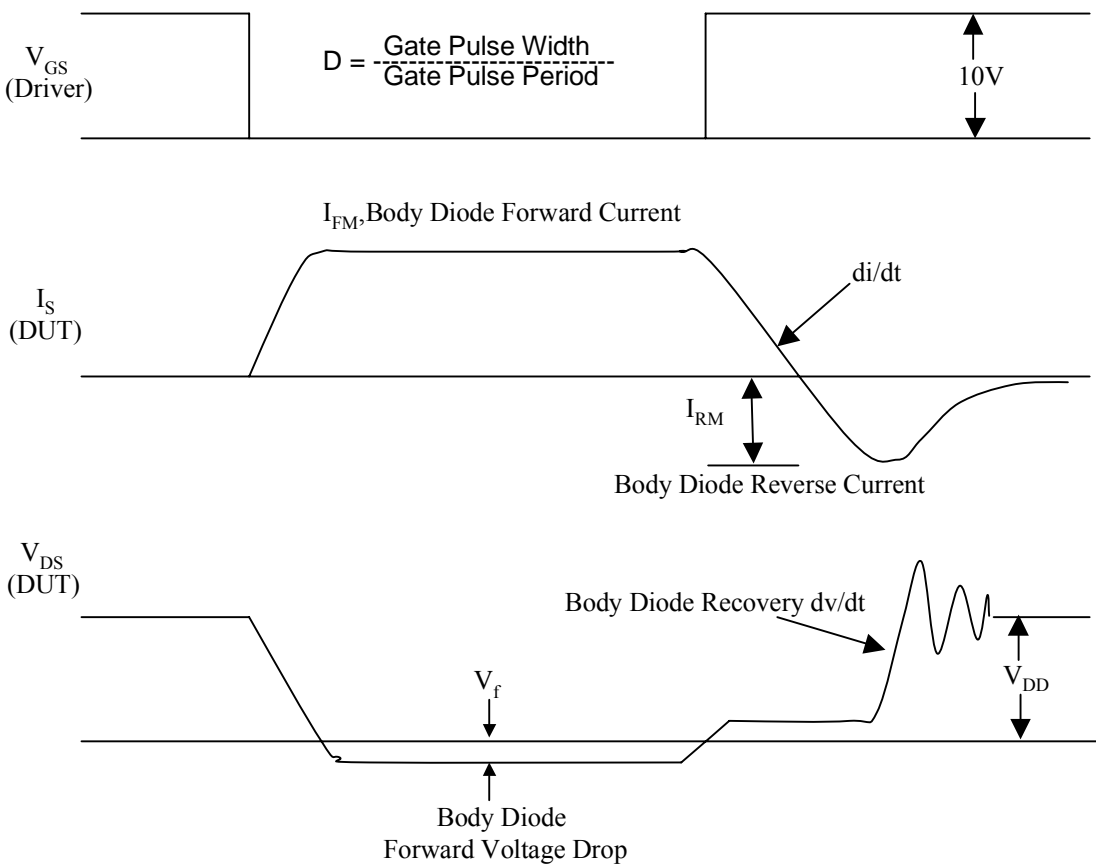
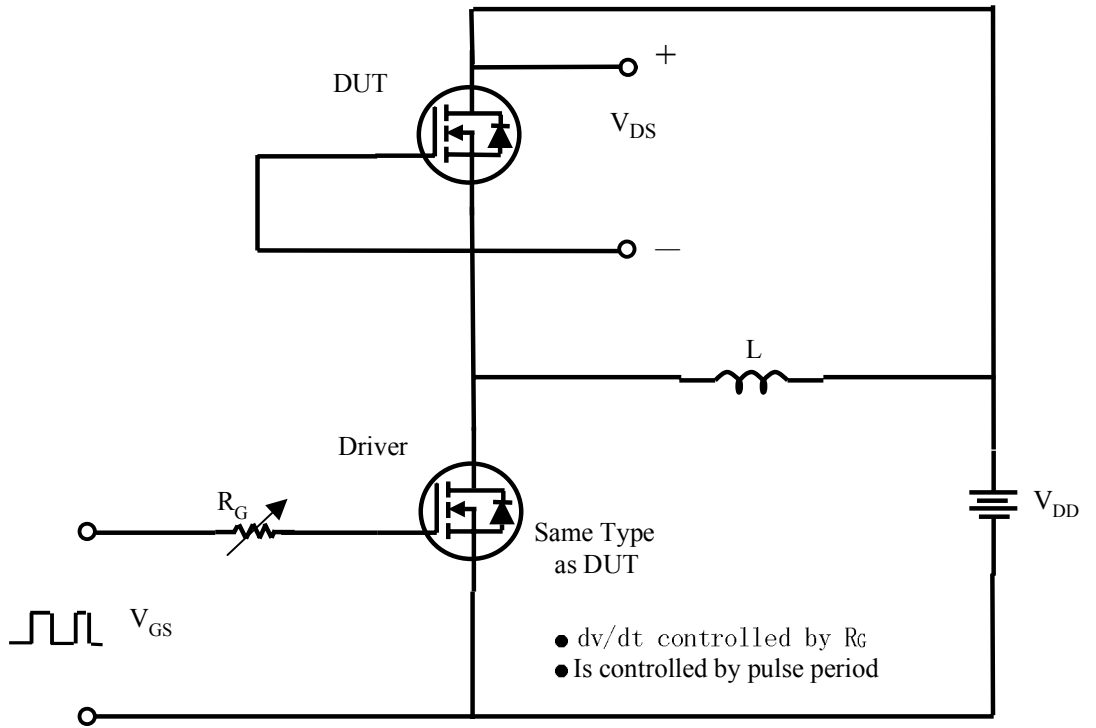

Fig 14. Unclamped Inductive Switching test Circuit & Waveforms



**Fig 15. Peak Diode Recovery dv/dt test Circuit & Waveforms**