

Features

- Output Voltage: 1.5V/1.8V/2.5V/2.8V/3.0V/3.3V/5V
- High Output Voltage Accuracy: $\pm 2\%$
- HT72B25 Low Voltage Drop: 0.34V (Typ.) ($V_{OUT}=2.5V @ I_{OUT}=300mA$)
- Maximum Input Voltage: 7.0V
- Guaranteed Output Current: 300mA
- Low Power Consumption: 18 μ A (Typ.)
- High Ripple Rejection: 70dB (1kHz@ $I_{OUT}=30mA$)
- Power-saving Shutdown Mode
- Over Temperature Protection
- Current Limiting
- SOT23-5, SOT89 Package

Applications

- Portable communication equipment
- Portable music player
- Electrical appliances such as cameras, VCRs and camcorders
- Battery-powered equipment

General Description

The HT72Bxx series are CMOS-based voltage regulator ICs with high output voltage accuracy, low quiescent current, low on Resistance, and high ripple rejection. Each of these ICs consists of a voltage reference unit, an error amplifier, resistor-net for voltage setting, a current limit circuit, a chip enable circuit, and so on.

The HT72Bxx's current limiters' fold back circuit also operates as a short circuit protect function for the output current limiter.

These ICs perform with low dropout voltage and the chip-enable function. The quiescent current of this IC is only 18 μ A, and the line transient response and the load transient response of HT72Bxx are excellent, thus these ICs are very suitable for the power supply for hand-held communication equipment.

The space-saving SOT23-5, SOT89 package will be an attractive additional feature for pocket and hand-held applications.

Selection Table

Part No.	Output Voltage	Tolerance	Package
HT72B15	1.5V	$\pm 2\%$	SOT23-5 SOT89
HT72B18	1.8V		
HT72B25	2.5V		
HT72B28	2.8V		
HT72B30	3.0V		
HT72B33	3.3V		
HT72B50	5.0V		

Block Diagram

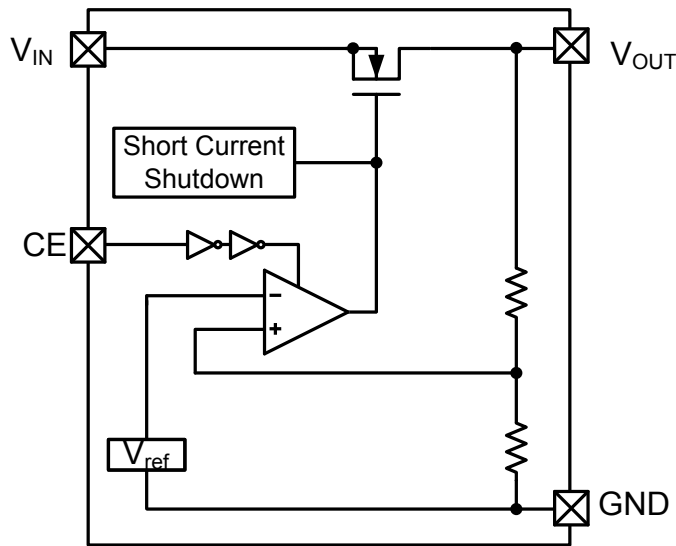

Absolute Maximum Ratings (Note 1)

Maximum Input Supply Voltage.....7.5V
 Ambient Temperature Range.....-40°C~+85°C

Thermal Information

Symbol	Parameter	Package	Max.	Unit
θ_{JA}	Thermal Resistance (Junction to Ambient) (Assume no ambient airflow, no heat sink)	SOT23-5	500	°C/W
		SOT89	200	°C/W
P_D	Power Dissipation	SOT23-5	0.20	W
		SOT89	0.50	W

Note: P_D is measured at $T_a = 25^\circ\text{C}$

Pin Assignment

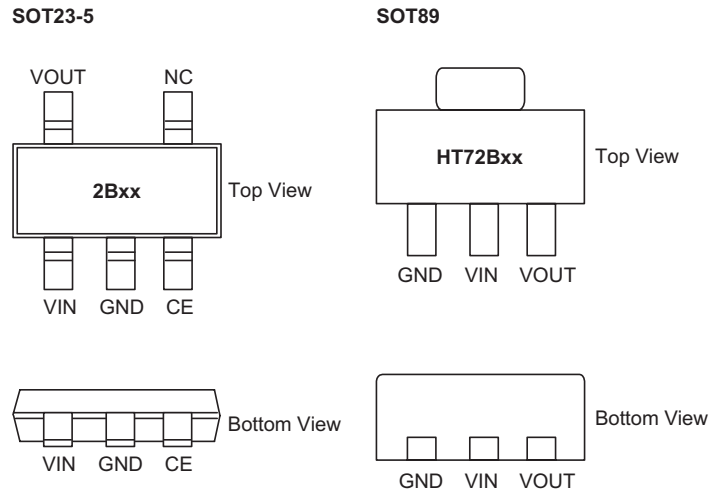

Pin Descriptions

SOT23-5 Pin Descriptions		
Pin No.	Symbol	Description
1	VIN	Input Pin
2	GND	Ground Pin
3	CE	Chip Enable Pin, high enable
4	NC	No Connection
5	VOUT	Output Pin

SOT89 Pin Descriptions		
Pin No.	Symbol	Description
1	GND	Ground Pin
2	VIN	Input Pin
3	VOUT	Output Pin

Electrical Characteristics

Ta=25°C, V_{IN}=V_{OUT}+1V, I_{OUT}=30mA, unless otherwise specified(Note 2)

Symbol	Parameter	Test Conditions	Min.	Typ.	Max.	Unit	
V _{IN}	Input Voltage	1.5V≤V _{OUT} ≤5.0V	2.5	—	7	V	
ΔV _{OUT}	Output Voltage Tolerance	1mA≤I _{OUT} ≤30mA	-2	—	+2	%	
ΔV _{LINE}	Line Regulation	V _{OUT} +0.5V≤V _{IN} ≤7V I _{OUT} =10mA	—	0.02	0.1	%/V	
ΔV _{LOAD}	Load Regulation(Note 3)	1mA≤I _{OUT} ≤300mA	1.5V≤V _{OUT} ≤1.8V	—	13	30	mV
			2.5V≤V _{OUT} ≤3.0V	—	14	35	
			V _{OUT} ≥3.3V	—	15	40	
V _{DROP}	Dropout Voltage(Note 4)	ΔV _{OUT} =2% I _{OUT} =300mA	1.5V≤V _{OUT} ≤1.8V	—	0.6	0.9	V
			2.5V≤V _{OUT} ≤5.0V	—	0.34	0.64	
I _{SHORT}	Short Current Limit	V _{OUT} =0V	—	90	—	mA	
I _{SS}	Supply Current	I _{OUT} =0mA	—	18	30	μA	
I _{SD}	Shutdown Current	CE=GND	—	0.1	1	μA	
V _{IH}	CE Input High Threshold	V _{OUT} +1V≤V _{IN} ≤7V	1	—	7	V	
V _{IL}	CE Input Low Threshold	V _{OUT} +1V≤V _{IN} ≤7V	0	—	0.3	V	
RR	Ripple Rejection	I _{OUT} =30mA	f=1kHz	—	70	—	dB
			f=10kHz	—	53	—	
V _{NOISE}	Output Noise	Bandwidth=10Hz to 100KHz	—	30	—	μVrms	
T _C	Temperature Coefficient	T _C = $\frac{\Delta V_{OUT}}{\Delta T_a \bullet V_{OUT}}$, I _{OUT} =30mA, -40°C≤Ta≤85°C	—	±100	—	ppm/°C	
T _{SD}	Thermal Shutdown Temperature	—	—	150	—	°C	

Note: 1. Absolute maximum ratings indicate limits beyond which damage to the device may occur. Operating Ratings indicate conditions for which the device is intended to be functional, but do not guarantee specific performance limits. The guaranteed specifications apply only for the test conditions listed.

2. Specifications are production tested at T_A=room temperature. Specifications over the -40°C to 85°C operating temperature range are assured by design, characterization and correlation with Statistical Quality Controls (SQC).

3. Load regulation is measured at constant junction temperature, using pulse testing with a short ON time. Guaranteed up to the maximum power dissipation. Power dissipation is determined by the input/output differential voltage and the output current. Guaranteed maximum power dissipation will not be available over the full input/output range. The maximum allowable power dissipation at any ambient temperature is P_D=(T_{J(MAX)}-T_A)/θ_{JA}.

4. Dropout voltage is the minimum input to output voltage differential needed to maintain regulation at a specified output current. In dropout, the output voltage will be equal to: V_{IN}-V_{DROP}.

Application Circuit

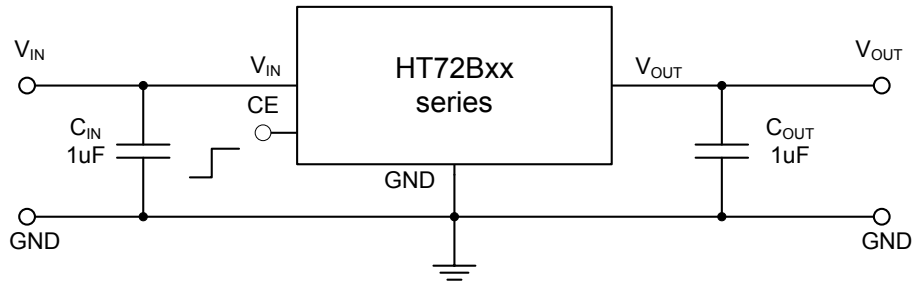
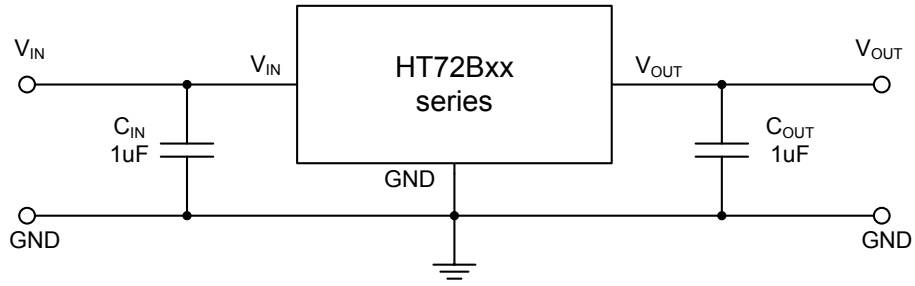

Typical Characteristics

Supply Current vs. Input Current

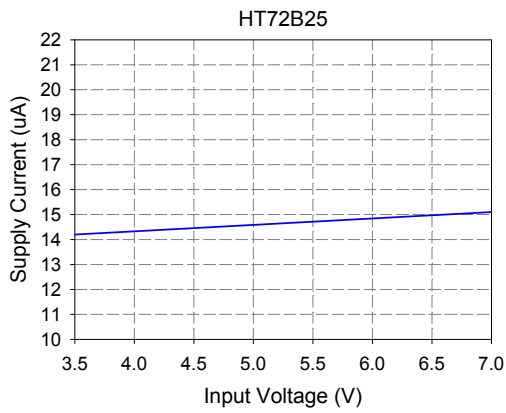
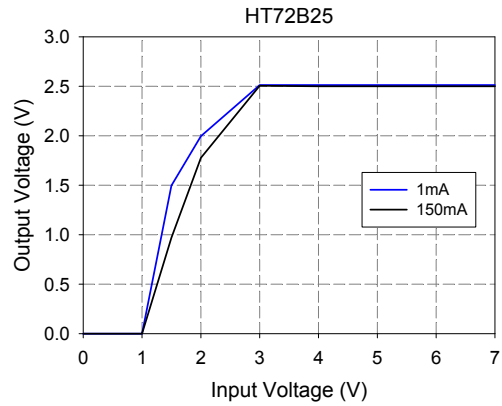
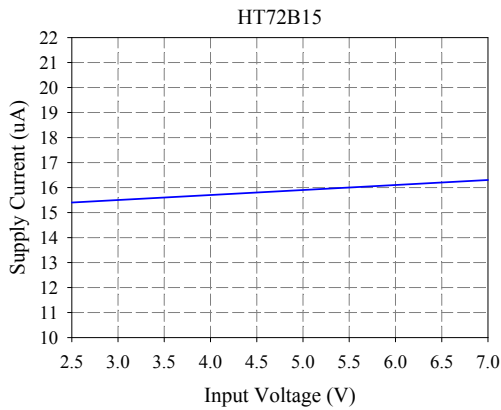

Output Voltage vs. Temperature

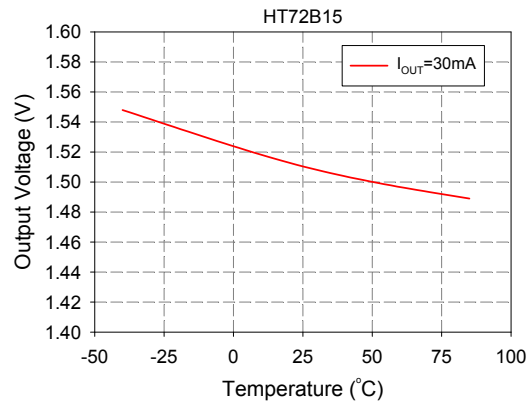

Output Voltage vs. Input Voltage

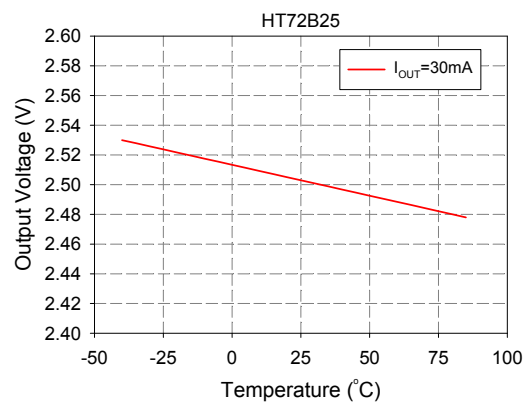
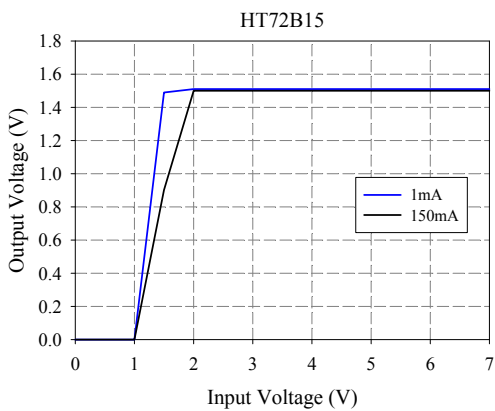

Supply Current vs. Temperature

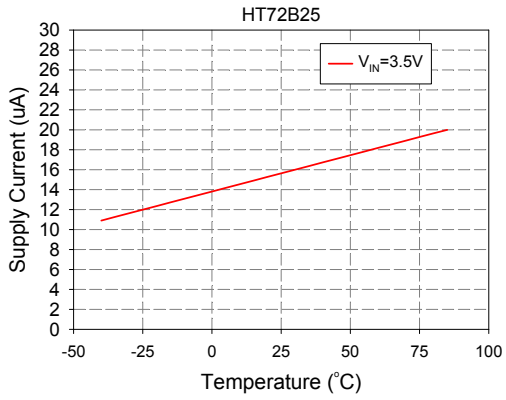
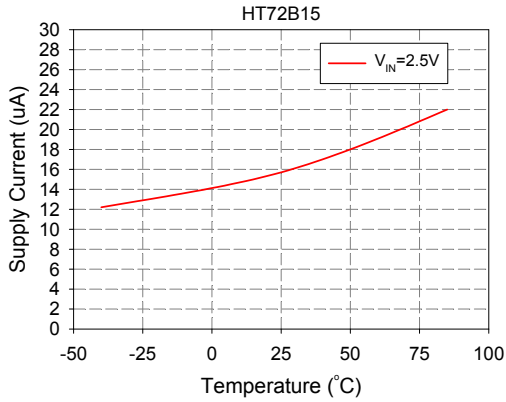

Ripple Rejection vs. Frequency

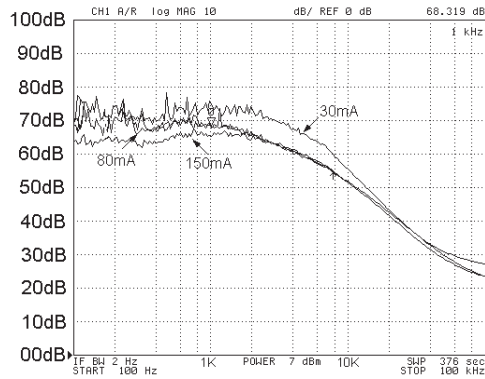

Load Transient Response

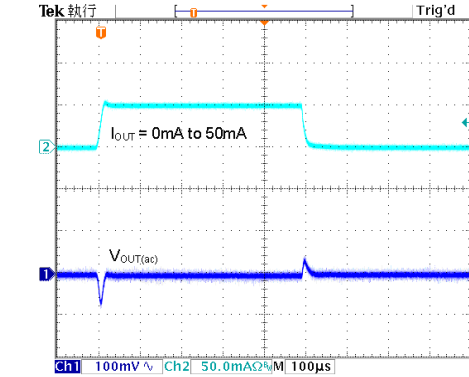

HT72B15 $V_{IN}=2.5V$, $C_{IN}=C_{OUT}=1\mu F$, CH1= $V_{OUT(ac)}$, CH2= I_{OUT}

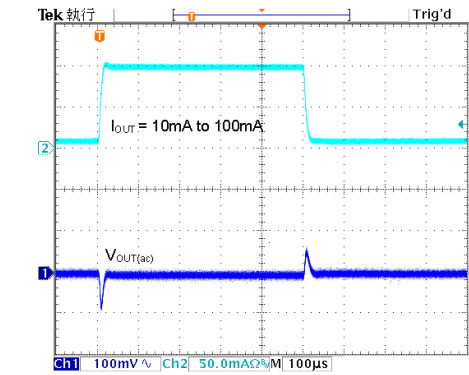

HT72B15 $V_{IN}=2.5V$, $C_{IN}=C_{OUT}=1\mu F$, CH1= $V_{OUT(ac)}$, CH2= I_{OUT}

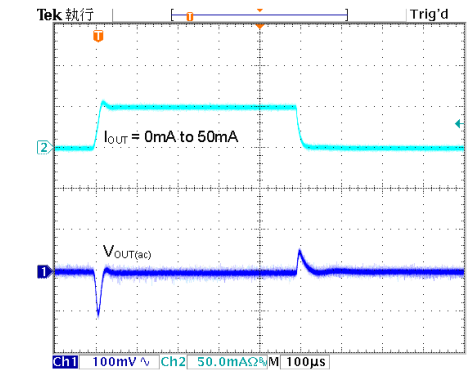

HT72B25 $V_{IN}=3.5V$, $C_{IN}=C_{OUT}=1\mu F$, CH1= $V_{OUT(ac)}$, CH2= I_{OUT}

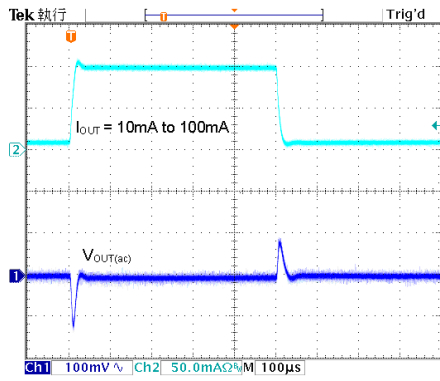

HT72B25 $V_{IN}=3.5\text{V}$, $C_{IN}=C_{OUT}=1\mu\text{F}$, CH1= $V_{OUT(ac)}$,
CH2= I_{OUT}

Package Information

5-pin SOT23-5 Outline Dimensions

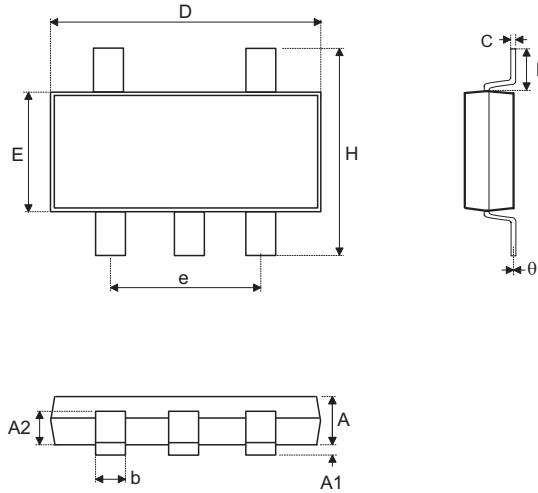

Symbol	Dimensions in inch		
	Min.	Nom.	Max.
A	0.039	—	0.051
A1	—	—	0.004
A2	0.028	—	0.035
b	0.014	—	0.020
C	0.004	—	0.010
D	0.106	—	0.122
E	0.055	—	0.071
e	—	0.075	—
H	0.102	—	0.118
L	0.015	—	—
θ	0°	—	9°

Symbol	Dimensions in mm		
	Min.	Nom.	Max.
A	1.00	—	1.30
A1	—	—	0.10
A2	0.70	—	0.90
b	0.35	—	0.50
C	0.10	—	0.25
D	2.70	—	3.10
E	1.40	—	1.80
e	—	1.90	—
H	2.60	—	3.0
L	0.37	—	—
θ	0°	—	9°

3-pin SOT89 Outline Dimensions

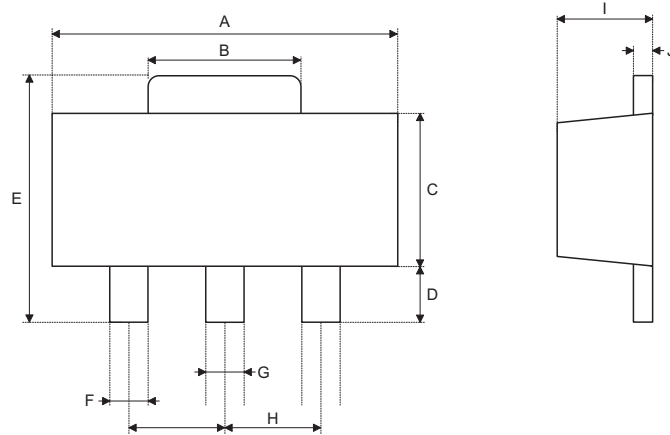

Symbol	Dimensions in inch		
	Min.	Nom.	Max.
A	0.173	—	0.181
B	0.059	—	0.072
C	0.090	—	0.102
D	0.035	—	0.047
E	0.155	—	0.167
F	0.014	—	0.019
G	0.017	—	0.022
H	—	0.059	—
I	55	—	63
J	14	—	17

Symbol	Dimensions in mm		
	Min.	Nom.	Max.
A	4.39	—	4.60
B	1.50	—	1.83
C	2.29	—	2.59
D	0.89	—	1.19
E	3.94	—	4.24
F	0.36	—	0.48
G	0.43	—	0.56
H	—	1.50	—
I	1.40	—	1.60
J	0.36	—	0.43

Reel Dimensions

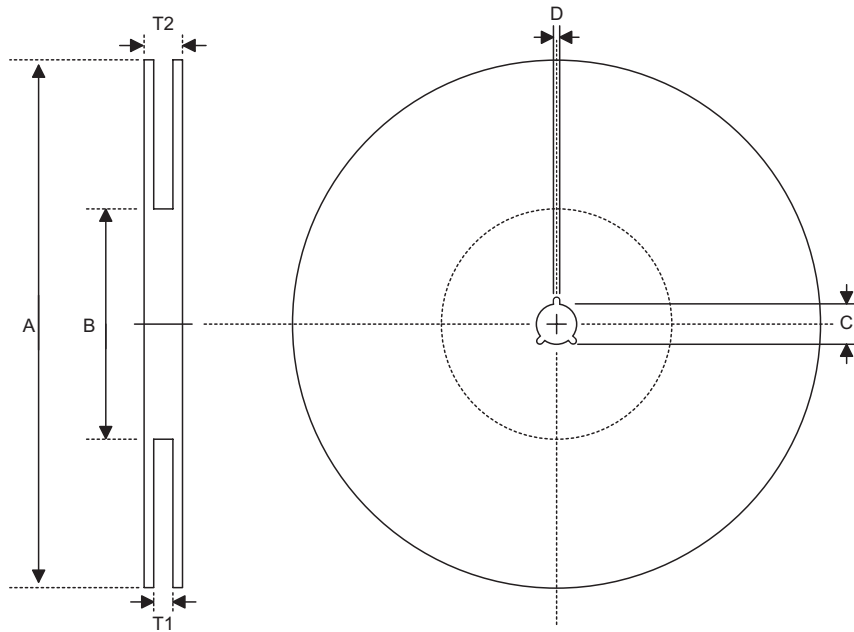

SOT23-5

Symbol	Description	Dimensions in mm
A	Reel Outer Diameter	178.0±1.0
B	Reel Inner Diameter	62.0±1.0
C	Spindle Hole Diameter	13.0±0.2
D	Key Slit Width	2.50±0.25
T1	Space Between Flang	8.4 ^{+1.5/-0.0}
T2	Reel Thickness	11.4 ^{+1.5/-0.0}

SOT89-3

Symbol	Description	Dimensions in mm
A	Reel Outer Diameter	180.0±1.0
B	Reel Inner Diameter	62.0±1.5
C	Spindle Hole Diameter	12.75 ^{+0.15/-0.00}
D	Key Slit Width	1.9±0.15
T1	Space Between Flang	12.4 ^{+0.2/-0.0}
T2	Reel Thickness	17.0 ^{+0.0/-0.4}

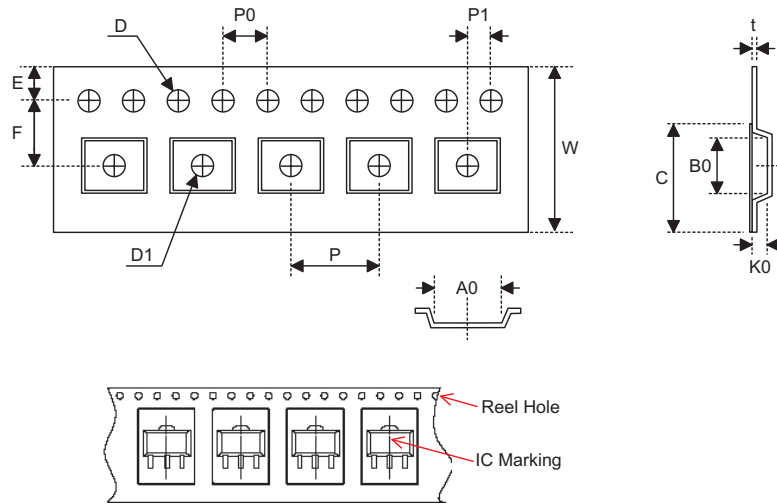
Carrier Tape Dimensions

SOT23-5

Symbol	Description	Dimensions in mm
W	Carrier Tape Width	8.0±0.3
P	Cavity Pitch	4.0±0.1
E	Perforation Position	1.75±0.10
F	Cavity to Perforation(Width Direction)	3.50±0.05
D	Perforation Diameter	1.5 ^{+0.1/-0.0}
D1	Cavity Hole Diameter	1.5 ^{+0.1/-0.0}
P0	Perforation Pitch	4.0±0.1
P1	Cavity to Perforation(Length Direction)	2.00±0.05
A0	Cavity Length	3.15±0.10
B0	Cavity Width	3.2±0.1
K0	Cavity Depth	1.4±0.1
t	Carrier Tape Thickness	0.20±0.03
C	Cover Tape Width	5.3±0.1

SOT89-3

Symbol	Description	Dimensions in mm
W	Carrier Tape Width	12.0 ^{+0.3/-0.1}
P	Cavity Pitch	8.0±0.1
E	Perforation Position	1.75±0.10
F	Cavity to Perforation(Width Direction)	5.50±0.05
D	Perforation Diameter	1.5±0.1
D1	Cavity Hole Diameter	1.5±0.1
P0	Perforation Pitch	4.0±0.1
P1	Cavity to Perforation(Length Direction)	2.0±0.1
A0	Cavity Length	4.8±0.1
B0	Cavity Width	4.5±0.1
K0	Cavity Depth	1.8±0.1
t	Carrier Tape Thickness	0.300±0.013
C	Cover Tape Width	9.3±0.1

Holtek Semiconductor Inc. (Headquarters)

No.3, Creation Rd. II, Science Park, Hsinchu, Taiwan
Tel: 886-3-563-1999
Fax: 886-3-563-1189
<http://www.holtek.com.tw>

Holtek Semiconductor Inc. (Taipei Sales Office)

4F-2, No. 3-2, YuanQu St., Nankang Software Park, Taipei 115, Taiwan
Tel: 886-2-2655-7070
Fax: 886-2-2655-7373
Fax: 886-2-2655-7383 (International sales hotline)

Holtek Semiconductor Inc. (Shenzhen Sales Office)

5F, Unit A, Productivity Building, No.5 Gaoxin M 2nd Road, Nanshan District, Shenzhen, China 518057
Tel: 86-755-8616-9908, 86-755-8616-9308
Fax: 86-755-8616-9722

Holtek Semiconductor (USA), Inc. (North America Sales Office)

46729 Fremont Blvd., Fremont, CA 94538, USA
Tel: 1-510-252-9880
Fax: 1-510-252-9885
<http://www.holtek.com>

Copyright© 2011 by HOLTEK SEMICONDUCTOR INC.

The information appearing in this Data Sheet is believed to be accurate at the time of publication. However, Holtek assumes no responsibility arising from the use of the specifications described. The applications mentioned herein are used solely for the purpose of illustration and Holtek makes no warranty or representation that such applications will be suitable without further modification, nor recommends the use of its products for application that may present a risk to human life due to malfunction or otherwise. Holtek's products are not authorized for use as critical components in life support devices or systems. Holtek reserves the right to alter its products without prior notification. For the most up-to-date information, please visit our web site at <http://www.holtek.com.tw>.