

Datasheet

8 Gbps Bi-Directional SFP+ Transceiver

SFP-8GD-LR



Features

- Designed for SFF-8472 compliance (SFP)
- Up to 8.5 Gbps data rates
 - 2.125/4.25/8.5 Gbps Fibre Channel
- Single-mode optics (Duplex LC)
- Dual-fiber, bi-directional
- Class 1 laser (Tx): 1310 nm
- Up to 10 km on 9/125 µm SMF
- Digital Diagnostics (SFF-8472)
- Commercial operating temperature range
- RoHS compliant and Lead Free
- Metal enclosure, for lower EMI

Absolute Maximum Ratings*

Parameter	Symbol	Minimum	Maximum	Unit	Note
Maximum Supply Voltage	V _{CC}	-0.5	4.0	V	-
Case Operating Temperature	T _A	-5	85	°C	-
Storage Temperature	T _S	-40	85	°C	-
Relative Humidity (Non-Condensing)	RH	0	85	%	-

*Exceeding the limits listed in the table may damage the transceiver module permanently

General Specifications

Parameter	Symbol	Minimum	Maximum	Unit	Note
Data Rate	BR	2.125	8.5	Gbps	1
Bit Error Rate	BER	-	10 ⁻¹²	-	2
Max. Supported Link Length on 9/125 µm SMF, 2.125, 4.25, 8.5 Gbps	L _{MAX1}	-	10	km	3

- Notes:**
1. 2x/4x/8x Fibre Channel compliant.
 2. Tested with a PRBS 2⁷-1 test pattern.
 3. Distances are based on IEEE 802.3 standards and FC-PI-4 Rev. 7.00 ("Fibre Channel Physical Interface-4 Specification". American National Standard for Information Systems, September 20, 2007.)

Datasheet

Electrical Specifications					
Parameter	Symbol	Minimum	Maximum	Unit	Note
Supply Voltage	V_{CC}	3.00	3.60	V	1
Supply Current	I_{CC}	-	300	mA	1
Transmitter					
Input Differential Impedance	R_{in}	80	120	Ω	2
Single Ended Data Input Swing	$V_{in, pp}$	90	350	mV	-
Transmit Disable Voltage	V_D	2	V_{CC}	V	-
Transmit Enable Voltage	V_{EN}	V_{ee}	$V_{ee} + 0.8$	V	3
Receiver					
Single Ended Data Output Swing	$V_{out, pp}$	150	425	mV	4
Data Output Rise/Fall Time @ 2.125 Gbps, 4.25 Gbps	t_r, t_f	-	120	ps	5
Data Output Rise/Fall Time @ 8.5 Gbps	t_r, t_f	-	60	ps	5
LOS Fault	$V_{LOS\ fault}$	2	$V_{CC\ HOST}$	V	6
LOS Normal	$V_{LOS\ norm}$	V_{ee}	$V_{ee} + 0.8$	V	6
Power Supply Rejection	PSR	100	-	mVpp	7
Deterministic Jitter Contribution < 4.25 Gbps	$RX\ \Delta\ DJ$	-	51.7	ps	8,9
Total Jitter Contribution < 4.25 Gbps	$RX\ \Delta\ TJ$	-	122.4	ps	9
Deterministic Jitter Contribution = 4.25 Gbps	$RX\ \Delta\ DJ$	-	25.9	ps	8,9
Total Jitter Contribution = 4.25 Gbps	$RX\ \Delta\ TJ$	-	61.2	ps	9

- Notes:**
1. Module power consumption never exceeds 1W.
 2. AC coupled.
 3. Or open circuit.
 4. Into 100 ohm differential termination.
 5. 20 – 80 %.
 6. LOS is LVTTTL. Logic 0 indicates normal operation; logic 1 indicates no signal detected.
 7. All transceiver specifications are compliant with a power supply sinusoidal modulation of 20 Hz to 1.5 MHz up to specified value applied through the power supply filtering network shown on page 23 of the Small Form-factor Pluggable (SFP) Transceiver MultiSource Agreement (MSA) 6, September 14, 2000. The Power Supply Rejection applies for a supply voltage range of 3.1 to 3.6 V.
 8. Measured with DJ-free data input signal. In actual application, output DJ will be the sum of input DJ and $\Delta\ DJ$.
 9. For 8.5 Gbps operation, Jitter values for gamma T and gamma R are controlled by TDP and stressed receiver sensitivity.

Datasheet

Optical Specifications					
Parameter	Symbol	Minimum	Maximum	Unit	Note
Transmitter					
Output Optical Power @ 8.5 Gbps	$P_{O, RH}$	-8.4	0.5	dBm	1
Output Optical Power @ 2.125, 4.25 Gbps	$P_{O, RL}$	-8.4	-3	dBm	2
Optical Wavelength	λ	1285	1345	nm	3
Spectral Width	σ	-	1	nm	3
Optical Modulation Amplitude	OMA	-5.4	-	dBm	3,4
Transmitter and Dispersion Penalty @ 8.5 Gbps	TDP	-	3.2	dB	5
Optical Rise/Fall Time @ 2.125, 4.25 Gbps	t_r/t_f	-	90	ps	6
Relative Intensity Noise	RIN	-	-128	dB/Hz	-
Receiver					
Unstressed Receiver OMA Sensitivity @ 8.5 Gbps	R_{SENSr}	-	-13.8	dBm	7
Unstressed Receiver OMA Sensitivity @ 4.25 Gbps	R_{SENS4}	-	-15.4	dBm	7
Unstressed Receiver OMA Sensitivity @ 2.125 Gbps	R_{SENS2}	-	-18.2	dBm	7
Maximum Average Receiver Power	RX_{MAX}	0.5	-	dBm	-
Optical Center Wavelength	λ_C	1260	1360	nm	-
Optical Return Loss	-	12	-	dB	-
LOS De-Assert	LOS_D	-	-19	dBm	-
LOS Assert	LOS_A	-30	-	dBm	-
LOS Hysteresis	-	0.5	-	dB	-

- Notes:**
1. High Bandwidth Mode. Class 1 Laser Safety per FDA/CDRH and EN (IEC) 60825 regulations.
 2. Low Bandwidth Mode. Class 1 Laser Safety per FDA/CDRH and EN (IEC) 60825 regulations.
 3. Also specified to meet curves in FC-PI-4 Rev 7.00 ("Fibre Channel Physical Interface-4 Specification". American National Standard for Information Systems, September 20, 2007) Figures 21, 22, and 23, which allow trade-off between wavelength, spectral width and OMA.
 4. Equivalent extinction ratio specification for Fibre Channel. Allows smaller ER at higher average power.
 5. For 8.5 Gb/s operation, Jitter values for gamma T and gamma R are controlled by TDP and stressed receiver sensitivity.
 6. Unfiltered, 20-80%. Complies with IEEE 802.3 (Gig. E), FC 1x and 2x eye masks when filtered.
 7. Measured with conformance signals defined in FC-PI-4 Rev. 10.0 specifications. Value in OMA. Measured with PRBS 2⁷-1 at 10⁻¹² BER.

Datasheet

Pin Descriptions

Pin	Function	Name/Description	Note
1	V _{EET}	Transmitter Ground (Common with Receiver Ground)	1
2	T _{FAULT}	Transmitter Fault.	2
3	T _{DIS}	Transmitter Disable. Laser Output Disabled on High or Open.	3
4	SDA	2-wire Serial Interface Data Line (MOD-DEF2)	4
5	SCA	2-wire Serial Interface Clock (MOD-DEF1)	4
6	MOD_ABS	Module Absent, connected to V _{EET} or V _{EER}	4
7	RS0	Rx Rate Select: Open or Low = 2.125 or 4.25 Gbps Fibre Channel (Low Bandwidth) High = 8.5 Gbps Fibre Channel (High Bandwidth)	5
8	LOS	Loss of Signal Indication. Logic 0 Indicates Normal Operation.	6
9	RS1	Tx Rate Select: Open or Low = 2.125 or 4.25 Gbps Fibre Channel (Low Bandwidth) High = 8.5 Gbps Fibre Channel (High Bandwidth)	5
10	V _{EER}	Receiver Ground (Common with Transmitter Ground)	1
11	V _{EER}	Receiver Ground (Common with Transmitter Ground)	1
12	RD-	Receiver Inverted DATA Out. AC Coupled.	-
13	RD+	Receiver Non-Inverted DATA Out. AC Coupled.	-
14	V _{EER}	Receiver Ground (Common with Transmitter Ground)	1
15	V _{CCR}	Receiver Power Supply	-
16	V _{CCT}	Transmitter Power Supply	-
17	V _{EET}	Transmitter Ground (Common with Receiver Ground)	1
18	TD+	Transmitter Non-Inverted DATA In. AC Coupled.	-
19	TD-	Transmitter Inverted DATA In. AC Coupled.	-
20	V _{EET}	Transmitter Ground (Common with Receiver Ground)	1

Notes:

1. Circuit ground is internally isolated from chassis ground.
2. T_{FAULT} is an open collector/drain output, which should be pulled up with a 4.7 k – 10 kohms resistor on the host board if intended for use. Pull up voltage should be between 2.0 V to V_{cc} + 0.3 V. A high output indicates a transmitter fault caused by either the TX bias current or the TX output power exceeding the preset alarm thresholds. A low output indicates normal operation. In the low state, the output is pulled to < 0.8 V.
3. Laser output disabled on T_{DIS} > 2.0 V or open, enabled on T_{DIS} < 0.8 V.
4. Should be pulled up with 4.7 k – 10 kohms on host board to a voltage between 2.0 V and 3.6 V. MOD_ABS pulls line low to indicate module is plugged in.
5. Rate select can also be set through the 2-wire bus in accordance with SFF-8472 v. 10.1. Rx Rate Select is set at Bit 3, Byte 110, Address A2h. Tx Rate Select is set at Bit 3, Byte 118, Address A2h. Note: writing a “1” selects maximum bandwidth operation. Rate select is the logic OR of the input state of Rate Select Pin and 2-wire bus.
6. LOS is open collector output. Should be pulled up with 4.7 k – 10 kohms on host board to a voltage between 2.0 V and 3.6 V. Logic 0 indicates normal operation; logic 1 indicates loss of signal.

Datasheet

Diagram of Host Board Connector Block Pin Numbers and Names

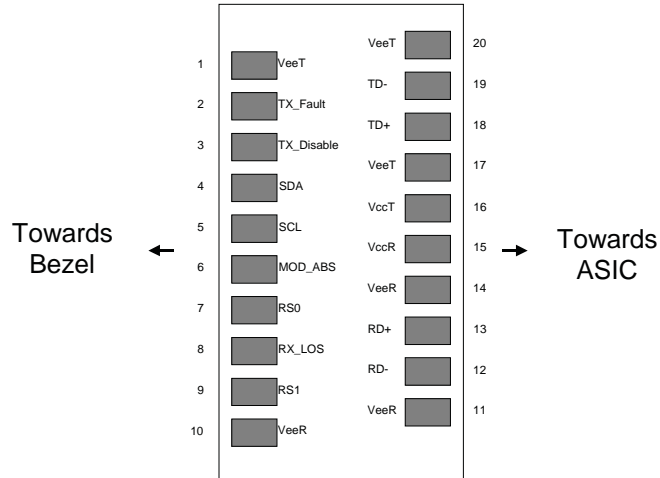

Mechanical Dimensions

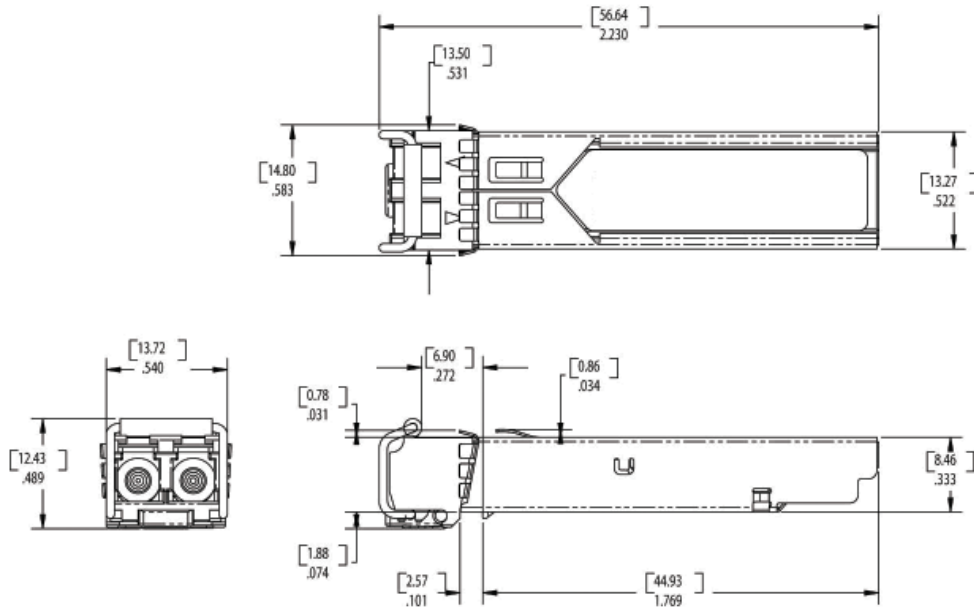

**Datasheet****Ordering Information**

Model	Description	Data Rate (Mbps)	Wavelength (nm)	Connector	Bail Latch Color	Max. Link Length (km)
SFP-8GD-LR	SFP+, 2.125 / 4.25 / 8.5 Gb/s, SM, with Digital Diagnostics.	2125 - 8500	1310	Duplex LC	Blue	0-10

Regulatory and Industry Compliances

Class 1 Laser Product, Complies with 21CFR 1040.10, 1040.11 and EN 60825-1

Certified by one or more of the following agencies: TÜV, UL, CSA

RoHS Directive; China RoHS; California RoHS Law, REACH Directive SVHC

Please visit <http://www.mrv.com> or contact a sales representative for more information and for ordering.

MRV has more than 50 offices throughout the world. Addresses, phone numbers and fax numbers are listed at www.mrv.com. Please e-mail us at sales@mrv.com or call us for assistance.

MRV Los Angeles
20415 Nordhoff St.
Chatsworth, CA 91311
800-338-5316
818-773-0900

MRV Boston
295 Foster St.
Littleton, MA 01460
800-338-5316
978-952-4700

MRV International
Business Park Moerfelden
Waldeckerstrasse 13
64546 Moerfelden-Walldorf
Germany
Tel. (49) 6105/2070
Fax (49) 6105/207-100

All statements, technical information and recommendations related to the products herein are based upon information believed to be reliable or accurate. However, the accuracy or completeness thereof is not guaranteed, and no responsibility is assumed for any inaccuracies. Please contact MRV Communications for more information. MRV Communications and the MRV Communications logo are trademarks of MRV Communications, Inc. Other trademarks are the property of their respective holders.