

## TDA 5660 P Modulator for TV, Video and Sound Signals

The monolithically integrated circuit TDA 5660 P is especially suitable as modulator for the 48 to 860 MHz frequency range and is applied e.g. in video recorders, cable converters, TV converter installations, demodulators, video generators, video security systems, amateur TV applications, as well as personal computers.

- Synchronizing level-clamping circuit
- Peak white value gain control
- Continuous adjustment of modulation index for positive and negative modulation
- Dynamic residual carrier setting
- FM sound modulator
- AM sound modulator
- Picture carrier to sound carrier adjustment
- Symmetrical mixer output
- Symmetrical oscillator with own RF ground
- Low radiation
- Superior frequency stability of main oscillator
- Superior frequency stability of sound oscillator
- Internal reference voltage

### Circuit description

Via pin 1, the sound signal is capacitively coupled to the AF input for the FM modulation of the oscillator. An external circuitry sets the preemphasis. This signal is forwarded to a mixer which is influenced by the AM modulation input of pin 16. The picture to sound carrier ratio can be changed by connecting an external voltage to pin 16, which deviates from the internal reference voltage. In case, the sound carrier should not be FM but AM modulated, pin 1 should be connected to pin 2, while the AF signal is capacitively coupled to pin 16. Through an additional external dc voltage at pin 16, the set AM modulation index can be changed by overriding the internally adjusted control voltage for a fixed AM modulation index. At the output of the above described mixer the FM and/or AM modulated sound signal is added to the video signal and mixed with the oscillator signal in the RF mixer. A parallel resonant circuit is connected to the sound carrier oscillator at pin 17, 18. The unloaded  $Q$  of the resonant circuit must be  $Q = 25$  and the parallel resistor  $R_T = 6.8 \text{ k}\Omega$  to ensure a picture to sound carrier ratio of 12.5 dB. At the same time, the capacitative and/or inductive reactance for the resonance frequency should have a value of  $X_C \approx X_L \approx 800 \Omega$ .

The video signal with the negative synchronous level is capacitively connected to pin 10. The internal clamping circuit is referenced to the synchronizing level. Should the video signal change by 6 dB, this change will be compensated by the resonant circuit which is set to the peak white value. At pin 11, the current pulses of the peak white detector are filtered through the capacitor which also determines the control time constant. When pin 12 is connected to ground, the RF carrier switches from negative to positive video modulation.

With the variable resistor of  $R = \infty \dots 0 \Omega$  at pin 12, the modulation depth, beginning with  $R = \infty$  and a negative modulation of  $m_{D/N} = 80\%$ , can be increased to  $m_{D/N} = 100\%$  and continued with a positive modulation of  $m_{D/P} = 100\%$  down to  $m_{D/P} = 88\%$  with  $R = 0 \Omega$ . The internal reference voltage has to be capacitively blocked at pin 2.

The amplifier of the RF oscillator is available at pins 3-7. The oscillator operates as a symmetrical ECO circuit. The capacitive reactance for the resonance frequency should be  $X_C \approx 70 \Omega$  between pins 3, 4 and 6, 7 and  $X_C \approx 26 \Omega$  between pins 4, 6. In order to set the required residual carrier suppression, pin 9 is used to compensate for any dynamic asymmetry of the RF mixer during high frequencies of  $> 300$  MHz. The oscillator chip ground, pin 5, should be connected to ground at the oscillator resonant circuit shielding. Via pin 3 and 7 an external oscillator signal can be injected inductively or capacitively. The peripheral layout of the pc board should be provided with a minimum shielding attenuation of approx. 80 dB between the oscillator pins 3-7 and the modulator outputs 13-15.

For optimum residual carrier suppression, the symmetric mixer outputs at pins 13, 15 should be connected to a matched balanced-to-unbalanced broadband transformer with excellent phase precision at 0 and 180 degrees, e.g. a Guanella transformer. The transmission loss should be less than 3 dB. In addition, an LC low pass filter combination is required at the output. The cut-off frequency of the low pass filter combination must exceed the maximum operating frequency.

If the application circuit according to figure 1, 2 is used, a multiplication factor  $V/RF$  (application) =  $V/RF$  (data sheet) 3.9 must be used to convert a  $300 \Omega$  symmetrical impedance to an asymmetrical impedance of  $75 \Omega$  for the stated RF output voltage  $V_a$  of the type specification in order to ensure a transmission attenuation of 0 dB for the balanced-to-unbalanced mixer.

**Maximum ratings**

		min	max		Remarks
Supply voltage	$V_S$	-0.3	14.5	V	
Current from pin 2	$-I_2$	0	2	mA	$V_2 = 7$ to 8 V $V_S = 9.5$ to 13.5 V
Voltage at pin 1	$V_1$	$V_2 - 2$	$V_2 + 2$	V	$V_S = 9.5$ to 13.5 V
Voltage at pin 9	$V_9$	-4	1	V	
Voltage at pin 10	$V_{10\text{pp}}$		1.5	V	only via C (max. 1 $\mu\text{F}$ )
Capacitance at pin 2	$C_2$	0	100	nF	
Capacitance at pin 11	$C_{11}$	0	15	$\mu\text{F}$	
Voltage at pin 12	$V_{12}$	-0.3	1.4	V	
Voltage at pin 13	$V_{13}$	$V_2$	$V_S$	V	
Voltage at pin 15	$V_{15}$	$V_2$	$V_S$	V	
Voltage at pin 16	$V_{16}$	$V_2 - 1.5$	$V_2 + 1.5$	V	$V_S = 9.5$ to 13.5 V
Only the external circuitry shown in application circuits 1 and 2 may be connected to pins 3, 4, 6, 7, 17 and 18					
Junction temperature	$T_j$		150	$^{\circ}\text{C}$	
Storage temperature	$T_{\text{stg}}$	-40	125	$^{\circ}\text{C}$	
Thermal resistance (system-air)	$R_{\text{th SA}}$		80	K/W	

**Operating range**

Supply voltage	$V_S$	9.5	13.5	V	
Video input frequency	$f_{\text{VIDEO}}$	0	5	MHz	
Sound input frequency	$f_{\text{AF}}$	0	20	kHz	
Output frequency	$f_q$	48	860	MHz	depending on the oscillator circuitry at pins 3-7
Ambient temperature	$T_A$	0	70	$^{\circ}\text{C}$	
Sound oscillator	$f_{\text{OSC}}$	4	7	MHz	
Voltage at pin 13, 15	$V_{13,15}$	$V_2$	$V_S$	V	

7

## Characteristics

 $V_S = 11\text{ V}; T_A = 25^\circ\text{C}$ 

		Test conditions	Figure	min	typ	max	
Current consumption	$I_B$	$I_2 = 0\text{ mA}$	1; 2	22	30	40	mA
Reference voltage	$V_2$	$0 \leq I_2 \leq 1\text{ mA}$	1; 2	7	7.5	8	V
Oscillator frequency range	$f_{\text{OSC}}$	External circuitry adjusted to frequency		48		860	MHz
Turn-on start-up drift	$\Delta f_{\text{OSC}}$	TC value of capacitor in osc. circuit is 0; drift is referenced only to self-heating of the component $t = 0.5\text{--}10\text{ s};$ $T_A = \text{const.}$					
		Ch 30	1; 2	0	-50	-500	kHz
		Ch 40	1; 2	0	-200	-500	kHz
Frequency drift as function of $V_S$	$-\Delta f_{\text{OSC}}$	$V_S = 9.5\text{--}13.5\text{ V}$ $T_A = \text{const.}$	1; 2	0			kHz
		Ch 40		-150		150	kHz
Video input current at pin 10	$-I_{10}$	$C_{10} \leq 1\text{ }\mu\text{F}$	5	0		10	$\mu\text{A}$
Video input voltage at pin 10	$V_{10\text{pp}}$	at coupling capac. $C \leq 1\text{ }\mu\text{F}$ $I_{\text{leak}} \leq \pm 0.3\text{ }\mu\text{A}$	21; 22	0.7		1.4	V
Modulation depth	$m_{\text{D/N}}$	neg. mod.	1; 16	75	80	85	%
$V_{\text{VIDEOpp}} = 1\text{ V}; f_{\text{VIDEO}} = 200\text{ kHz}$ sine signal	$m_{\text{D/P}}$	pos. mod.	2; 16	83	88	93	%
Output impedance	$Z_{13}; Z_{15}$	static	24	10			k $\Omega$
RF output voltage	$V_{\text{q rms}}$	Ch 40	1b	2.5	3.5	5.5	mV
Modulation signal in neg. modulation pin 12 open							
Output capacitance	$C_{13} = C_{15}$		25	0.5	1	2.0	pF
S parameter at pins 3, 4 and 6, 7			26				
RF output phase	$\alpha_{13,15}$			140	180	220	degrees
RF output voltage change; adjustment range	$\Delta V_{\text{q}}$	$f = 543.25\text{--}623.25$ $\Delta f = 80\text{ MHz}$ Ch 30-Ch 40	1	0		1.5	dB
RF output voltage change	$\Delta V_{\text{q}}$	$f = 100\text{--}300\text{ MHz}$	6	0		1.5	dB
RF output voltage change	$\Delta V_{\text{q}}$	$f = 48\text{--}100\text{ MHz}$	6	0		1.5	dB
Oscillator interference FM caused by AM modulation and coupling of the modulator output with the oscillator resonant circuit;							
$V_{\text{VIDEOpp}} = 1\text{ V};$ $f_{\text{VIDEO}} = 10\text{ kHz};$ sine signal							
	Ch 30		1; 9	0	5	15	kHz
	Ch 40		1; 9	0	7	21	kHz

## Characteristics

 $V_S = 11 \text{ V}; T_A = 25^\circ \text{C}$ 

		Test conditions	Figure	min	typ	max	
Intermodulation ratio	$a_{MR}$	$f_P + 1.07 \text{ MHz}$	1; 7; 15	54	75		dB
Harmonic wave ratio	$a_H$	$f_P + 8.8 \text{ MHz}$ without video signal 19, 20, 21 unmodulated video and sound carrier, measured with the spectrum analyzer as difference between video carrier signal level and sideband signal level without video and sound modulation.	1; 7; 15	35			dB
Harmonic wave ratio	$a_H$	$f_P + 2f_S$	1; 7	35	48		dB
Harmonic wave ratio	$a_H$	$f_P + 3f_S$ $V_Q$ with spectrum analyzer; loaded Q factor $Q_L$ of the sound oscillator resonant circuit adjusted by $R_S$ to provide the required picture to sound carrier ratio of 12.5 dB; $R_S = 6.8 \text{ k}\Omega$ ; $Q_U = 25$ of the sound oscillator circuit.	1; 7	42	48		dB
Sound carrier ratio	$a_{P/S}$		1; 7; 17	10	12.5	15	dB
Color picture to sound carrier ratio	$a_P$	$f_P + 4.4 \text{ MHz}$ (dependent on video signal)	1		17		dB
All remaining harmonic waves	$a$	Multiple of fundamental wave of picture carrier, without video signal, measured with spectrum analyzer;	1	15			dB
Amplitude response of the video signal	$a_V$	$f_{P/S} = 523.25\text{-}623.25 \text{ MHz}$ $V_{\text{VIDEO PP}} = 1 \text{ V}$ with additional modulation $f = 15 \text{ kHz-}5 \text{ MHz}$ sine signal between black and white	1; 13	0		1.5	dB
Residual carrier suppression	$a_R$	With adjustment at pin 9 Ch 30...Ch 40	1; 12	32			
Static mixer balance characteristic	$\Delta V_{13/15}$	$V_9$ adjusted to $\Delta V_{13/15}$ minimum	21; 23	-100	0	+100	mV
Dynamic mixer balance characteristics	$V_{13 \text{ rms}}$	$V_9$ adjusted to $V_{13 \text{ rms}}$ minimum	21; 23		0	10	mV
Stability of set modulation depth	$\Delta m_D$	Video input voltage changes with sine signals $f = 0.2 \text{ MHz}$ ; $\Delta V_{\text{VIDEO PP}} = 1 \text{ V}$ $\pm 3 \text{ dB}$ ; Ch 30...Ch 40; $V_S = 12 \text{ V}$ ; $T_A = \text{const.}$			1	$\pm 2.5$	%
Stability of set modulation depth	$\Delta m_D$	$f = 48\text{...}100 \text{ MHz}$	6		1	$\pm 2.5$	%
Stability of set modulation depth	$\Delta m_D$	$f = 100\text{...}300 \text{ MHz}$	6		2	$\pm 4$	%
Stability of set modulation depth	$\Delta m_D$	$T_A = 0\text{-}60^\circ \text{C}$ ; $V_S = 12 \text{ V}$	1		1	$\pm 2.5$	%

**Characteristics** $V_S = 11\text{ V}; T_A = 25\text{ }^\circ\text{C}$ 

	Test conditions	Figure	min	typ	max	
Stability of set modulation depth	$V_S = 9.5\text{-}13; 5\text{ V};$ $T_A = \text{const.}$	1		1	$\pm 2.5$	%
Interference product ratio sound in video; sound carrier FM mod.	Ch 30...Ch 40	1; 11	48	60		dB
Signal-to-noise ratio in video; sound carrier unmodulated	Ch 30...Ch 40	1; 11	48	74		dB
Interference product ratio sound in video sound carrier AM mod.	Ch 30...Ch 40	1; 11	20	33		dB
Unweighted FM noise level ratio video in sound; FuBK test picture as video signal	Ch 39	1a; 8	48	54		dB
Unweighted FM noise level ratio video in sound	Ch 39; test picture VU G-Y; U/V	2; 8	48	56		dB
	Ch 39; color bar	2; 8	46	52		dB
	Ch 39; uniform red level	2; 8	48	58		dB
	Ch 39; uniform white level	2; 8	45	51		dB
	Ch 39; test pattern	2; 8	48	55		dB
	Ch 39; white bar	2; 8	46	52		dB
	Ch 39; bar	2; 8	45	50.8		dB
	Ch 39; 20T/2T	2; 8	43	49		dB
	Ch 39; 30% white level	2; 8	48	58		dB
	Ch 39; 250 kHz	2; 8	46	52		dB
	Ch 39; multiburst	2; 8	46	53		dB
	Ch 39; ramp	2; 8	44	50		dB
Signal-to-noise ratio of sound oscillator		1a; 8	48	54		dB
Differential gain	measured with measurement demodulator, video test signals and vector scope	1			10	%
Differential phase		1			15	%
Period required for peak white detector to reach steady state for full modulation depth with 1 white pulse per half frame with control in steady state	C at pin 11 = 10 $\mu\text{F}$ ; $I_{\text{leak}} \leq 2\text{ } \mu\text{A}$	1		6	50	$\mu\text{s}$

**Characteristics** $V_S = 11 \text{ V}; T_A = 25^\circ \text{C}$ 

	Test conditions	Figure	min	typ	max	
Setting time for video signal change from 0 $V_{pp}$ to 1.4 $V_{pp}$	t	Video blanking signal content is uniform white level	1	120	500	$\mu\text{s}$
Setting time for video blanking signal from 100% white level to 42% grey level with subsequent rise in grey level to 71% of video blanking signal (due to decontrol process)	t		1	2.25	5	s
Sound oscillator frequency range	$f_{S/OSC}$	Unloaded Q factor of resonant circuit $Q_U = 25$ ; resonance frequency 5.66 MHz	1	4	7	MHz
Turn-on start-up drift	$\Delta f_{S/OSC}$	Capacitor TC value in sound oscillator circuit is 0, drift is based only on component heating. $T_A = \text{const};$ $f_{S/OSC} = 5.5 \text{ MHz}$	1	5	15	kHz
Sound oscillator frequency operating voltage	$\Delta f_{S/OSC}$	$V_S = 9.5\text{-}13.5 \text{ V};$ $f_{S/OSC} = 5.5 \text{ MHz};$ $T_A = \text{const}; Q_U = 25$	1	5	15	kHz
FM mod. harmonic distortion	$THD_{FM}$	$V_{1\text{rms}} = 150 \text{ mV}$	19; 19a	0.6	1.5	%
Audio preamplifier input impedance (dyn.); FM operation	$Z_1$		1	200		k $\Omega$
FM sound modulator, static modulation characteristic	$\Delta f_{S/OSC}$	$\Delta V_{1/2} = V_1 - V_2 = \pm 1 \text{ V};$ $f_{S/OSC} = 5.5 \text{ MHz};$ $Q_U = 25$	1; 14	$\pm 210$	$\pm 270$	$\pm 330$ kHz
FM sound modulation characteristic (dynamic)	$\Delta f_M / \Delta V_1$		1a; 10a	0.3	0.38	0.46 kHz/mV
AM sound modulation factor	m	$V_{AF} = 0.3 \text{ V}$	2; 3; 4a, b	30	40	50 %
AM sound modulation harmonic distortion	$THD_{AM}$	$m = 86\%;$ $V_{AF} = 0.64 \text{ V};$ $f_{AF} = 1 \text{ kHz}$	\	0.7	3	%
AM audio preamplifier input impedance	$Z_{16}$		2	25	50	75 k $\Omega$
AM sound modulator input voltage	$V_{AF}$	$m = 90\%;$ $f_{AF} = 1 \text{ kHz}$	2	0.5	0.67	0.84 V

**Pin description**

<b>Pin</b>	<b>Function</b>
1	AF input for FM modulation
2	Internal reference voltage
3	Symmetrical oscillator input
4	Symmetrical oscillator output
5	Oscillator ground
6	Symmetrical oscillator output
7	Symmetrical oscillator input
8	Supply voltage
9	Dynamic residual carrier adjustment
10	Video input with clamping
11	Connection for smoothing capacitor for video control loop
12	Switch for positive and negative modulation as well as residual carrier control
13	Symmetrical RF output
14	Remaining ground of component
15	Symmetrical RF output
16	Picture to sound carrier ratio (adjustment and AM sound input)
17	Sound oscillator symmetrical input for tank circuit
18	Sound oscillator symmetrical input for tank circuit



Block diagram

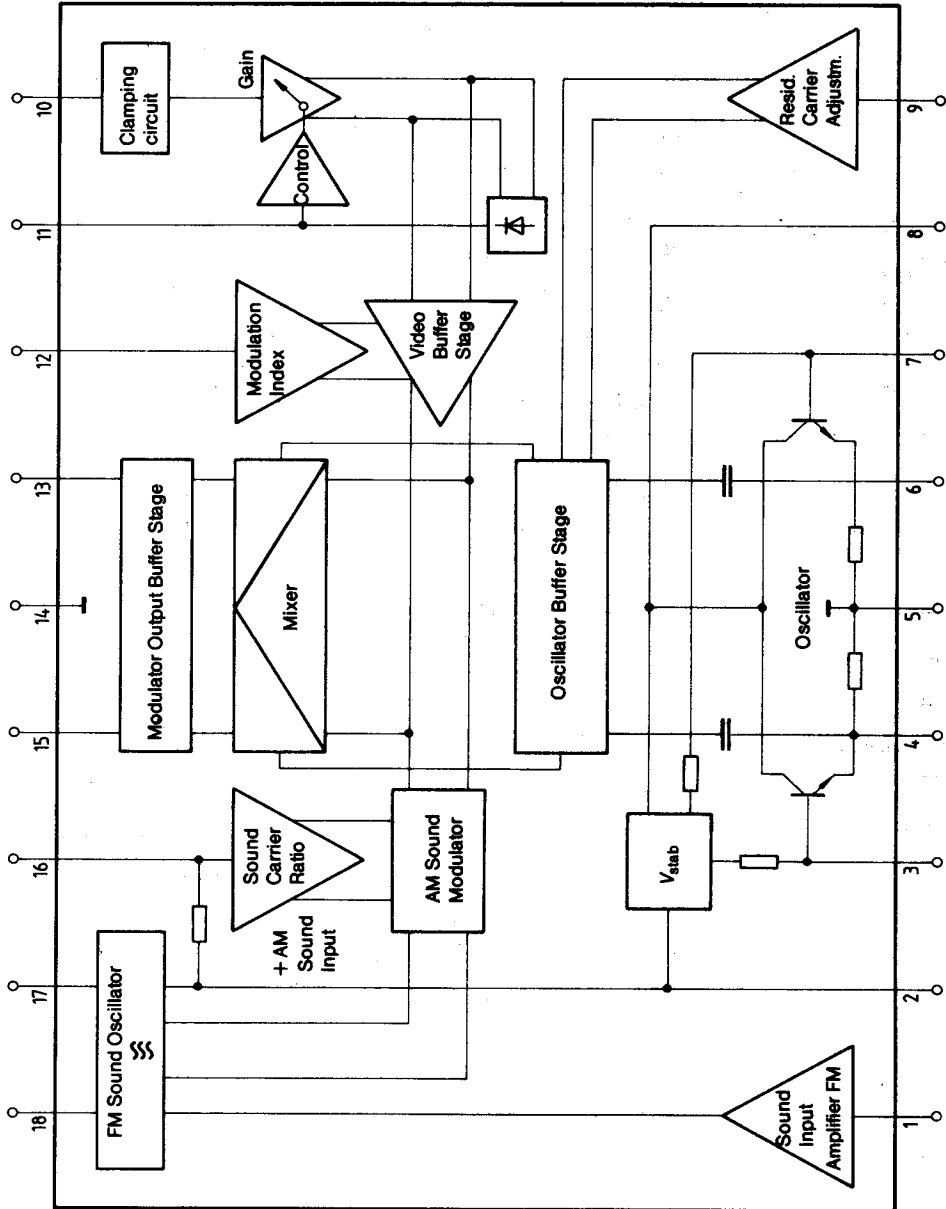

7

Test and measurement circuit 1 for FM sound carrier and negative video modulation

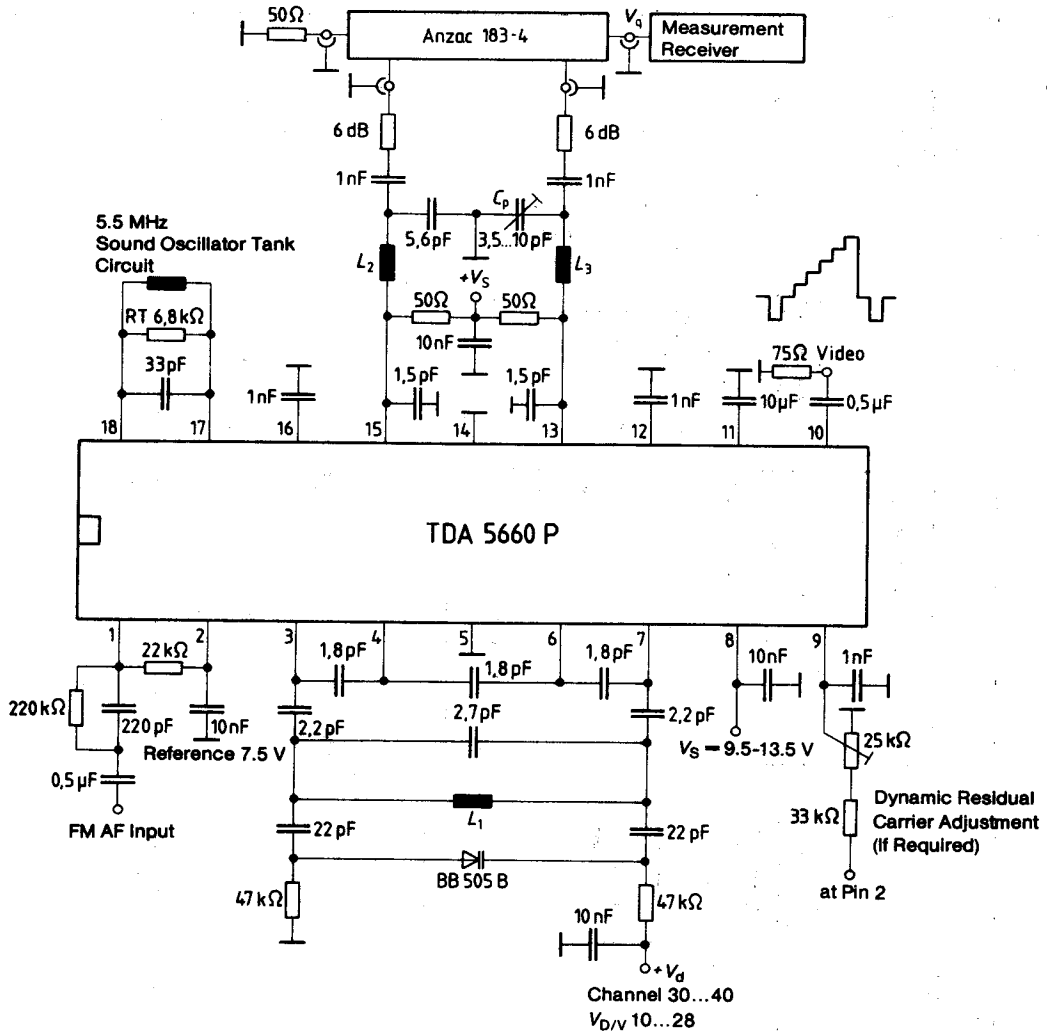

Figure 1

Test and measurement circuit 1 for FM sound carrier and negative video modulation

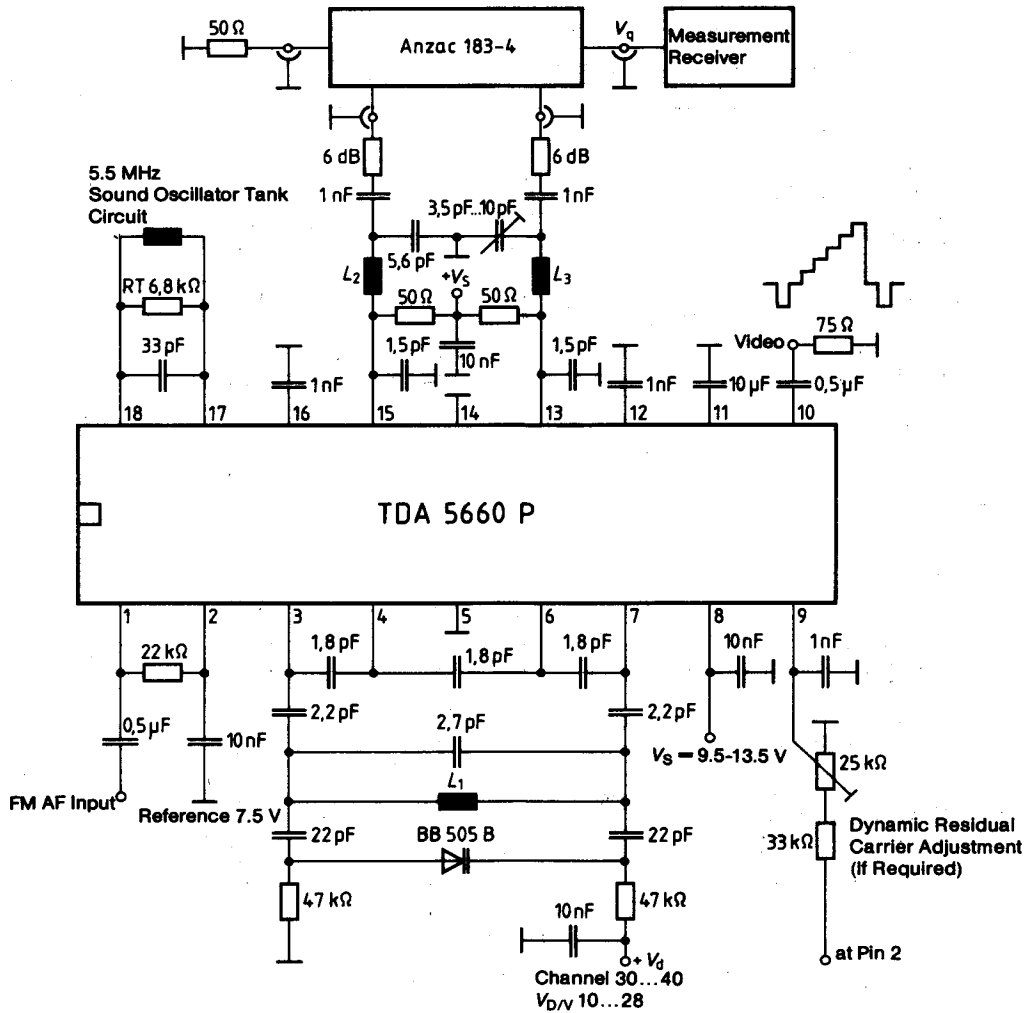

Figure 1a

7

Test and measurement circuit 1 for FM sound carrier and negative video modulation

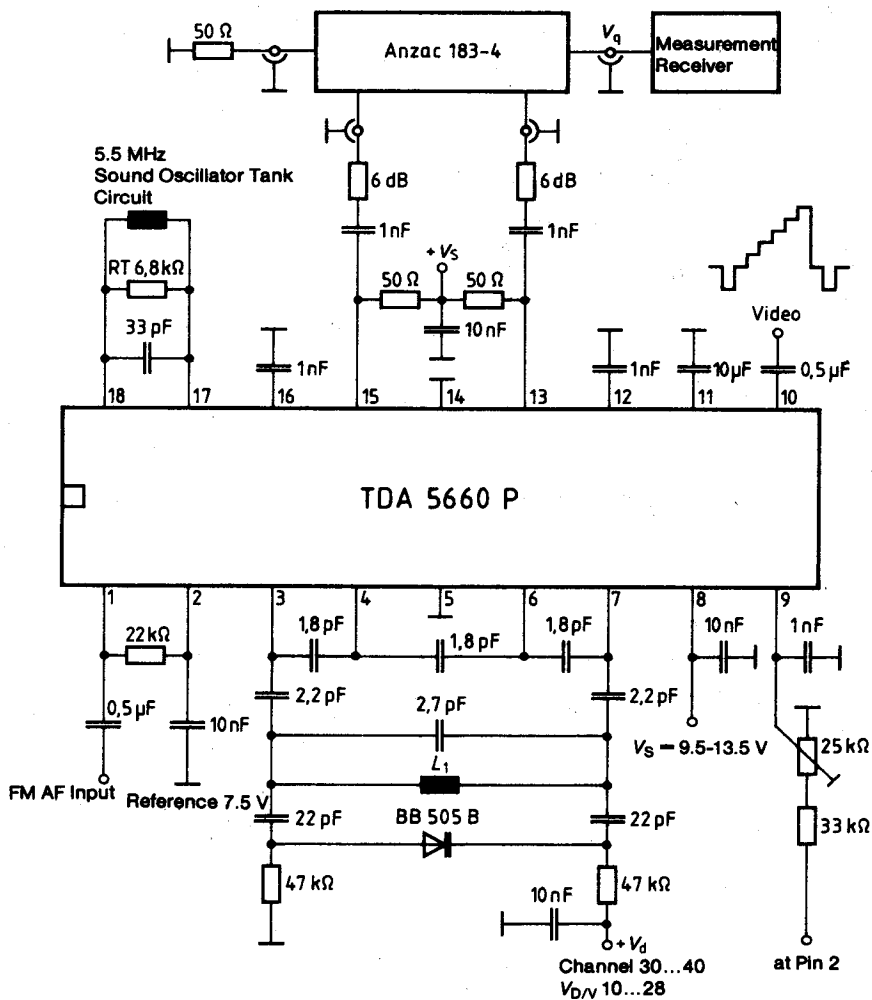

Figure 1b

Test and measurement circuit 2 for FM sound carrier and negative video modulation

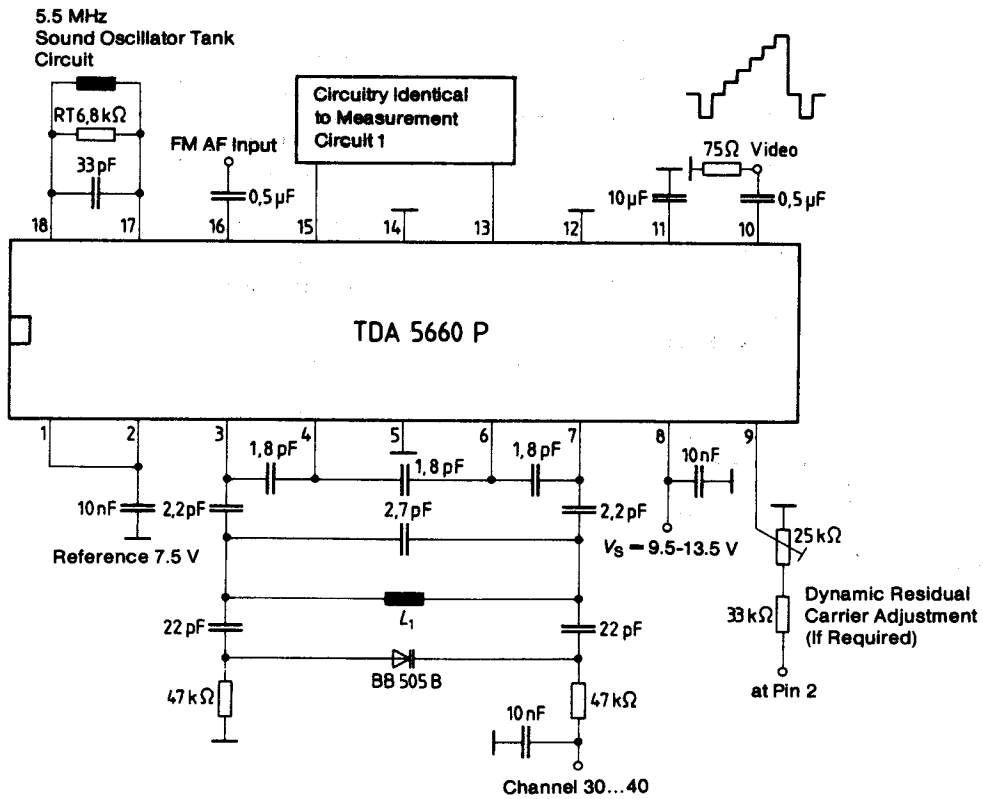

Figure 2

7

## AM sound modulation measurement

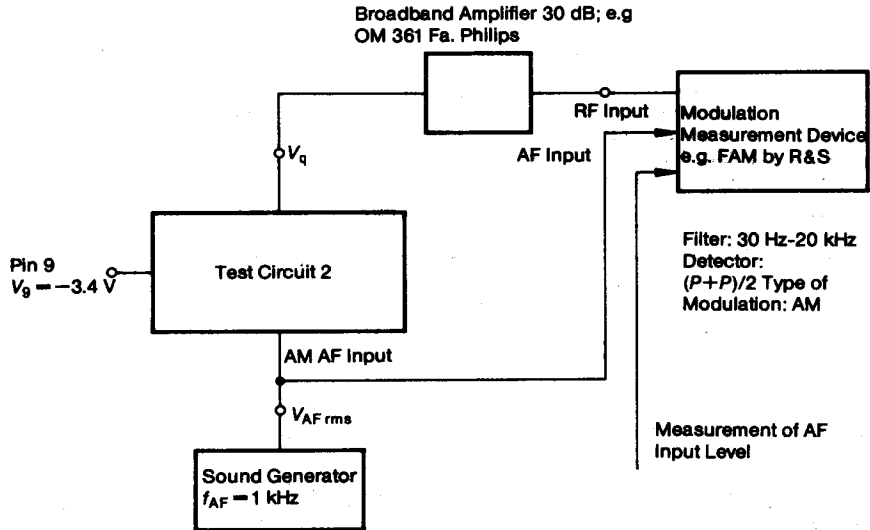
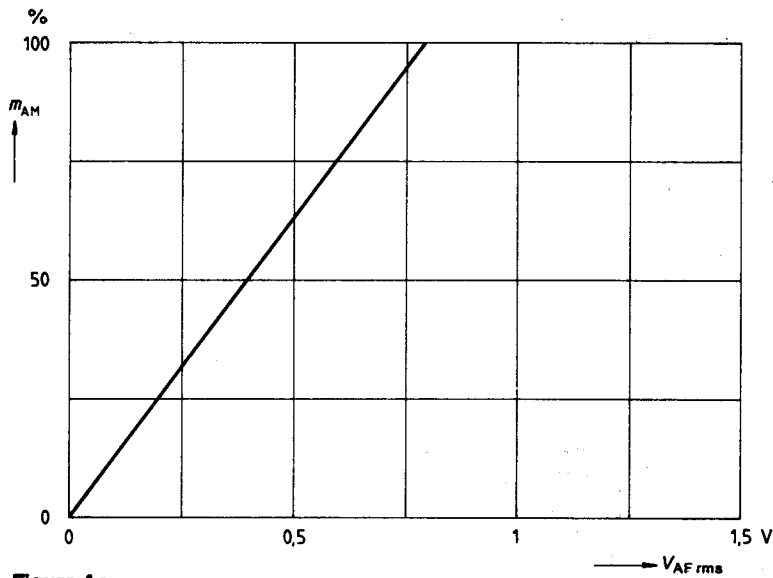

Figure 3

**AM sound carrier modulation index versus  
AF input voltage at pin 16**



**Figure 4 a**

**AM sound carrier modulation index versus  
dc voltage offset at pin 16**

$V_{AF\ rms} = 0.6\text{ V}; \Delta V_{16/2} (V) = V_2 - V_{16}$

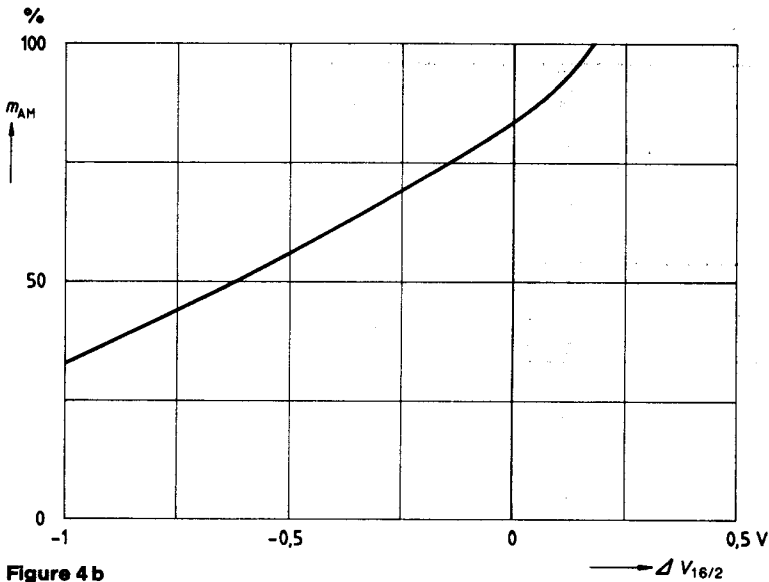

**Figure 4 b**

7

Measurement circuits

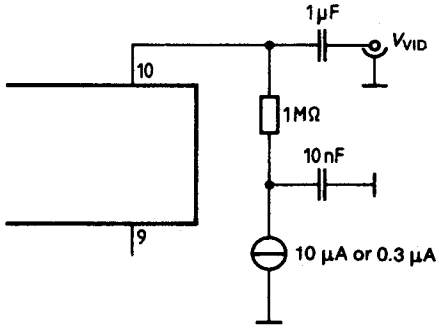
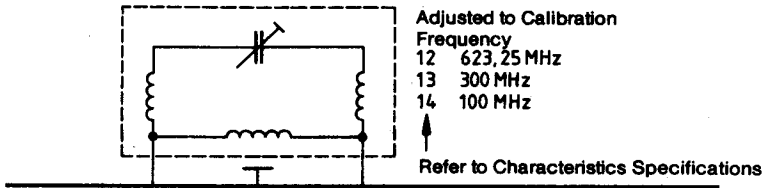

Figure 5



TDA 5660 P

Remaining External Circuitry as Fig. 1

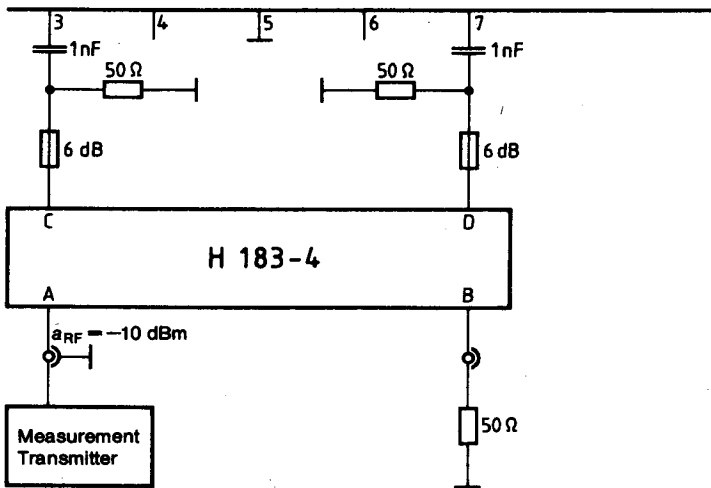

Figure 6

7-106



Frequency spectrum above the video carrier, measured at clamp  $V_o$  with a spectrum analyzer

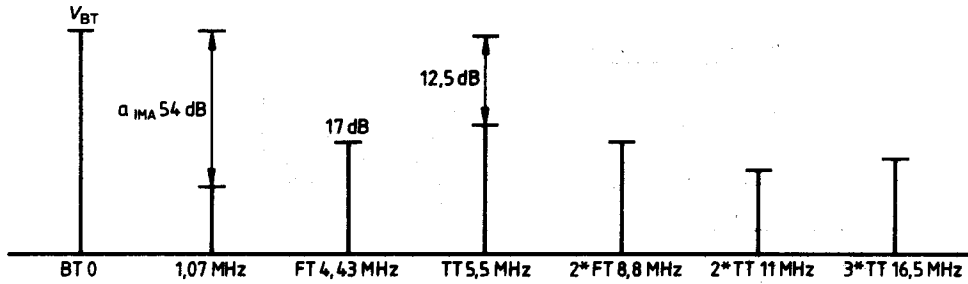
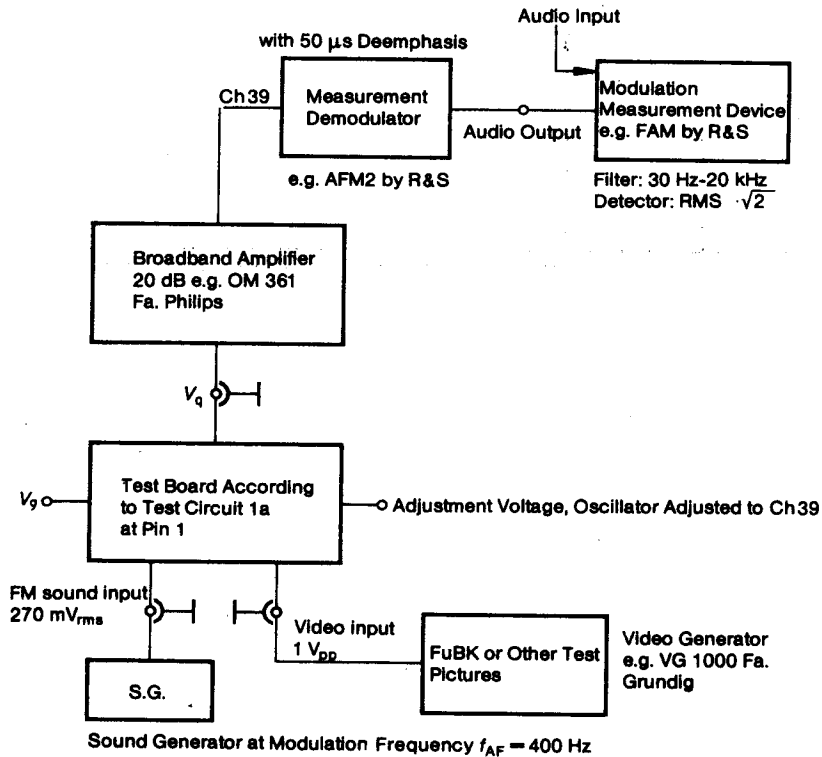

Figure 7

BT = Video Carrier  
 FT = Frequency Carrier  
 TT = Sound Carrier

**Description of the measurement configuration to measure the noise voltage, video in sound**



**Figure 8**

**Calibration:** A signal of  $V_{AF\ rms} = 270$  mV and  $f = 0.4$  kHz, corresponding to a nominal deviation of 30 kHz, is connected to the sound input, and the demodulated AF reference level at the audio measurement device is defined as 0 dB. No video signal is pending.

**Measurement:** 1) The AF signal is switched off and the FuBK video signal is connected to the video input with  $V_{VIDEO\ pp} = 1$  V. The audio level in relation to the reference calibration level is measured as ratio  $a_{p/s} = 20 \log (V_{FUBK}) / (V_{nominal})$ .  
2) AF and video signal are switched off. The noise ratio in relation to the AF reference calibration level is measured as signal-to-noise ratio  $a_{S/N}$ .

## Description of the measurement configuration to measure the oscillator interference FM

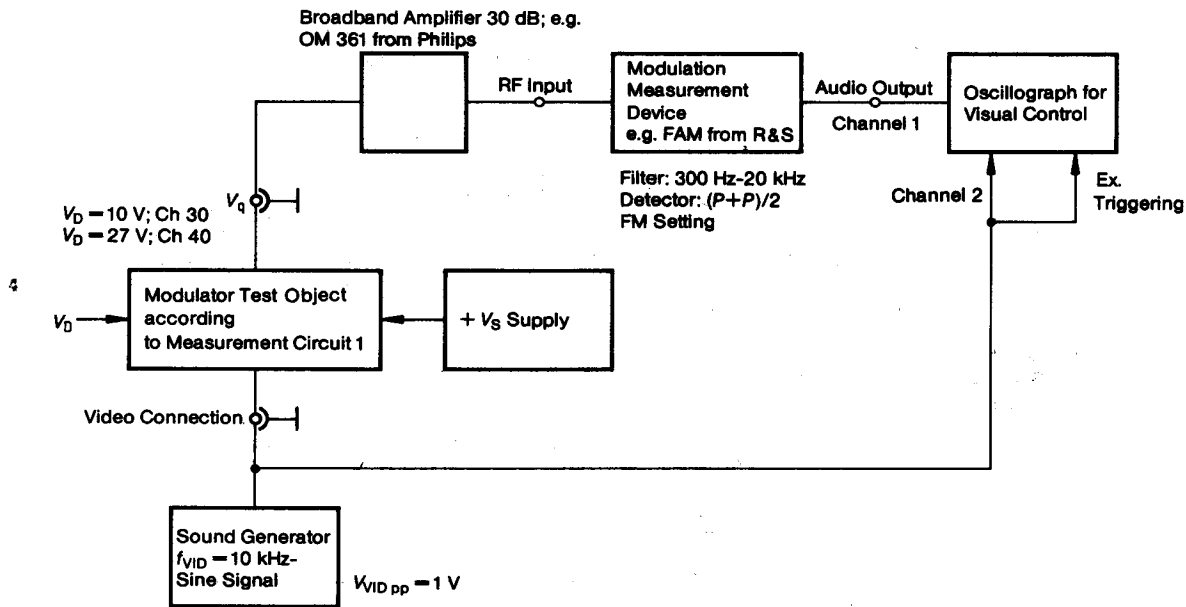

Figure 9

**Description of the measurement configuration to measure the total harmonic distortion during FM operation of the sound carrier**

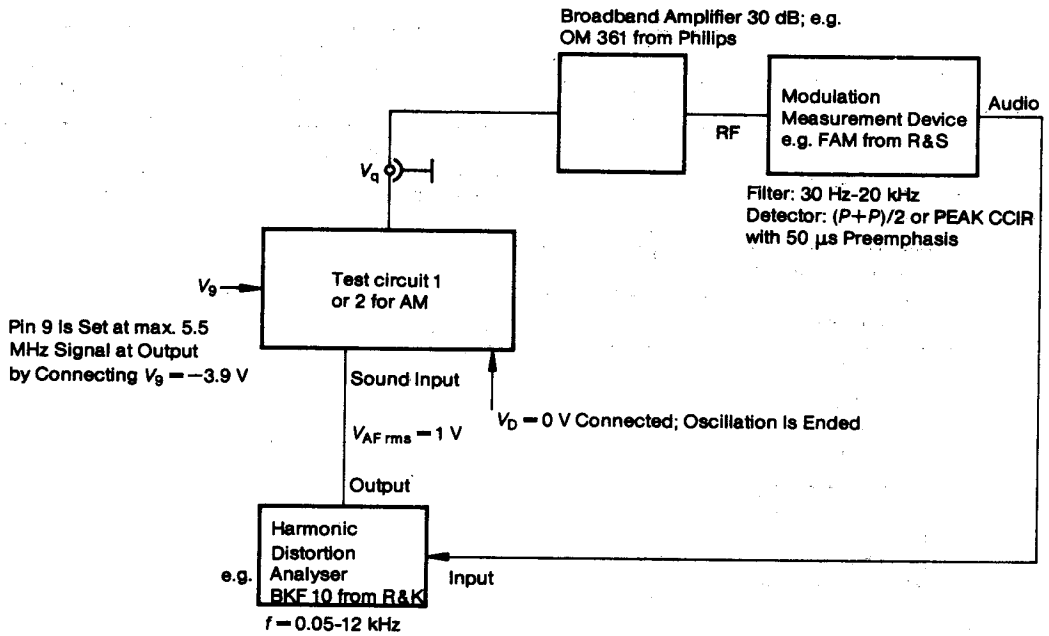

Figure 10

**Description of the measurement configuration to measure the total harmonic distortion during FM operation of the sound carrier**

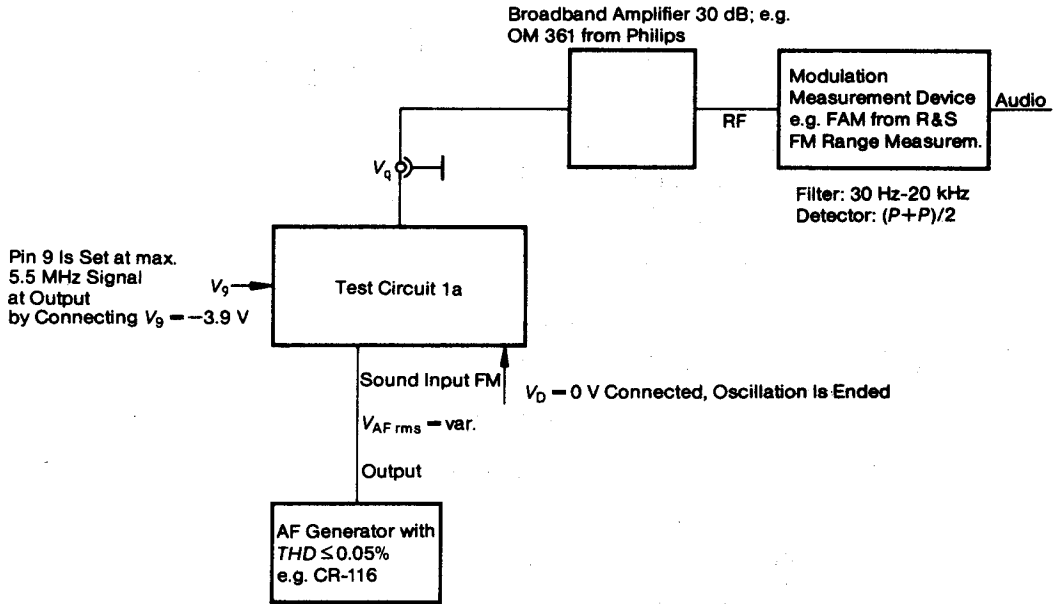
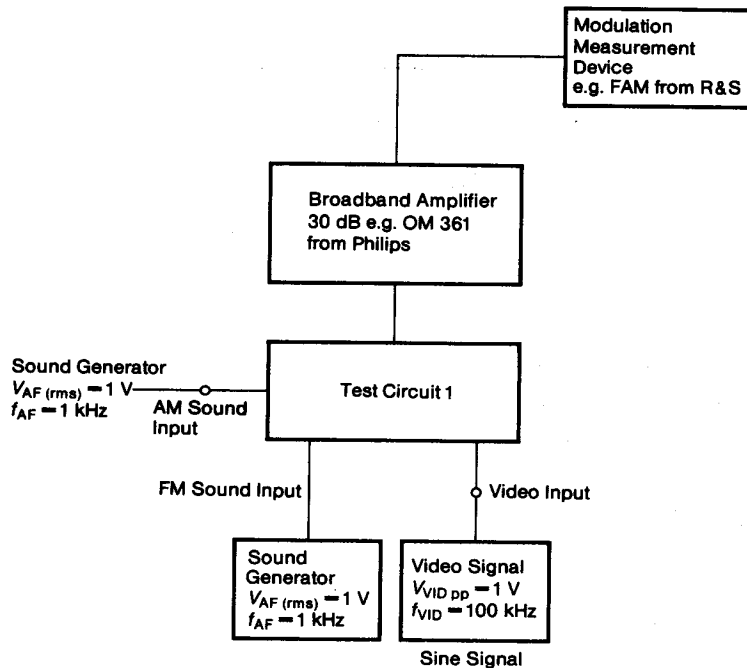

Figure 10 a

**Description of the measurement configuration to measure the sound and/or noise in video during FM and/or AM sound carrier modulation**

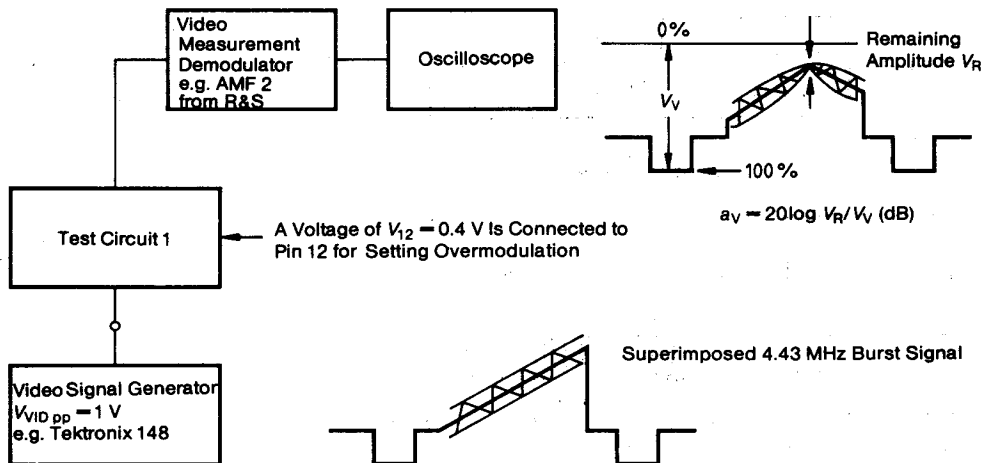

**Figure 11**

**Calibration:** AF signals are switched off; video signal is pending at the video input; device to measure modulation set at AM is adjusted to video carrier; filter: 300 Hz...200 kHz; detector  $(P+P)/2$ ; resulting modulation index is defined as  $m_V = 0$  dB.

- Measurement:**
- 1) Measurement of interference product ratio sound in video during FM modulation of the sound carrier: AF signal is connected to FM sound input; video signal is switched off; device to measure modulation is set to AM; filter: 300 Hz... 3 kHz; detector:  $(P+P)/2$ ; a ratio of  $a_{S/P} = 20 \log m_{V/S}/m_V$  is derived from the resulting modulation index  $m_{V/S}$ .
  - 2) Measurement of interference product ratio sound in video during AM modulation of sound carrier: AF signal is connected to AM sound input; otherwise identical with measurement 1.
  - 3) Measurement of signal-to-noise ratio in video without AM/FM modulation of sound carrier: AF signals are switched off; video signal is switched off; control voltage at pin 11 is clamped to value present during connected video signal; modulation device is set to AM; filter: 300 Hz... 3 kHz; detector: RMS  $\sqrt{2}$ ; readout in dB to reference level of calibration is  $a_{S/P}$ .

### Description of the measurement configuration to measure the residual carrier suppression



Adjust  $C_p$  in Circuit 1 and Dynamic Residual Carrier Suppression to Suppression Maximum.

**Figure 12**

**Description of the measurement configuration to measure the video amplitude response**

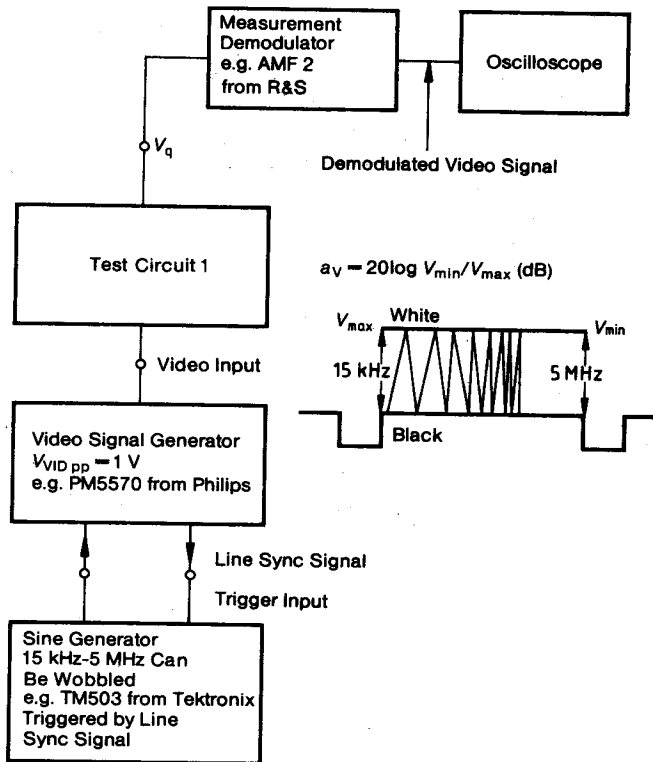

**Figure 13**



**Static modulation characteristic of the FM sound modulator**

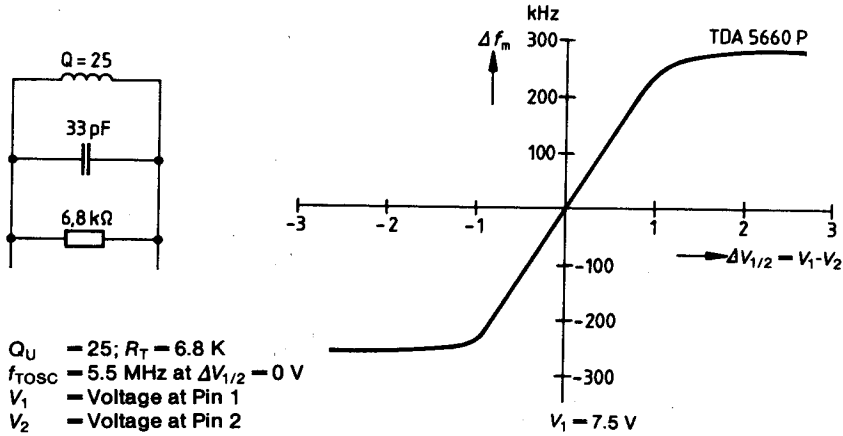

**Figure 14**

**Description of the measurement configuration to measure the 1.07 MHz moires**

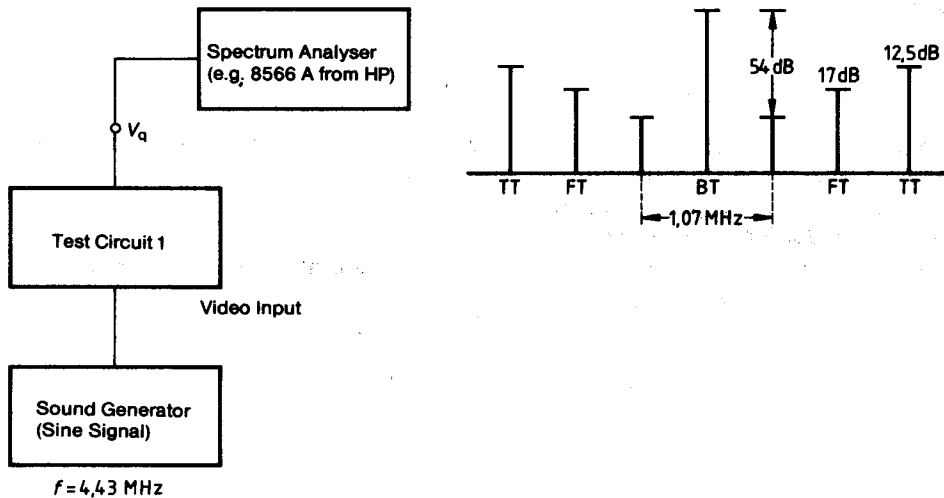

$V_{VID\ pp} = 250 \text{ mV}$ : Frequency carrier level lies below the activation point of the video amplitude control and has been set to provide a ratio of 17 dB with respect to the video carrier.

**Figure 15**

**Modulation index during negative video modulation and/or the voltage at pin 12 versus current at pin 12**

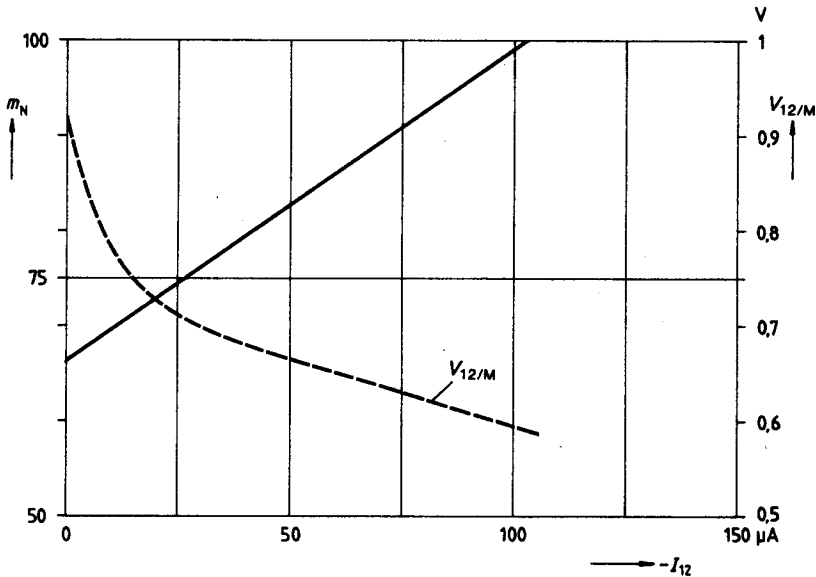

**Figure 16 a**

Modulation depth is calculated as  $m_p = (2 \times m)/(1 + m)$  from the modulation index. Prerequisite is a sine-shaped modulation.

$m_N$  = modulation index for negative modulation

$m_P$  = modulation index for positive modulation

If a resistor is connected to ground at pin 12 to adjust modulation depth, the resistor is calculated as  $R_{12/M} = (V_{12/M})/I_{12}$ .

**Modulation index during positive video modulation and/or the voltage at pin 12 versus current at pin 12**

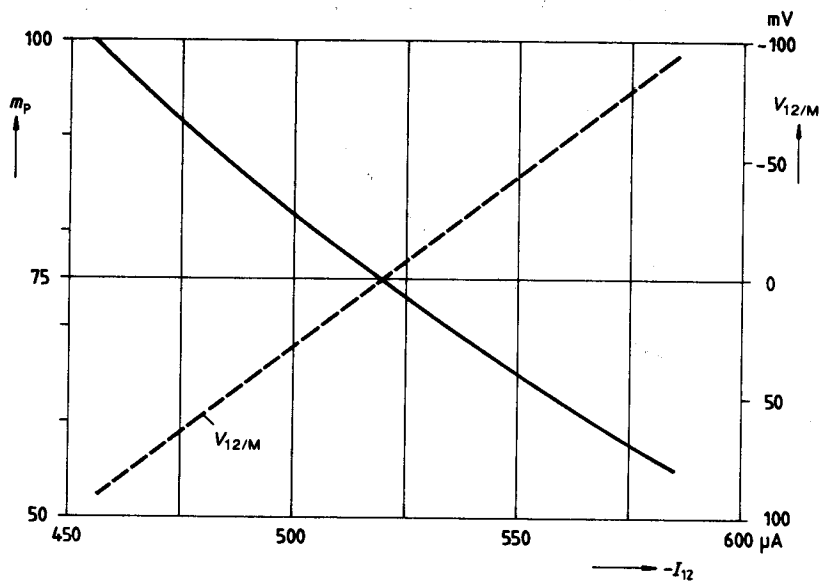

**Figure 16**

7

Modulation depth is calculated as  $m_D = (2 \times m)/(1 + m)$  from the modulation index. Prerequisite is a sine-shaped modulation.

$m_N$  = modulation index for negative modulation

$m_P$  = modulation index for positive modulation

If a resistor is connected to ground at pin 12 to adjust modulation depth, the resistor is calculated as  $R_{12/M} = (V_{12/M})/I_{12}$ .

**Picture to sound carrier ratio versus dc voltage offset at pin 16**

unloaded Q factor of resonant circuit  $Q_U = 25$ ,  $R_T = 6.8 \text{ k}$ ;  $f = 5.5 \text{ MHz}$ .

The picture to sound carrier ratio of  $a_{P/S} = 13 \text{ dB}$  was set via the loaded Q factor  $Q_L$  without external voltage at pin 16.

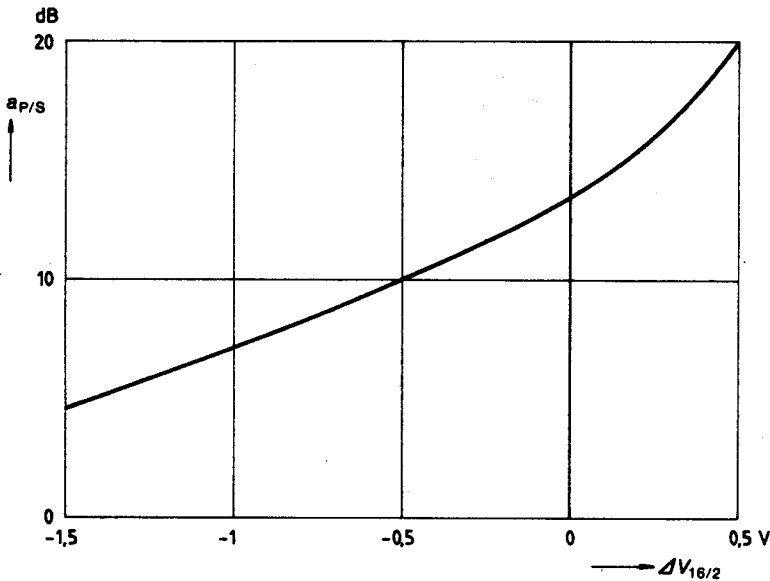

**Figure 17**

To adjust the picture to sound carrier ratio, a component was used with a resistance of typ.  $11.5 \text{ k}\Omega$  at pins 17, 18.

The loaded Q factor of the resonant circuit was derived from the internal resistance  $R_{17/18}$  connected in parallel with the external resistor  $R_s$ .

**Measurement of the sound oscillator FM deviation without preemphasis and deemphasis;**  
 $f_{AF} = 1$  kHz; modulation deviation, sensitivity  $(\Delta f_{AF})/(\Delta V_{AF}) = 0.38$  kHz/mV;  $V_{AF} = \text{var}$ ;  
 detector  $(P+P)/2$ ; AF filter 30 Hz to 20 kHz, measurement in accordance with CCIR 468-2  
 DIN 45405; test circuit 1 a.

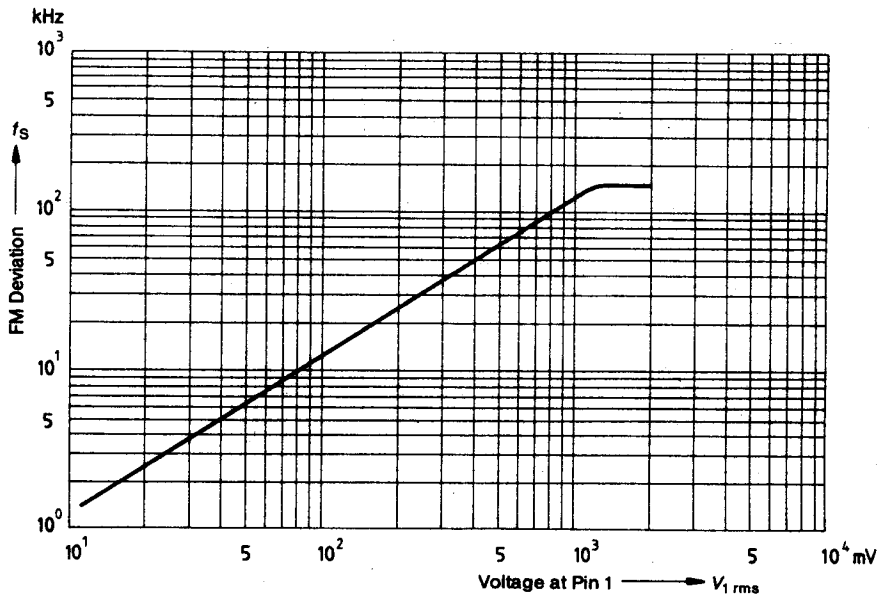
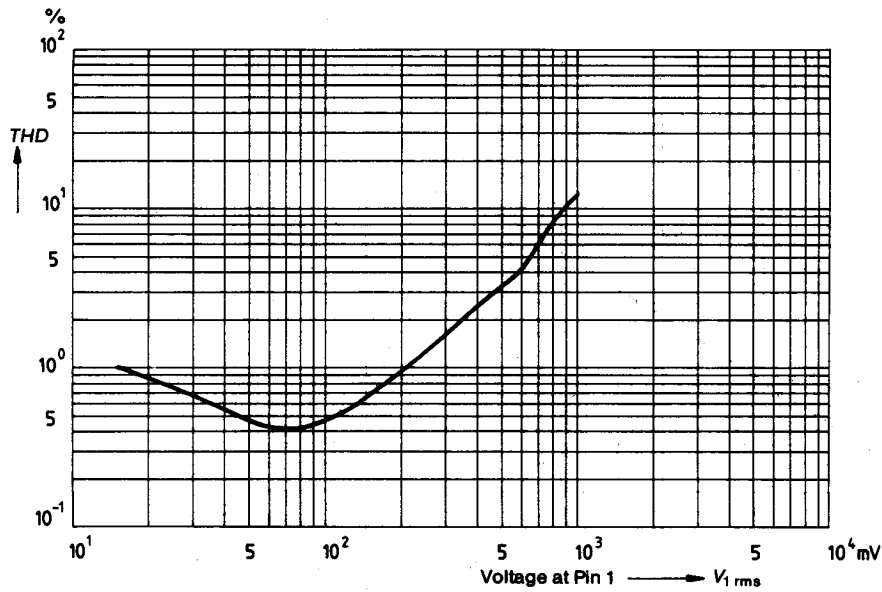

Figure 18

**Measurement of the sound oscillator FM deviation without preemphasis and deemphasis;**  
 $f_{AF} = 1$  kHz; modulation deviation, sensitivity  $(\Delta f_{AF})/(\Delta V_{AF}) = 0.38$  kHz/mV;  $V_{AF} = \text{var}$ ;  
 detector  $(P+P)/2$ ; AF filter 30 Hz to 20 kHz, measurement in accordance with CCIR 468-2  
 DIN 45405; test circuit 1a



**Figure 18a**

Sound oscillator harmonic distortion without preemphasis and deemphasis;  
AF signal routed in at pin 1; AF amplitude = 150 mV<sub>rms</sub>; AF filter 30 Hz to 20 kHz;  
detector (P+P)/2; measurement in accordance with CCIR 468-2 DIN 45405; test circuit 1a

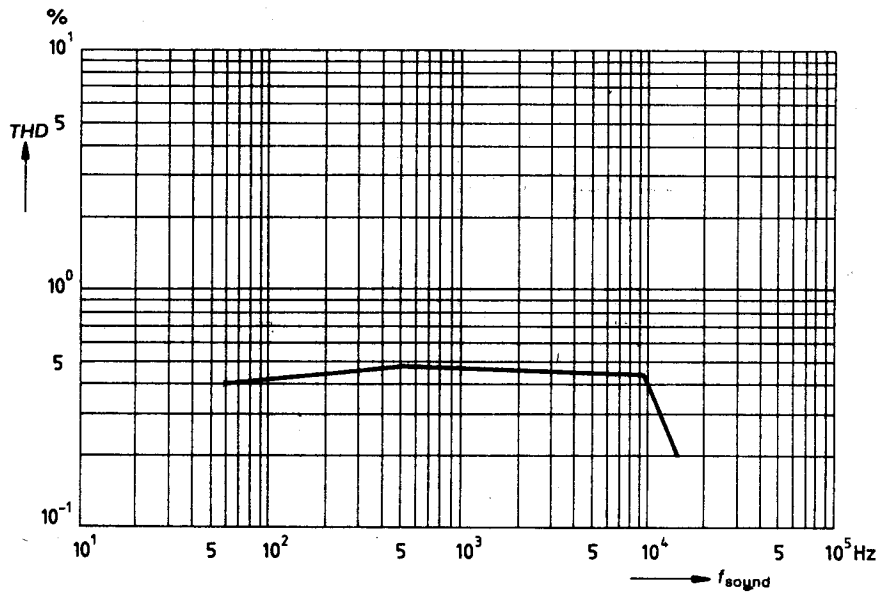
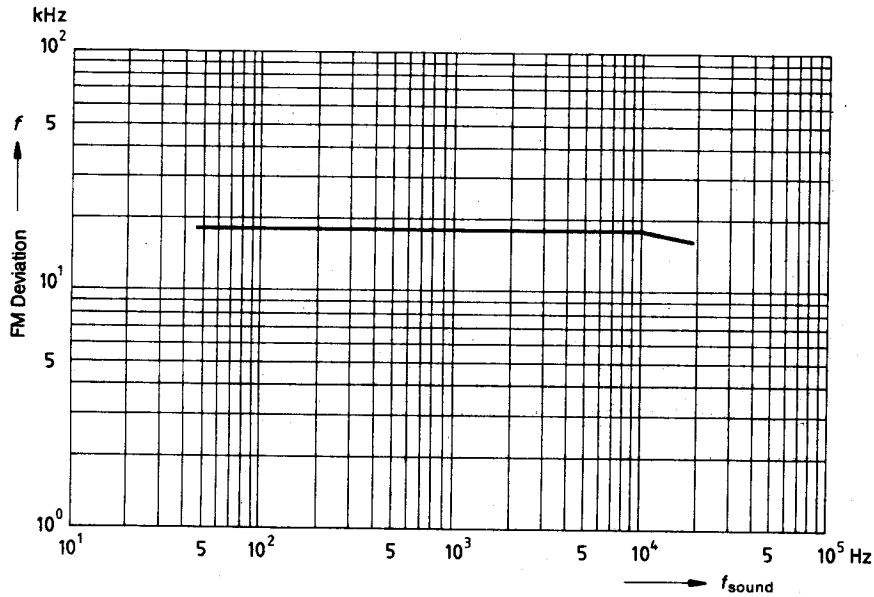

Figure 18 b

**Sound oscillator frequency without preemphasis and deemphasis;**  
AF signal routed in at pin 1; AF amplitude =  $150 \text{ mV}_{\text{rms}}$ ; AF filter 30 Hz to 20 kHz;  
detector  $(P+P)/2$ ; measurement in accordance with CCIR 468-2 DIN 45405; test circuit 1a



**Figure 18c**



**Sound oscillator frequency with pre-/deemphasis;**

AF filter 30 Hz to 20 kHz; measurement in accordance with CCIR 468-2 DIN 45405; test circuit 1;  $V_{AF} = 1 V_{rms}$

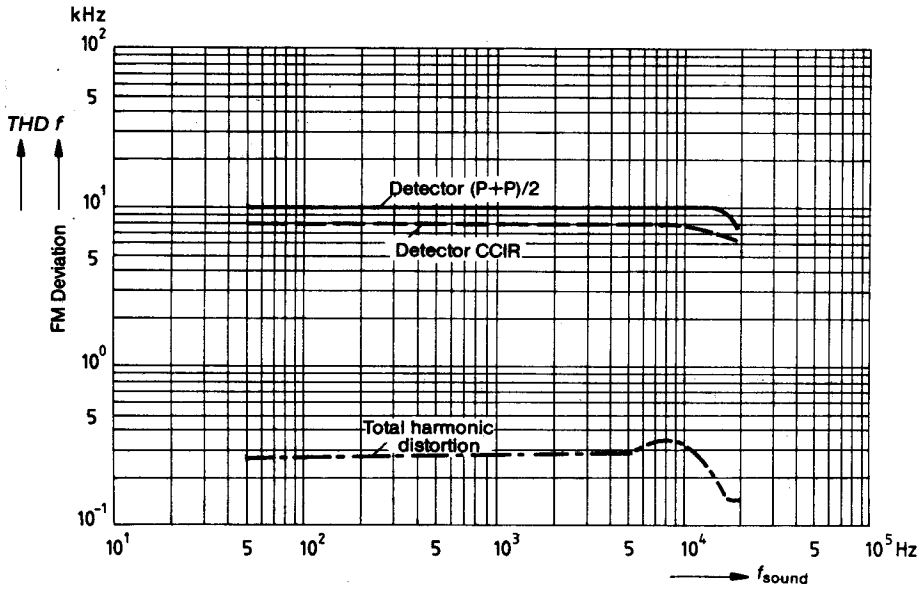

Figure 18 d

**Description of the measurement configuration to measure the video signal control characteristics and the dynamic signal suppression in video frequencies**

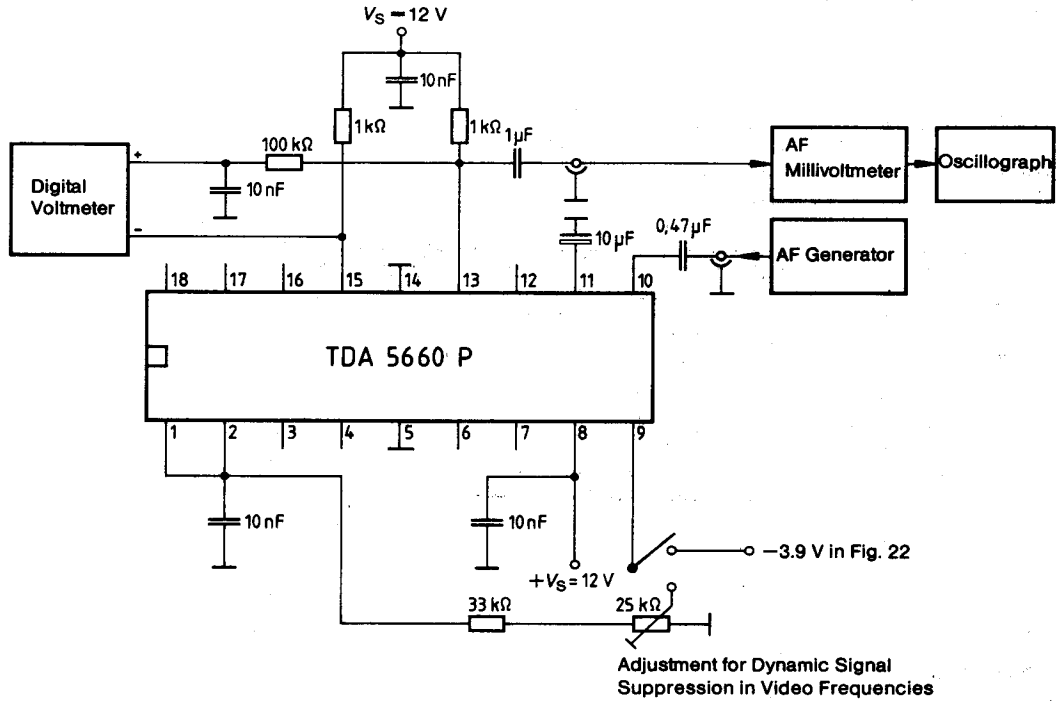
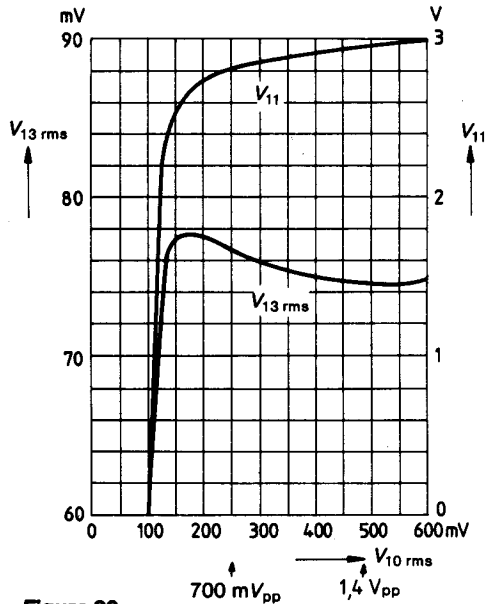

Figure 19

**Characteristic of the video signal control circuit**



- a)  $V_{13\text{ rms}} = f(V_{10\text{ rms}})$ ;  $f_{\text{mod}} = 100\text{ kHz}$
- b)  $V_{11} = f(V_{10\text{ rms}})$ ;  $V_9 = 3.9\text{ V}$

**Figure 20**

**Static and dynamic mixer test with respect to balance characteristics based on a typical component**

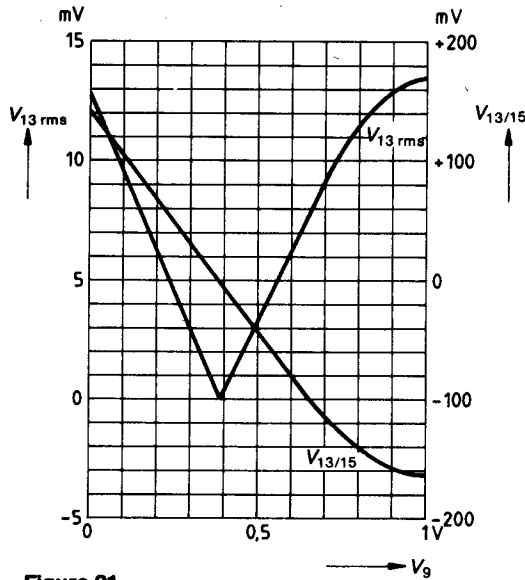

- $V_{13/15} = f(V_9)$
- $V_{13\text{ rms}} = f(V_9)$
- $f = 10\text{ kHz}$

**Figure 21**

7

### Measurement of the static output impedance

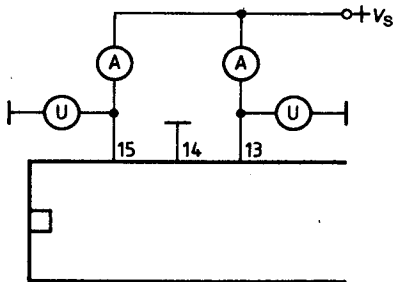

$$Z_{15} = \frac{\Delta V_{15}}{\Delta I_{15}}$$

$$Z_{13} = \frac{\Delta V_{13}}{\Delta I_{13}}$$

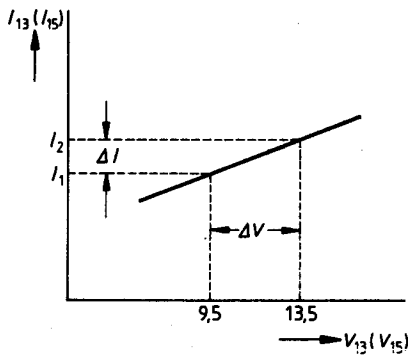
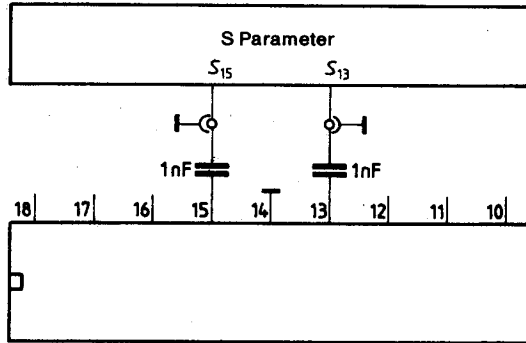

Figure 22

Output circuit S parameter



Typ. output capacity is approx. 1 pF

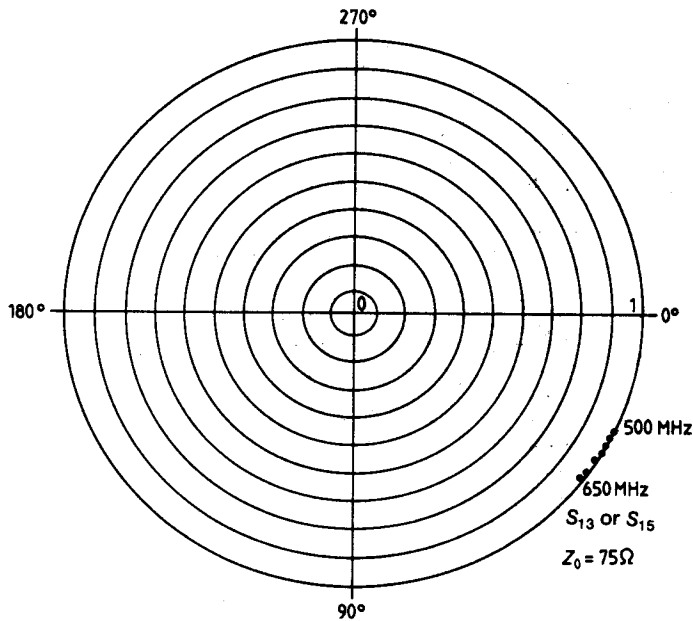

Figure 23

7

Oscillator section S parameter

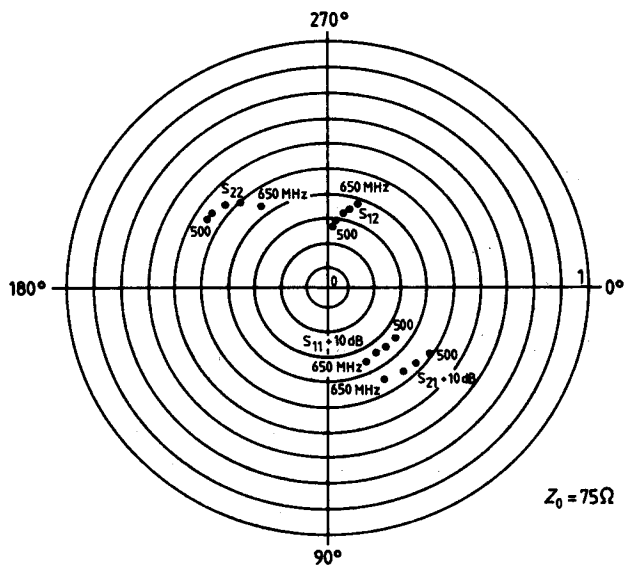
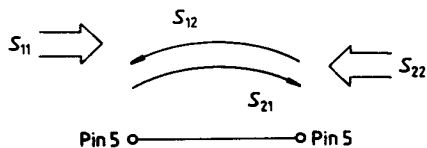
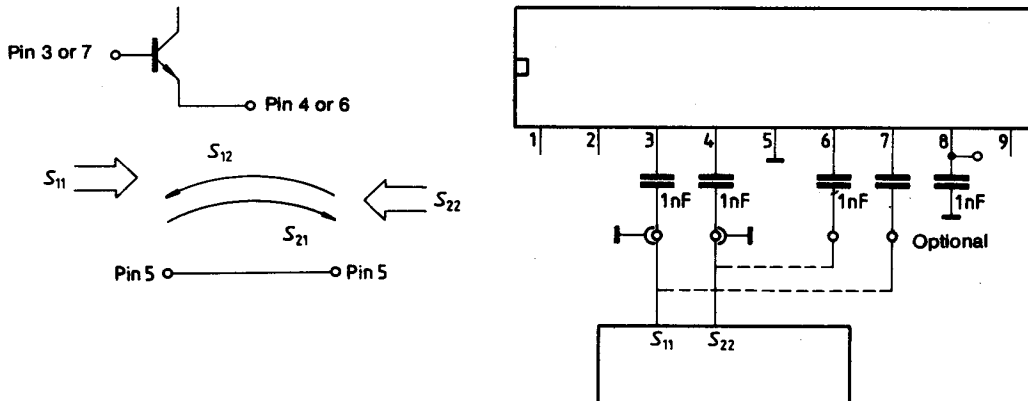
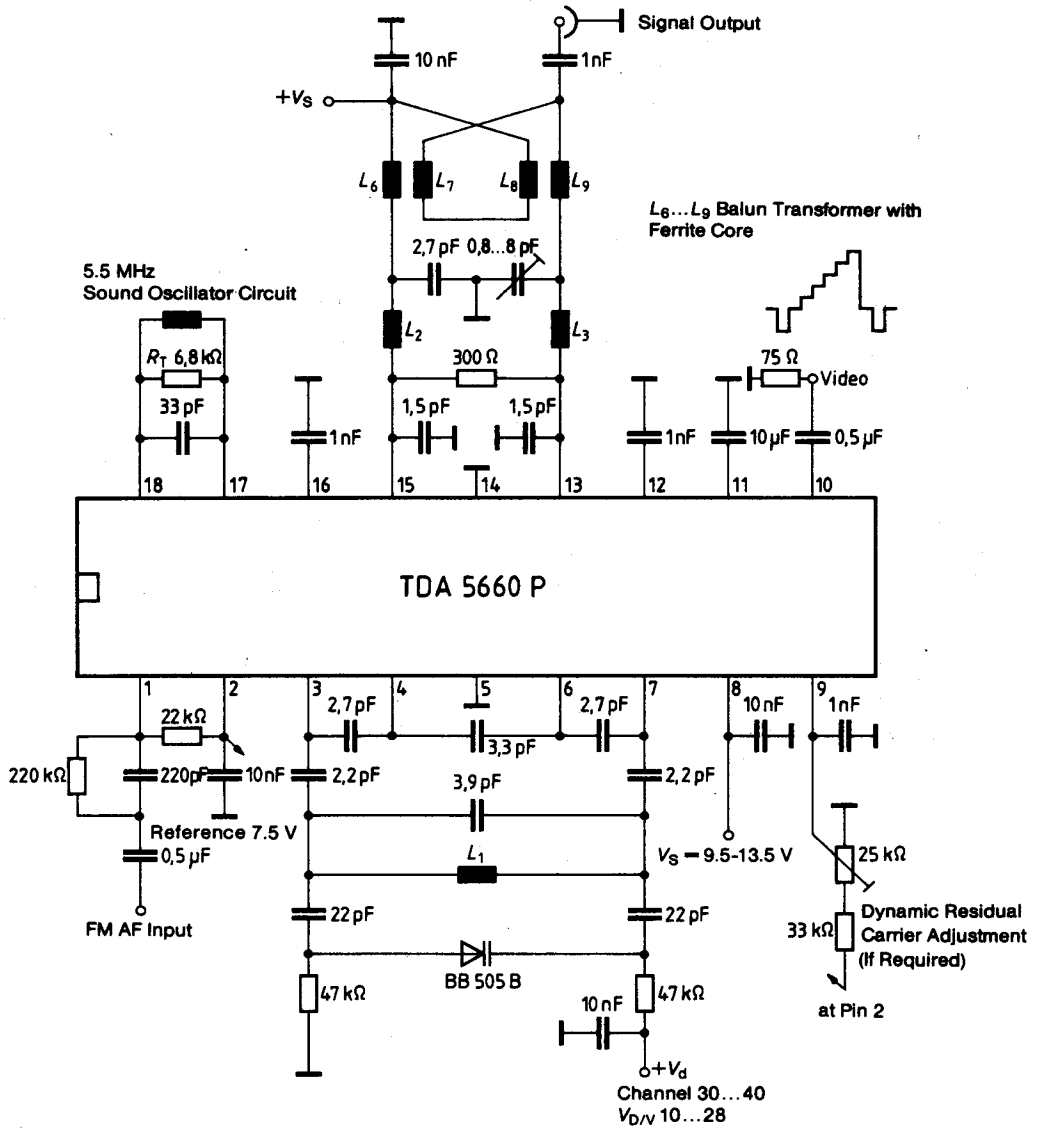

Figure 24

Application circuit 1



7

Application circuit 2

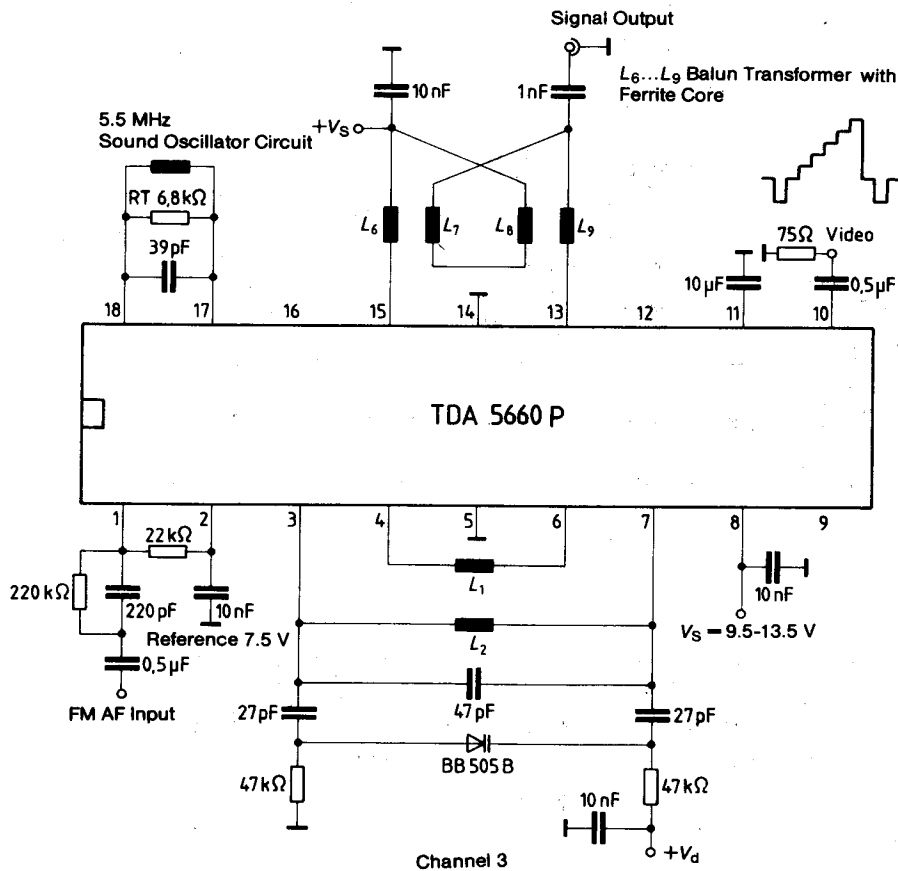



Application circuit 3

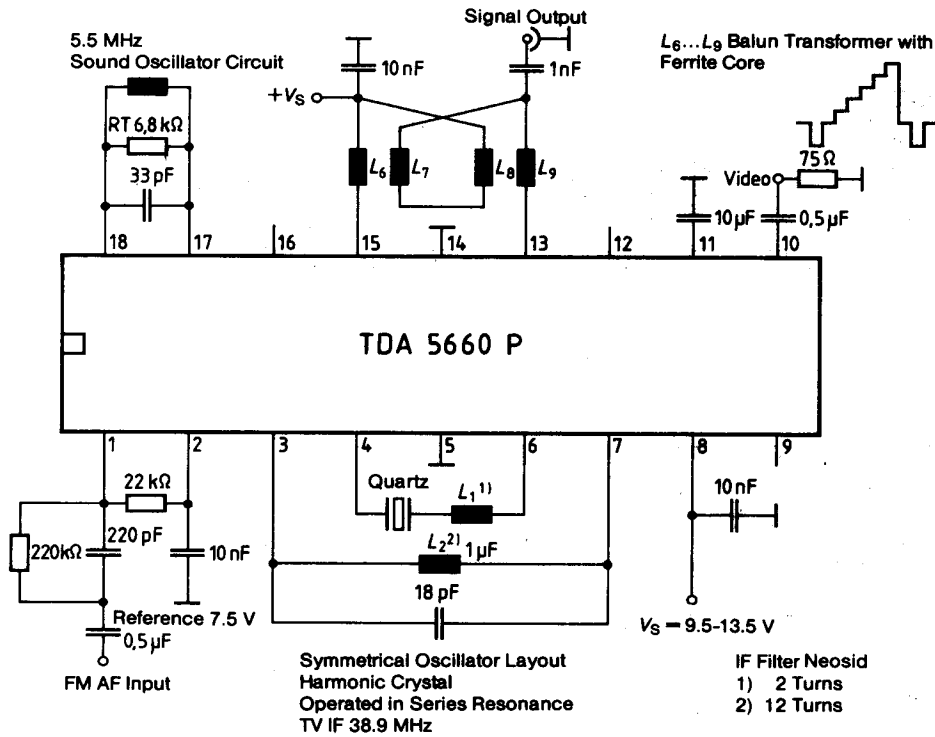

Application circuit 4

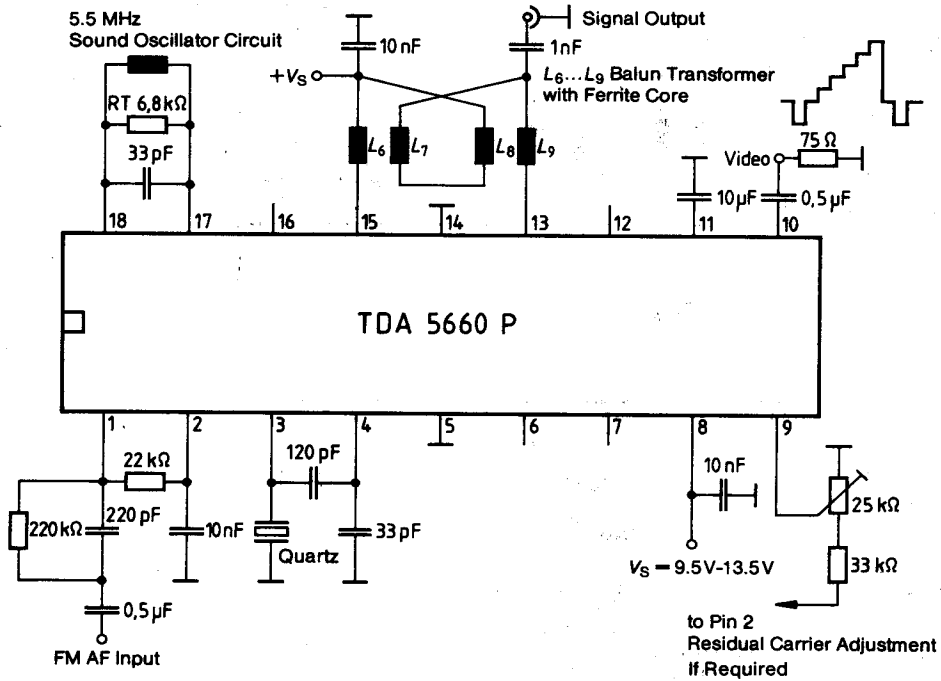

Application circuit 5

