

NPN METAL CAN - LOW NOISE LEVEL AMPLIFIER (Cont'd.)

TYPE NO.	V _{CB}	V _{CE}	V _{EB}	h _{FE} at I _C		V _{CE}	V _{CE(s)} at I _C		f _T	C _{ob}	NF	t _{off}	I _{CBO} at V _{CB}		CASE	
	V	V	V	min	max	V	V	mA	MHz	pF	dB	nS	μA	V		
2N3117	60	60	6	250	500	.01	5	0.35	1.0	60	8	1	—	.01	45	TO-18
2N4383	40	30	5	100	500	.01	5	0.2	10	—	8	2.0	—	.01	—	TO-5
2N4384	40	30	5	100	500	.01	5	0.2	10	—	8	2.0	—	.01	—	TO-18
2N4385	40	30	5	40	500	.01	5	0.2	10	—	8	3.0	—	.01	—	TO-5
2N4386	40	30	5	40	500	.01	5	0.2	10	—	8	3.0	—	.01	—	TO-18

NPN METAL CAN RF/IF OSCILLATOR

TYPE NO.	V _{CB}	V _{CE}	V _{EB}	h _{FE} at I _C		V _{CE}	V _{CE(s)} at I _B I _C			f _T	C _{ob}	I _{CBO} at V _{CB}		CASE	
	V	V	V	min	max	V	V	mA	mA	MHz	pF	μA	V		
2N915	70	50	5	50	200	10	10	—	—	—	250	3.5	—	—	TO-18
2N916	45	45	5	50	200	10	10	—	—	—	300	6	—	—	TO-18
2N917	30	15	3	20	—	3.0	1.0	0.5	0.3	3.0	500	1.7	1.0	15	TO-72
2N917A	30	15	3	20	200	3	10	—	—	—	600	1.7	—	—	TO-72
2N918	30	15	3	20	—	3.0	1.0	0.4	1.0	10	600	1.7	.01	15	TO-72
2N957	40	20	5	45	—	10	10	—	—	—	200	6.0	—	—	TO-18
2N2708	35	20	3	30	200	2	10	—	—	—	700	1.0	—	—	TO-72
2N2865	25	13	3	20	200	4	10	—	—	—	600	2.5	—	—	TO-72
2N4134	30	30	3	25	200	4.0	10	3.0	1	10	350	45	.05	10	TO-72
2N4135	30	30	3	25	200	4	10	3.0	1	10	425	45	.05	10	TO-72

PNP METAL CAN - SWITCHING AND GENERAL PURPOSE

TYPE NO.	V _{CB}	V _{CE}	V _{EB}	h _{FE} at I _C		V _{CE}	V _{CE(s)} at I _B I _C			f _T	C _{ob}	I _{CBO} at V _{CB}		CASE	
	V	V	V	min	max	V	V	mA	mA	MHz	pF	μA	V		
2N721	50	35	5	20	45	150	10	1.5	15	150	50	45	1	30	TO-18
2N722	50	35	5	30	90	150	10	1.5	15	150	60	45	1	30	TO-18
2N722A	50	35	5	30	90	150	10	1.5	15	150	60	45	0.1	30	TO-18
2N726	25	20	5	15	45	10	1	0.6	1	10	140	5	1	25	TO-18
2N727	25	20	5	30	120	10	1	0.6	1	10	140	5	1	25	TO-18
2N858	40	40	25	15	75	1.0	6	0.15	0.5	5	—	9	0.1	10	TO-18
2N859	40	40	25	30	120	1.0	6	0.15	0.5	5	—	9	0.1	10	TO-18
2N860	25	25	20	15	45	1.0	6	0.15	0.8	5	—	9	0.1	10	TO-18
2N861	25	25	20	30	100	1.0	6	0.15	0.5	5	—	9	0.1	10	TO-18
2N862	15	15	30	20	60	1.0	6	0.15	0.8	5	—	9	0.1	10	TO-18
2N863	15	15	10	40	120	1.0	6	0.15	0.5	5	—	9	0.1	10	TO-18
2N864	6	6	6	25	125	1.0	6	0.10	0.5	5	—	9	0.1	10	TO-18
2N865	10	6	6	100	350	1.0	6	0.10	0.5	5	—	9	0.1	10	TO-18
2N869	25	18	5	20	60	10	5	1	1	10	160	9	.01	25	TO-18
2N869A	25	18	5	40	120	10	5	.15	1	10	400	6	.01	15	TO-18
2N978	30	20	5	15	60	150	10	1.5	15	150	40	45	5.0	10	TO-18
2N1084	60	50	5	15	60	1500	10	1.5	50	500	25	—	1	30	TO-5
2N1118	25	25	10	15	—	1.0	6	—	—	—	—	12	1.0	25	TO-5
2N1118A	25	25	10	15	35	1.0	6	—	—	—	—	12	1.0	25	TO-5
2N1119	10	10	10	15	—	15	0.5	0.15	0.8	5	—	12	0.1	10	TO-5
2N1131	50	35	5	20	45	150	10	1.5	15	150	90	45	1	30	TO-5
2N1131A	60	40	5	20	45	150	10	1.5	15	150	90	45	0.5	45	TO-5
2N1132	50	35	5	30	90	150	10	1.5	15	150	90	45	1	30	TO-5
2N1132A	60	40	5	30	90	150	10	1.5	15	150	90	45	0.5	45	TO-5
2N1132B	70	50	6	30	75	150	10	1.5	15	150	90	30	0.010	50	TO-5
2N1254	30	30	5	25	50	10	1	0.3	2	10	—	10	0.2	—	TO-5
2N1255	30	30	5	40	80	10	1	0.3	2	10	—	10	0.2	—	TO-5
2N1256	40	40	5	25	50	10	1	0.3	2	10	—	10	0.2	—	TO-5
2N1257	40	40	5	40	80	10	1	0.3	2	10	—	10	0.2	—	TO-5
2N1258	30	30	5	75	150	10	1	0.6	2	10	—	10	0.2	—	TO-5
2N1259	30	50	5	25	100	10	1	0.3	2	10	—	10	0.2	—	TO-5
2N1991	30	20	5	15	60	150	10	1.5	15	150	40	45	5.0	10	TO-18
2N2175	6	6	6	30	—	.02	1.5	—	—	—	3	—	1.0	—	TO-5
2N2176	6	6	6	30	—	.02	1.5	—	—	—	8	—	1.0	—	TO-18
2N2177	6	6	6	35	—	.05	4.5	—	—	—	8	—	.005	—	TO-5
2N2178	6	6	6	35	—	.05	4.5	—	—	—	8	—	.005	—	TO-18
2N2303	40	35	5	75	200	150	10	1.5	15	150	60	45	—	—	TO-5
2N2377	25	25	10	15	120	1.0	6	—	—	—	—	12	1.0	25	TO-18
2N2378	10	10	10	15	—	5	0.5	0.15	0.8	5	—	12	0.1	10	TO-18
2N2605	60	45	6	100	300	.01	5	0.5	0.5	10	30	6	.01	45	TO-46

CASE OUTLINE DRAWINGS

D

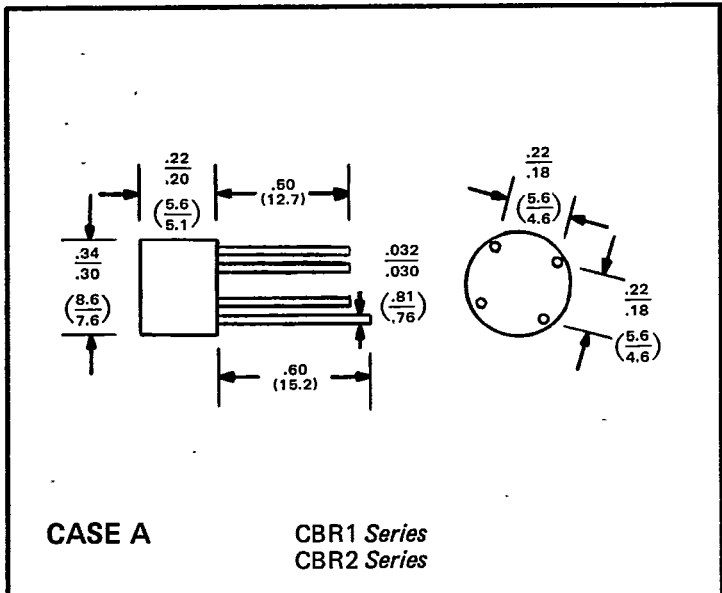

CASE A

CBR1 Series
CBR2 Series

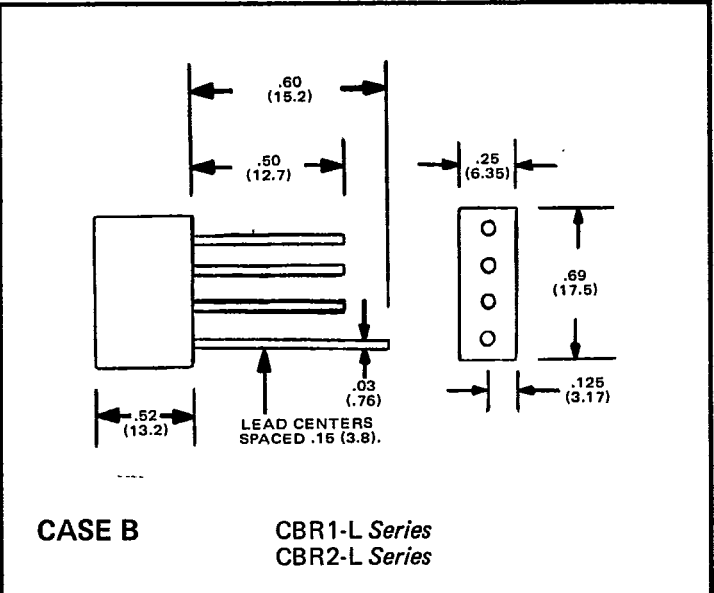

CASE B

CBR1-L Series
CBR2-L Series

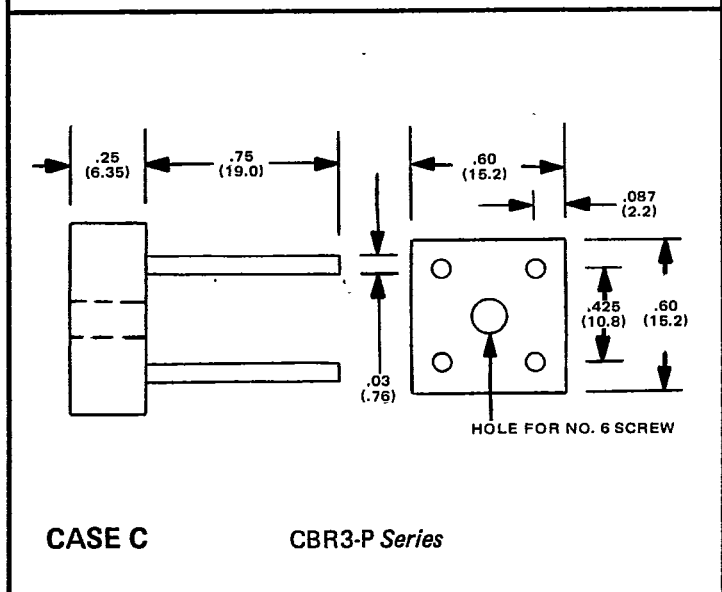

CASE C

CBR3-P Series

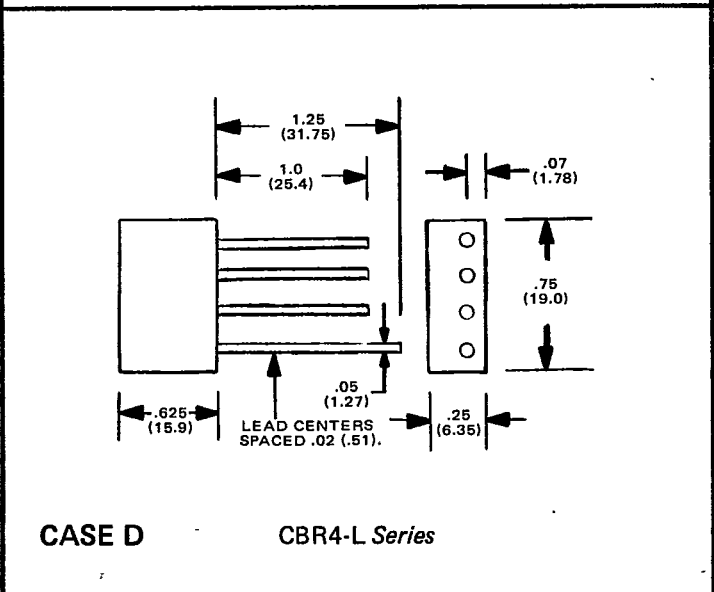

CASE D

CBR4-L Series

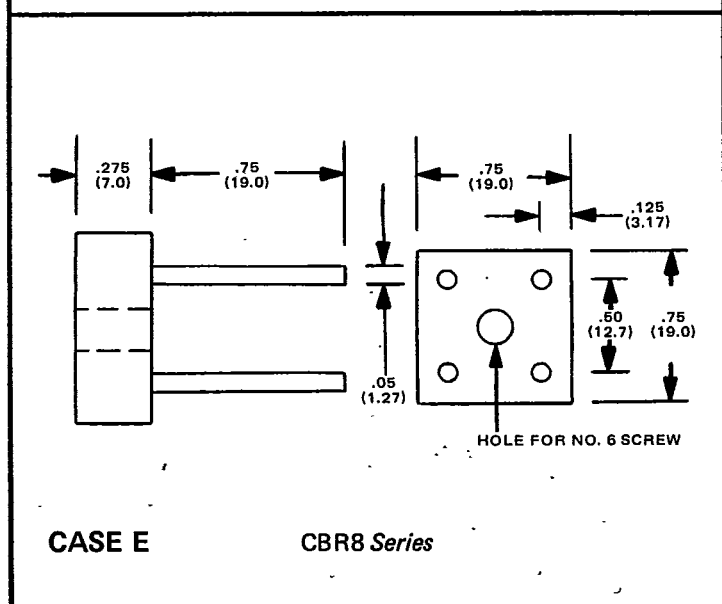

CASE E

CBR8 Series

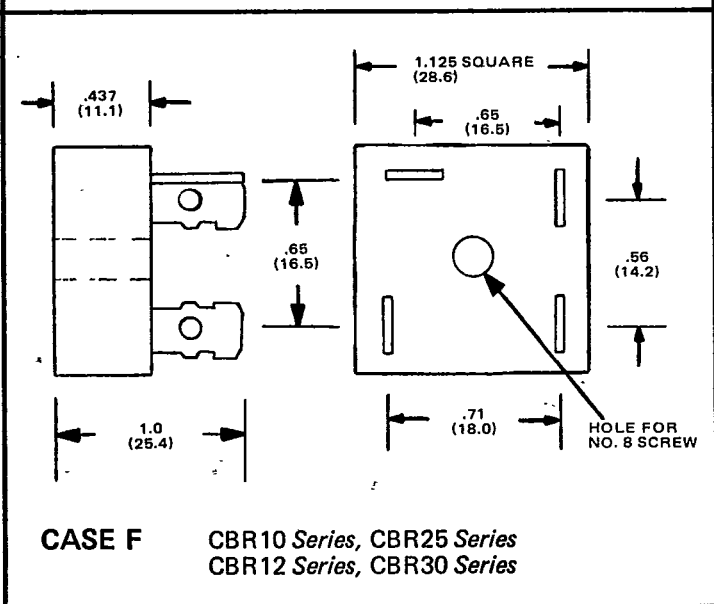

CASE F

CBR10 Series, CBR25 Series
CBR12 Series, CBR30 Series

All Dimensions in Inches (Millimeters)

Drawings Not To Scale

f

MECHANICAL OUTLINE DRAWINGS

TO-5

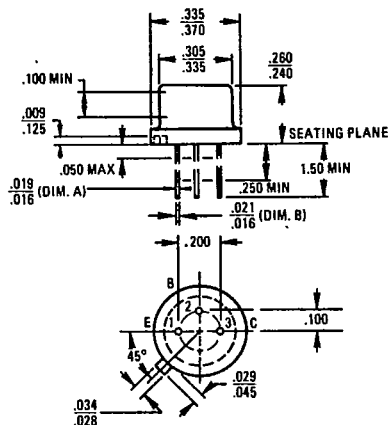

TO-18

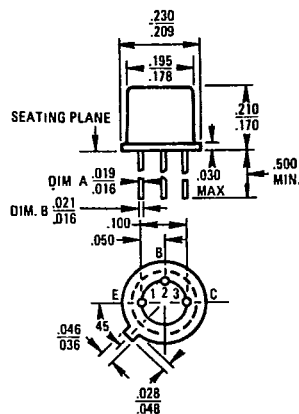

TO-39

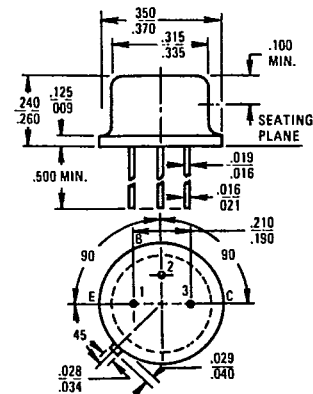

TO-46

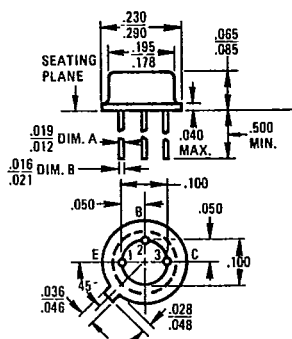

TO-72

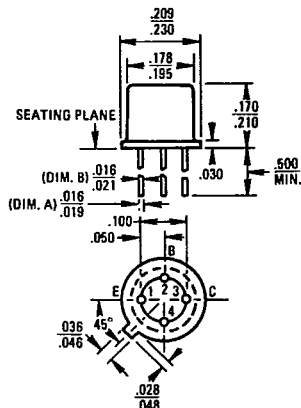

TO-92

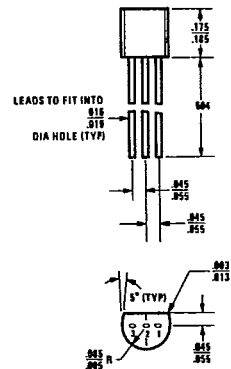

TO-98

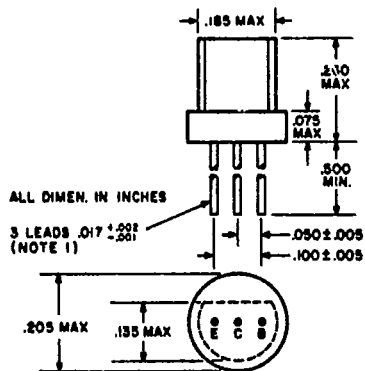

TO-105

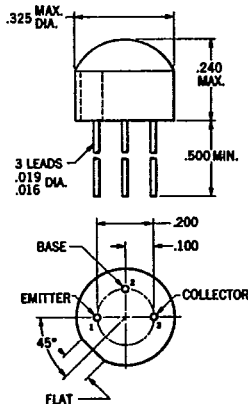

TO-106

