

# HAMAMATSU

## PHOTOMULTIPLIER TUBE R9220

High QE Multialkali Photocathode  
New Electro-Optical Design  
28 mm (1-1/8 Inch) Diameter, 9-stage, Side-on Type

### FEATURES

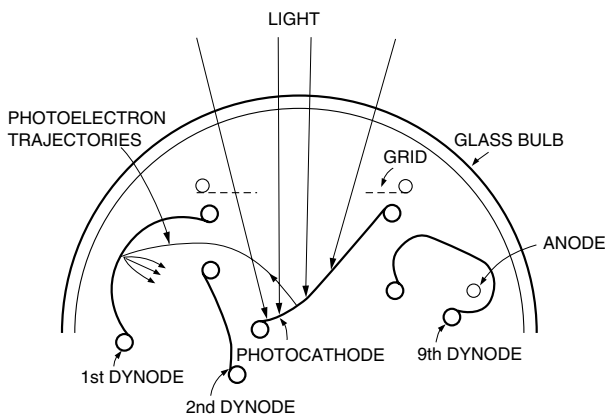
- High Cathode Sensitivity
  - Luminous ..... 450  $\mu\text{A}/\text{lm}$  (Typ.)
  - Radiant at 450 nm (peak) ..... 85 mA/W (Typ.)
  - Quantum Efficiency at 260 nm (peak) .... 26.3 % (Typ.)
- High Anode Sensitivity at 1000 V
  - Luminous ..... 4500 A/lm (Typ.)
  - Radiant at 450 nm (peak) .....  $8.5 \times 10^5$  A/W (Typ.)
- Wide Spectral response ..... 185 nm to 900 nm
- High Signal to Noise Ratio
- Newly Designed Electro Optical Structure

### APPLICATIONS

- Biomedical Fluorescence Detection
- Laser Scanning Detection
- Spectroscopy
- Semiconductor Inspection
- Environmental Monitoring

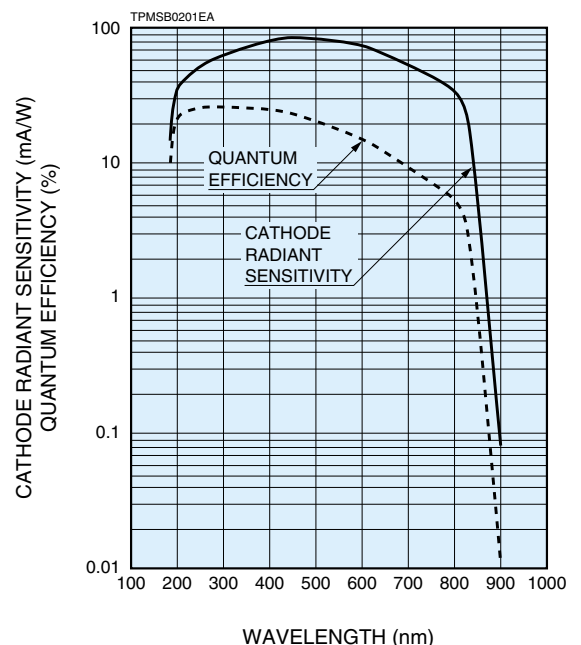


Figure 1: Electro optical Structure



TPMSC0024EB

Figure 2: Typical Spectral Response



# PHOTOMULTIPLIER TUBE R9220

## SPECIFICATIONS

### GENERAL

Parameter		Description/Value	Unit
Spectral Response		185 to 900	nm
Wavelength of Maximum Response		450	nm
Photocathode	Material	Multialkali	—
	Minimum Effective Area	8 × 24	mm
Window Material		UV glass	—
Dynode	Structure	Circular-cage	—
	Number of Stages	9	—
Direct Interelectrode Capacitances	Anode to Last Dynode	4	pF
	Anode to All Other Electrodes	6	pF
Base		11-pin base JEDEC No. B11-88	—
Weight		Approx. 45	g
Operating Ambient Temperature		-30 to +50	°C
Storage Temperature		-30 to +50	°C
Suitable Socket		E678-11A (Sold Separately)	—
Suitable Socket Assembly		E717-63 (Sold Separately)	—

### MAXIMUM RATINGS (Absolute Maximum Values)

Parameter		Value	Unit
Supply Voltage	Between Anode and Cathode	1250	V
	Between Anode and Last Dynode	250	V
Average Anode Current <sup>A</sup>		0.1	mA

### CHARACTERISTICS (at 25 °C)

Parameter		Min.	Typ.	Max.	Unit	
Cathode Sensitivity	Quantum Efficiency	at 260 nm	—	26.3	%	
		at 450 nm	—	23.4	%	
		at 633 nm	—	13.3	%	
	Luminous <sup>B</sup>	375	450	—	μA/lm	
	Radiant	at 450 nm	—	85	—	mA/W
		at 633 nm	—	68	—	mA/W
Red/White Ratio <sup>C</sup>		—	0.4	—	—	
Blue Sensitivity Index <sup>D</sup>		—	12.5	—	—	
Anode Sensitivity	Luminous <sup>E</sup>	1000	4500	—	A/lm	
	Radiant at 450 nm (peak)	—	$8.5 \times 10^5$	—	A/W	
Gain <sup>E</sup>		—	$1.0 \times 10^7$	—	—	
Anode Dark Current <sup>F</sup> (After 30 min Storage in Darkness)		—	10	50	nA	
Time Response	Anode Pulse Rise Time <sup>G</sup>	—	2.2	—	ns	
	Electron Transit Time <sup>H</sup>	—	22	—	ns	
	Transit Time Spread (TTS) <sup>I</sup>	—	1.2	—	ns	
Anode Current Stability <sup>J</sup>	Light Hysteresis	—	0.1	—	%	
	Voltage Hysteresis	—	1.0	—	%	

### NOTES

- A: Averaged over any interval of 30 seconds maximum.  
 B: The light source is a tungsten filament lamp operated at a distribution temperature of 2856K. Supply voltage is 100 volts between the cathode and all other electrodes connected together as anode.  
 C: Red/White ratio is the quotient of the cathode current measured using a red filter (Toshiba R-68) interposed between the light source and the tube by the cathode current measured with the filter removed under the same conditions as Note B.  
 D: The value is cathode output current when a blue filter (Corning CS 5-58 polished to 1/2 stock thickness) is interposed between the light source and the tube under the same condition as Note B.  
 E: Measured with the same light source as Note B and with the voltage distribution ratio shown in Table 1 below.

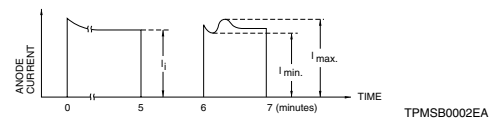
Table 1: Voltage Distribution Ratio

Electrodes	K	Dy1	Dy2	Dy3	Dy4	Dy5	Dy6	Dy7	Dy8	Dy9	P
Ratio	1	1	1	1	1	1	1	1	1	1	1

Supply Voltage: 1000 V, K: Cathode, Dy: Dynode, P: Anode

- F: Measured with the same supply voltage and voltage distribution ratio as Note E after removal of light.  
 G: The rise time is the time for the output pulse to rise from 10 % to 90 % of the peak amplitude when the entire photocathode is illuminated by a delta function light pulse.  
 H: The electron transit time is the interval between the arrival of delta function light pulse at the entrance window of the tube and the time when the anode output reaches the peak amplitude. In measurement, the whole photocathode is illuminated.  
 I: Also called transit time jitter. This is the fluctuation in electron transit time between individual pulses in the single photoelectron mode, and may be defined as the FWHM of the frequency distribution of electron transit times.  
 J: Hysteresis is temporary instability in anode current after light and voltage are applied.

$$\text{Hysteresis} = \frac{I_{\text{max.}} - I_{\text{min.}}}{I_i} \times 100(\%)$$



#### (1) Light Hysteresis

The tube is operated at 750 volts with an anode current of 1 microampere for 5 minutes. The light is then removed from the tube for a minute. The tube is then re-illuminated by the previous light level for a minute to measure the variation.

#### (2) Voltage Hysteresis

The tube is operated at 300 volts with an anode current of 0.1 micro-ampere for 5 minutes. The light is then removed from the tube and the supply voltage is quickly increased to 800 volts. After a minute, the supply voltage is then reduced to the previous value and the tube is re-illuminated for a minute to measure the variation.

Figure 3: Typical Temperature Characteristics of Dark Current (at 1000 V, after 30 minute storage in darkness)

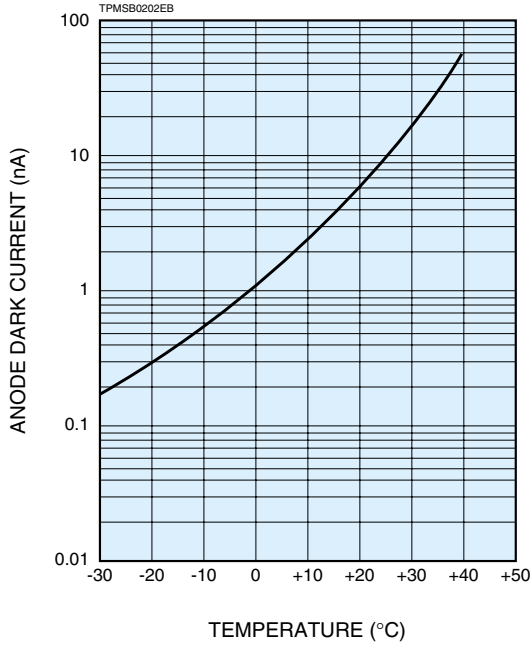


Figure 4: Anode Luminous Sensitivity and Gain Characteristics

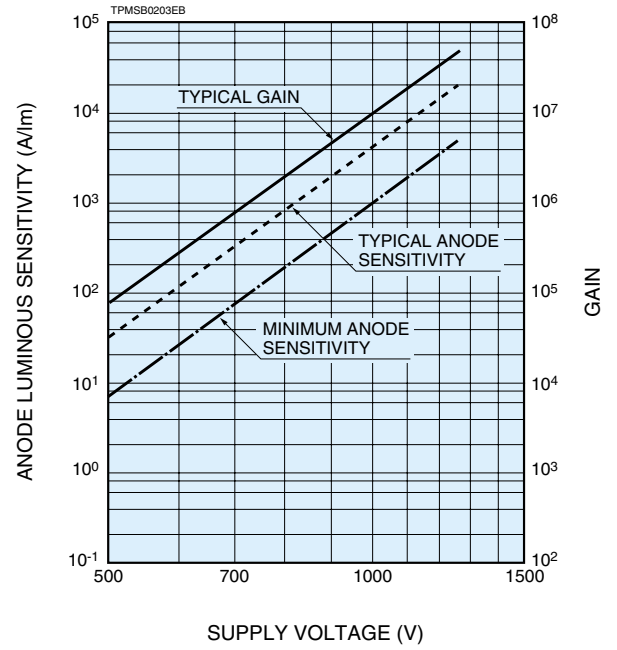


Figure 5: Typical Time Response

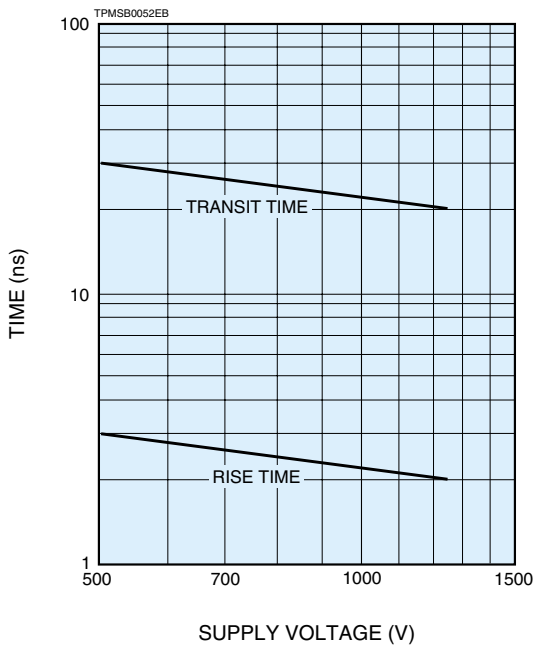
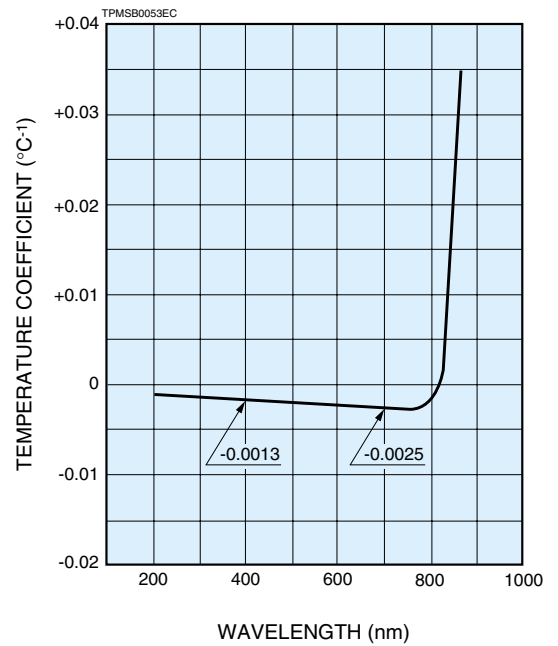


Figure 6: Typical Temperature Coefficient of Anode Sensitivity



# PHOTOMULTIPLIER TUBE R9220

Figure 7: Dimensional Outline and Basing Diagram (Unit: mm)

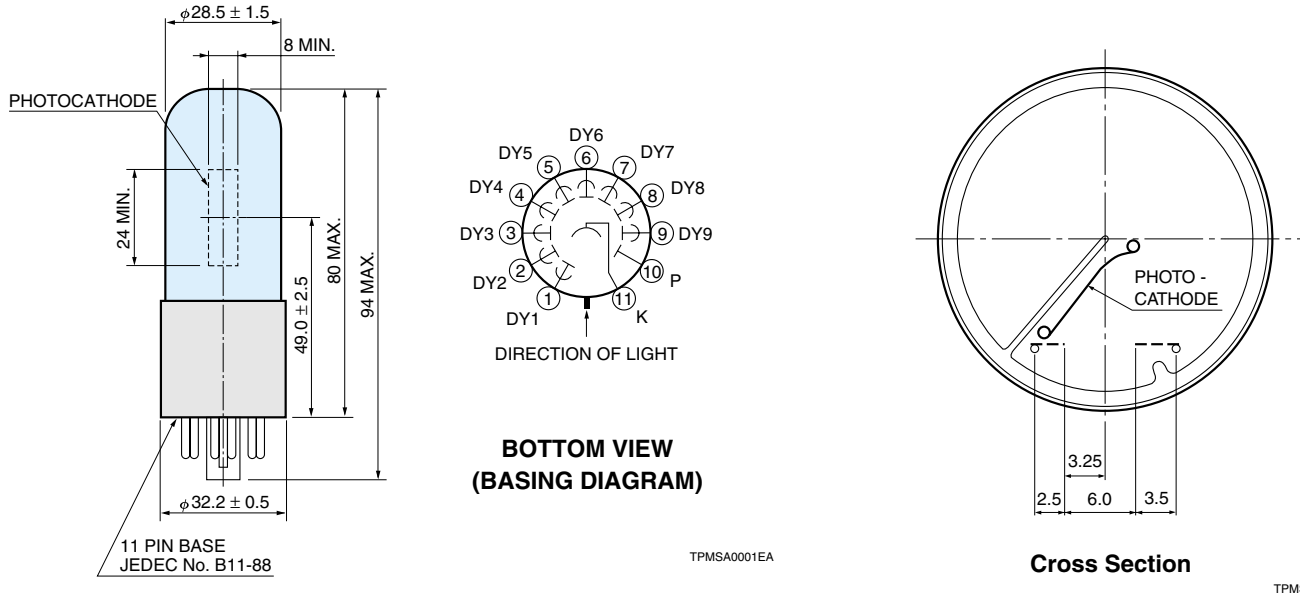


Figure 8: Socket (Unit: mm) Sold Separately

E678-11A

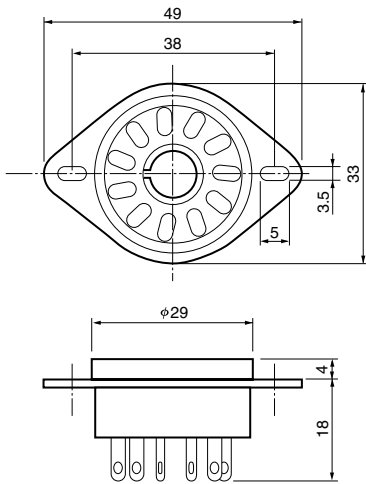
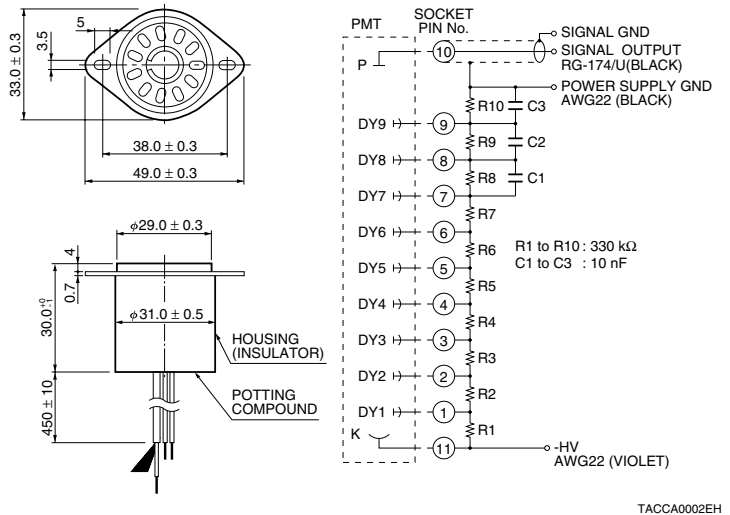


Figure 9: D-Type Socket Assembly (Unit: mm) Sold Separately

E717-63



\* Hamamatsu also provides C4900 series compact high voltage power supplies and C6270 series DP type socket assemblies which incorporate a DC to DC converter type high voltage power supply.

**Warning—Personal Safety Hazards**

Electrical Shock—Operating voltages applied to this device present a shock hazard.

\* PATENT PENDING: JAPAN 4, USA 4, EUROPE 4

# HAMAMATSU

WEB SITE [www.hamamatsu.com](http://www.hamamatsu.com)

HAMAMATSU PHOTONICS K.K., Electron Tube Division

314-5, Shimokanzo, Iwata City, Shizuoka Pref., 438-0193, Japan, Telephone: (81)539/62-5248, Fax: (81)539/62-2205

U.S.A.: Hamamatsu Corporation: 360 Foothill Road, P. O. Box 6910, Bridgewater, N.J. 08807-0910, U.S.A., Telephone: (1)908-231-0960, Fax: (1)908-231-1218 E-mail: [usa@hamamatsu.com](mailto:usa@hamamatsu.com)

Germany: Hamamatsu Photonics Deutschland GmbH: Arzbergerstr. 10, D-82211 Herrsching am Ammersee, Germany, Telephone: (49)8152-375-0, Fax: (49)8152-2658 E-mail: [info@hamamatsu.de](mailto:info@hamamatsu.de)

France: Hamamatsu Photonics France S.A.R.L.: 19, Rue du Saule Trapu, Parc du Moulin de Massy, 91882 Massy Cedex, France, Telephone: (33)1 69 53 71 00, Fax: (33)1 69 53 71 10 E-mail: [infos@hamamatsu.fr](mailto:infos@hamamatsu.fr)

United Kingdom: Hamamatsu Photonics UK Limited: 2 Howard Court, 10 Tewin Road Welwyn Garden City Hertfordshire AL7 1BW, United Kingdom, Telephone: 44-(0)1707-294888, Fax: 44-(0)1707-325777 E-mail: [info@hamamatsu.co.uk](mailto:info@hamamatsu.co.uk)

North Europe: Hamamatsu Photonics Norden AB: Smidesvägen 12, SE-171-41 SOLNA, Sweden, Telephone: (46)8-509-031-00, Fax: (46)8-509-031-01 E-mail: [info@hamamatsu.se](mailto:info@hamamatsu.se)

Italy: Hamamatsu Photonics Italia: S.R.L.: Strada della Moia, 1/E, 20020 Arese, (Milano), Italy, Telephone: (39)02-935 81 733, Fax: (39)02-935 81 741 E-mail: [info@hamamatsu.it](mailto:info@hamamatsu.it)

TPMS1071E02  
JUL. 2006 IP