

### HS-169 Single Frequency Oscillator 53.125MHz

#### Description

The **HS-169** crystal oscillator is designed to support the Tachyon™ clocking requirements at 53.125MHz.

#### Features

- Meets HP TACHYON™ Clock Generator
- Will withstand vapor phase temperatures of 253°C for 4 minutes maximum
- Space-saving alternative to discrete component oscillators
- High shock resistance, to 3000g
- All metal, resistance weld, hermetically sealed package
- Low Jitter
- High Q Crystal actively tuned oscillator circuit
- Power supply decoupling internal
- No internal PLL avoids cascading PLL problems
- Gold plated leads - Solder dipped leads available upon request
- Low power consumption
- RoHS Compliant, Lead Free Construction (unless solder dipped leads are supplied)

#### Electrical Connection

Pin	Connection
1	N.C.
7	Grd & Case
8	Output
14	V <sub>CC</sub>

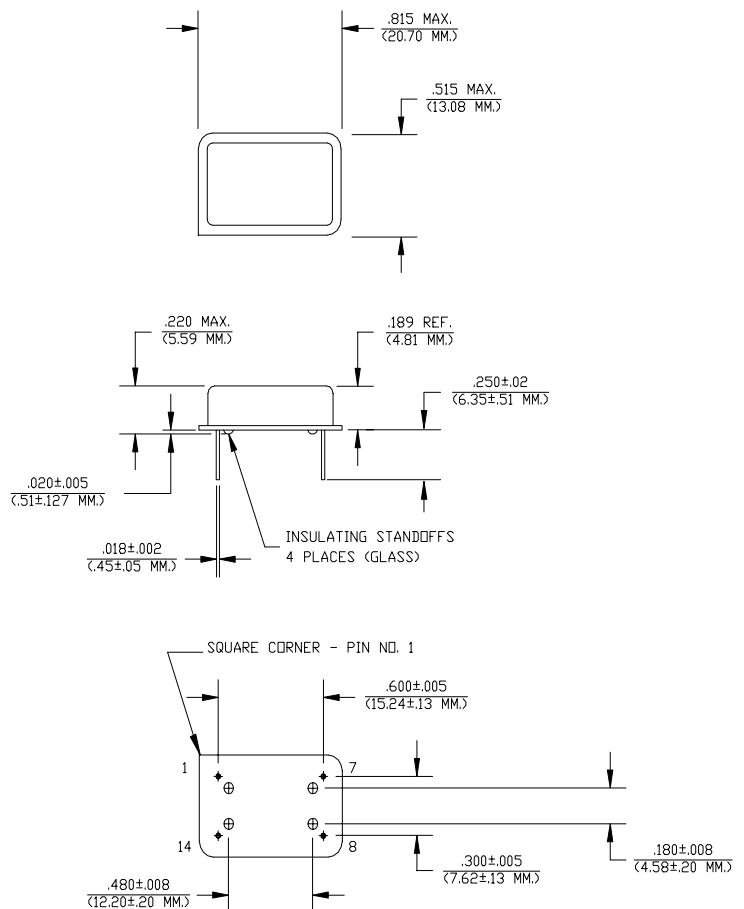

## HS-169 Continued Single Frequency Oscillator 53.125MHz

Rev. G

### Operating Conditions and Output Characteristics

#### Electrical Characteristics

Parameter	Symbol	Conditions	Min	Typical	Max
Duty Cycle	----	@ $V_{CC}/2$	45/55%	----	55/45%
Logic 0	$V_{OL}$	@ 16mA	----	0.3V	0.4V
Logic 1	$V_{OH}$	@ 0.4mA	2.4V	4.0V	----
Rise & Fall Time	tr,tf	@ 0.4 to 2.4V	----	----	2.8 ns
Jitter, RMS <sup>(2)</sup>	----	----	----	----	5 psec
Frequency Stability <sup>(1)</sup>	dF/F	Overall conditions including: voltage, calibration, temp., 20 yr aging, shock, vibration	-100ppm	----	+100ppm

#### General Characteristics

Parameter	Symbol	Conditions	Min	Typical	Max
Supply Voltage	$V_{CC}$	----	4.75V	5.0V	5.25V
Supply Current	$I_{CC}$	No Load	0.0 mA	----	60 mA
Output current	$I_O$	----	0.0 mA	----	$\pm 25.0$ mA
Operating temperature	$T_A$	----	0°C	----	70°C
Storage temperature	$T_S$	----	-55°C	----	125°C
Power Dissipation	$P_D$	----	----	----	315 mW
Lead temperature	$T_L$	Soldering, 10 sec.	----	----	300°C
Load	----	----	----	----	10 TTL gate
Start-up Time	$t_s$	----	----	----	3 ms

#### Environmental and Mechanical Characteristics

Mechanical Shock	Per MIL-STD-202, Method 213, Condition E
Thermal Shock	Per MIL-STD-833, Method 1011, Condition A
Vibration	0.060" double amplitude 10 Hz to 55 Hz, 35g's 55Hz to 2000 Hz
Soldering Condition	300°C for 10 seconds
Hermetic Seal	Leak rate less than $1 \times 10^{-8}$ atm.cc/sec of helium

#### Footnotes:

- Standard frequency stability ( $\pm 20, \pm 25, \pm 50$ ppm & others available)
- Jitter performance is frequency dependent. Please contact factory for full characterization. RMS jitter bandwidth of 12kHz to 20MHz.

Creating a Part Number	
<b>HS - X16X - FREQ</b>	
<b>Package Code</b>	<b>Tolerance/Performance</b>
HS Leaded 4 pin (14 pin)	0 $\pm 100$ ppm 0-70°C
SM Leaded 4 pin (14 pin) SMD	1 $\pm 50$ ppm 0-70°C
Gull Wing	7 $\pm 25$ ppm 0-70°C
<b>Input Voltage</b>	9 Customer Specific
Code Specification	A $\pm 20$ ppm 0-70°C
A 3.3V	B $\pm 50$ ppm -40 to +85°C
5V	C $\pm 100$ ppm -40 to +85°C

#### Test Load:

