

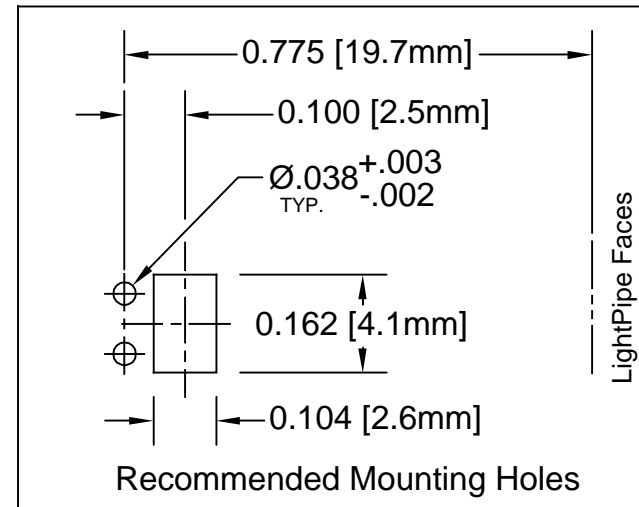

REV.	DESCRIPTION	DATE	APPROVED
A	Engineering Update w/o Changes	03/09/04	M. C.
B	TYPO Correction, Dim. 0.775" was 0.740".	05/11/05	M. C.
C	Updated Material Code.	02/12/07	M. C.

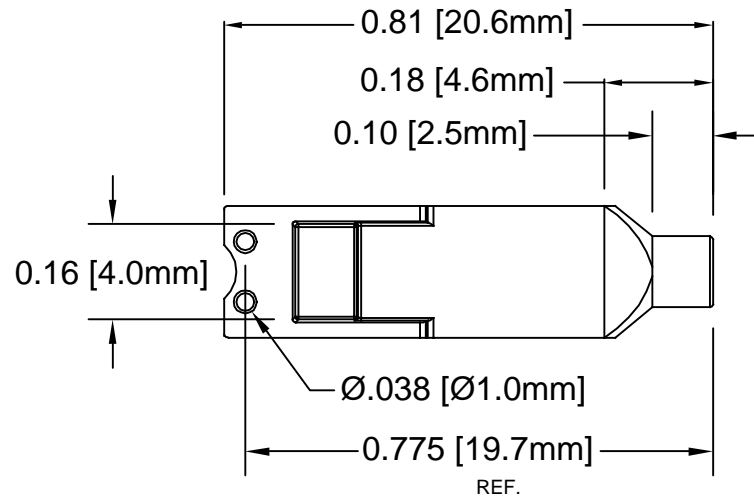
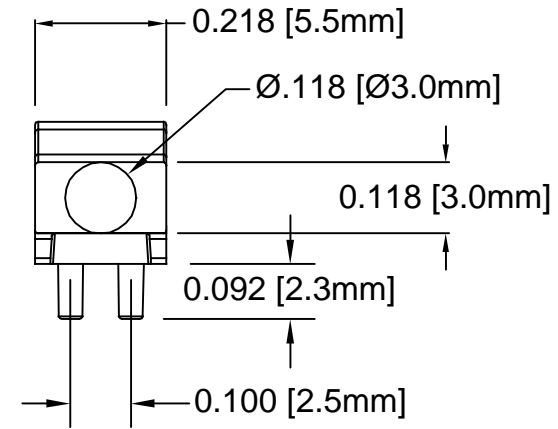
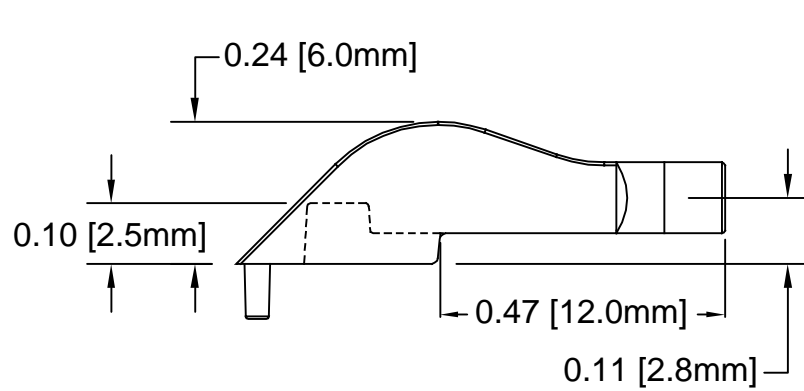

2. MATERIAL: POLYCARBONATE, 94V-0, CLEAR. BIVAR MATERIAL CODE 47-CR.  
SAM YANG CORPORATION POLYCARBONATE 3025N2 CLEAR.

1. GENERAL SPECIFICATIONS: BIVAR MOLDED COMPONENT SPECIFICATION BV00-E101.

STANDARD TOLERANCE (UNLESS OTHERWISE SPECIFIED)		 4 THOMAS, IRVINE, CA. 92618 TEL: (949) 951-8808 FAX: (949) 951-3974		
DECIMALS	ANGULAR			
.X ±.1	X° ±1°	 TITLE: LIGHT PIPE, 90° SURFACE MOUNT	PART NO: SLP-1	REVISION: C
.XX ±.01				
.XXX ±.005				
DESIGNED: Shane Irving	DATE: 11/23/98	CAGE CODE : 32559	SHEET # 1 OF 1	
CHECKED: R. Dienst	DATE: 08/14/00	CAD GENERATED DOCUMENT, DO NOT MEASURE DRAWING.		