



Austin Semiconductor, Inc.

# SRAM AS5LC512K8

## 512K x 8 SRAM

3.3 VOLT HIGH SPEED SRAM with  
CENTER POWER PINOUT

### AVAILABLE AS MILITARY SPECIFICATIONS

- MIL-STD-883 for Ceramic
- Extended Temperature Plastic (COTS)

### FEATURES

- Ultra High Speed Asynchronous Operation
- Fully Static, No Clocks
- Multiple center power and ground pins for improved noise immunity
- Easy memory expansion with CE\ and OE\ options
- All inputs and outputs are TTL-compatible
- Single +3.3V Power Supply +/- 0.3%
- Data Retention Functionality Testing
- Cost Efficient Plastic Packaging
- Extended Testing Over -55°C to +125°C for plastics

### OPTIONS

- Timing
  - 12ns access
  - 15ns access
  - 20ns access
- Operating Temperature Ranges
  - Military (-55°C to +125°C)
  - Industrial (-40°C to +85°C)

### MARKING

-12  
-15  
-20

XT  
IT

- Package(s)
 

Ceramic Flatpack	F	No. 307
Plastic SOJ (400 mils wide)	DJ	
Ceramic LCC	EC	No. 210
- 2V data retention/low power L

For more products and information  
please visit our web site at  
[www.austinsemiconductor.com](http://www.austinsemiconductor.com)

### PIN ASSIGNMENT

(Top View)

36-Pin PSOJ (DJ)  
36-Pin CLCC (EC)

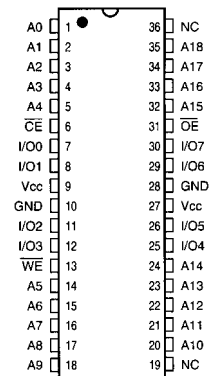

36-Pin Flat Pack (F)

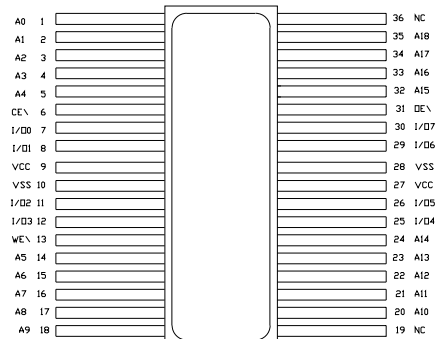

### GENERAL DESCRIPTION

The AS5LC512K8 is a 3.3V high speed SRAM. It offers flexibility in high-speed memory applications, with chip enable (CE\ and output enable (OE\)) capabilities. These features can place the outputs in High-Z for additional flexibility in system design.

Writing to these devices is accomplished when write enable (WE\ and CE\ inputs are both LOW. Reading is accomplished when WE\ remains HIGH and CE\ and OE\ go LOW.

As an option, the device can be supplied offering a reduced power standby mode, allowing system designers to meet low standby power requirements. This device operates from a single +3.3V power supply and all inputs and outputs are fully TTL-compatible.

The AS5LC512K8DJ offers the convenience and reliability of the AS5LC512K8 SRAM and has the cost advantage of a plastic encapsulation.



FUNCTIONAL BLOCK DIAGRAM

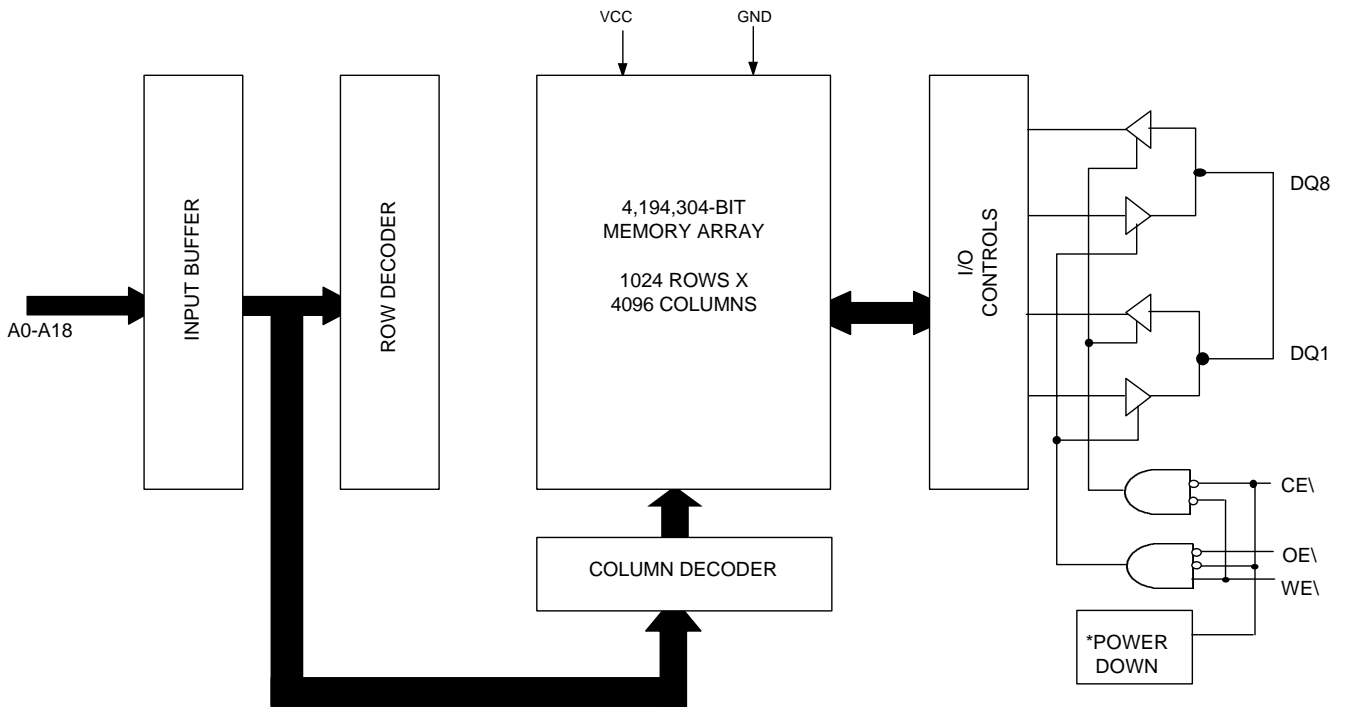

\*On the low voltage Data Retention option.

TRUTH TABLE

MODE	OE\	CE\	WE\	I/O	POWER
STANDBY	X	H	X	HIGH-Z	STANDBY
READ	L	L	H	Q	ACTIVE
NOT SELECTED	H	L	H	HIGH-Z	ACTIVE
WRITE	X	L	L	D	ACTIVE

X = Don't Care

PIN FUNCTIONS

A0 - A18	Address Inputs
WE\	Write Enable
CE\	Chip Enable
OE\	Output Enable
I/O <sub>0</sub> - I/O <sub>7</sub>	Data Inputs/Outputs
V <sub>CC</sub>	Power
V <sub>SS</sub>	Ground
NC	No Connection



**ABSOLUTE MAXIMUM RATINGS\***

Voltage on Vcc Supply Relative to Vss  
 Vcc .....-5V to 4.6V  
 Storage Temperature .....-65°C to +150°C  
 Short Circuit Output Current (per I/O).....20mA  
 Voltage on any Pin Relative to Vss.....-5V to 4.6V  
 Maximum Junction Temperature\*\* .....+150°C  
 Power Dissipation .....1W

\*Stresses greater than those listed under "Absolute Maximum Ratings" may cause permanent damage to the device. This is a stress rating only and functional operation of the device at these or any other conditions above those indicated in the operation section of this specification is not implied. Exposure to absolute maximum rating conditions for extended periods may affect reliability.

\*\* Junction temperature depends upon package type, cycle time, loading, ambient temperature and airflow, and humidity.

**ELECTRICAL CHARACTERISTICS AND RECOMMENDED DC OPERATING CONDITIONS**

(-55°C < T<sub>A</sub> < +125°C & -40°C < T<sub>A</sub> < +85°C ; Vcc = 3.3V +0.3%)

DESCRIPTION	CONDITIONS	SYM	MAX			UNITS	NOTES
			-12	-15	-20		
Power Supply Current: Operating	CE \ ≤ V <sub>IL</sub> ; Vcc = MAX f = MAX = 1/t <sub>RC</sub> Outputs Open	I <sub>CCSP</sub>	80	70	60	mA	3, 2
	"L" Version Only	I <sub>CCLP</sub>	60	50	40	mA	
Power Supply Current: Standby	CE \ ≥ V <sub>IH</sub> , All other inputs ≤ V <sub>IL</sub> , Vcc = MAX, f = 0, Outputs Open	I <sub>SBTSP</sub>	20	20	20	mA	
	"L" Version Only	I <sub>SBTLP</sub>	15	15	15	mA	
	CE \ ≥ Vcc -0.2V; Vcc = MAX V <sub>IN</sub> ≤ Vss +0.2V or V <sub>IN</sub> ≥ Vcc -0.2V; f = 0	I <sub>SBCSP</sub>	15	15	15	mA	
	"L" Version Only	I <sub>SBCLP</sub>	9	9	9	mA	

DESCRIPTION	CONDITIONS	SYM	MIN	MAX	UNITS	NOTES
Input High (Logic 1) Voltage		V <sub>IH</sub>	2.2	Vcc +0.3	V	1
Input Low (Logic 0) Voltage		V <sub>IL</sub>	-0.3	0.8	V	1
Input Leakage Current	0V ≤ V <sub>IN</sub> ≤ Vcc	I <sub>LI</sub>	-2	2	μA	
Output Leakage Current	Output(s) Disabled 0V ≤ V <sub>OUT</sub> ≤ Vcc	I <sub>LO</sub>	-2	2	μA	
Output High Voltage	I <sub>OH</sub> = -4.0 mA	V <sub>OH</sub>	2.4	---	V	1
Output Low Voltage	I <sub>OL</sub> = 8 mA	V <sub>OL</sub>	---	0.5	V	1

**CAPACITANCE**

PARAMETER	CONDITIONS	SYMBOL	MAX	UNITS	NOTES
Input Capacitance	T <sub>A</sub> = 25°C, f = 1MHz V <sub>IN</sub> = 0	C <sub>I</sub>	9	pF	4
Output Capacitance		C <sub>O</sub>	6	pF	4



Austin Semiconductor, Inc.

**SRAM  
AS5LC512K8**

**ELECTRICAL CHARACTERISTICS AND RECOMMENDED AC OPERATING CONDITIONS**

( $-55^{\circ}\text{C} < T_A < +125^{\circ}\text{C}$  or  $-40^{\circ}\text{C}$  to  $+85^{\circ}\text{C}$ ;  $V_{CC} = 3.3\text{V} \pm 0.3\%$ )

DESCRIPTION	SYM	-12		-15		-20		UNITS	NOTES
		MIN	MAX	MIN	MAX	MIN	MAX		
<b>READ CYCLE</b>									
Read Cycle Time	$t_{RC}$	12		15		20		ns	
Address Access Time	$t_{AA}$		12		15		20	ns	
Chip Enable Access Time	$t_{ACE}$		12		15		20	ns	
Output Hold From Address Change	$t_{OH}$	2		2		2		ns	
Chip Enable to Output in Low-Z	$t_{LZCE}$	2		2		2		ns	4, 6, 7
Chip Disable to Output in High-Z	$t_{HZCE}$		6		7		8	ns	4, 6, 7
Output Enable Access Time	$t_{AOE}$		6		7		8	ns	
Output Enable to Output in Low-Z	$t_{LZOE}$	0		0		0		ns	4, 6, 7
Output Disable to Output in High-Z	$t_{HZOE}$		6		7		8	ns	4, 6, 7
<b>WRITE CYCLE</b>									
WRITE Cycle Time	$t_{WC}$	12		15		20		ns	
Chip Enable to End of Write	$t_{CW}$	8		10		12		ns	
Address Valid to End of Write	$t_{AW}$	8		10		12		ns	
Address Setup Time	$t_{AS}$	0		0		0		ns	
Address Hold From End of Write	$t_{AH}$	0		0		0		ns	
WRITE Pulse Width	$t_{WP}$	10		12		15		ns	
Data Setup Time	$t_{DS}$	6		7		8		ns	
Data Hold Time	$t_{DH}$	1		1		1		ns	
Write Disable to Output in Low-Z	$t_{LZWE}$	2		2		2		ns	4, 6, 7
Write Enable to Output in High-Z	$t_{HZWE}$	5		6		7		ns	4, 6, 7



**AC TEST CONDITIONS**

Input pulse levels .....	V <sub>SS</sub> to 3.0V
Input rise and fall times .....	3ns
Input timing reference levels .....	1.5V
Output reference levels .....	1.5V
Output load .....	See Figures 1 and 2

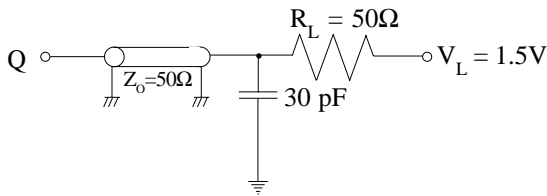

**Fig. 1 Output Load Equivalent**

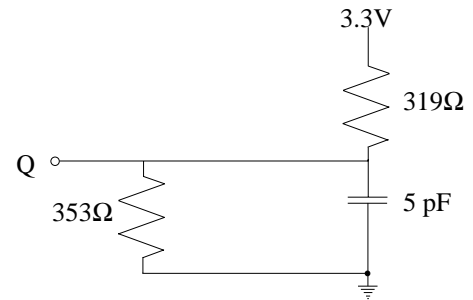

**Fig. 2 Output Load Equivalent**

**NOTES**

- All voltages referenced to V<sub>SS</sub> (GND).
- I<sub>CC</sub> limit shown is for absolute worst case switching of ADDR, ADDR\, ADDR, etc.
- I<sub>CC</sub> is dependent on output loading and cycle rates.
- This parameter is guaranteed but not tested.
- Test conditions as specified with the output loading as shown in Fig. 1 unless otherwise noted.
- 'LZCE, 'LZWE, 'LZOE, 'HZCE, 'HZOE and 'HZWE are specified with CL = 5pF as in Fig. 2. Transition is measured ±200mV from steady state voltage.
- At any given temperature and voltage condition, 'HZCE is less than 'LZCE, and 'HZWE is less than 'LZWE.
- WE\ is HIGH for READ cycle.
- Device is continuously selected. Chip enables and output enables are held in their active state.
- Address valid prior to, or coincident with, latest occurring chip enable.
- 'RC = Read Cycle Time.
- Chip enable and write enable can initiate and terminate a WRITE cycle.
- Output enable (OE) is inactive (HIGH).
- Output enable (OE) is active (LOW).
- ASI does not warrant functionality nor reliability of any product in which the junction temperature exceeds 150°C. Care should be taken to limit power to acceptable levels.

**DATA RETENTION ELECTRICAL CHARACTERISTICS (L Version Only)**

DESCRIPTION	CONDITIONS	SYM	MIN	MAX	UNITS	NOTES
V <sub>CC</sub> for Retention Data	CE\ > V <sub>CC</sub> -0.2V V <sub>IN</sub> > V <sub>CC</sub> -0.2 or 0.2V	V <sub>DR</sub>	2		V	
Data Retention Current	V <sub>CC</sub> = 2.0V	I <sub>CCDR</sub>		6.5	mA	
Chip Deselect to Data		t <sub>CDR</sub>	0		ns	4
Operation Recovery Time		t <sub>R</sub>	20		ms	4, 11



LOW  $V_{CC}$  DATA RETENTION WAVEFORM

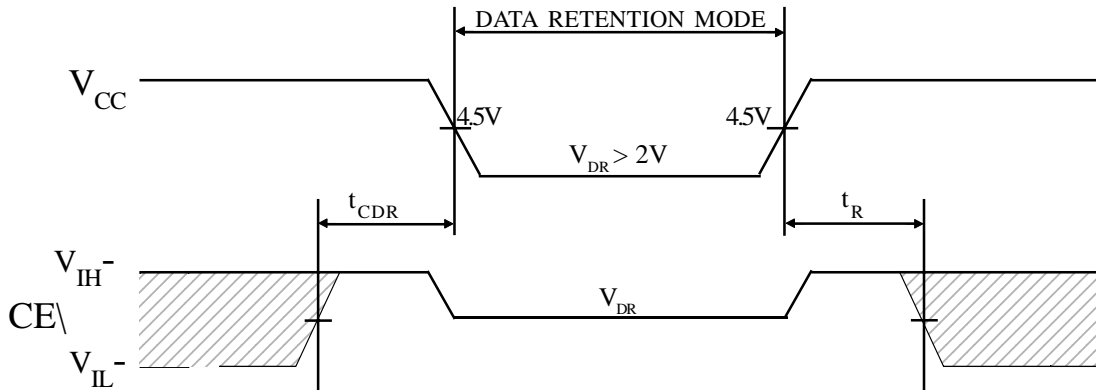

READ CYCLE NO. 1<sup>1,2</sup>  
(Address Controlled,  $CE \setminus = OE \setminus = V_{IL}$ ,  $WE \setminus = V_{IH}$ )

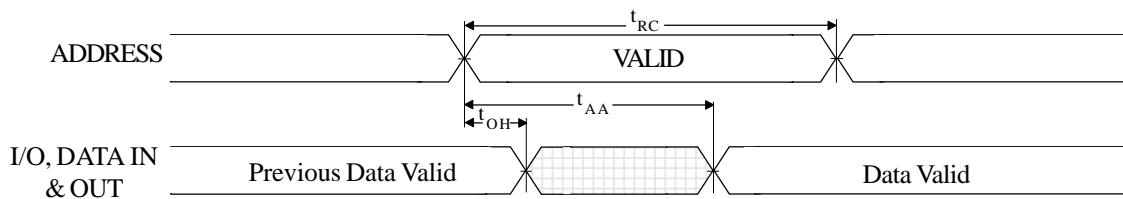

READ CYCLE NO. 2  
( $WE \setminus = V_{IH}$ )

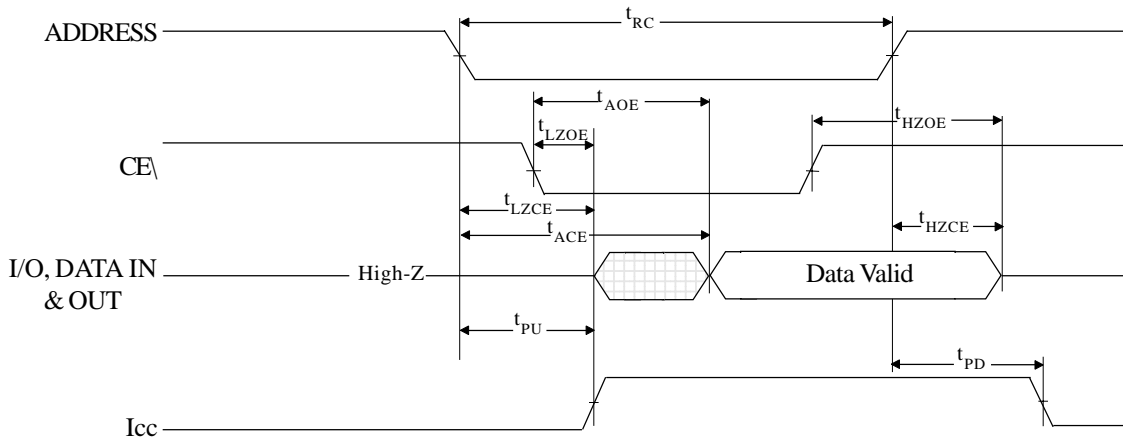

NOTES:

1.  $WE \setminus$  is HIGH for READ cycle.
2. Device is continuously selected. Chip enables and output enables are held in their active state.

 Don't Care  
 Undefined



**WRITE CYCLE NO. 1<sup>1</sup>**  
(CE Controlled)

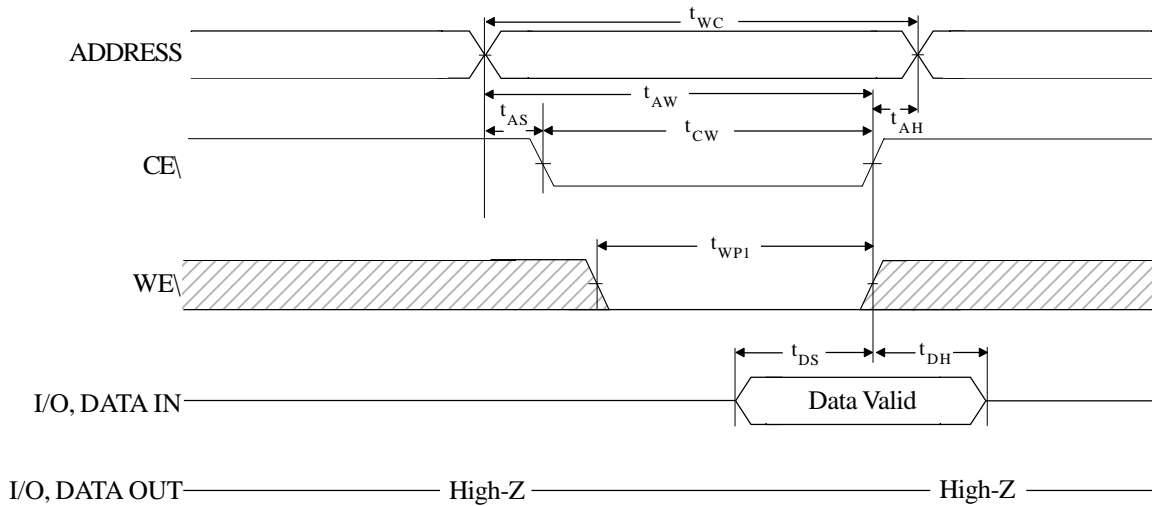

**WRITE CYCLE NO. 2<sup>1,2</sup>**  
(Write Enabled Controlled)

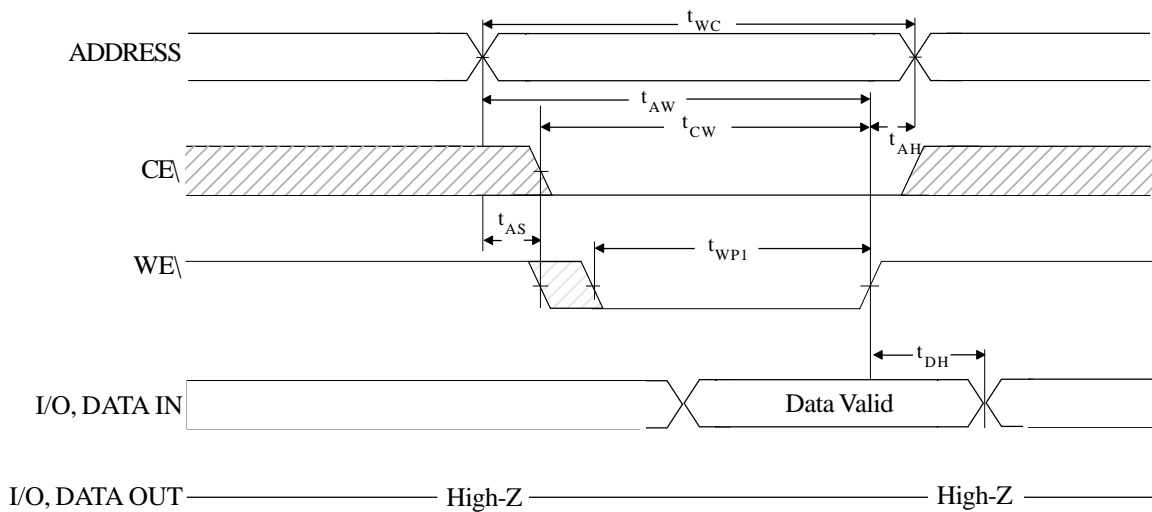

**NOTES:**

1. Chip enable and write enable can initiate and terminate a WRITE cycle.
2. Output enable (OE) is inactive (HIGH).



**WRITE CYCLE NO. 3<sup>1, 2, 3</sup>**  
(WE Controlled)

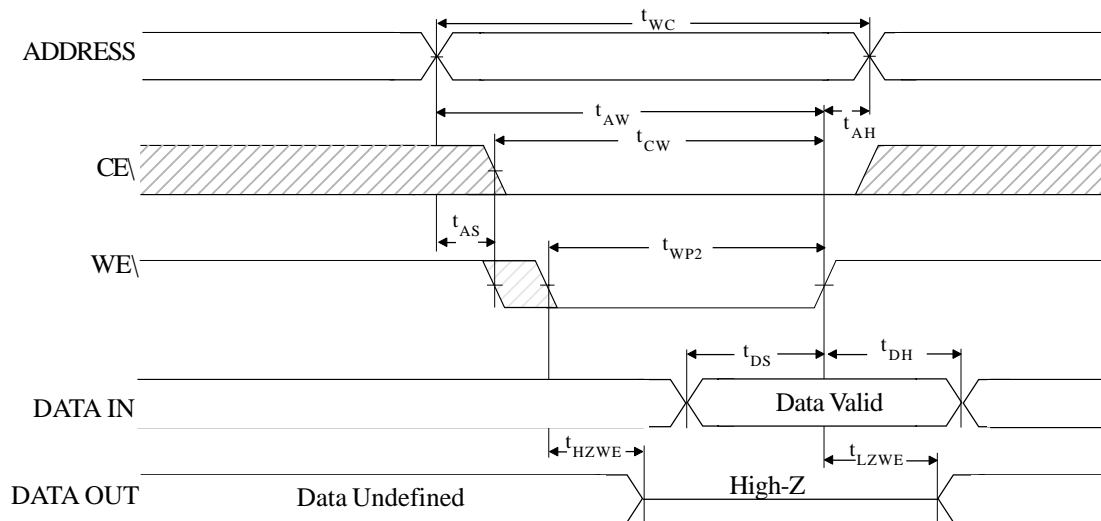

**NOTES:**

1. At any given temperature and voltage condition,  $t_{HZCE}$  is less than  $t_{LZCE}$  and  $t_{HZWE}$  is less than  $t_{LZWE}$ .
2. Chip enable and write enable can initiate and terminate a WRITE cycle.
3. Output enable (OE) is active (LOW).





### MECHANICAL DEFINITIONS\*

ASI Case #307 (Package Designator F)

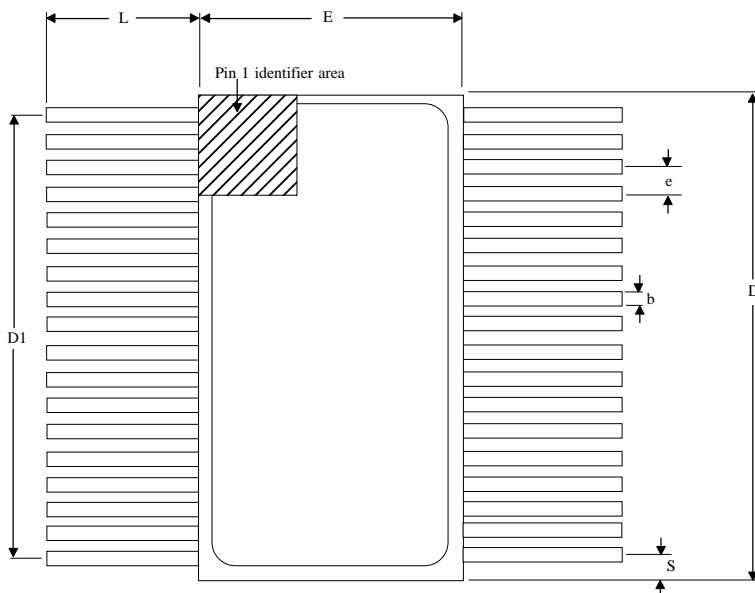

Top View

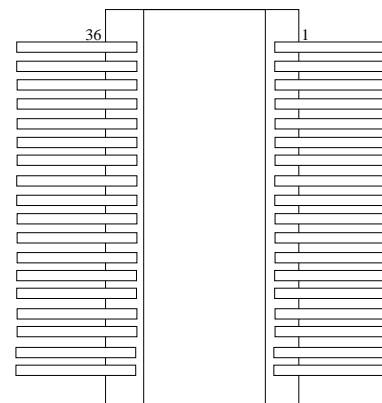

Bottom View

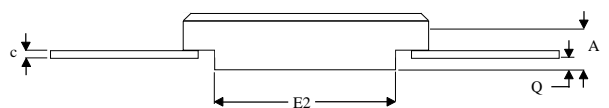

SYMBOL	ASI SPECIFICATIONS	
	MIN	MAX
A	0.096	0.125
b	0.015	0.022
c	0.003	0.009
D	0.910	0.930
D1	0.840	0.860
E	0.505	0.515
E2	0.385	0.397
e	0.050 BSC	
L	0.250	0.370
Q	0.020	0.045

\*All measurements are in inches.



### MECHANICAL DEFINITIONS\*

Package Designator DJ

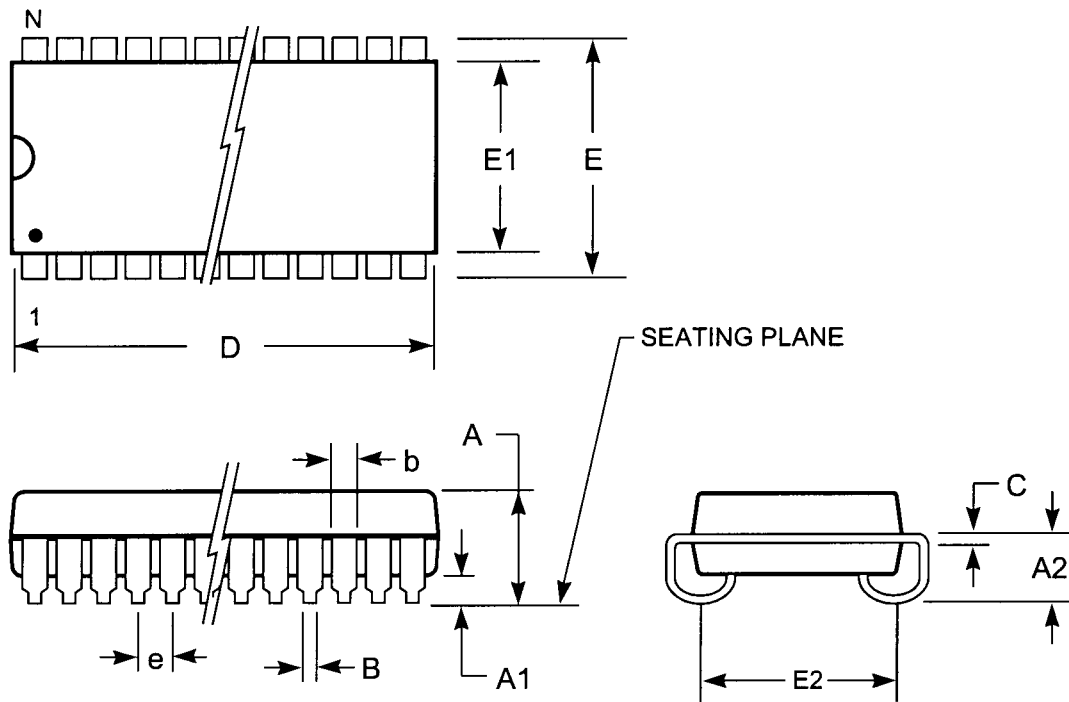

SYMBOL	ASI SPECIFICATIONS	
	MIN	MAX
A	0.128	0.148
A1	0.025	---
A2	0.082	---
B	0.015	0.020
b	0.026	0.032
C	0.007	0.013
D	0.920	0.930
E	0.435	0.445
E1	0.395	0.405
E2	0.370 BSC	
e	0.050 BSC	

\*All measurements are in inches.



**MECHANICAL DEFINITIONS\***

**ASI Case #210 (Package Designator EC)**

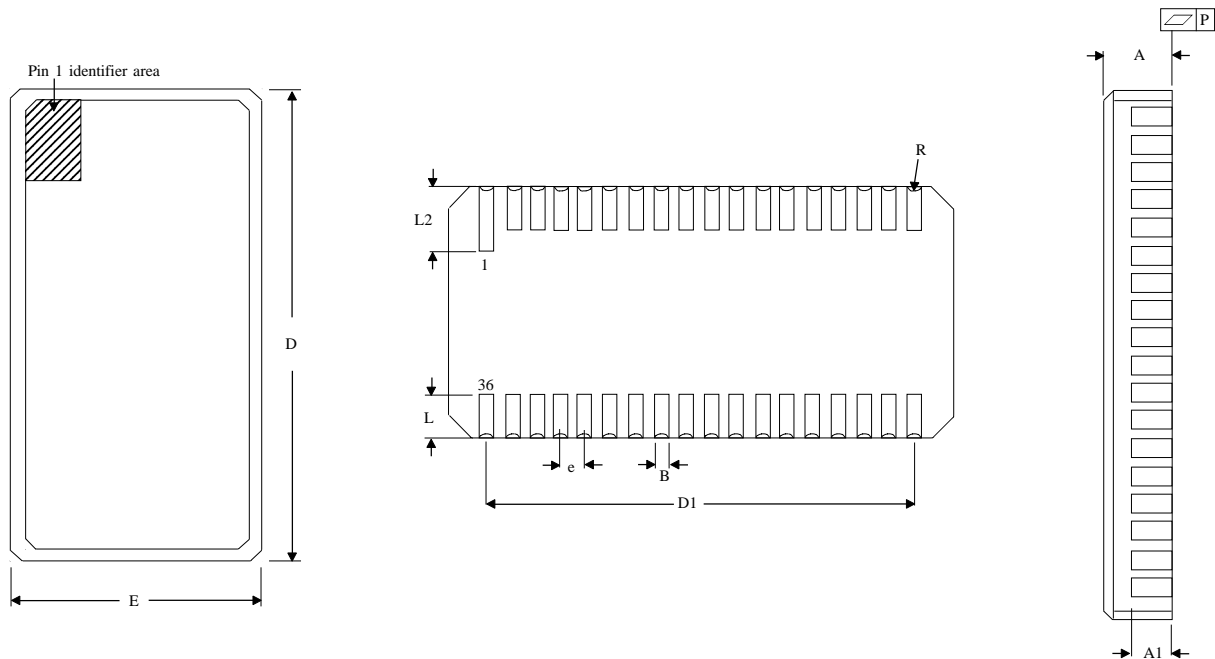

SYMBOL	ASI SPECIFICATIONS	
	MIN	MAX
A	0.080	0.100
A1	0.054	0.066
B	0.022	0.028
D	0.910	0.930
D1	0.840	0.860
E	0.445	0.460
e	0.050 BSC	
L	0.100 TYP	
L2	0.115	0.135
P	---	0.006
R	0.009 TYP	

\*All measurements are in inches.



## ORDERING INFORMATION

EXAMPLE: AS5LC512K8F-12L/XT

Device Number	Package Type	Speed ns	Options**	Process
AS5LC512K8	F	-12	L	/*
AS5LC512K8	F	-15	L	/*
AS5LC512K8	F	-20	L	/*

EXAMPLE: AS5LC512K8DJ-20L/883C

Device Number	Package Type	Speed ns	Options**	Process
AS5LC512K8	DJ	-12	L	/*
AS5LC512K8	DJ	-15	L	/*
AS5LC512K8	DJ	-20	L	/*

EXAMPLE: AS5LC512K8EC-15L/IT

Device Number	Package Type	Speed ns	Options**	Process
AS5LC512K8	EC	-12	L	/*
AS5LC512K8	EC	-15	L	/*
AS5LC512K8	EC	-20	L	/*

### \*AVAILABLE PROCESSES

IT = Industrial Temperature Range                      -40°C to +85°C  
XT = Extended Temperature Range                      -55°C to +125°C  
883C = Full Military Processing<sup>1</sup>                      -55°C to +125°C

### \*\*OPTIONS DEFINITIONS

L = 2V Data Retention / Low Power

**NOTES:** 1. 883C process available with ceramic packaging only.