

CCD area image sensor **S8980, S8981-02**

Front-illuminated FFT-CCDs for X-ray imaging



S8980 is an FFT-CCD image sensor ideal for intra-oral X-ray imaging in dental diagnosis. S8980 has 1.5 mega (1500 × 1000) pixels each of which is 20 × 20 μm. The fiber optic plate (FOP) used as an input window is as thin as 1.5 mm but highly resistant to X-ray irradiation, making S8980 very reliable even over a long-term operation. The scintillator coated on the FOP is optimized to have high X-ray sensitivity and high resolution (20 Lp/mm).

S8981-02 is an easy-to-use X-ray imaging module using S8980, with added functions such as a cable assembly and X-ray trigger circuit. S8981-02 is advanced type for S8981 and adapted both AC and DC X-ray sources.

Features

- Sensor has X-ray monitoring photodiode
- Compactness
5.1 mm thickness excluding I/O connector part
- High dynamic range: 12 bit
- Long-term stability
For use under 100,000 shots
(60 kVp, 30 mR X-ray irradiation)
- Resolution: 20 Lp/mm
- 1500 (H) × 1000 (V) pixel format
- Pixel size: 20 × 20 μm
- Coupled with FOS for X-ray imaging
- 100 % fill factor
- Low dark signal
- Low readout noise
- MPP operation
- AC/DC X-ray source adapted

Applications

- General X-ray imaging
- Non-destructive inspection
- Intra-oral X-ray imaging in dental diagnosis

■ Selection guide

Type No.	Cooling	Number of total pixels	Number of active pixels	Active area [mm (H) × mm (V)]
S8980	Non-cooled	1508 × 1002	1500 × 1000	30 × 20
S8981-02				

■ General ratings

Parameter	S8980	S8981-02
CCD structure	Full frame transfer	
Fill factor	100 %	
Number of active pixels	1500 (H) × 1000 (V)	
Pixel size	20 (H) × 20 (V) μm	
Active area	30 (H) × 20 (V) mm	
Vertical clock phase	2 phase	
Horizontal clock phase	2 phase	
Output circuit	Emitter follower without load resistance	
Dimensional outline	35.5 (H) × 23.2 (V) mm	38.7 (H) × 26.3 (V) mm
Reliability	100,000 shots at 60 kVp, 30 m Roentgen	
Window	Scintillator on 1.5 mm FOP	
Other	MPP mode (low dark current operation), module (S8981-02)	

■ Absolute maximum ratings (Ta=25 °C)

Parameter	Symbol	Min.	Typ.	Max.	Unit
Storage temperature	Tstg	-20	-	+70	°C
Operating temperature	Topr	0	-	+40	°C
OD voltage	VOD	-0.5	-	+20	V
RD voltage	VRD	-0.5	-	+18	V
SG voltage	VSG	-15	-	+15	V
OG voltage	VOG	-15	-	+15	V
RG voltage	VRG	-15	-	+15	V
TG voltage	VTG	-15	-	+15	V
Vertical clock voltage	VP1V, VP2V	-15	-	+15	V
Horizontal clock voltage	VP1H, VP2H	-15	-	+15	V
Vcc voltage	Vcc	0	-	+7	V

■ Operating conditions (MPP mode, Ta=25 °C)

Parameter	Symbol	Min.	Typ.	Max.	Unit	
Output transistor drain voltage	VOD	12	15	-	V	
Reset drain voltage	VRD	12	13	14	V	
Output gate voltage	VOG	-0.5	2	5	V	
Substrate voltage	Vss	-	0	-	V	
Vertical shift register clock voltage	High	VP1VH, VP2VH	0	3	6	V
	Low	VP1VL, VP2VL	-9	-8	-7	V
Horizontal shift register clock voltage	High	VP1HH, VP2HH	0	3	6	V
	Low	VP1HL, VP2HL	-9	-8	-7	V
Summing gate voltage	High	VsGH	0	3	6	V
	Low	VsGL	-9	-8	-7	V
Reset gate voltage	High	VRGH	0	3	6	V
	Low	VRGL	-9	-8	-7	V
Transfer gate voltage	High	VTGH	0	3	6	V
	Low	VTGL	-9	-8	-7	V
+5 V power supply voltage	Vcc	4.75	5	5.25	V	

■ Electrical characteristics (Ta=25 °C)

Parameter	Symbol	Remark	Min.	Typ.	Max.	Unit
Signal output frequency	fc	*1	-	1	5	MHz
Vertical shift register capacitance	CP1V, CP2V		-	60,000	-	pF
Horizontal shift register capacitance	S8980	CP1H, CP2H	-	350	-	pF
	S8981-02		-	550	-	
Summing gate capacitance	S8980	CsG	-	20	-	pF
	S8981-02		-	220	-	
Reset gate capacitance	S8980	CRG	-	20	-	pF
	S8981-02		-	220	-	
Transfer gate capacitance	S8980	CTG	-	250	-	pF
	S8981-02		-	450	-	
Charge transfer efficiency	CTE	*2	0.99995	0.99998	-	-
DC output level	Vout	*3	5	8	11	V
Output impedance	Zo	*3	-	500	-	Ω
Power dissipation	P	*3 *4	-	75	-	mW
+5 V power supply current	S8980	Icc	-	1	-	mA
	S8981-02		-	2	-	

*1: S8980 only. In case of S8981-02, maximum frequency is strongly depend on peripheral circuit and cable length.

*2: Measured at half of the full well capacity. CTE is defined per pixel.

*3: VOD=15 V

*4: Power dissipation of the on-chip amplifier.

■ Electrical and optical characteristics (Ta=25 °C, unless otherwise noted, VOD=15 V)

Parameter		Symbol	Remark	Min.	Typ.	Max.	Unit
Full well capacity	Vertical	Fw		100	200	-	ke ⁻
	Horizontal			-	300	-	
	Summing			-	600	-	
CCD node sensitivity		Sv	*5	1.0	1.4	-	μV/e ⁻
Dark current (MPP mode)		DS	*6	-	250	2,500	e ⁻ /pixel/s
Readout noise		Nr	*7	-	60	-	e ⁻ rms
Dynamic range		DR	*8	-	3333	-	-
X-ray response non-uniformity		XRNU	*9, *10	-	±10	±30	%
Blemish *11	Point defects *12	White spots	-	-	-	20	-
		Black spots		-	-	20	
	Cluster defects	*13		-	-	3	
	Column defects	*14		-	-	1	
X-ray resolution		ΔR	*9	15	20	-	Lp/mm

*5: VOD=15 V, RL(load resistance of emitter follower)=1 kΩ.

*6: Dark signal doubles for every 5 to 7 °C.

*7: -40 °C, operating frequency is 1 MHz.

*8: Dynamic range = Full well capacity / Readout noise

*9: X-ray irradiation of 60 kVp, measured at half of the full well capacity.

*10: XRNU (%) = Noise / Signal × 100

Noise: Fixed pattern noise (peak to peak)

In the range that excludes 5 pixels from edges to the center at every position.

*11: Refer to “Characteristics and use of FFT-CCD area image sensor” of technical information.

*12: White spots > 10 times of Max. Dark signal (2,500 e⁻/pixel/s).

Black spots > 50 % reduction in response relative to adjacent pixels, measured at half of the full well capacity.

*13: continuous 2 to 9 point defects.

*14: continuous > 10 point defects.

■ Device structure

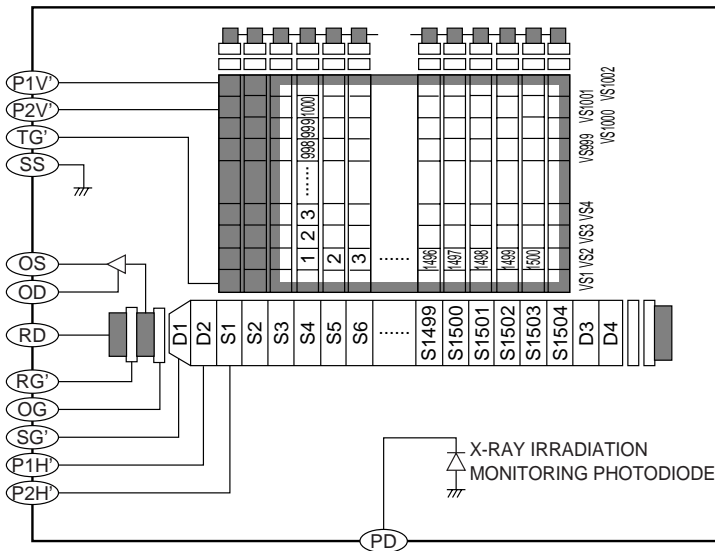

KMPDC0163EA

■ Pixel format

← Left Horizontal Direction → Right						
Blank	Optical black	Isolation	Effective	Isolation	Optical black	Blank
2	2	1	1500	1	0	2

Top ← Vertical direction → Bottom		
Isolation	Effective	Isolation
1	1000	1

On-board circuit

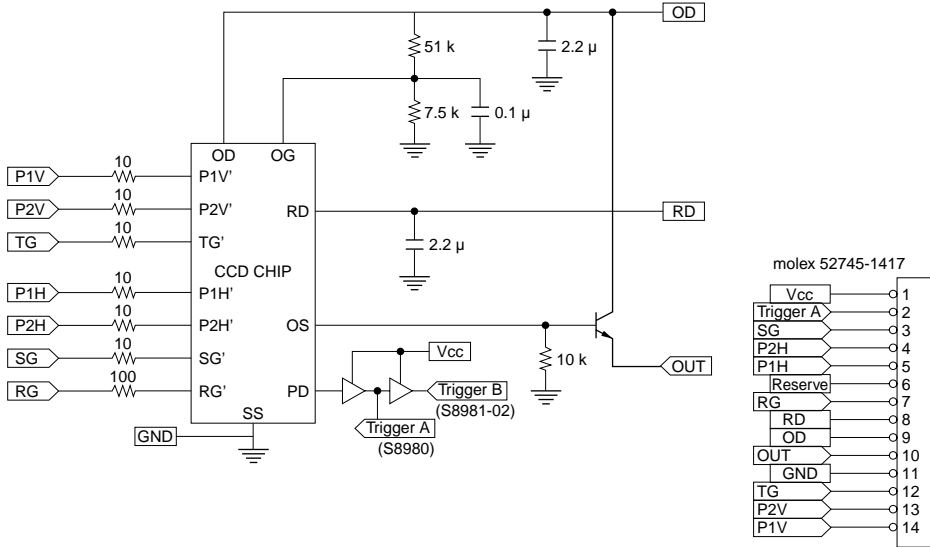

KMPDC0214EB

Timing chart

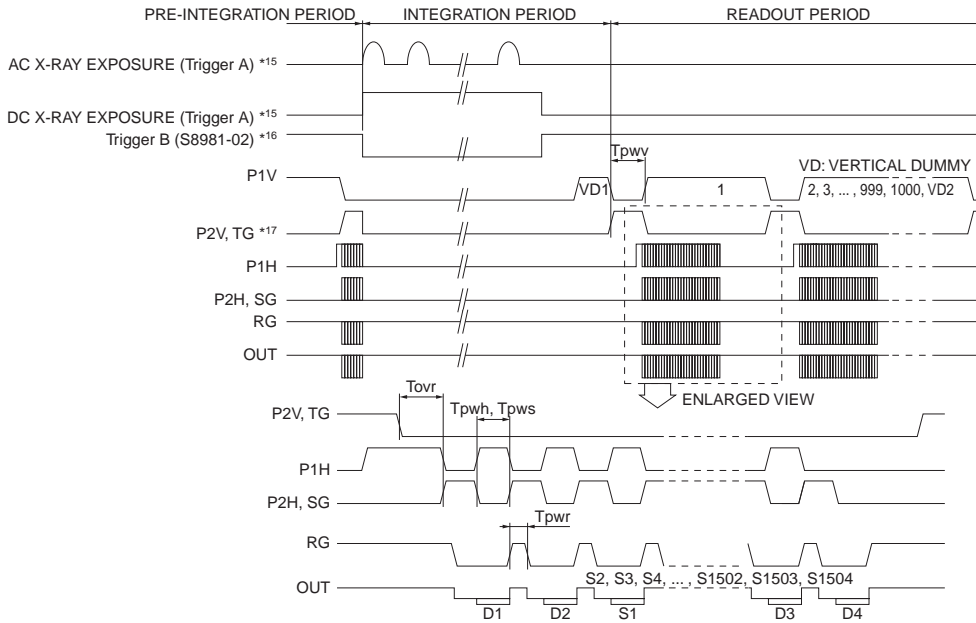

*15: Trigger A (S8980) is the same as AC/DC X-ray exposure form.

*16: Low active trigger pulse

*17: TG terminal can be short-circuited to P2V terminal.

KMPDC0215EA

Parameter	Symbol	Remark	Min.	Typ.	Max.	Unit	
P1V, P2V, TG	Pulse width	tpwv	*18	30	60	-	μs
	Rise and fall time	tprv, tpfv		200	-	-	ns
P1H, P2H	Pulse width	tpwh		100	500	-	ns
	Rise and fall time	tprh, tpfh	*18	5	-	-	ns
	Duty ratio			-	50	-	%
SG	Pulse width	tpws		100	500	-	ns
	Rise and fall time	tprs, tpfS		3	-	-	ns
	Duty ratio			-	50	-	%
RG	Pulse width	tpwr		10	50	-	ns
	Rise and fall time	tprr, tprf		3	-	-	ns
TG-P1H	Overlap time	tovr		18	36	-	μs

*18: Symmetrical pulses should be overlapped at 50 % of maximum amplitude.

CCD area image sensor S8980, S8981-02

Dimensional outlines (unit: mm)

S8980

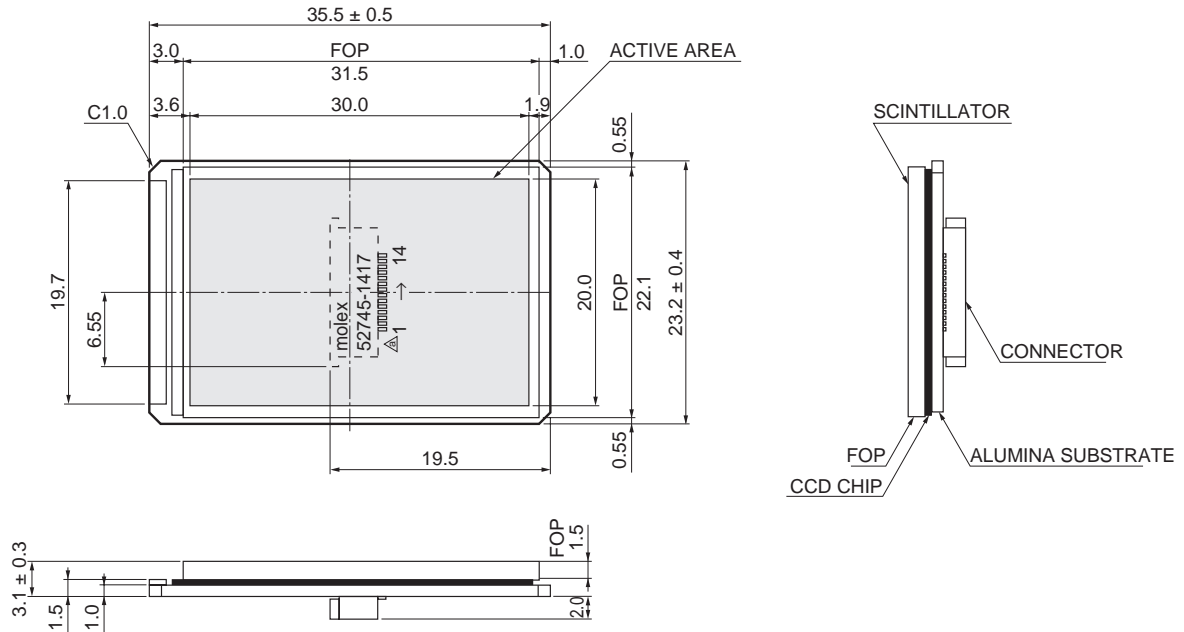

KMPDA0169EB

Pin connections (Connector on CCD package)

Pin No.	Symbol	Description	Remark
1	Vcc	Analog power +5 V	
2	Trigger A	Trigger A output	
3	SG	Summing gate	
4	P2H	CCD horizontal register clock-2	
5	P1H	CCD horizontal register clock-1	
6	Reserve		Should be opened
7	RG	Reset gate	
8	RD	Reset drain	
9	OD	Output transistor drain	
10	OUT	Signal output	
11	GND	Ground	
12	TG	Transfer gate	
13	P2V	CCD vertical register clock-2	
14	P1V	CCD vertical register clock-1	

S8981-02

● Entire view

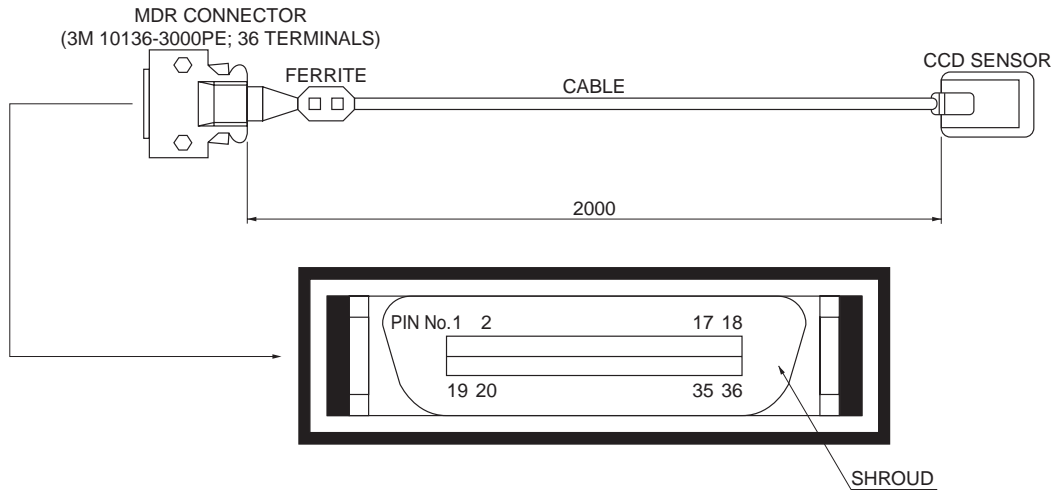

KMPDA0189EA

* The shield of cable and the shroud of MDR connector are electrically connected each other. They are short-circuited, so there is no electrical contact to any other positions.

● CCD sensor

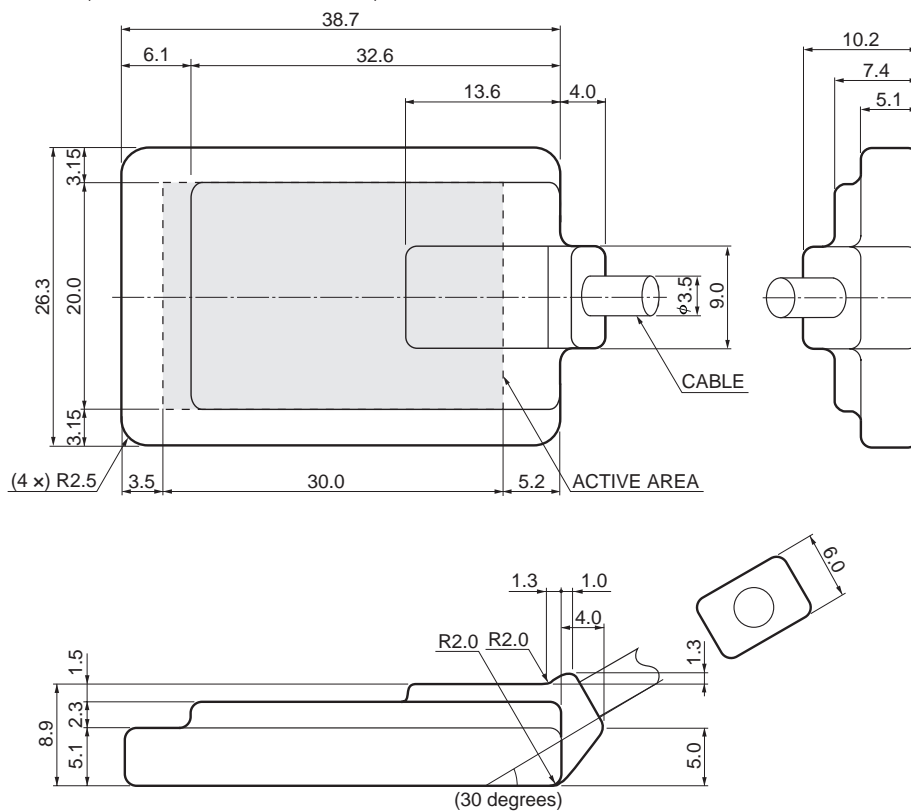

KMPDA0190EA

■ Pin connections

Pin No.	Symbol	Description	Remark
1	GND	Ground	
2	Vcc	+5 V power supply	
3	SG	Summing gate	Same timing as P2H
4	Trigger B	Trigger B output	
5	RG	Reset gate	
6	NC		
7	Reserve		Should be opened
8	NC		
9	RD	Reset drain	
10	NC		
11	OD	Output transistor drain	
12	NC		
13	OUT	Sensor output	
14	NC		
15	GND	Ground	
16	NC		
17	P1V	CCD vertical register clock-1	
18	Reserve		Should be opened
19	Reserve		Should be opened
20	P2H	CCD horizontal register clock-2	
21	NC		
22	P1H	CCD horizontal register clock-1	
23	NC		
24	GND	Ground	
25	NC		
26	RD	Reset drain	
27	NC		
28	OD	Output transistor drain	
29	NC		
30	GND	Ground	
31	NC		
32	OUT	Sensor output	
33	NC		
34	P2V	CCD vertical register clock-2	
35	NC		
36	TG	Transfer gate	Same timing as P2V

■ Precautions for use (Electrostatic countermeasures)

- *Handle these sensors with bare hands or wearing cotton gloves. In addition, wear anti-static clothing or use a wrist band with an earth ring, in order to prevent electrostatic damage due to electrical charges from friction.
- *Avoid directly placing these sensors on a work-desk or work-bench that may carry an electrostatic charge.
- *Provide ground lines or ground connection with the work-floor, work-desk and work-bench to allow static electricity to discharge.
- *Ground the tools used to handle these sensors, such as tweezers and soldering irons.

It is not always necessary to provide all the electrostatic measures stated above. Implement these measures according to the amount of damage that occurs.