

WORLDWIDE

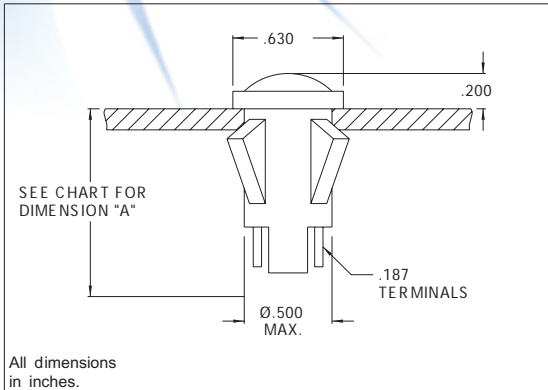

1030QD, 1031QD, 1032QD and 1033QD Series Non-Relampable Neon Indicator Lights

DESCRIPTION AND FEATURES



Mounting: Will snap-fit into Ø.500/.505 hole in panels .020/.100 thick. Push-on speednut SN0461 also available.
Mounting hole pattern on page SP2.

Terminals: Quick-connect, tinned brass

Lens: Polycarbonate

Bezel: Polished stainless steel.
For black finish add "X" after the series letter(s).

Housing: White Nylon

Lens Color	Neon	
	Model No. (105-125VAC)	Model No. (208-250VAC)
Red	1030QD1	1031Q D1
Amber	1030QD3	1031QD 3
White	1030QD4	1031QD 4
Green	1032QD5*	1033QD 5*
Lamp used	C2A+R esistor	

* Incorporates G2B lamp and resistor.
Underwriters Laboratories (UL) File No. E20325
Canadian Standards Association (CSA) File No. LR13346

10300D, 10310D, 10320D and 10330D Series
Non-Relampable Neon Indicator Lights



America:
CML Innovative Technologies, Inc.
147 Central Avenue
Hackensack, NJ 07601 -USA
Tel: 1-201-489-8989
Fax: 1-201-489-6911
e-mail: americas@cml-it.com

Europe:
CML Technologies GmbH & Co. KG
Robert-Bunsen-Str. 1
67098 Bad Dürkheim - GERMANY
Tel: +49 (0)6322 9567-0
Fax: +49 (0)6322 9567-88
e-mail: europe@cml-it.com

Asia:
CML Innovative Technologies, Inc.
61 Aida Street
Singapore 459975
Tel: (65)9630-5003
e-mail: asia@cml-it.com