

**MARKETING SALES DRAWING**  
**DIMENSIONS IN INCHES - DO NOT SCALE THIS DRAWING**

Electrical Testing  
 per Tusonix standard  
 test plans and Mil-Std-202  
 Test Methods.

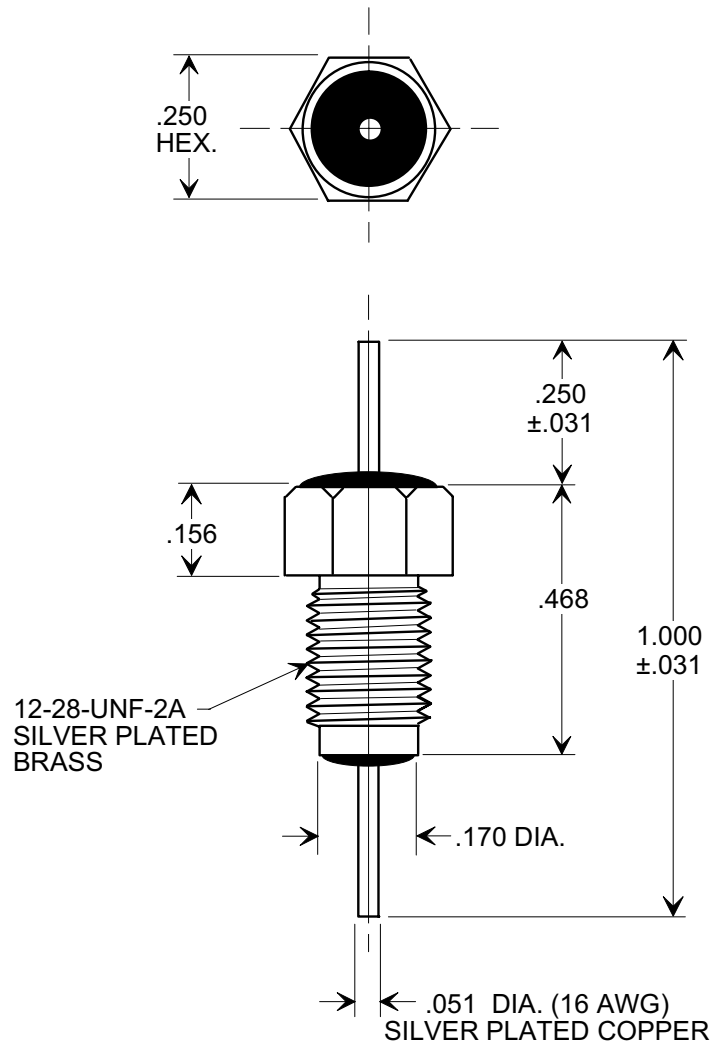
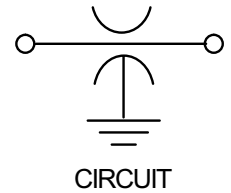
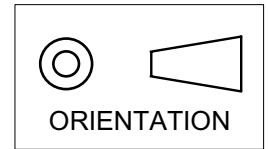

12-28-UNF-2A  
 SILVER PLATED  
 BRASS

NOTE:  
 SUPPLIED WITH SILVER PLATED  
 HEX NUT AND INTERNAL TOOTH  
 LOCK WASHER

ORDERING INFORMATION

TUSONIX PART NO.	2499-003-X5U0-102P
STYLE NO.	2499-003
VALUE	1000 pF
VALUE TOL.	- 0% + 100%
TEMP. COEF.	X5U
RATING	500 WVDC
OPERATING RANGE	-55° TO +85°C
TO TUSONIX SPEC. UNLESS STATED OTHERWISE	

X-2015 Rev-0 REVISION RECORD Original Release C.O. 20000508-4-01	0	--TOLERANCES-- Unless Otherwise Specified  DECIMAL ± .015  ANGLES ±	Title <b>BUSHING TYPE                  FEED-THRU                  CAPACITOR</b>	
	<b>TUSONIX</b> TUCSON, ARIZONA		Drawn L.E. 05-09-00 Scale 3X	
			Approved T.C. 05-09-00	
	<b>A</b>		<b>2499-003-X5U0-102 P</b>	