

### POWER MANAGEMENT

#### Description

The SC4608 is a voltage mode step down (buck) regulator controller that provides accurate high efficiency power conversion from an input supply range of 2.7V to 5.5V. A high level of integration reduces external component count, and makes it suitable for low voltage applications where cost, size and efficiency are critical. The SC4608 is capable of producing an output voltage as low as 0.5V. It's frequency of operation is programmable to 1MHz.

The SC4608 drives external, N-channel MOSFETs with a peak gate current of 1A. A non-overlap protection is provided for the gate drive signals to prevent shoot through of the MOSFET pair. The SC4608 features lossless current sensing of the voltage drop across the drain to source resistance of the high side MOSFET during its conduction period.

The quiescent supply current in sleep mode is typically lower than 1 $\mu$ A. A external soft start is provided to prevent output voltage overshoot during start-up.

The SC4608 is an ideal choice for converting 3.3V, 5V or other low input supply voltages. It's available in 16 pin MLP package.

#### Features

- ◆ Asynchronous start up
- ◆ Programmable switching frequency up to 1MHz
- ◆ BiCMOS voltage mode PWM controller
- ◆ 2.7V to 5.5V input voltage range
- ◆ Output voltage as low as 0.5V
- ◆ +/-1% reference accuracy
- ◆ Sleep mode (I<sub>cc</sub> = 1 $\mu$ A max)
- ◆ Adjustable lossless short circuit current limiting
- ◆ Combination pulse by pulse & hiccup mode current limit
- ◆ High efficiency synchronous switching
- ◆ 1A peak current driver
- ◆ External soft start
- ◆ Power good signal
- ◆ 16-pin MLP Lead-free package. This product is fully WEEE and RoHS compliant

#### Applications

- ◆ Distributed power architecture
- ◆ Servers/workstations
- ◆ Local microprocessor core power supplies
- ◆ DSP and I/O power supplies
- ◆ Battery-powered applications
- ◆ Telecommunications equipment
- ◆ Data processing applications

#### Typical Application Circuit

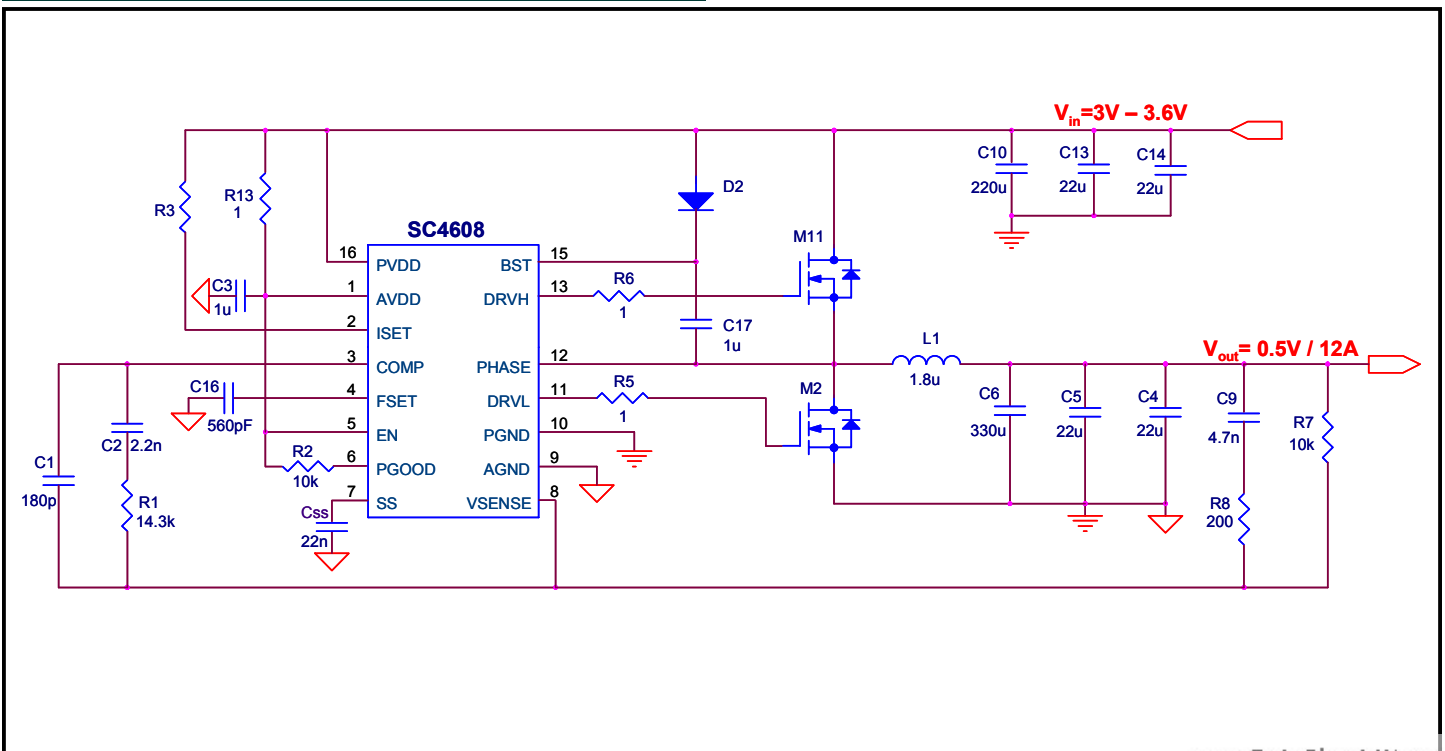

**POWER MANAGEMENT**
**Absolute Maximum Ratings**

Exceeding the specifications below may result in permanent damage to the device, or device malfunction. Operation outside of the parameters specified in the Electrical Characteristics section is not implied.

Parameter	Symbol	Maximum	Units
Analog Supply Voltage ( $AV_{DD}$ )		6	V
Power Supply Voltage ( $PV_{DD}$ )		$AV_{DD} \pm 0.3$	V
PGND		$\pm 0.3$	V
Output Drivers (DRVH, DRVL) Currents Continuous		$\pm 0.25$	A
Peak		$\pm 1.00$	A
Inputs (VSENSE, COMP, FSET, ISET, SS)		-0.3 to $AV_{DD} + 0.3$	V
BST		$PV_{DD} + 6$	V
PHASE		-0.3 to $PV_{DD} + 0.3$	V
PHASE Pulse $t_{pulse} < 50ns$		-2 to $PV_{DD} + 1$	V
Storage Temperature Range	$T_{STG}$	-65 to +150	°C
Maximum Junction Temperature	$T_J$	+150	°C
Peak IR Reflow Temperature, 10 - 40s	$T_{PKG}$	260	°C
ESD Rating (Human Body Model)	ESD	2	kV

All voltages with respect to AGND. Currents are positive into, negative out of the specified terminal.

**Electrical Characteristics**

Unless otherwise specified,  $AV_{DD} = 3.3V$ ,  $AV_{DD} = PV_{DD}$ ,  $CT = 270pF$ ,  $T_A = -40^\circ C$  to  $85^\circ C$ ,  $T_A = T_J$

Parameter	Test Conditions	Min	Typ	Max	Unit
<b>Overall</b>					
Supply Voltage				5.5	V
Supply Current, Sleep	EN = 0V		0.1	1	$\mu A$
Supply Current, Operating	$AV_{DD} = 5.5V$		2	3.75	mA
$AV_{DD}$ Turn-on Threshold	$T_A = -40^\circ C$ to $85^\circ C$			2.7	V
$AV_{DD}$ Turn-off Hysteresis		275	350	425	mV
<b>Error Amplifier</b>					
FB Voltage (Internal Reference)	$AV_{DD} = 2.7V$ to $5.5V$ , $T_A = -40^\circ C$ to $85^\circ C$	0.49	0.5	0.51	V
	$AV_{DD} = 2.7V$ to $5.5V$ , $T_A = 25^\circ C$	0.493	0.5	0.507	
	$T_A = -40^\circ C$ to $85^\circ C$	0.492	0.5	0.508	
	$T_A = 25^\circ C$	0.495	0.5	0.505	
VSENSE Bias Current	$V_{SENSE} = 0.5V$		200		nA
Open Loop Gain <sup>(1)</sup>	$V_{COMP} = 0.5$ to $2.5V$		90		dB
Unity Gain Bandwidth <sup>(1)</sup>			8		MHz

**POWER MANAGEMENT**
**Electrical Characteristics (Cont.)**

 Unless otherwise specified,  $AV_{DD} = 3.3V$ ,  $AV_{DD} = PV_{DD}$ ,  $CT = 270pF$ ,  $T_A = -40^{\circ}C$  to  $85^{\circ}C$ ,  $T_A = T_J$ 

Parameter	Test Conditions	Min	Typ	Max	Unit
<b>Error Amplifier (Cont.)</b>					
Slew Rate <sup>(1)</sup>			2.4		V/ $\mu$ s
VOUT High	$I_{COMP} = -5.5mA$	$AV_{DD} - 0.5$	$AV_{DD} - 0.3$		V
VOUT Low	$I_{COMP} = 5.5mA$		0.3	0.45	
<b>Oscillator</b>					
Initial Accuracy	$T_A = 25^{\circ}C$	525	575	625	kHz
OSC Line Regulation	$T_A = 25^{\circ}C$ , $AV_{DD} = 2.7V$ to $5.5V$		1	2.5	%/V
Temperature Coefficient	$T_A = -40^{\circ}C$ to $85^{\circ}C$		0.02		%/ $^{\circ}C$
Minimum Operation Frequency <sup>(1)</sup>		50			kHz
Maximum Operation Frequency <sup>(1)</sup>				1M	Hz
Ramp Peak to Valley			1		V
Ramp Peak Voltage			1.3		V
Ramp Valley Voltage			0.3		V
<b>Soft Start, Current Limit</b>					
Programmable Soft Start Time <sup>(1)</sup>	$C = 22nF$		2		ms
Soft Start Charge Current	$T_A = 25^{\circ}C$	-4	-5.25	-6.5	$\mu$ A
ISET Bias Current	$T_J = 25^{\circ}C$	-45	-50	-55	$\mu$ A
Temperature Coefficient of ISET			0.3		%/ $^{\circ}C$
Current Limit Blank Time <sup>(1)</sup>			130		ns
<b>Gate Drive</b>					
DRVH Minimum OFF Time <sup>(1)</sup>	$T_A = 25^{\circ}C$		160		ns
Peak Source (DRVH)	$V_{gs} = 3.3V$ , $I_{SOURCE} = 100mA$		3.5	6	$\Omega$
Peak Sink (DRVH)	$V_{gs} = 3.3V$ , $I_{SINK} = 100mA$		3	5	$\Omega$
Peak Source (DRVL) <sup>(1)</sup>	$V_{gs} = 3.3V$ , $I_{SOURCE} = 100mA$		2.2		$\Omega$
Peak Sink (DRVL)	$V_{gs} = 3.3V$ , $I_{SINK} = 100mA$		2	4	$\Omega$
Output Rise Time	$V_{gs} = 3.3V$ , $C_{OUT} = 4.7nF$		35		ns
Output Fall Time	$V_{gs} = 3.3V$ , $C_{OUT} = 4.7nF$		27		ns
Minimum Non-Overlap <sup>(1)</sup>			40		ns

**POWER MANAGEMENT**
**Electrical Characteristics**

Unless otherwise specified,  $AV_{DD} = 3.3V$ ,  $AV_{DD} = PV_{DD}$ ,  $CT = 270pF$ ,  $T_A = -40^{\circ}C$  to  $85^{\circ}C$ ,  $T_A = T_J$

Parameter	Test Conditions	Min	Typ	Max	Unit
<b>Power Good</b>					
PGOOD Voltage Low	$I_{PGOOD} = 1mA$ , $AV_{DD} = 5.5V$		0.15	0.3	V
PGOOD Leakage Current	$AV_{DD} = 5.5V$			1	$\mu A$
PGOOD Upper Threshold		7.5	11.5	15.5	%
PGOOD Lower Threshold		-14.5	-10.5	-6.5	%
PGOOD Delay			14		ms
<b>Enable</b>					
High Level Threshold		$0.7 * AV_{DD}$			V
Low Level Threshold				$0.3 * AV_{DD}$	V
EN Input Bias Current	$V_{EN} = 0V$		-10		nA

Note: (1). Guaranteed by design.

**POWER MANAGEMENT**

**Pin Configuration**

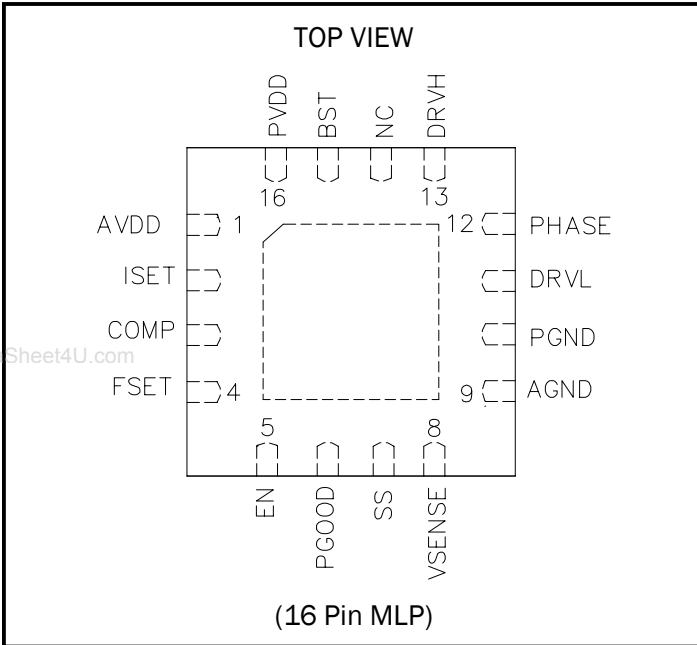

**Ordering Information**

Part Number	Device <sup>(1)</sup>
SC4608MLTRT <sup>(2)</sup>	MLP-16
SC4608EVB	Evaluation Board

**Notes:**

- (1) Only available in tape and reel packaging. A reel contains 3000 devices.
- (2) Lead free product. This product is fully WEEE and RoHS compliant.

**Pin Descriptions**

Pin #	Pin Name	Pin Function
1	AVDD	Power supply voltage for the analog section of the controller.
2	ISET	The ISET pin is used to limit current in the high side MOSFET. The SC4608 uses the voltage across the $V_{IN}$ and ISET pins in order to set the current limit. The current limit threshold is set by the value of an external resistor (R3 in the Typical Application Circuit Diagram). Current limiting is performed by comparing the voltage drop across the sense resistor with the voltage drop across the drain to source resistance of the high side MOSFET during the MOSFET's conduction period. The voltage drop across the drain to source resistance of the high side MOSFET is obtained from the $V_{IN}$ and PHASE pin.
3	COMP	This is the output of the voltage error amplifier. The voltage at this output is inverted internally and connected to the non-inverting input of the PWM comparator. A lead-lag network from the COMP pin to the VSENSE pin compensates for the two pole LC filter characteristics inherent to voltage mode control. The lead-lag network is required in order to optimize the dynamic performance of the voltage mode control loop.
4	FSET	The FSET pin is used to sets the PWM oscillator frequency through an external timing capacitor that is connected from the FSET pin to the GND pin. The SC4608 can be operated in synchronous mode by placing a resistor in series between the timing capacitor and ground. The other terminal of the timing capacitor will remain connected to the FSET pin.
5	EN	The oscillator frequency of the SC4608 is set by FSET when EN is pulled and held above $0.7 * AV_{DD}$ . Its shutdown mode is invoked if EN is pulled and held below $0.3 * AV_{DD}$ .

**POWER MANAGEMENT**
**Pin Descriptions (Cont.)**

Pin #	Pin Name	Pin Function
6	PGOOD	Power good open drain output. Low when the output is below the power good threshold level.
7	SS	Soft start. A capacitor to ground sets the soft start time. The soft start time is independent of switching frequency and is defined as $SS = 0.09 \cdot C$ . Where C is the external capacitor in nF and SS is the soft start time in ms.
8	VSENSE	This pin is the inverting input of the voltage amplifier and serves as the output voltage feedback point for the Buck converter. VSENSE is compared to an internal reference value of 0.5V. VSENSE is hardwired to the output voltage when an output of 0.5V is desired. For higher output voltages, a resistor divider network is necessary (R7 and R9 in the Typical Application Circuit Diagram).
9	AGND	Analog ground.
10	PGND	Power ground.
11	DRVL	DRVL drives the gate of the low side (synchronous rectifier) MOSFET. The output drivers are rated for 1A peak currents. The PWM circuitry provides complementary drive signals to the output stages. The cross conduction of the external MOSFETs is prevented by monitoring the voltage on the driver pins of the MOSFET pair in conjunction with a time delay optimized for FET turn-off characteristics.
12	PHASE	The PHASE pin is used to limit current in the high side MOSFET. The SC4608 uses the voltage across the $V_{IN}$ and ISET pin in order to set the current limit. The current limit threshold is set by the value of an external resistor (R3 in the Typical Application Circuit Diagram). Current limiting is performed by comparing the voltage drop across the sense resistor with the voltage drop across the drain to source resistance of the high side MOSFET during the MOSFET's conduction period. The voltage drop across the drain to source resistance of the high side MOSFET is obtained from the $V_{IN}$ and PHASE pin.
13	DRVH	DRVH drives the gate of the high side (main switch) MOSFET. The output drivers are rated for 1A peak currents. The PWM circuitry provides complementary drive signals to the output stages. The cross conduction of the external MOSFETs is prevented by monitoring the voltage on the driver pins of the MOSFET pair in conjunction with a time delay optimized for FET turn-off characteristics.
14	NC	No connection.
15	BST	This pin enables the converter to drive an N-Channel high side MOSFET. BST connects to the external charge pump circuit. The charge pump circuit boosts the BST pin voltage to a sufficient gate-to-source voltage level for driving the gate of the high side MOSFET.
16	PVDD	Power supply voltage for low side MOSFET.
	Thermal Pad	Pad for heatsinking purposes. Connect to ground plane using multiple vias. Not connected internally.

POWER MANAGEMENT

Block Diagram

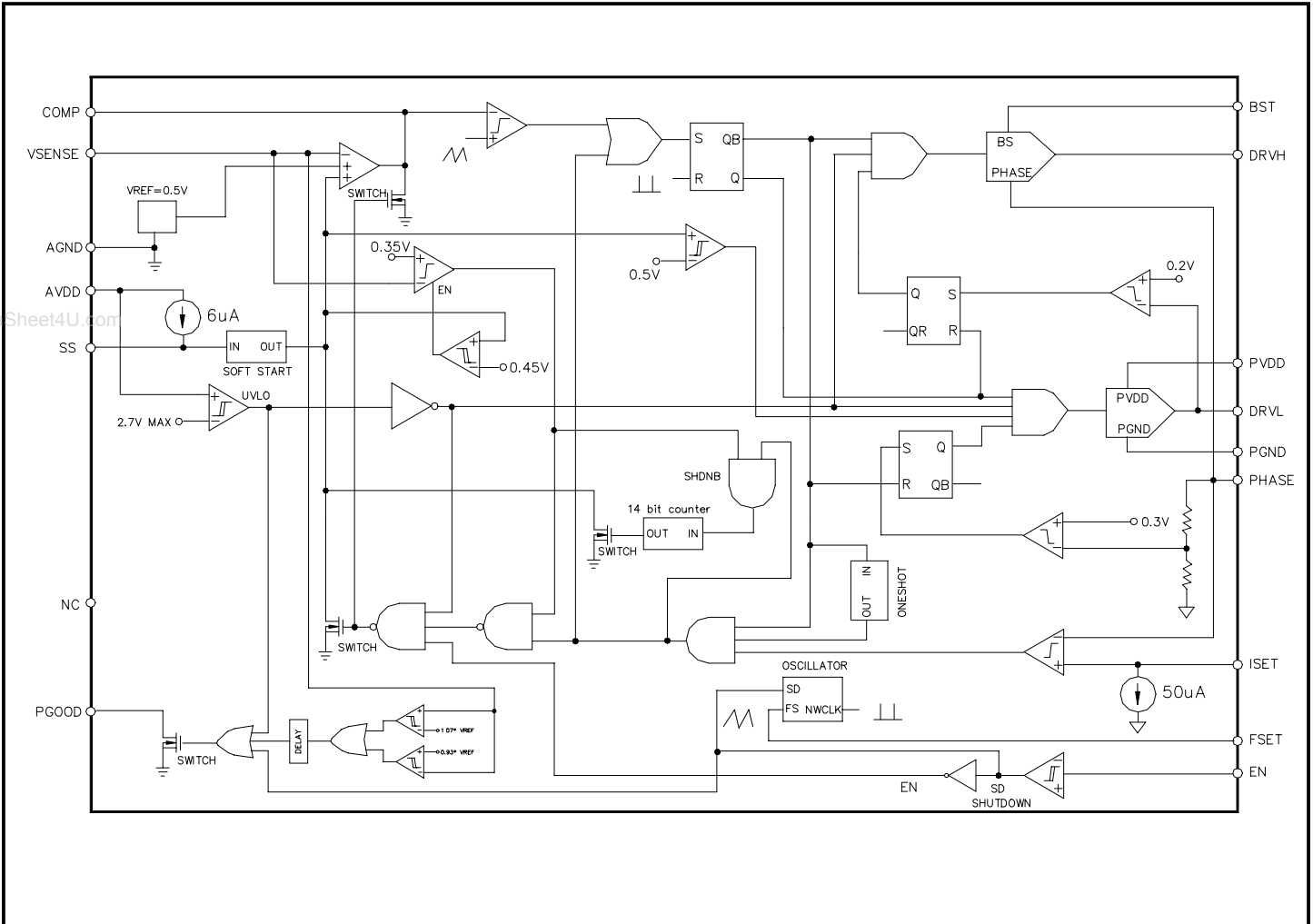

**POWER MANAGEMENT**
**Application Information**
**Enable**

The SC4608 is enabled by applying a voltage greater than 2.7 volts to the  $AV_{DD}$  pin. The SC4608 is disabled when  $AV_{DD}$  falls below 2.35 volts or when sleep mode operation is invoked by clamping the EN pin to a voltage below  $0.3 \cdot AV_{DD}$ .  $0.1\mu A$  is the typical current drawn through the  $AV_{DD}$  pin during sleep mode. During the sleep mode, the high side and low side MOSFETs are turned off and the internal soft start voltage is held low.

**Oscillator**

The FSET pin is used to set the PWM oscillator frequency through an external timing capacitor that is connected from the FSET pin to the GND pin. The resulting ramp waveform on the FSET pin is a triangle at the PWM frequency with a peak voltage of 1.3V and a valley voltage of 0.3V. 160ns minimum OFF time for the top switch allows the bootstrap capacitor to be charged during each cycle. The capacitor tolerance adds to the accuracy of the oscillator frequency. The approximate operating frequency and soft start time are both determined by the value of the external timing capacitor as shown in Table 1.

External Timing Capacitor Value (pF)	Frequency (kHz)
120	1000
270	575
470	350
560	295

**Table 1.** Operating Frequency value Based on the Value of the External Timing Capacitor Placed Across the FSET and GND Pins

Synchronous mode operation is invoked by using a signal from an external clock. A low value resistor (100Ω typical) must be inserted in series with the timing capacitor between the timing capacitor and the GND pin. The other terminal of the timing capacitor will remain connected to the FSET pin. The transformed external clock signal is then connected to the junction of the external timing capacitor and the added resistor  $R_{SYNC}$  as shown in Figure 1.

The maximum frequency of the external clock signal can be higher than the natural switching frequency by about 10%.

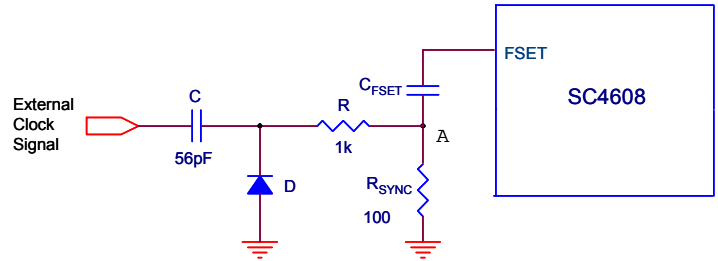

**Figure 1**

**UVLO**

When the EN pin is not pulled and held below  $0.3 \cdot AV_{DD}$ , the voltage on the  $AV_{DD}$  pin determines the operation of the SC4608. As  $AV_{DD}$  increases during start up, the UVLO block senses  $AV_{DD}$  and keeps the high side and low side MOSFETs off and the internal soft start voltage low until  $AV_{DD}$  reaches 2.7V. If no faults are present, the SC4608 will initiate a soft start when  $AV_{DD}$  exceeds 2.7V. A hysteresis (350mV) in the UVLO comparator provides noise immunity during its start up.

**Power Good Indicator**

The PGOOD pin is the open-drain output of the power good comparators. These comparators are incorporated with small amount of hysteresis. A pull-up resistor from the PGOOD pin to the input supply or the output sets the logic high level of the PGOOD signal. The VSENSE low-to-high trip voltage of the power good comparator is 89% of the final regulation voltage. The power good comparator output becomes valid provided that  $V_o$  is within about  $\pm 11\%$  of the programmed output voltage. In shutdown mode the power good output is actively pulled low. The PGOOD signal delay depends on its operating frequency  $f_s$ , for example, about 14ms@  $f_s=575kHz$  and 24ms @  $f_s=330kHz$ .

**Soft Start**

The soft start function is required for step down controllers to prevent excess inrush current through the DC bus during start up. Generally this can be done by sourcing a controlled current into a timing capacitor and then using the voltage across this capacitor to slowly ramp up the error amp reference. The closed loop creates narrow



**POWER MANAGEMENT**

**Application Information (Cont.)**

width driver pulses while the output voltage is low and allows these pulses to increase to their steady state duty cycle as the output voltage reaches its regulated value. With this, the inrush current from the input side is controlled. The duration of the soft start in the SC4608 is controlled by an external capacitor. SS, the start-up time is defined as:

$$SS = 0.09 \cdot C$$

where, C is the value of the external capacitor in nF, and SS is the start-up time in ms.

**Over Current Protection**

The SC4608 detects over current conditions by sensing the voltage across the drain-to-source of the high side MOSFET. The SC4608 determines the high side MOSFET current level by sensing the drain-to-source conduction voltage across the high side MOSFET via the  $V_{in}$  (see the Typical Application Circuit on page 1) and PHASE pin during the high side MOSFETs conduction period. This voltage value is then compared internally to a user programmed current limit threshold. Note that user should place Kelvin sensing connections directly from the high side MOSFET source to the PHASE pin.

The current limit threshold is programmed by the user based on the  $R_{DS(on)}$  of the high side MOSFET and the value of the external set resistor RSET (where RSET is represented by R3 in the applications schematics of this document). The SC4608 uses an internal current source to pull a  $50\mu A$  current from the input voltage to the ISET pin through external resistor RSET.

The current limit threshold resistor (RSET) value is calculated using the following equation:

$$R_{SET} = \frac{I_{MAX} \cdot R_{DS(ON)}}{50\mu A}$$

The  $R_{DS(ON)}$  sensing used in the SC4608 has an additional feature that enhances the performance of the over current protection. Because the  $R_{DS(ON)}$  has a positive temperature coefficient, the  $50\mu A$  current source has a positive coefficient of about  $0.3\%/C^\circ$  providing first order correction for current sensing vs temperature. This compensation depends on the high amount of thermal transferring that typically exists between the high side N-MOSFET and the SC4608 due to the compact layout of the power supply.

When the converter detects an over current condition ( $I > I_{MAX}$ ) as shown in Figure 2, the first action the SC4608 takes is to enter the cycle by cycle protection mode (Point B to Point C), which responds to minor over current cases. Then the output voltage is monitored. If the over current and low output voltage (set at 70% of nominal output voltage) occur at the same time, the Hiccup mode operation (Point C to Point D) of the SC4608 is invoked and the internal soft start capacitor is discharged. This is like a typical soft start cycle:

Figure 2. Over current protection characteristic of SC4608

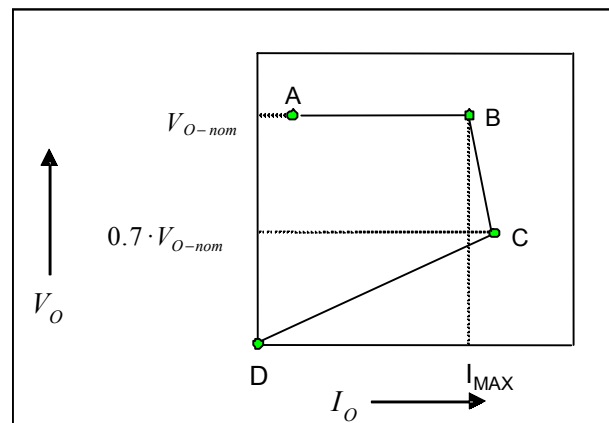

**Power MOSFET Drivers**

The SC4608 has two drivers which are optimized for driving external power N-Channel MOSFETs. The driver block consists two 1 Amp drivers. DRVH drives the high side N-MOSFET (main switch), and DRVL drives the low side N-MOSFET (synchronous rectifier transistor).

The output drivers also have gate drive non-overlap mechanism that provides a dead time between DRVH and DRVL transitions to avoid potential shoot through problems in the external MOSFETs. By using the proper design and the appropriate MOSFETs, the SC4608 is capable of driving a converter with up to 12A of output current. As shown in Figure 3,  $t_{d1}$  the delay from the top MOSFET off to the bottom MOSFET on is adaptive by detecting the voltage of the phase node.  $t_{d2}$ , the delay from the bottom MOSFET off to the top MOSFET on is fixed, is 40ns for the SC4608. This control scheme guarantees avoidance of cross conduction or shoot through

**POWER MANAGEMENT**
**Application Information (Cont.)**

between the upper and lower MOSFETs and also minimizes the conduction loss in the body diode of the bottom MOSFET for high efficiency applications.

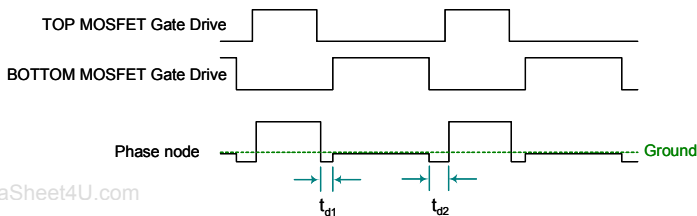

Figure 3. Timing Waveforms for Gate Drives and Phase Node

**Inductor Selection**

The factors for selecting the inductor include its cost, efficiency, size and EMI. For a typical SC4608 application, the inductor selection is mainly based on its value, saturation current and DC resistance. Increasing the inductor value will decrease the ripple level of the output voltage while the output transient response will be degraded. Low value inductors offer small size and fast transient responses while they cause large ripple currents, poor efficiencies and more output capacitance to smooth out the large ripple currents. The inductor should be able to handle the peak current without saturating and its copper resistance in the winding should be as low as possible to minimize its resistive power loss. A good trade-off among its size, loss and cost is to set the inductor ripple current to be within 15% to 30% of the maximum output current.

The inductor value can be determined according to its operating point and the switching frequency as follows:

$$L = \frac{V_{OUT} \cdot (V_{IN} - V_{OUT})}{V_{IN} \cdot f_s \cdot \Delta I \cdot I_{OMAX}}$$

Where:

$f_s$  = switching frequency and

$\Delta I$  = ratio of the peak to peak inductor current to the maximum output load current.

The peak to peak inductor current is:

$$I_{p-p} = \Delta I \cdot I_{OMAX}$$

After the required inductor value is selected, the proper selection of the core material is based on the peak inductor current and efficiency requirements. The core

must be able to handle the peak inductor current  $I_{PEAK}$  without saturation and produce low core loss during the high frequency operation is:

$$I_{PEAK} = I_{OMAX} + \frac{I_{p-p}}{2}$$

The power loss for the inductor includes its core loss and copper loss. If possible, the winding resistance should be minimized to reduce inductor's copper loss. The core loss can be found in the manufacturer's datasheet. The inductor' copper loss can be estimated as follows:

$$P_{COPPER} = I_{LRMS}^2 \cdot R_{WINDING}$$

Where:

$I_{LRMS}$  is the RMS current in the inductor. This current can be calculated as follow is:

$$I_{LRMS} = I_{OMAX} \cdot \sqrt{1 + \frac{1}{3} \cdot \Delta I^2}$$

**Output Capacitor Selection**

Basically there are two major factors to consider in selecting the type and quantity of the output capacitors. The first one is the required ESR (Equivalent Series Resistance) which should be low enough to reduce the voltage deviation from its nominal one during its load changes. The second one is the required capacitance, which should be high enough to hold up the output voltage. Before the SC4608 regulates the inductor current to a new value during a load transient, the output capacitor delivers all the additional current needed by the load. The ESR and ESL of the output capacitor, the loop parasitic inductance between the output capacitor and the load combined with inductor ripple current are all major contributors to the output voltage ripple. Surface mount speciality polymer aluminum electrolytic chip capacitors in UE series from Panasonic provide low ESR and reduce the total capacitance required for a fast transient response. POSCAP from Sanyo is a solid electrolytic chip capacitor that has a low ESR and good performance for high frequency with a low profile and high capacitance. Above mentioned capacitors are recommended to use in SC4608 application.

**Input Capacitor Selection**

The input capacitor selection is based on its ripple current level, required capacitance and voltage rating. This capacitor must be able to provide the ripple current by the switching actions. For the continuous conduction

**POWER MANAGEMENT**
**Application Information (Cont.)**

mode, the RMS value of the input capacitor can be calculated from:

$$I_{CIN(RMS)} = I_{OMAX} \cdot \sqrt{\frac{V_{OUT} \cdot (V_{IN} - V_{OUT})}{V_{IN}^2}}$$

This current gives the capacitor's power loss as follows:

$$P_{CIN} = I_{CIN(RMS)}^2 \cdot R_{CIN(ESR)}$$

This capacitor's RMS loss can be a significant part of the total loss in the converter and reduce the overall converter efficiency. The input ripple voltage mainly depends on the input capacitor's ESR and its capacitance for a given load, input voltage and output voltage. Assuming that the input current of the converter is constant, the required input capacitance for a given voltage ripple can be calculated by:

$$C_{IN} = I_{OMAX} \cdot \frac{D \cdot (1-D)}{f_s \cdot (\Delta V_I - I_{OMAX} \cdot R_{CIN(ESR)})}$$

Where:

$D = V_O / V_I$ , duty ratio and

$\Delta V_I$  = the given input voltage ripple.

Because the input capacitor is exposed to the large surge current, attention is needed for the input capacitor. If tantalum capacitors are used at the input side of the converter, one needs to ensure that the RMS and surge ratings are not exceeded. For generic tantalum capacitors, it is wise to derate their voltage ratings at a ratio of 2 to protect these input capacitors.

**Boost Capacitor Selection**

The boost capacitor selection is based on its discharge ripple voltage, worst case conduction time and boost current. The worst case conduction time  $T_w$  can be estimated as follows:

$$T_w = \frac{1}{f_s} \cdot D_{max}$$

Where:

$f_s$  = the switching frequency and

$D_{max}$  = maximum duty ratio.

The required minimum capacitance for boost capacitor will be:

$$C_{boost} = \frac{I_B}{V_D} \cdot T_w$$

Where:

$I_B$  = the boost current and

$V_D$  = discharge ripple voltage.

With  $f_s = 300kHz$ ,  $V_D = 0.3V$  and  $I_B = 50mA$ , the required capacitance for the boost capacitor is:

$$C_{boost} = \frac{I_B}{V_D} \cdot \frac{1}{f_s} \cdot D_{max} = \frac{0.05}{0.3} \cdot \frac{1}{300k} \cdot 0.95 = 528nF$$

**Power MOSFET Selection**

The SC4608 can drive an N-MOSFET at the high side and an N-MOSFET synchronous rectifier at the low side. The use of the high side N-MOSFET will significantly reduce its conduction loss for high current. For the top MOSFET, its total power loss includes its conduction loss, switching loss, gate charge loss, output capacitance loss and the loss related to the reverse recovery of the bottom diode, shown as follows:

$$P_{TOP\_TOTAL} = I_{TOP\_RMS}^2 \cdot R_{TOP\_ON} + \frac{I_{TOP\_PEAK} \cdot V_I \cdot f_s}{V_{GATE} / R_G} \cdot (Q_{GD} + Q_{GS2}) + Q_{GT} \cdot V_{GATE} \cdot f_s + (Q_{OSS} + Q_{rr}) \cdot V_I \cdot f_s$$

Where:

$R_G$  = gate drive resistor,

$Q_{GD}$  = the gate to drain charge of the top MOSFET,

$Q_{GS2}$  = the gate to source charge of the top MOSFET,

$Q_{GT}$  = the total gate charge of the top MOSFET,

$Q_{OSS}$  = the output charge of the top MOSFET and

$Q_{rr}$  = the reverse recovery charge of the bottom diode.

For the top MOSFET, it experiences high current and high voltage overlap during each on/off transition. But for the bottom MOSFET, its switching voltage is the bottom diode's forward drop during its on/off transition. So the switching loss for the bottom MOSFET is negligible. Its total power loss can be determined by:

$$P_{BOT\_TOTAL} = I_{BOT\_RMS}^2 \cdot R_{BOT\_ON} + Q_{GB} \cdot V_{GATE} \cdot f_s + I_{D\_AVG} \cdot V_F$$

Where:

$Q_{GB}$  = the total gate charge of the bottom MOSFET and

$V_F$  = the forward voltage drop of the bottom diode.

**POWER MANAGEMENT**

**Application Information (Cont.)**

For a low voltage and high output current application such as the 3.3V/1.5V@12A case, the conduction loss is often dominant and selecting low  $R_{DS(ON)}$  MOSFETs will noticeably improve the efficiency of the converter even though they give higher switching losses.

The gate charge loss portion of the top/bottom MOSFET's total power loss is derived from the SC4608. This gate charge loss is based on certain operating conditions ( $f_s$ ,  $V_{GATE}$  and  $I_o$ ).

The thermal estimations have to be done for both MOSFETs to make sure that their junction temperatures do not exceed their thermal ratings according to their total power losses  $P_{TOTAL}$ , ambient temperature  $T_A$  and their thermal resistance  $R_{\theta JA}$  as follows:

$$T_{J(max)} < T_A + \frac{P_{TOTAL}}{R_{\theta JA}}$$

**Loop Compensation Design**

For a DC/DC converter, it is usually required that the converter has a loop gain of a high cross-over frequency for fast load response, high DC and low frequency gain for low steady state error, and enough phase margin for its operating stability. Often one can not have all these properties at the same time. The purpose of the loop compensation is to arrange the poles and zeros of the compensation network to meet the requirements for a specific application.

The SC4608 has an internal error amplifier and requires the compensation network to connect among the COMP pin and VSENSE pin, GND, and the output as shown in Figure 4. The compensation network includes C1, C2, R1, R7, R8 and C9. R9 is used to program the output voltage according to:

$$V_o = 0.5 \cdot \left(1 + \frac{R_7}{R_9}\right)$$

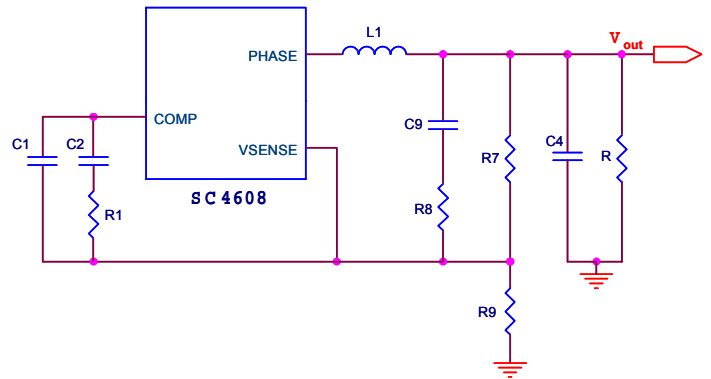

Figure 4. Compensation network provides 3 poles and 2 zeros.

For voltage mode step down applications as shown in Figure 4, the power stage transfer function is:

$$G_{VD}(s) = V_i \frac{1 + \frac{s}{1}}{\frac{R_c \cdot C_4}{1 + s \frac{L_1}{R} + s^2 L_1 C_4}}$$

Where:  
R = load resistance and  
 $R_c = C_4$ 's ESR.

The compensation network will have the characteristic as follows:

$$G_{COMP}(s) = \frac{\omega_1}{s} \cdot \frac{1 + \frac{s}{\omega_{Z1}}}{1 + \frac{s}{\omega_{P1}}} \cdot \frac{1 + \frac{s}{\omega_{Z2}}}{1 + \frac{s}{\omega_{P2}}}$$

Where

$$\omega_1 = \frac{1}{R_7 \cdot (C_1 + C_2)}$$

$$\omega_{Z1} = \frac{1}{R_1 \cdot C_2}$$

$$\omega_{Z2} = \frac{1}{(R_7 + R_8) \cdot C_9}$$

$$\omega_{P1} = \frac{C_1 + C_2}{R_1 \cdot C_1 \cdot C_2}$$

**POWER MANAGEMENT**

**Application Information (Cont.)**

$$\omega_{P2} = \frac{1}{R_8 \cdot C_9}$$

After the compensation, the converter will have the following loop gain:

$$T(s) = G_{PWM} \cdot G_{COMP}(s) \cdot G_{VD}(s) = \frac{1}{V_M} \cdot \omega_1 \cdot V_I \cdot \frac{1 + \frac{s}{\omega_{Z1}}}{s} \cdot \frac{1 + \frac{s}{\omega_{Z2}}}{1 + \frac{s}{\omega_{P1}}} \cdot \frac{1 + \frac{s}{\omega_{P2}}}{1 + s \frac{L_1}{R} + s^2 L_1 C}$$

Where:

$G_{PWM}$  = PWM gain

$V_M$  = 1.0V, ramp peak to valley voltage of SC4608

The design guidelines for the SC4608 applications are as following:

1. Set the loop gain crossover corner frequency  $\omega_c$  for given switching corner frequency  $\omega_s = 2\pi f_s$ ,
2. Place an integrator at the origin to increase DC and low frequency gains.
3. Select  $\omega_{Z1}$  and  $\omega_{Z2}$  such that they are placed near  $\omega_0$  to damp the peaking and the loop gain has a -20dB/dec rate to go across the 0dB line for obtaining a wide bandwidth.
4. Cancel the zero from  $C_4$ 's ESR by a compensator pole  $\omega_{P1}$  ( $\omega_{P1} = \omega_{ESR} = 1/(R_C C_4)$ ).
5. Place a high frequency compensator pole  $\omega_{P2}$  ( $\omega_{P2} = \pi f_s$ ) to get the maximum attenuation of the switching ripple and high frequency noise with the adequate phase lag at  $\omega_c$ .

The compensated loop gain will be as given in Figure 5:

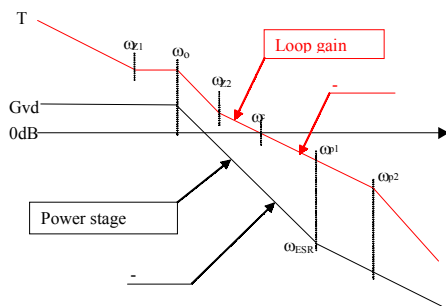

Figure 5. Asymptotic diagrams of power stage and its loop gain

**Layout Guidelines**

In order to achieve optimal electrical, thermal and noise performance for high frequency converters, special attention must be paid to the PCB layouts. The goal of layout optimization is to identify the high di/dt loops and minimize them. The following guideline should be used to ensure proper functions of the converters.

1. A ground plane is recommended to minimize noises and copper losses, and maximize heat dissipation.
2. Start the PCB layout by placing the power components first. Arrange the power circuit to achieve a clean power flow route. Put all the connections on one side of the PCB with wide copper filled areas if possible.
3. The  $AV_{DD}$  bypass capacitor should be placed next to the  $AV_{DD}$  and AGND pins.
4. The trace connecting the feedback resistors to the output should be short, direct and far away from the noise sources such as switching node and switching components.
5. Minimize the traces between DRVH/DRVL and the gates of the MOSFETs to reduce their impedance to drive the MOSFETs.
6. Minimize the loop including input capacitors, top/bottom MOSFETs. This loop passes high di/dt current. Make sure the trace width is wide enough to reduce copper losses in this loop.
7. ISET and PHASE connections to the top MOSFET for current sensing must use Kelvin connections.
8. Maximize the trace width of the loop connecting the inductor, bottom MOSFET and the output capacitors.
9. Connect the ground of the feedback divider and the compensation components directly to the AGND pin of the SC4608 by using a separate ground trace. Then connect this pin to the ground of the output capacitor as close as possible

**POWER MANAGEMENT**

**Application Information (Cont.)**

**Design Example 1.** 3V to 1.5V @10A application with SC4608

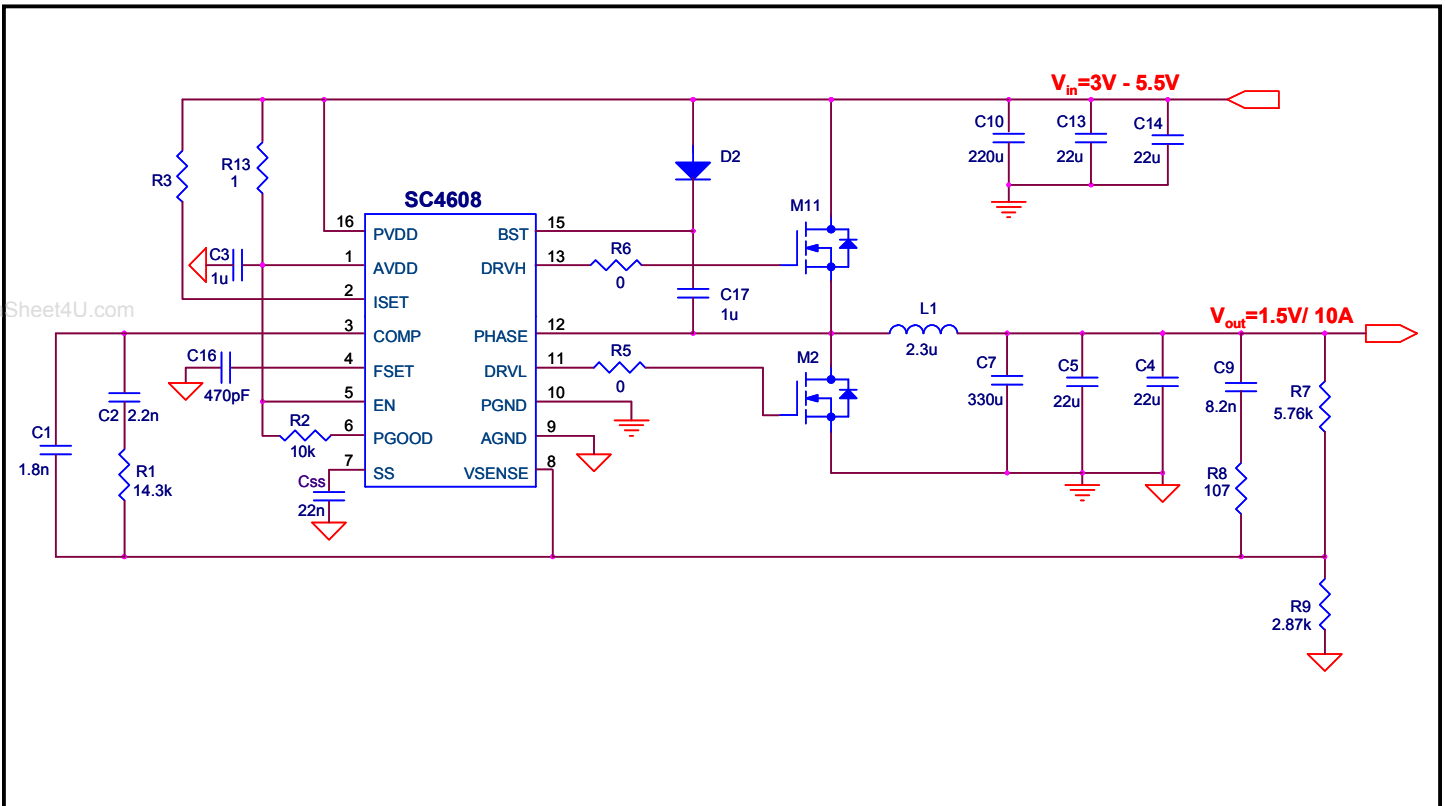

**POWER MANAGEMENT**
**Bill of Materials**

Item	Qty	Reference	Value	Part No./Manufacturer
1	1	C1	1.8nF	
2	1	C2	2.2nF	
3	1	C17	1uF	
4	4	C4,C5, C13, C14	22uF, 1206	TDK P/N: C3225X5R0J226M
5	1	C7	330uF, 2870	Sanyo P/N: 6TPB330ML
6	1	C9	8.2nF	
7	1	C16	470pF	
8	1	D2	MBR0520LT1	ON Semi P/N: MBR0520LT1
9	1	L1	2.3uH	Cooper Electronic P/N: HC1-2R3
10	2	M1, M2	Powerpack, SO-8	Vishay P/N: Si7882DP
11	1	R1	14.3K	
12	1	R3	1.33K	
13	1	R7	5.76K	
14	1	R8	107	
15	1	R9	2.87K	
16	1	R13	1	
17	1	C3	1uF, 0805	
18	1	C10	220uF, 2870	Sanyo P/N: 6TPB220ML
19	1	Css	22nF	
20	1	U1	SC4608	Semtech P/N: SC4608IMLTRT
21	1	R2	10k	

Unless specified, all resistors have 1% precision with 0603 package.  
Resistors are +/-1% and all capacitors are +/-20%

COMPONENT SIDE (TOP)

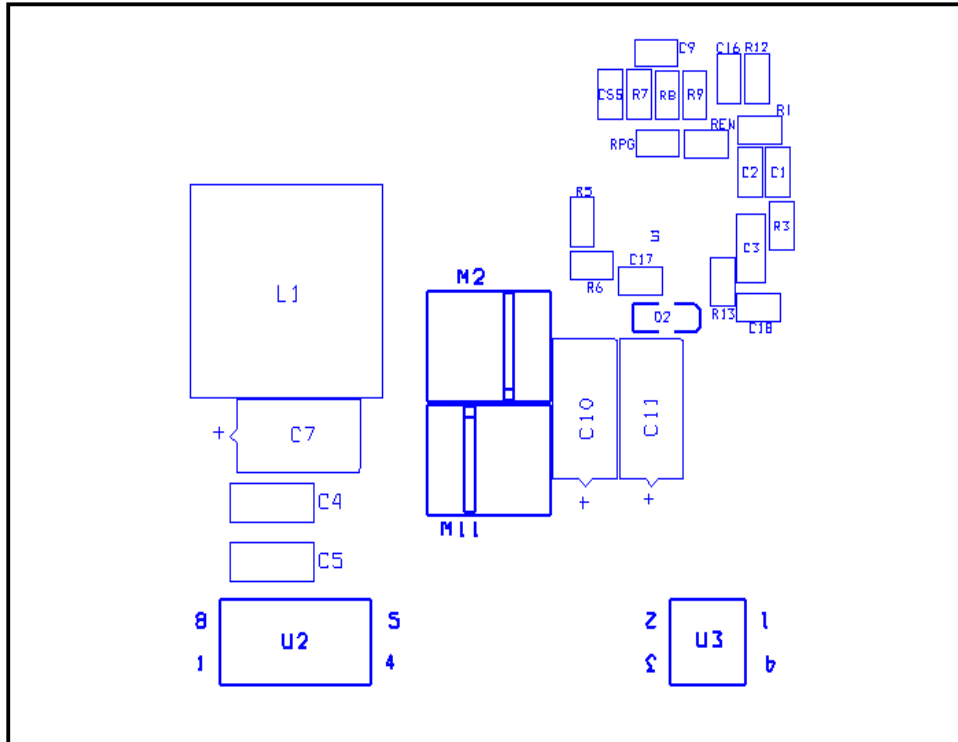

COMPONENT SIDE (BOTTOM)

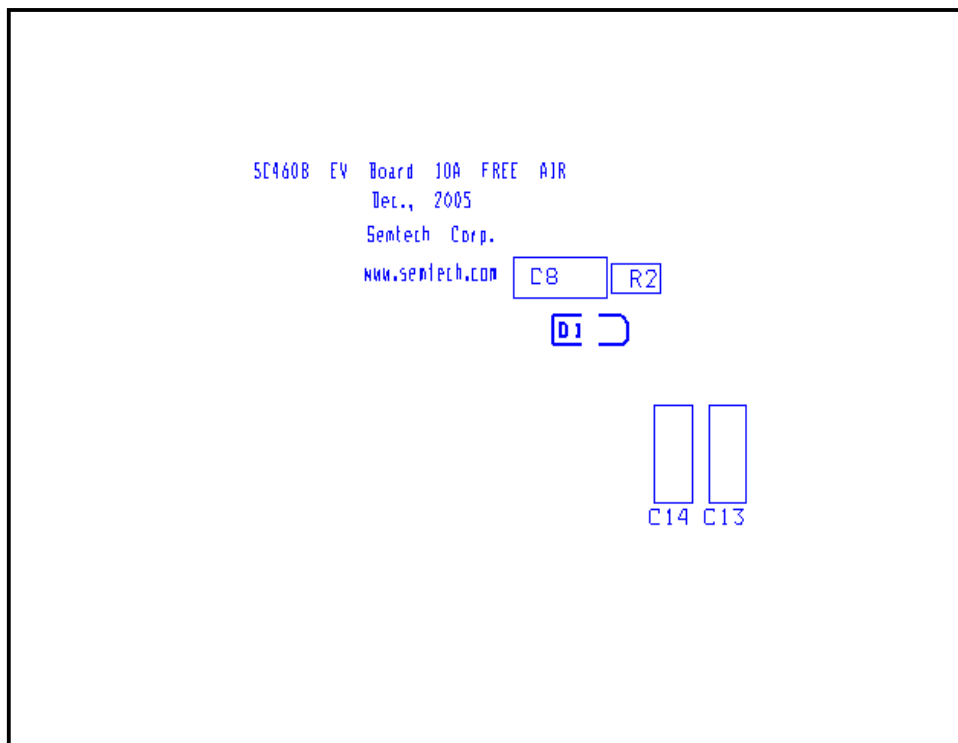



**POWER MANAGEMENT**

**PCB Layout (Cont.)**

(TOP)

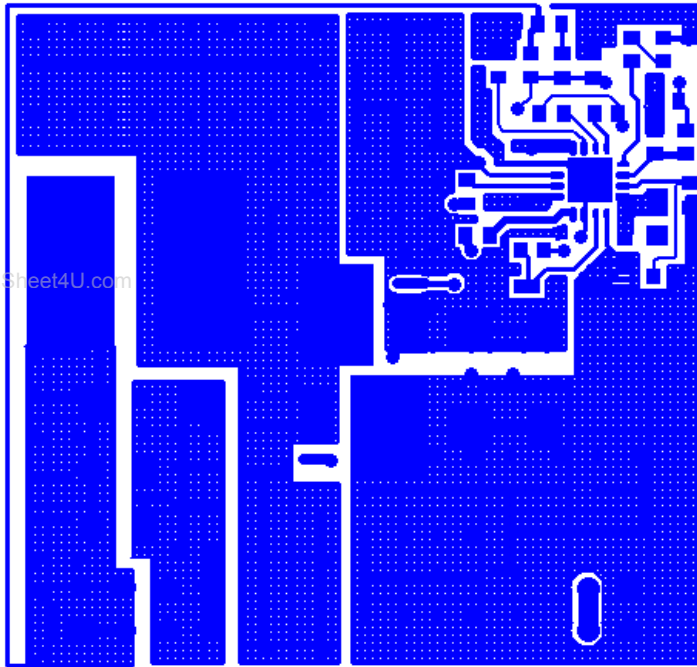

(BOTTOM)

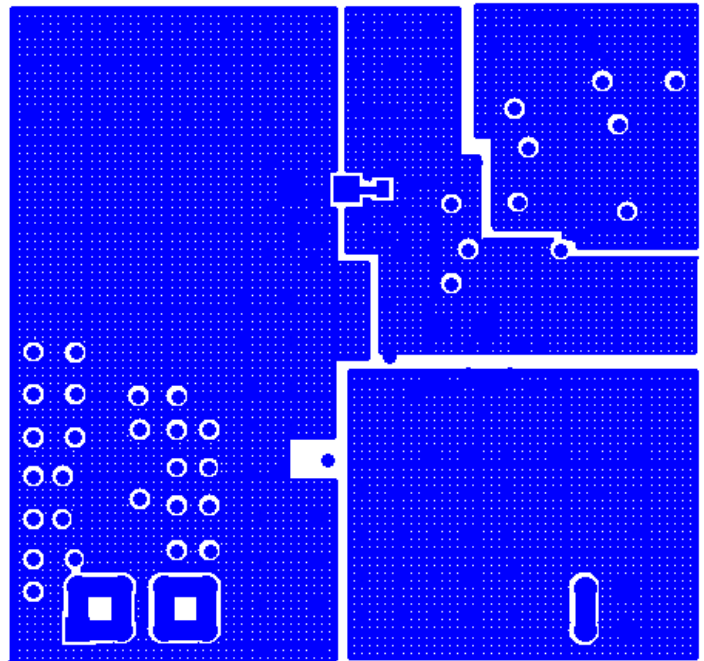

(INTER LAYER 1)

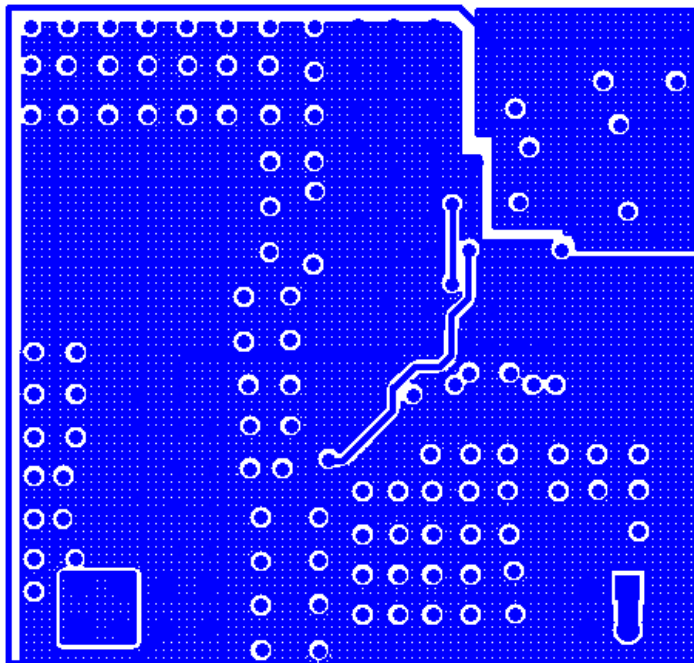

(INTER LAYER 2)

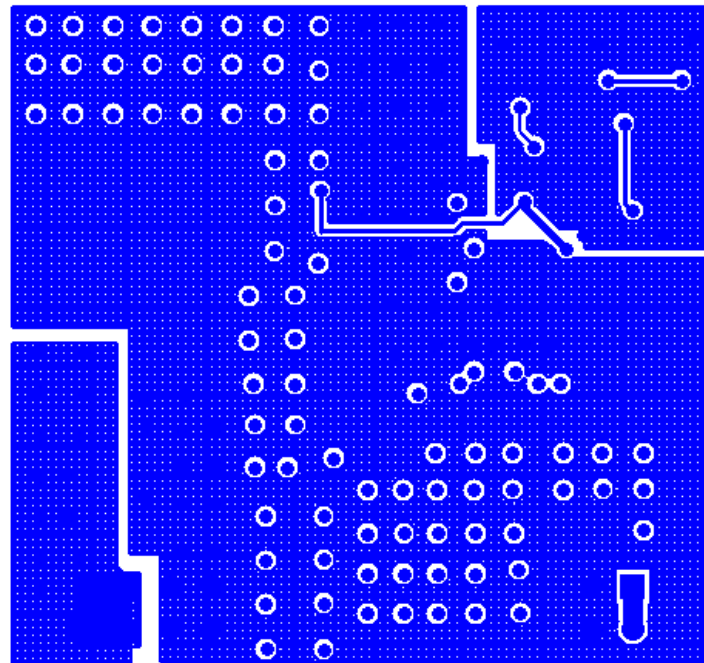

POWER MANAGEMENT

Outline Drawing - MLP-16

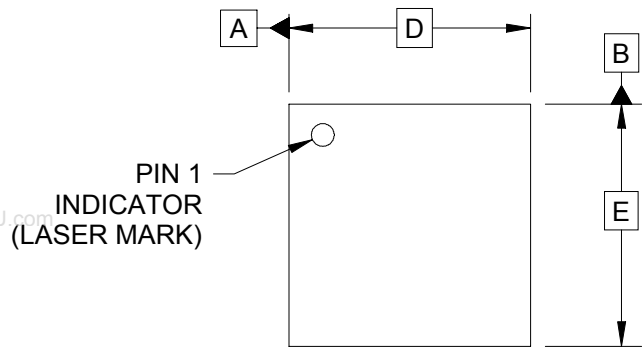

DIMENSIONS						
DIM	INCHES			MILLIMETERS		
	MIN	NOM	MAX	MIN	NOM	MAX
A	.031	-	.040	0.80	-	1.00
A1	.000	-	.002	0.00	-	0.05
A2	-	(.008)	-	-	(0.20)	-
b	.010	.012	.014	0.25	0.30	0.35
D	.153	.157	.161	3.90	4.00	4.10
D1	.100	.106	.110	2.55	2.70	2.80
E	.153	.157	.161	3.90	4.00	4.10
E1	.100	.106	.110	2.55	2.70	2.80
e	.026 BSC			0.65 BSC		
L	.012	.016	.020	0.30	0.40	0.50
N	16			16		
aaa	.003			0.08		
bbb	.004			0.10		

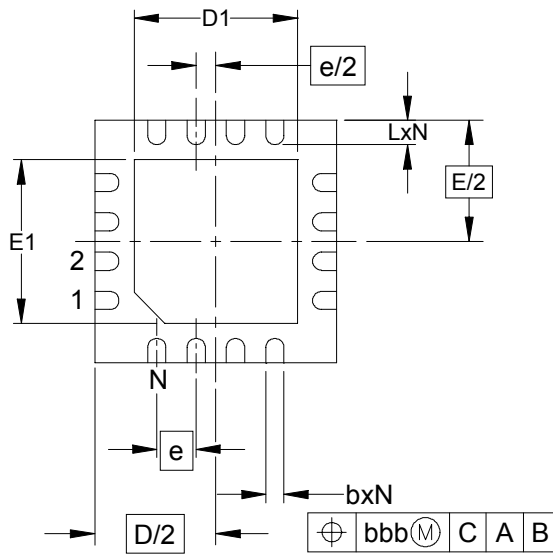
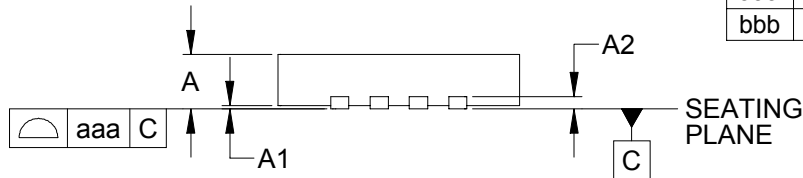

NOTES:

1. CONTROLLING DIMENSIONS ARE IN MILLIMETERS (ANGLES IN DEGREES).
2. COPLANARITY APPLIES TO THE EXPOSED PAD AS WELL AS THE TERMINALS.

**POWER MANAGEMENT**

**Land Pattern - MLP-16**

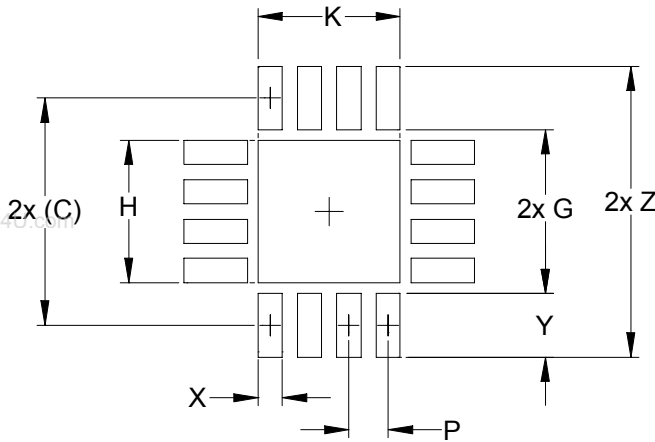

DIMENSIONS		
DIM	INCHES	MILLIMETERS
C	(.156)	(3.95)
G	.122	3.10
H	.106	2.70
K	.106	2.70
P	.026	0.65
X	.016	0.40
Y	.033	0.85
Z	.189	4.80

**NOTES:**

1. THIS LAND PATTERN IS FOR REFERENCE PURPOSES ONLY. CONSULT YOUR MANUFACTURING GROUP TO ENSURE YOUR COMPANY'S MANUFACTURING GUIDELINES ARE MET.

**Contact Information**

Semtech Corporation  
 Power Management Products Division  
 200 Flynn Road, Camarillo, CA 93012  
 Phone: (805)498-2111 FAX (805)498-3804