

DATA SHEET

SCN2652/SCN68652

Multi-protocol communications controller
(MPCC)

Product specification

1995 May 01

IC19 Data Handbook

Multi-protocol communications controller (MPCC) SCN2652/SCN68652

DESCRIPTION

The SCN2652/68652 Multi-Protocol Communications Controller (MPCC) is a monolithic n-channel MOS LSI circuit that formats, transmits and receives synchronous serial data while supporting bit-oriented or byte control protocols. The chip is TTL compatible, operates from a single +5V supply, and can interface to a processor with an 8 or 16-bit bidirectional data bus.

APPLICATIONS

- Intelligent terminals
- Line controllers
- Network processors
- Front end communications
- Remote data concentrators
- Communication test equipment
- Computer to computer links

FEATURES

- DC to 2Mbps data rate
- Bit-oriented protocols (BOP): SDLC, ADCCP, HDLC
- Byte-control protocols (BCP): DDCMP, BISYNC (external CRC)
- Programmable operation
 - 8 or 16-bit tri-state data bus
 - Error control – CRC or VRC or none
 - Character length – 1 to 8 bits for BOP or 5 to 8 bits for BCP
 - SYNC or secondary station address comparison for BCP-BOP
 - Idle transmission of SYNC/FLAG or MARK for BCP-BOP
- Automatic detection and generation of special BOP control sequences, i.e., FLAG, ABORT, GA
- Zero insertion and deletion for BOP
- Short character detection for last BOP data character
- SYNC generation, detection, and stripping for BCP
- Maintenance mode for self-testing
- TTL compatible
- Single +5V supply

PIN CONFIGURATION

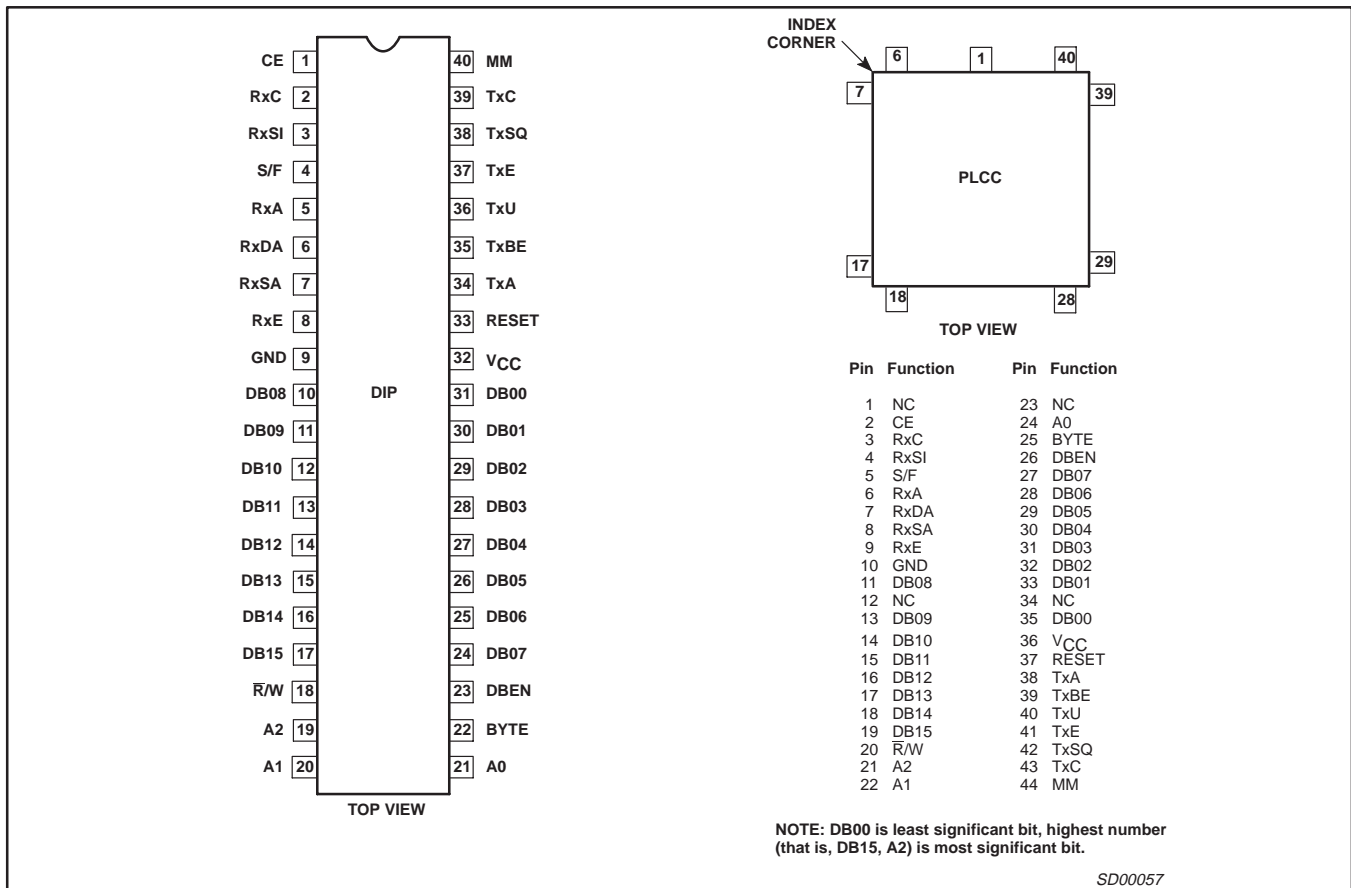

Figure 1. Pin Configuration

Multi-protocol communications controller (MPCC)

SCN2652/SCN68652

ORDERING CODE

PACKAGES	V _{CC} = 5V ±5%		DWG #
	Commercial 0°C to +70°C	Industrial -40°C to +85°C	
40-Pin Ceramic Dual In-Line Package (DIP)	SCN2652AC2F40 / SCN68652AC2F40		0590B
40-Pin Plastic Dual In-Line Package (DIP)	SCN2652AC2N40 / SCN68652AC2N40	Contact Factory	SOT129-1
44-Pin Square Plastic Lead Chip Carrier (PLCC)	SCN2652AC2A44 / SCN68652AC2A44	Contact Factory	SOT187-2

ABSOLUTE MAXIMUM RATINGS¹

SYMBOL	PARAMETER	RATING	UNIT
T _A	Operating ambient temperature ²	Note 4	°C
T _{STG}	Storage temperature	-65 to +150	°C
V _{CC}	All inputs with respect to GND ³	-0.3 to +7	V

NOTES:

1. Stresses above those listed under "Absolute Maximum Ratings" may cause permanent damage to the device. This is a stress rating only and functional operation of the device at these or at any other condition above those indicated in the operation sections of this specification is not implied.
2. For operating at elevated temperatures the device must be derated based on +150°C maximum junction temperature.
3. This product includes circuitry specifically designed for the protection of its internal devices from the damaging effects of excessive static charge. Nonetheless, it is suggested that conventional precautions be taken to avoid applying any voltages larger than the rated maxima.
4. Parameters are valid over operating temperature range unless otherwise specified. See ordering code table for applicable temperature range and operating supply range.

BLOCK DIAGRAM

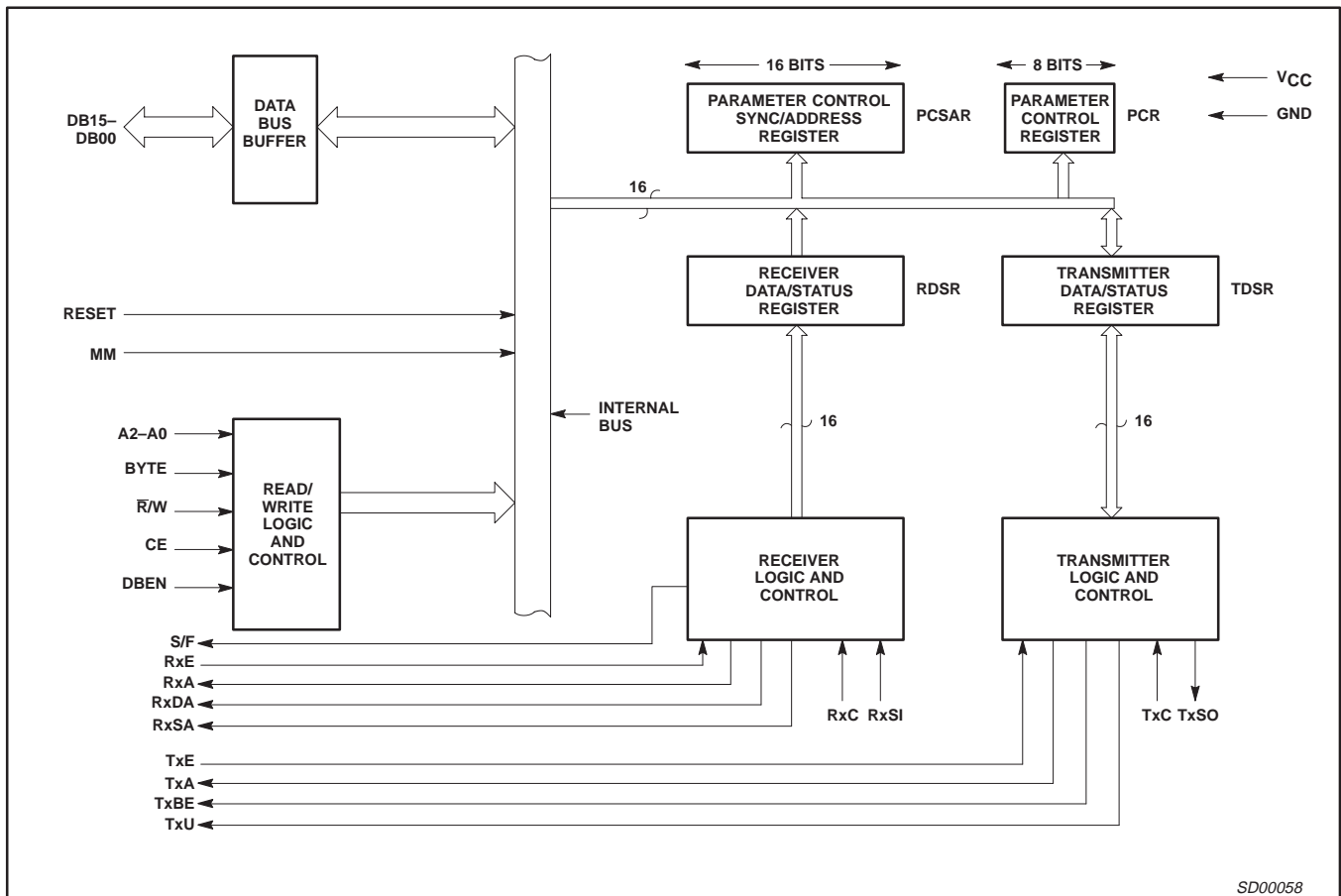

Figure 2. Block Diagram

Multi-protocol communications controller (MPCC)

SCN2652/SCN68652

PIN DESCRIPTION

MNEMONIC	PIN NO.	TYPE	NAME AND FUNCTION
DB15–DB00	17–10 24–31	I/O	Data Bus: DB07–DB00 contain bidirectional data while DB15–DB08 contain control and status information to or from the processor. Corresponding bits of the high and low order bytes can be wire OR'ed onto an 8-bit bus. The data bus is floating if either CE or DBEN are low.
A2–A0	19–21	I	Address Bus: A2–A0 select internal registers. The four 16-bit registers can be addressed on a word or byte basis. See Register Address section.
BYTE	22	I	Byte: Single byte (8-bit) data bus transfers are specified when this input is high. A low level specifies 16-bit data bus transfers.
CE	1	I	Chip Enable: A high input permits a data bus operation when DBEN is activated.
\bar{R}/W	18	I	Read/Write: \bar{R}/W controls the direction of data bus transfer. When high, the data is to be loaded into the addressed register. A low input causes the contents of the addressed register to be presented on the data bus.
DBEN	23	I	Data Bus Enable: After A2–A0, CE, BYTE and \bar{R}/W are set up, DBEN may be strobed. During a read, the 3-state data bus (DB) is enabled with information for the processor. During a write, the stable data is loaded into the addressed register and TxBE will be reset if TDSR was addressed.
RESET	33	I	Reset: A high level initializes all internal registers (to zero) and timing.
MM	40	I	Maintenance Mode: MM internally gates TxSO back to RxSI and TxC to RxC for off line diagnostic purposes. The RxC and RxSI inputs are disabled and TxSO is high when MM is asserted.
RxE	8	I	Receiver Enable: A high level input permits the processing of RxSI data. A low level disables the receiver logic and initializes all receiver registers and timing.
RxA	5	O	Receiver Active: RxA is asserted when the first data character of a message is ready for the processor. In the BOP mode this character is the address. The received address must match the secondary station address if the MPCC is a secondary station. In BCP mode, if strip-SYNC (PCSAR ₁₃) is set, the first non-SYNC character is the first data character; if strip-SYNC is zero, the character following the second SYNC is the first data character. In the BOP mode, the closing FLAG resets RxA. In the BCP mode, RxA is reset by a low level at RxE.
RxDA*	6	O	Receiver Data Available: RxDA is asserted when an assembled character is in RDSR _L and is ready to be presented to the processor. This output is reset when RDSR _L is read.
RxC	2	I	Receiver Clock: RxC (1X) provides timing for the receiver logic. The positive going edge shifts serial data into the RxSR from RxSI.
S/F	4	O	SYNC/FLAG: S/F is asserted for one RxC clock time when a SYNC or FLAG character is detected.
RxSA*	7	O	Receiver Status Available: RxSA is asserted when there is a zero to one transition of any bit in RDSR _H except for RSOM. It is cleared when RDSR _H is read.
RxSI	3	I	Receiver Serial Input: RxSI is the received serial data. Mark = '1', space = '0'.
TxE	37	I	Transmitter Enable: A high level input enables the transmitter data path between TDSR _L and TxSO. At the end of a message, a low level input causes TxSO = 1 (mark) and TxA = 0 after the closing FLAG (BOP) or last character (BCP) is output on TxSO.
TxA	34	O	Transmitter Active: TxA is asserted after TSOM (TDSR ₈) is set and TxE is raised. This output will reset when TxE is low and the closing FLAG (BOP) or last character (BCP) has been output on TxSO.
TxBE*	35	O	Transmitter Buffer Empty: TxBE is asserted when the TDSR is ready to be loaded with new control information or data. The processor should respond by loading the TDSR which resets TxBE.
TxU*	36	O	Transmitter Underrun: TxU is asserted during a transmit sequence when the service of TxBE has been delayed for one character time. This indicates the processor is not keeping up with the transmitter. Line fill depends on PCSAR ₁₁ . TxU is reset by RESET or setting of TSOM (TDSR ₈), synchronized by the falling edge of TxC.
TxC	39	I	Transmitter Clock: TxC (1X) provides timing for the transmitter logic. The positive going edge shifts data out of the TxSR to TxSO.
TxSO	38	O	Transmitter Serial Output: TxSO is the transmitted serial data. Mark = '1', space = '0'.
V _{CC}	32	I	+5V: Power supply.
GND	9	I	Ground: 0V reference ground.

*Indicates possible interrupt signal

Multi-protocol communications controller (MPCC)

SCN2652/SCN68652

Table 1. Register Access

REGISTERS		NO. OF BITS	DESCRIPTION*
Addressable			
PCSAR	Parameter control sync/ address register	16	PCSAR _H and PCR contain parameters common to the receiver and transmitter. PCSAR _L contains a programmable SYNC character (BCP) or secondary station address (BOP).
PCR	Parameter control register	8	RDSR _H contains receiver status information.
RDSR	Receive data/status register	16	RDSR _L = RxDB contains the received assembled character.
TDSR	Transmit data/status register	16	TDSR _H contains transmitter command and status information. TDSR _L = TxDB contains the character to be transmitted
Non-Addressable			
CCSR	Control character shift register	8	These registers are used for character assembly (CCSR, HSR, RxSR), disassembly (TxSR), and CRC accumulation/generation (RxCRC, TxCRC).
HSR	Holding shift register	16	
RxSR	Receiver shift register	8	
TxSR	Transmitter shift register	8	
RxCRC	Receiver CRC accumulation register	16	
TxCRC	Transmitter CRC generation register	16	

NOTES:

*H = High byte – bits 15–8
 L = Low byte – bits 7–0

Table 2. Error Control

CHARACTER	DESCRIPTION
FCS	Frame check sequence is transmitted/received as 16 bits following the last data character of a BOP message. The divisor is usually CRC-CCITT ($X^{16} + X^{12} + X^5 + 1$) with dividend preset to 1's but can be other wise determined by ECM. The inverted remainder is transmitter as the FCS.
BCC	Block check character is transmitted/received as two successive characters following the last data character of a BCP message. The polynomial is CRC-16 ($X^{16} + X^{15} + X^2 + 1$) or CRC-CCITT with dividend preset to 0's (as specified by ECM). The true remainder is transmitted as the BCC.

Table 3. Special Characters

OPERATION	BIT PATTERN	FUNCTION
BOP		
FLAG	01111110	Frame message
ABORT	11111111 generation	Terminate communication
	01111111 detection	
GA	01111111	Terminate loop mode repeater function
Address	(PCSAR _L) ¹	Secondary station address
BCP		
SYNC	(PCSAR _L) or (TxDB) ² generation	Character synchronization

NOTES:

- () = contents of.
- For IDLE = 0 or 1 respectively.

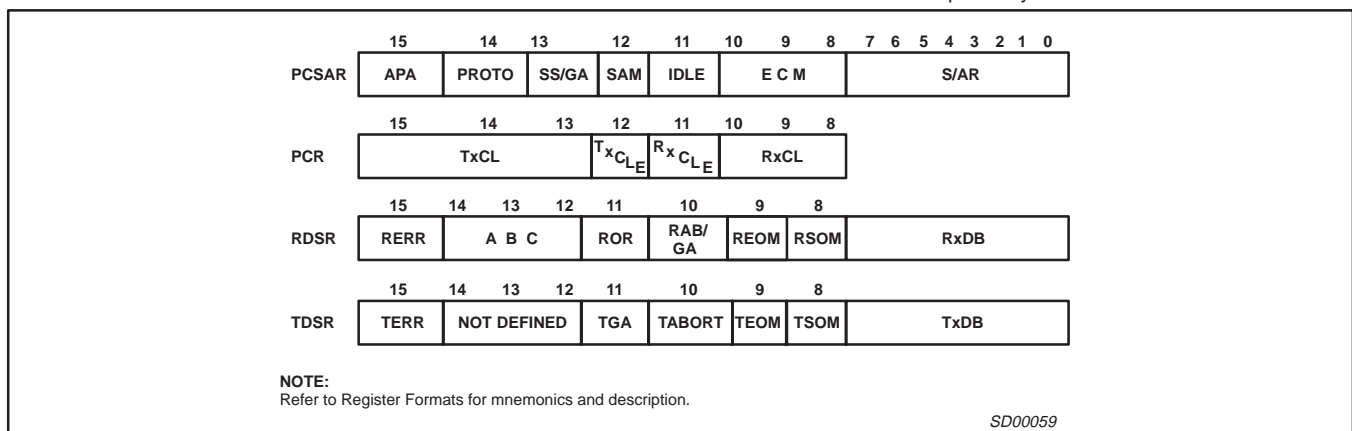

Figure 3. Short Form Register Bit Formats

Multi-protocol communications controller (MPCC)

SCN2652/SCN68652

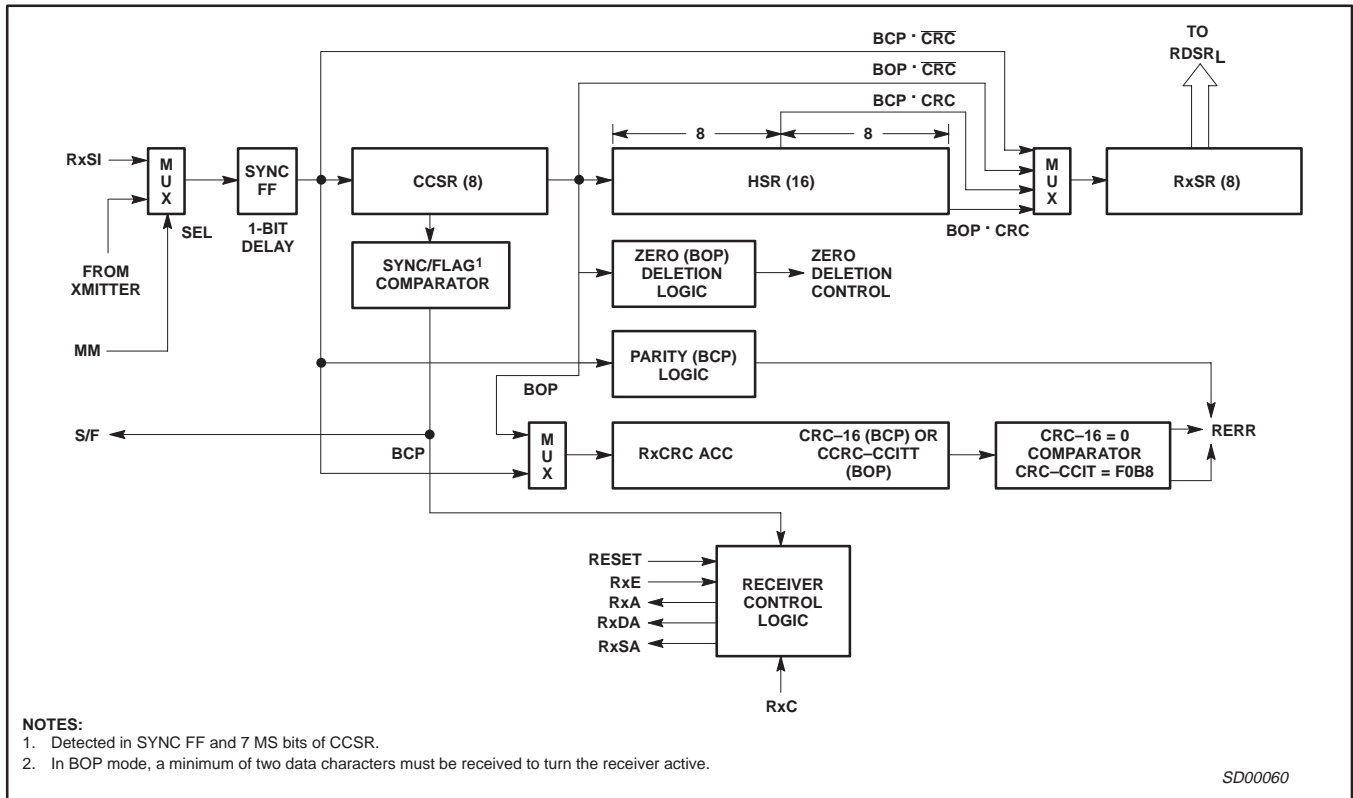

Figure 4. MPCC Receiver Data Path

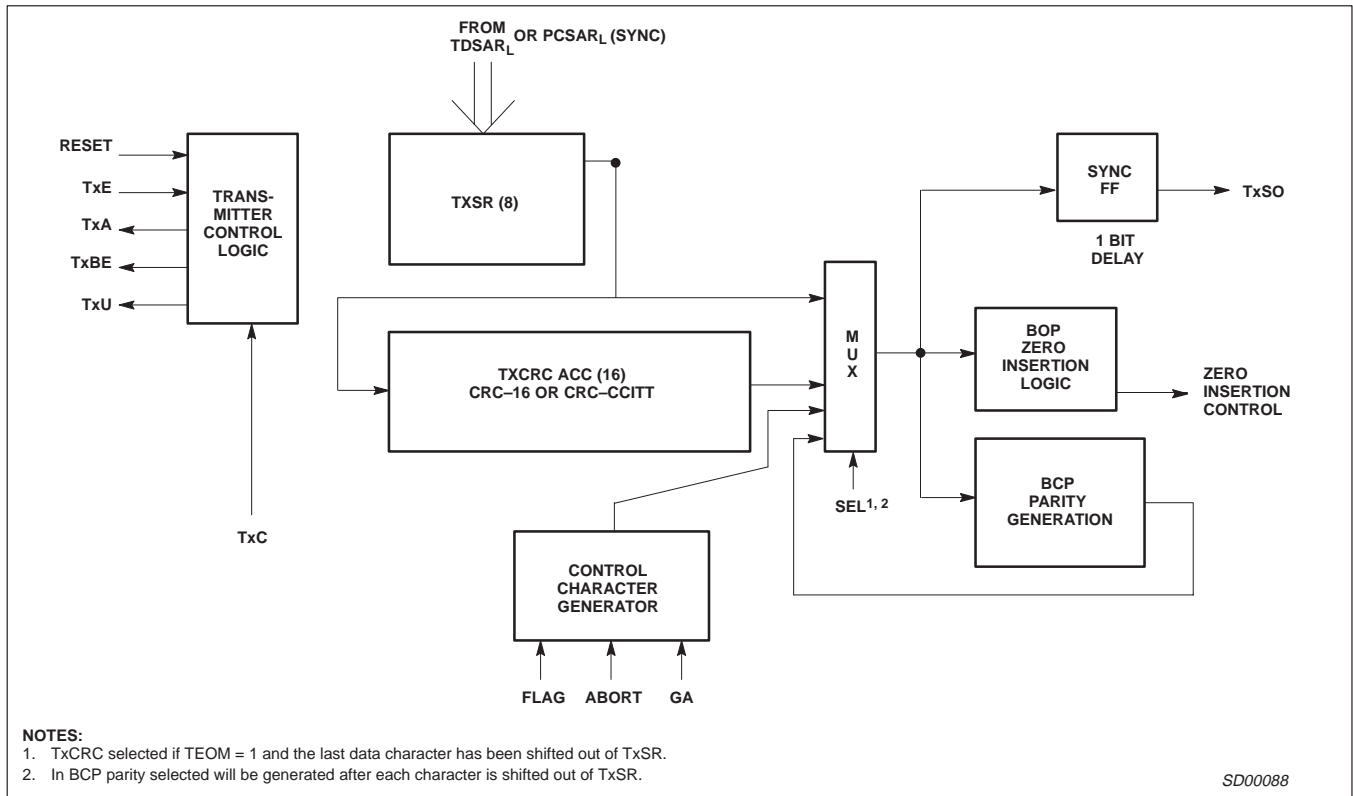

Figure 5. MPCC Transmitter Data Path

Multi-protocol communications controller (MPCC)

SCN2652/SCN68652

FUNCTIONAL DESCRIPTION

The MPCC can be functionally partitioned into receiver logic, transmitter logic, registers that can be read or loaded by the processor, and data bus control circuitry. The register bit formats are shown in Figure 3 while the receiver and transmitter data paths are depicted in Figures 4 and 3.

RECEIVER OPERATION

General

After initializing the parameter control registers (PCSAR and PCR), the Rx_E input must be set high to enable the receiver data path. The serial data on the Rx_{SI} is synchronized and shifted into an 8-bit Control Character Shift Register (CCSR) on the rising edge of Rx_C. A comparison between CCSR contents and the FLAG (BOP) or SYNC (BCP) character is made until a match is found. At that time, the S/F output is asserted for one Rx_C time and the 16-bit Holding Shift Register (HSR) is enabled. The receiver then operates as described below.

BOP Operation

A flowchart of receiver operation in BOP mode appears in Figure 6. Zero deletion (after five ones are received) is implemented on the received serial data so that a data character will not be interpreted as a FLAG, ABORT, or GA. Bits following the FLAG are shifted through the CCSR, HSR, and into the Receiver Shift Register (RxSR). A character will be assembled in the RxSR and transferred to the RDSR_L for presentation to the processor. At that time the Rx_{DA} output will be asserted and the processor must take the character no later than one Rx_C time after the next character is assembled in the RxSR. If not, an overrun (RDSR₁₁ = 1) will occur and succeeding characters will be lost.

The first character following the FLAG is the secondary station address. If the MPCC is a secondary station (PCSAR₁₂ = 1), the contents of RxSR are compared with the address stored in PCSAR_L. A match indicates the forthcoming message is intended for the station; the Rx_A output is asserted, the character is loaded into RDSR_L, Rx_{DA} is asserted and the Receive Start of Message bit (RSOM) is set. No match indicates that another station is being addressed and the receiver searches for the next FLAG.

If the MPCC is a primary station, (PCSAR₁₂ = 0), no secondary address check is made; Rx_A is asserted and RSOM is set once the first non-FLAG character has been loaded into RDSR_L and Rx_{DA} has been asserted. Extended address field can be supported by software if PCSAR₁₂ = 0.

When the 8 bits following the address character have been loaded into RDSR_L and Rx_{DA} has been asserted, RSOM will be cleared. The processor should read this 8-bit character and interpret it as the Control field.

Received serial data that follows is read and interpreted as the information field by the processor. It will be assembled into character lengths as specified by PCR₈₋₁₀. As before, Rx_{DA} is asserted each time a character has been transferred into RDSR_L and is cleared when RDSR_L is read by the processor. RDSR_H should only be read when Rx_{SA} is asserted. This occurs on a zero to one transition of any bit in RDSR_H except for RSOM. Rx_{SA} and all bits in RDSR_H except RSOM are cleared when RDSR_H is read. The processor

should check RDSR₉₋₁₅ each time Rx_{SA} is asserted. If RDSR₉ is set, then RDSR₁₂₋₁₅ should be examined.

Receiver character length may be changed dynamically in response to Rx_{DA}: read the character in Rx_{DB} and write the new character length into Rx_{CL}. The character length will be changed on the next receiver character boundary. A received residual (short) character will be transferred into Rx_{DB} after the previous character in Rx_{DB} has been read, i.e. there will not be an overrun. In general the last two characters are protected from overrun.

The CRC-CCITT, if specified by PCSAR₈₋₁₀, is accumulated in Rx_{CRC} on each character following the FLAG. When the closing FLAG is detected in the CCSR, the received CRC is in the 16-bit HSR. At that time, the Receive End of Message bit (REOM) will be set; Rx_{SA} and Rx_{DA} will be asserted. The processor should read the last data character in RDSR_L and the receiver status in RDSR₉₋₁₅. If RDSR₁₅ = 1, there has been a transmission error; the accumulated CRC-CCITT is incorrect. If RDSR₁₂₋₁₄ ≠ 0, last data character is not of prescribed length. Neither the received CRC nor closing FLAG are presented to the processor. The processor may drop Rx_E or leave it active at the end of the received message.

RxBOP Operation

The operation of the receiver in BCP mode is shown in Figure 7. The receiver initially searches for two successive SYNC characters, of length specified by PCR₈₋₁₀, that match the contents of PCSAR_L. The next non-SYNC character or next SYNC character, if stripping is not specified (PCSAR₁₃ = 0), causes Rx_A to be asserted and enables the receiver data path. Once enabled, all characters are assembled in RxSR and loaded into RDSR_L. Rx_{DA} is active when a character is available in RDSR_L. Rx_{SA} is active on a 0 to 1 transition of any bit in RDSR_H. The signals are cleared when RDSR_I or RDSR_H are read respectively.

If CRC-16 error control is specified by PCSAR₈₋₁₀, the processor must determine the last character received prior to the CRC field. When that character is loaded into RDSR_L and Rx_{DA} is asserted, the received CRC will be in CCSR and HSR_L. To check for a transmission error, the processor must read the receiver status (RDSR_H) and examine RDSR₁₅. This bit will be set for one character time if an error free message has been received. If RDSR₁₅ = 0, the CRC-16 is in error. The state of RDSR₁₅ in BCP CRC mode does not set Rx_{SA}. Note that this bit should be examined only at the end of a message. The accumulated CRC will include all characters starting with the first non-SYNC character if PCSAR₁₃ = 1, or the character after the opening two SYNCs if PCSAR₁₃ = 0. This necessitates external CRC generation/checking when supporting IBM's

BISYNC. This can be accomplished using the Philips Semiconductors SCN2653 Polynomial Generator/Checker. See Typical Applications.

If VRC has been selected for error control, parity (odd or even) is regenerated on each character and checked when the parity bit is received. A discrepancy causes RDSR₁₅ to be set and Rx_{SA} to be asserted. This must be sensed by the processor. The received parity bit is stripped before the character is presented to the processor.

When the processor has read the last character of the message, it should drop Rx_E which disables the receiver logic and initializes all receiver registers and timing.

Multi-protocol communications controller (MPCC)

SCN2652/SCN68652

MPCC, the processor should load TDSR_L with the first character of the message. TSOM should be cleared at the same time TDSR_L is loaded (16-bit data bus) or immediately thereafter (8-bit data bus). FLAGS are sent as long as TSOM = 1. For counting the number of FLAGS, the processor should reassert TSOM in response to the assertion of TxBE. All succeeding characters are loaded into TDSR_L by the processor when TxBE = 1. Each

character is serialized in TxSR and transmitted on TxSO. Internal zero insertion logic stuffs a "0" into the serial bit stream after five successive "1s" are sent. This insures a data character will not match a FLAG, ABORT, or GA reserved control character. As each character is transmitted, the Frame Check Sequence (FCS) is generated as specified by Error Control Mode (PCSAR₈₋₁₀). The FCS should be the CRC-CCITT polynomial ($X^{16} + X^{12} + X^5 + 1$) preset to 1s. If an underrun occurs (processor is not keeping up with the transmitter), TxU and TERR (TDSR₁₅) will be asserted with ABORT or FLAG used as the TxSO line fill depending on the state of IDLE (PCSAR₁₁). The processor must set TSOM to reset the underrun condition. To retransmit the message, the processor should proceed with the normal start of message sequence.

A residual character of 1 to 7 bits may be transmitted at the end of the information field. In response to TxBE, write the residual character length into TxCL and load TxDB with the residual character. Dynamic alteration of character length should be done in exactly the same sequence. The character length will be changed on the next transmit character boundary.

After the last data character has been loaded into TDSR_L and sent to TxSR (TxBE = 1), the processor should set TEOM (TDSR₉). The MPCC will finish transmitting the last character followed by the FCS and the closing FLAG. The processor should clear TEOM and drop TxE when the next TxBE is asserted. This corresponds to the start of closing FLAG transmission. When TxE has been dropped, TxA will be low 1 1/2 bit times after the last bit of the closing FLAG has been transmitted. TxSO will be marked after the closing FLAG has been transmitted.

If TxE and TEOM are high, the transmitter continues to send FLAGS. The processor may initiate the next message by resetting TEOM and setting TSOM, or by loading TDSR_L with a data character and then simply resetting TSOM (without setting TSOM).

TxBP Operation

Transmitter operation for BCP mode is shown in Figure 9. TxA will be asserted after TSOM = 1 and TxE is raised. At that time SYNC characters are sent from PCSAR_L or TDSR_L (IDLE = 0 or 1) as long as TSOM = 1. TxBE is asserted at the start of transmission of the first SYNC character. For counting the number of SYNCs, the processor should reassert TSOM in response to the assertion of TxBE. When TSOM = 0 transmission is from TDSR_L, which must be loaded with characters from the processor each time TxBE is asserted. If this loading is delayed for more than one character time, an underrun results: TxU and TERR are asserted and the

TxSO line fill depend on IDLE (PCSAR₁₁). The processor must set TSOM and retransmit the message to recover. This is not compatible with IBM's BISYNC, so that the user must not underrun when supporting that protocol.

CRC-16, if specified by PCSAR₈₋₁₀, is generated on each character transmitted from TDSR_L when TSOM = 0. The processor must set TEOM = 1 after the last data character has been sent to TxSR (TxBE = 1). The MPCC will finish transmitting the last data character and the CRC-16 field before sending SYNC characters which are transmitted as long as TEOM = 1. If SYNCs are not desired after CRC-16 transmission, the processor should clear TEOM and lower TxE when the TxBE corresponding to the start of CRC-16 transmission is asserted. When TEOM = 0, the line is marked and a new message may be initiated by setting TSOM and raising TxE.

If VRC is specified, it is generated on each data character and the data character length must not exceed 7 bits. For software LRC or CRC, TEOM should be set only if SYNC's are required at the end of the message block.

SPECIAL CASE: The capability to transmit 16 spaces is provided for line turnaround in half duplex mode or for a control recovery situation. This is achieved by setting TSOM and TEOM, clearing TEOM when TxBE = 1, and proceeding as required.

PROGRAMMING

Prior to initiating data transmission or reception, PCSAR and PCR must be loaded with control information from the processor. The contents of these registers (see Register Format section) will configure the MPCC for the user's specific data communication environment. These registers should be loaded during power-on initialization and after a reset operation. They can be changed at any time that the respective transmitter or receiver is disabled.

The default value for all registers is zero. This corresponds to BOP, primary station mode, 8-bit character length, FCS = CRC-CCITT preset to 1s.

For BOP mode the character length register (PCR) may be set to the desired values during system initialization. The address and control fields will automatically be 8-bits. If a residual character is to be transmitted, TxCL should be changed to the residual character length prior to transmission of that character.

DATA BUS CONTROL

The processor must set up the MPCC register address (A2-A0), chip enable (CE), byte select (BYTE), and read/write (R/W) inputs before each data bus transfer operation.

During a read operation ($\bar{R}/W = 0$), the leading edge of DBEN will initiate an MPCC read cycle. The addressed register will place its contents on the data bus. If BYTE = 1, the 8-bit byte is placed on DB15-08 or DB07-00 depending on the H/L status of the register addressed. Unused bits in RDSR_L are zero. If BYTE = 0, all 16 bits (DB15-00) contain MPCC information. The trailing edge of DBEN will reset RxDA and/or RxSA if RDSR_L or RDSR_H is addressed respectively.

DBEN acts as the enable and strobe so that the MPCC will not begin its internal read cycle until DBEN is asserted.

During a write operation ($\bar{R}/W = 1$), data must be stable on DB15-08 and/or DB07-00 prior to the leading edge of DBEN. The stable data is strobed into the addressed register by DBEN. TxBE will be cleared if the addressed register was TDSR_H or TDSR_L.

Multi-protocol communications controller (MPCC)

SCN2652/SCN68652

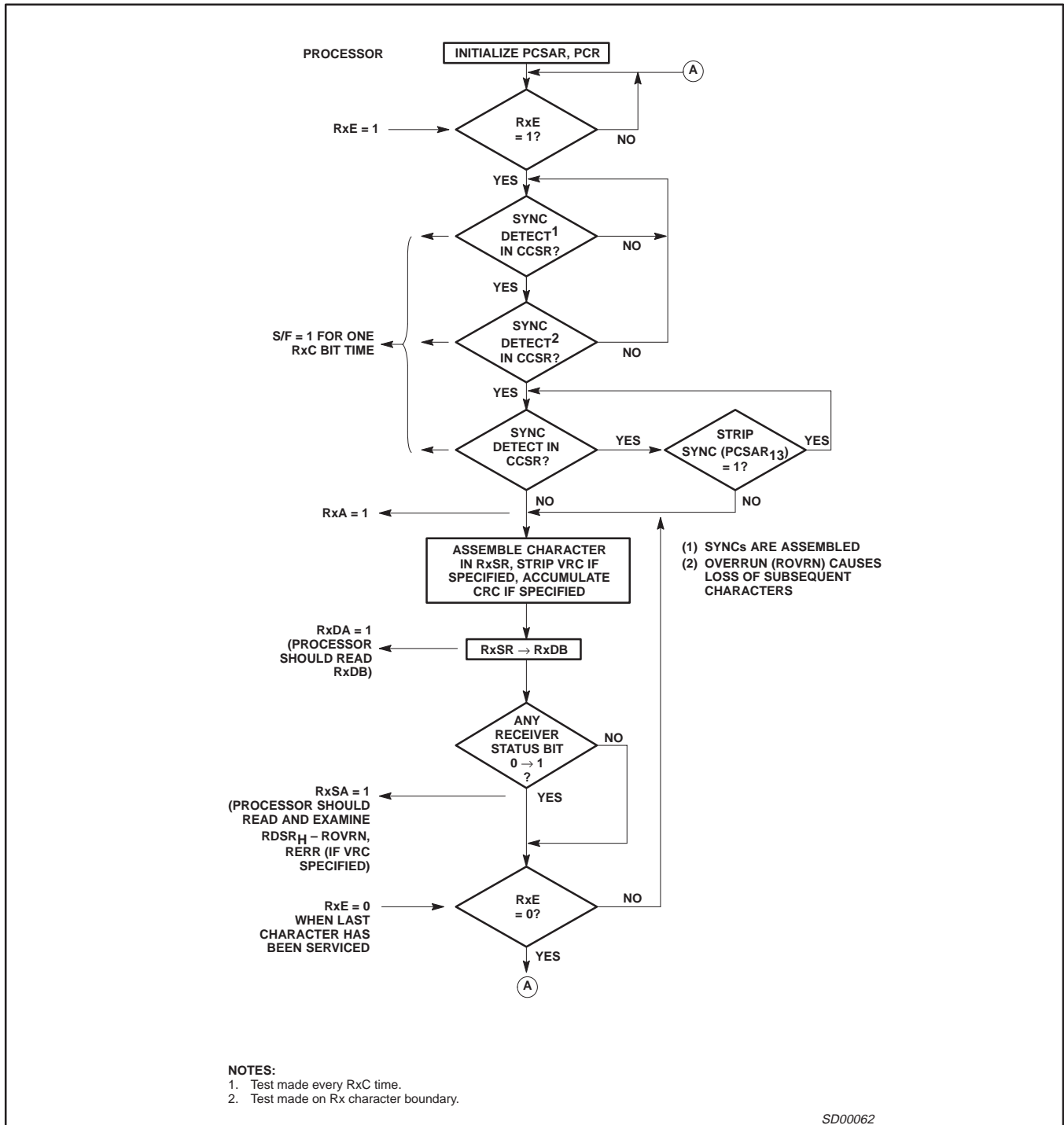
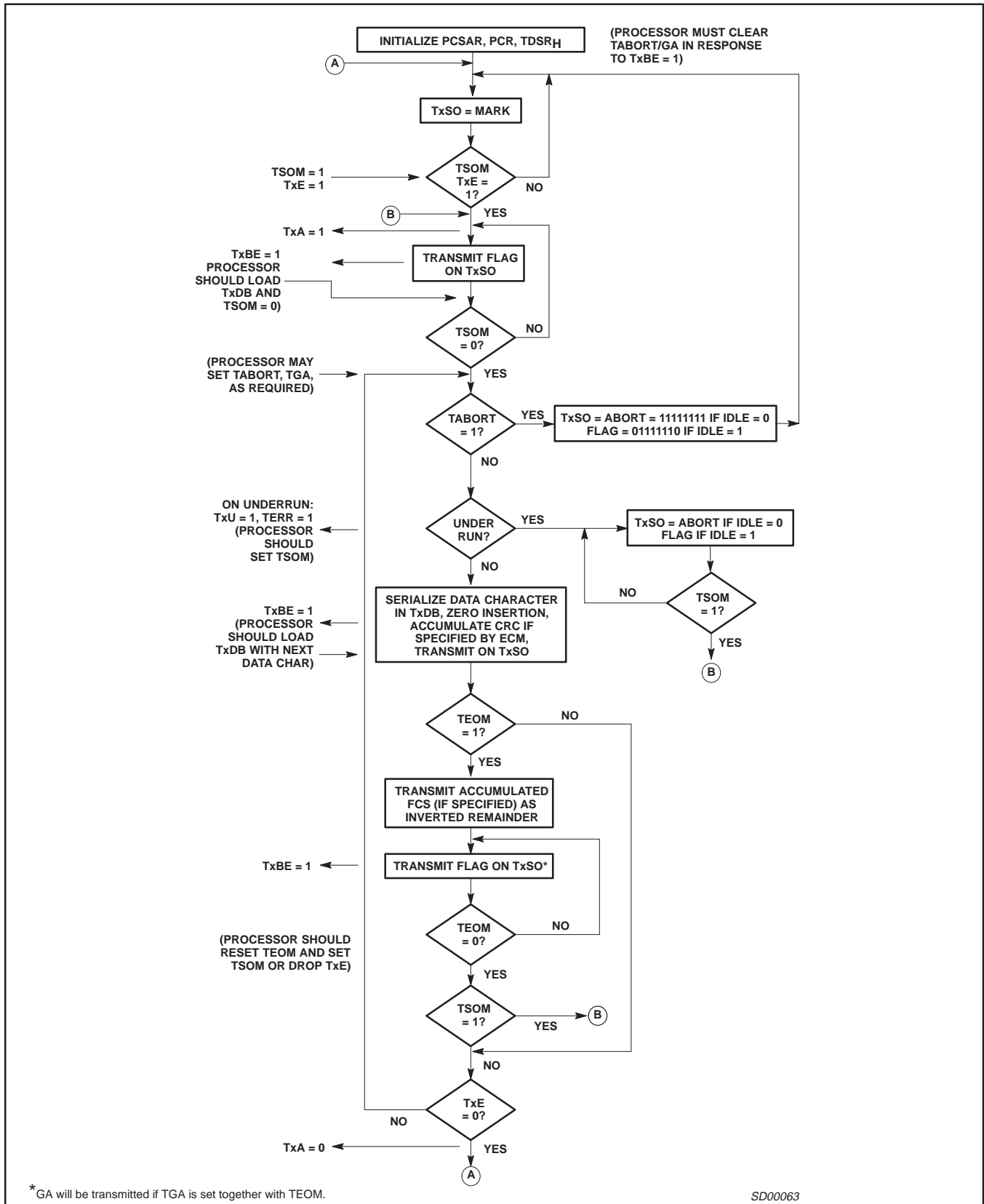

Figure 7. BCP Receive

Multi-protocol communications controller (MPCC)

SCN2652/SCN68652



*GA will be transmitted if TGA is set together with TEOM.

SD00063

Figure 8. BOP Transmit

Multi-protocol communications controller (MPCC)

SCN2652/SCN68652

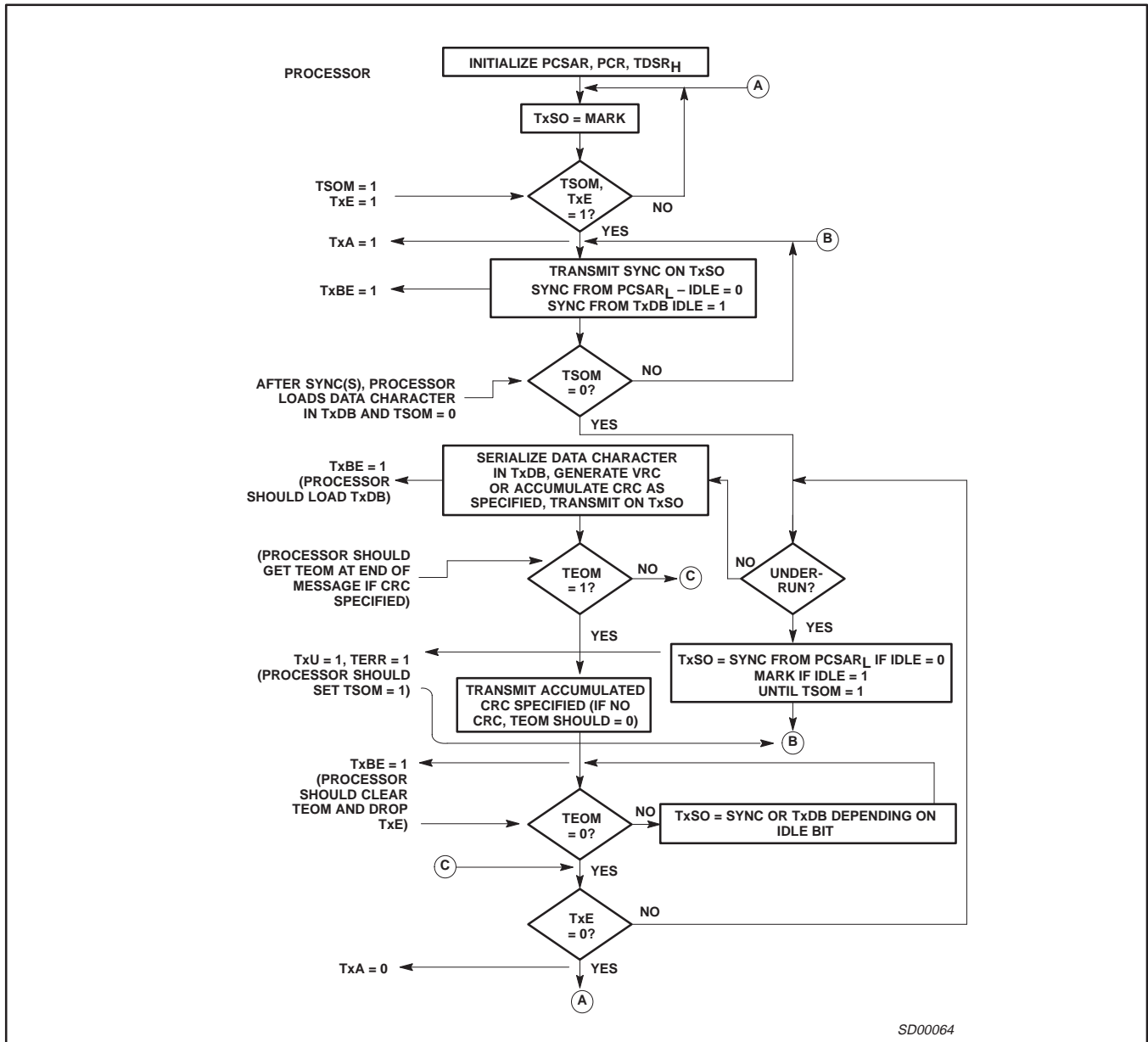

Figure 9. BCP Transmit

SD00064

Multi-protocol communications controller (MPCC)

SCN2652/SCN68652

Table 4. MPCC Register Addressing

	A2	A1	A0	REGISTER
Byte = 0 (16-Bit Data Bus = DB₁₅ – DB₀₀)				
	0	0	X	RDSR
	0	1	X	TDSR
	1	0	X	PCSAR
	1	1	X	PCR*
Byte = 1 (8-Bit Data Bus = DB₇₋₀ or DB₁₅₋₈**)				
	0	0	0	RDSR _L
	0	0	1	RDSR _H
	0	1	0	TDSR _L
	0	1	1	TDSR _H
	1	0	0	PCSAR _L
	1	0	1	PCSAR _H
	1	1	0	PCR _L *
	1	1	1	PCR _H

NOTES:

- * PCR lower byte does not exist. It will be all "0"s when read.
- ** Corresponding high and low order pins must be tied together.

Table 5. Parameter Control Register (PCR)–(R/W)

BIT	NAME	MODE	FUNCTION																																				
00–07	Not Defined																																						
08–10	RxCL	BOP/BCP	Receiver character length is loaded by the processor when RxCLE = 0. The character length is valid after transmission of single byte address and control fields have been received. <table border="1" style="margin-left: auto; margin-right: auto;"> <thead> <tr> <th>10</th> <th>9</th> <th>8</th> <th>Char length (bits)</th> </tr> </thead> <tbody> <tr> <td>0</td> <td>0</td> <td>0</td> <td>8</td> </tr> <tr> <td>0</td> <td>0</td> <td>1</td> <td>1</td> </tr> <tr> <td>0</td> <td>1</td> <td>0</td> <td>2</td> </tr> <tr> <td>0</td> <td>1</td> <td>1</td> <td>3</td> </tr> <tr> <td>1</td> <td>0</td> <td>0</td> <td>4</td> </tr> <tr> <td>1</td> <td>0</td> <td>1</td> <td>5</td> </tr> <tr> <td>1</td> <td>1</td> <td>0</td> <td>6</td> </tr> <tr> <td>1</td> <td>1</td> <td>1</td> <td>7</td> </tr> </tbody> </table>	10	9	8	Char length (bits)	0	0	0	8	0	0	1	1	0	1	0	2	0	1	1	3	1	0	0	4	1	0	1	5	1	1	0	6	1	1	1	7
10	9	8	Char length (bits)																																				
0	0	0	8																																				
0	0	1	1																																				
0	1	0	2																																				
0	1	1	3																																				
1	0	0	4																																				
1	0	1	5																																				
1	1	0	6																																				
1	1	1	7																																				
11	RxCLE	BOP/BCP	Receiver character length enable should be zero when the processor loads RxCL. The remaining bits of PCR are not affected during loading. Always 0 when read.																																				
12	TxCLE	BOP/BCP	Transmitter character length enable should be zero when the processor loads TxCL. The remaining bits of PCR are not affected during loading. Always 0 when read.																																				
13–15	TxCL	BOP/BCP	Transmitter character length is loaded by the processor when TxCLE = 0. Character bit length specification format is identical to RxCL. It is valid after transmission of single byte address and control fields.																																				

Multi-protocol communications controller (MPCC)

SCN2652/SCN68652

Table 6. Parameter Control SYNC/Address Register (PCSAR)–(R/W)

BIT	NAME	MODE	FUNCTION																																																						
00–07	S/AR	BOP BCP	SYNC/address register. Contains the secondary station address if the MPCC is a secondary station. The contents of this register is compared with the first received non-FLAG character to determine if the message is meant for this station. SYNC character is loaded into this register by the processor. It is used for receive and transmit bit synchronization with bit length specified by RxCL and TxCL.																																																						
08–10	ECM	BOP/BCP	<table border="1"> <thead> <tr> <th>Error Control Mode</th> <th>10</th> <th>9</th> <th>8</th> <th>Suggested Mode</th> <th>Char. length</th> </tr> </thead> <tbody> <tr> <td>CRC–CCITT preset to 1's</td> <td>0</td> <td>0</td> <td>0</td> <td>BOP</td> <td>1–8</td> </tr> <tr> <td>CRC–CCITT preset to 0's</td> <td>0</td> <td>0</td> <td>1</td> <td>BCP</td> <td>8</td> </tr> <tr> <td>Not used</td> <td>0</td> <td>1</td> <td>0</td> <td>—</td> <td>—</td> </tr> <tr> <td>CRC–16 preset to 0's</td> <td>0</td> <td>1</td> <td>1</td> <td>BCP</td> <td>8</td> </tr> <tr> <td>VRC odd</td> <td>1</td> <td>0</td> <td>0</td> <td>BCP</td> <td>5–7</td> </tr> <tr> <td>VRC even</td> <td>1</td> <td>0</td> <td>1</td> <td>BCP</td> <td>5–7</td> </tr> <tr> <td>Not used</td> <td>1</td> <td>1</td> <td>0</td> <td>—</td> <td>—</td> </tr> <tr> <td>No error control</td> <td>1</td> <td>1</td> <td>1</td> <td>BCP/BOP</td> <td>5–8</td> </tr> </tbody> </table> ECM should be loaded by the processor during initialization or when both data paths are idle.	Error Control Mode	10	9	8	Suggested Mode	Char. length	CRC–CCITT preset to 1's	0	0	0	BOP	1–8	CRC–CCITT preset to 0's	0	0	1	BCP	8	Not used	0	1	0	—	—	CRC–16 preset to 0's	0	1	1	BCP	8	VRC odd	1	0	0	BCP	5–7	VRC even	1	0	1	BCP	5–7	Not used	1	1	0	—	—	No error control	1	1	1	BCP/BOP	5–8
Error Control Mode	10	9	8	Suggested Mode	Char. length																																																				
CRC–CCITT preset to 1's	0	0	0	BOP	1–8																																																				
CRC–CCITT preset to 0's	0	0	1	BCP	8																																																				
Not used	0	1	0	—	—																																																				
CRC–16 preset to 0's	0	1	1	BCP	8																																																				
VRC odd	1	0	0	BCP	5–7																																																				
VRC even	1	0	1	BCP	5–7																																																				
Not used	1	1	0	—	—																																																				
No error control	1	1	1	BCP/BOP	5–8																																																				
11	IDLE	BOP BCP	Determines line fill character to be used if transmitter underrun occurs (TxU asserted and TERR set) and transmission of special characters for BOP/BCP. IDLE = 0, transmit ABORT characters during underrun and when TABORT = 1. IDLE = 1, transmit FLAG characters during underrun and when TABORT = 1. IDLE = 0 transmit initial SYNC characters and underrun line fill characters from the S/AR. IDLE = 1 transmit initial SYNC characters from TxDB and marks TxSO during underrun.																																																						
12	SAM	BOP	Secondary Address Mode = 1 if the MPCC is a secondary station. This facilitates automatic recognition of the received secondary station address. When transmitting, the processor must load the secondary address into TxDB. SAM = 0 inhibits the received secondary address comparison which serves to activate the receiver after the first non-FLAG character has been received.																																																						
13	SS/GA	BOP BCP	Strip SYNC/Go Ahead. Operation depends on mode. SS/GA = 1 is used for loop mode only and enables GA detection. When a GA is detected as a closing character, REOM and RAB/GA will be set and the processor should terminate the repeater function. SS/GA = 0 is the normal mode which enables ABORT detection. It causes the receiver to terminate the frame upon detection of an ABORT or FLAG. SS/GA = 1, causes the receiver to strip SYNC's immediately following the first two SYNC's detected. SYNC's in the middle of a message will not be stripped. SS/GA = 0, presents any SYNC's after the initial two SYNC's to the processor.																																																						
14	PROTO	BOP BCP	Determines MPCC Protocol mode PROTO = 0 PROTO = 1																																																						
15	APA	BOP	All parties address. If this bit is set, the receiver data path is enabled by an address field of '11111111' as well as the normal secondary station address.																																																						

Multi-protocol communications controller (MPCC)

SCN2652/SCN68652

Table 7. Transmit Data/Status Register (TDSR) (R/W except TDSR15)

BIT	NAME	MODE	FUNCTION
00–07	TxDB	BOP/BCP	Transmit data buffer. Contains processor loaded characters to be serialized in TxSR and transmitted on TxSO.
08	TSOM	BOP BCP	Transmitter start of message. Set by the processor to initiate message transmission provided TxE = 1. TSOM = 1 generates FLAGs. When TSOM = 0 transmission is from TxDB and FCS generation (if specified) begins. FCS, as specified by PCSAR _{8–10} , should be CRC–CCITT preset to 1's. TSOM = 1 generates SYNCs from PCSAR _L or transmits from TxDB for IDLE = 0 or 1 respectively. When TSOM = 0 transmission is from TxDB and CRC generation (if specified) begins.
09	TEOM	BOP BCP	Transmit end of message. Used to terminate a transmitted message. TEOM = 1 causes the FCS and the closing FLAG to be transmitted following the transmission of the data character in TxSR. FLAGs are transmitted until TEOM = 0. ABORT or GA are transmitted if TABORT or TGA are set when TEOM = 1. TEOM = 1 causes CRC–16 to be transmitted (if selected) followed by SYNCs from PCSAR _L or TxDB (IDLE = 0 or 1). Clearing TEOM prior to the end of CRC–16 transmission (when TxBE = 1) causes TxSO to be marked following the CRC–16. TxE must be dropped before a new message can be initiated. If CRC is not selected, TEOM should not be set.
10	TABORT	BOP	Transmitter abort = 1 will cause ABORT or FLAG to be sent (IDLE = 1 or 1) after the current character is transmitted. (ABORT = 11111111)
11	TGA	BOP	Transmit go ahead (GA) instead of FLAG when TEOM = 1. This facilitates repeater termination in loop mode. (GA = 01111111)
12–14	Not Defined		
15	TERR	Read only BOP BCP	Transmitter error = 1 indicates the TxDB has not been loaded in time (one character time–1/2 TxC period after TxBE is asserted) to maintain continuous transmission. TxU will be asserted to inform the processor of this condition. TERR is cleared by setting TSOM. See timing diagram. ABORT's or FLAG's are sent as fill characters (IDLE = 0 or 1) SYNC's or MARK's are sent as fill characters (IDLE = 0 or 1). For IDLE = 1 the last character before underrun is not valid.

Multi-protocol communications controller (MPCC)

SCN2652/SCN68652

Table 8. Receiver Data/Status Register (RDSR)–(Read Only)

BIT	NAME	MODE	FUNCTION
00–07	RxDB	BOP/BCP	Receiver data buffer. Contains assembled characters from the RxSR. If VRC is specified, the parity bit is stripped.
08	RSOM	BOP	Receiver start of message = 1 when a FLAG followed by a non-FLAG has been received and the latter character matches the secondary station if SAM = 1. RxA will be asserted when RSOM = 1. RSOM resets itself after one character time and has no affect on RxSA.
09	REOM	BOP	Receiver end of message = 1 when the closing FLAG is detected and the last data character is loaded into RxDB or when an ABORT/GA character is received. REOM is cleared on reading RDSR _H , reset operation, or dropping of RxE.
10	RAB/GA	BOP	Received ABORT or GA character = 1 when the receiver senses an ABORT character if SS/GA = 0 or a GA character if SS/GA = 1. RAB/GA is cleared on reading RDSR _H , reset operation, or dropping of RxE. A received abort does not set RxDA.
11	ROR	BOP/BCP	Receiver overrun = 1 indicates the processor has not read last character in the RxDB within one character time + 1/2 RxC period after RxDA is asserted. Subsequent characters will be lost. ROR is cleared on reading RDSR _H , reset operation, or dropping of RxE.
12–14	ABC	BOP	Assembled bit count. Specifies the number of bits in the last received data character of a message and should be examined by the processor when REOM = 1 (RxDA and RxSA asserted). ABC = 0 indicates the message was terminated (by a flag or GA) on a character boundary as specified by PCR _{8–10} . Otherwise, ABC = number of bits in the last data character. ABC is cleared when RDSR _H is read, reset operation, or dropping RxE. The residual character is right justified in RDSL.
15	RERR	BOP/BCP	Receiver error indicator should be examined by the processor when REOm = 1 in BOP, or when the processor determines the last data character of the message in BCP with CRC or when RxSA is set in BCP with VRC. CRC–CCITT preset to 1's/0's as specified by PCSAR _{8–10} : RERR = 1 indicates FCS error (CRC ≠ F0B8 or ≠ 0) RERR = 0 indicates FCS received correctly (CRC = F0B8 or = 0) CRC–16 preset to 0's on 8-bit characters specified by PSCAR _{8–10} : RERR = 1 indicates CRC–16 received correctly (CRC = 0). RERR = 0 indicates CRC–16 error (CRC ≠ 0) VRC specified by PCSAR _{8–10} : RERR = 1 indicates VRC error RERR = 0 indicates VRC is correct.

DC ELECTRICAL CHARACTERISTICS^{1, 2}

PARAMETER	TEST CONDITIONS	LIMITS			UNIT
		Min	Typ	Max	
Input voltage V _{IL} Low V _{IH} High		2.0		0.8	V
Output voltage V _{OL} Low V _{OH} High	I _{OL} = 1.6mA I _{OH} = –100µA	2.4		0.4	V
I _{CC} Power supply current	V _{CC} = 5.25V, T _A = 0°C			150	mA
Leakage current I _{IL} Input I _{OL} Output	V _{IN} = 0 to 5.25V V _{OUT} = 0 to 5.25V			10 10	µA
Capacitance C _{IN} Input C _{OUT} Output	V _{IN} = 0V, f = 1MHz V _{OUT} = 0V, f = 1MHz			20 20	pF

Multi-protocol communications controller (MPCC)

SCN2652/SCN68652

AC ELECTRICAL CHARACTERISTICS^{1, 2, 3}

PARAMETER	2MHz CLOCK			UNIT
	Min	Typ	Max	
Set-up and hold time				
t _{ACS} Address/control set-up	50			ns
t _{ACH} Address/control hold	0			
t _{DS} Data bus set-up (write)	50			
t _{DH} Data bus hold (write)	0			
t _{RXS} Receiver serial data set-up	150			
t _{RxH} Receiver serial data hold	150			
Pulse width				
t _{RES} RESET	250			ns
t _{DBEN} DBEN	250		m ⁴	
Delay Time				
t _{DD} Data bus (read)			170	ns
t _{TxD} Transmit serial data			250	
t _{DBEND} DBEN to DBEN delay	200			
t _{DF} Data bus float time (read)			150	ns
f Clock (RxC, TxC) frequency			2.0	MHz
t _{CLK1} Clock high (MM = 0)	165			ns
t _{CLK2} Clock high (MM = 1)	240			
t _{CLK0} Clock low	240			

NOTES:

- Parameters are valid over operating temperature range unless otherwise specified. See ordering code table for applicable temperature range and operating supply range.
- All voltage measurements are referenced to ground. All time measurements are at 0.8V or 2.0V. Input voltage levels for testing are 0.4V and 2.4V.
- Output load C_L = 100pF.
- m = TxC low and applies to writing to TDSRH only.

TIMING DIAGRAMS

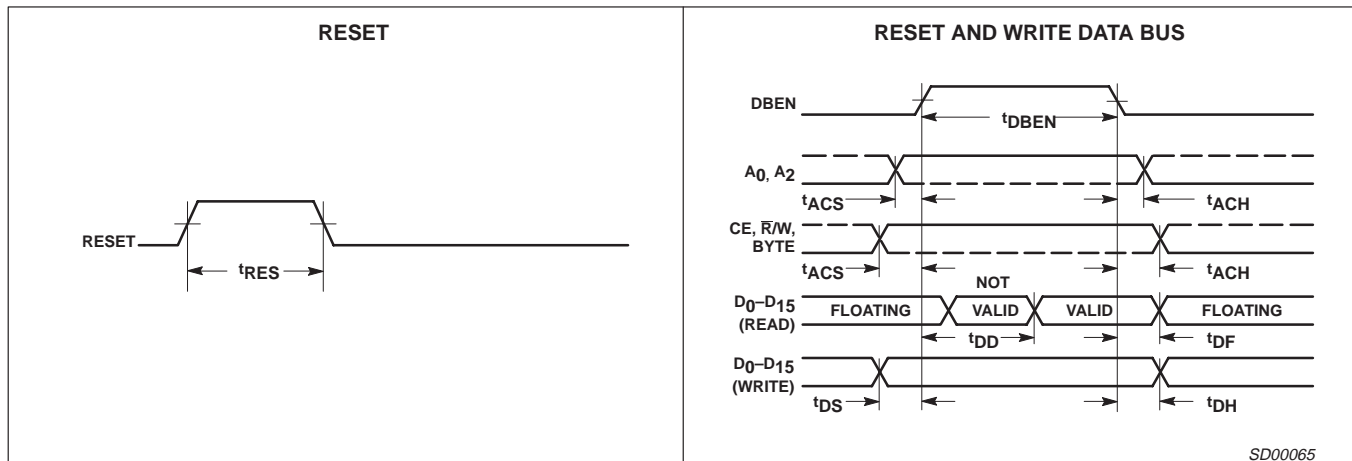

Figure 10. Timing Diagrams

Multi-protocol communications controller (MPCC)

SCN2652/SCN68652

TIMING DIAGRAMS (Continued)

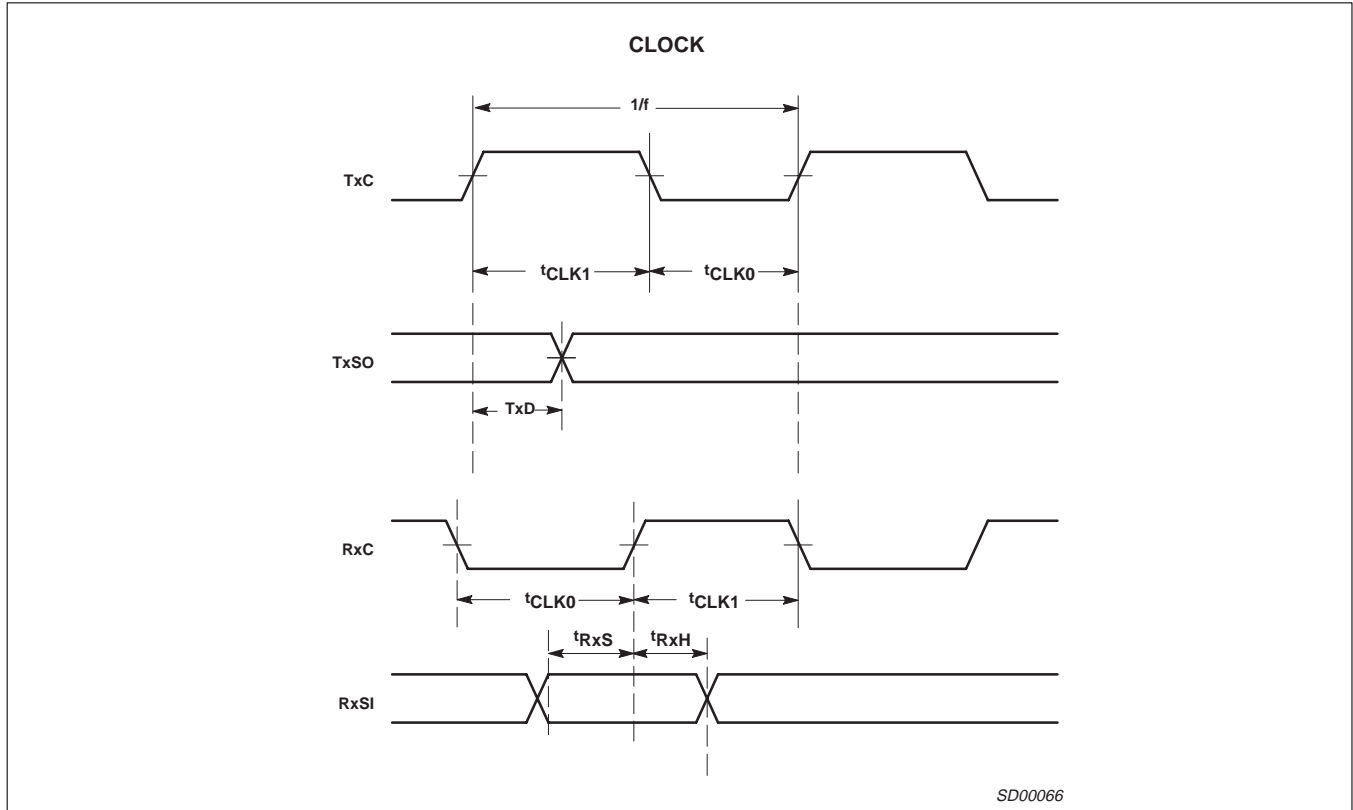
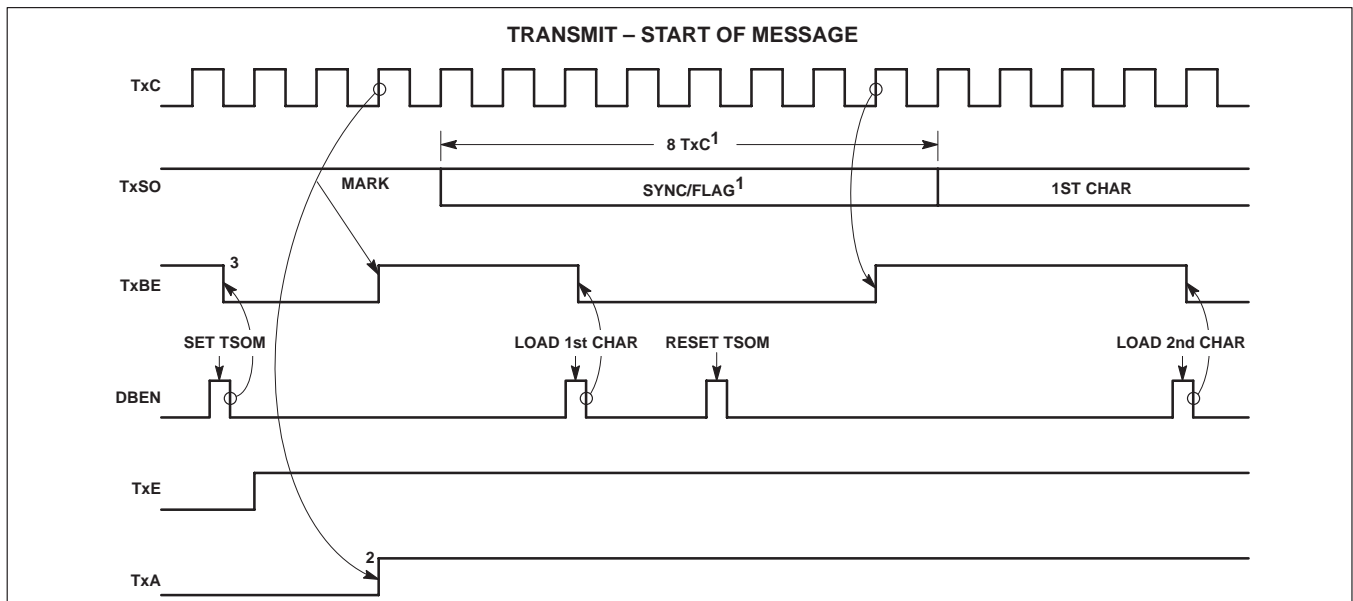

Figure 11. Timing Diagrams (cont.)



NOTES:

1. SYNC may be 5 to 8 bits and will contain parity bit as specified.
2. TxA goes high relative to TxC rising edge after TSOM has been set and TxE has been raised.
3. TxBE goes low relative to DBEN falling edge on the first write transfer into TDSR. It is reasserted 1 TxC time before the first bit of the transmitted SYNC/FLAG. TxBE then goes low relative to DBEN falling edge when writing into TDSR_H and/or TDSR_L. It is reasserted on the rising edge of the TxC that corresponds to the transmission of the last bit of each character, except in BOP mode when the CRC is to be sent as the next character (see Transmit Timing—End of Message).

SD00067

Figure 12. Timing Diagrams (cont.)

Multi-protocol communications controller (MPCC)

SCN2652/SCN68652

TIMING DIAGRAMS (Continued)

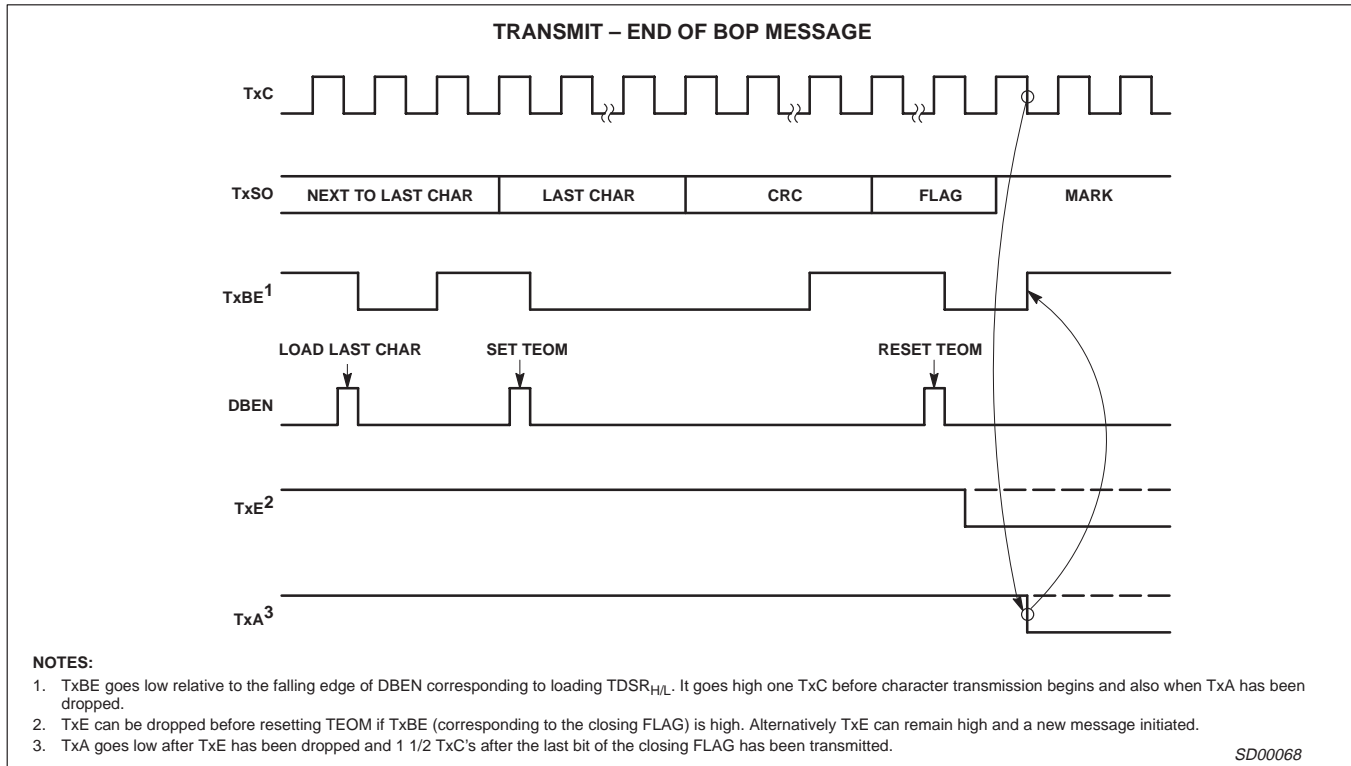

Figure 13. Timing Diagrams (cont.)

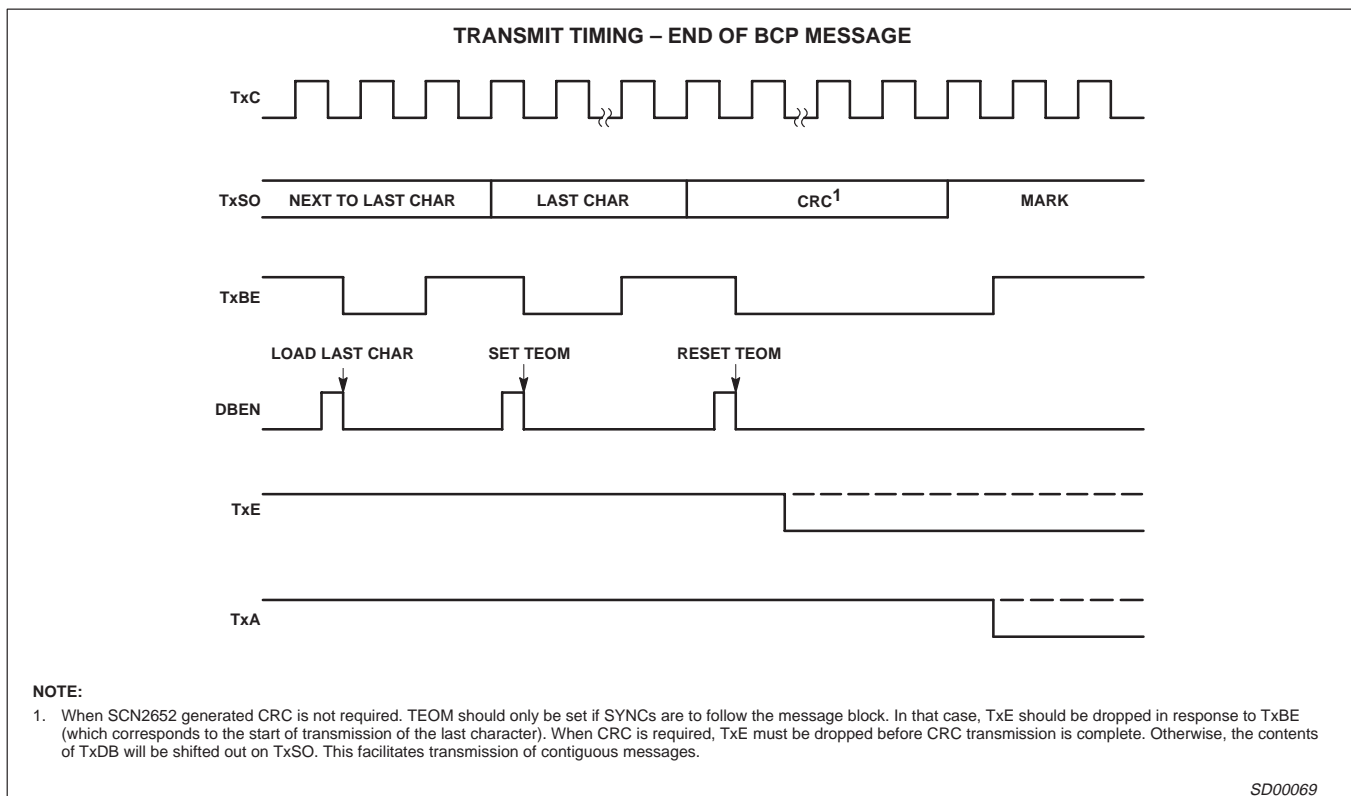

Figure 14. Timing Diagrams (cont.)

Multi-protocol communications controller (MPCC)

SCN2652/SCN68652

TIMING DIAGRAMS (Continued)

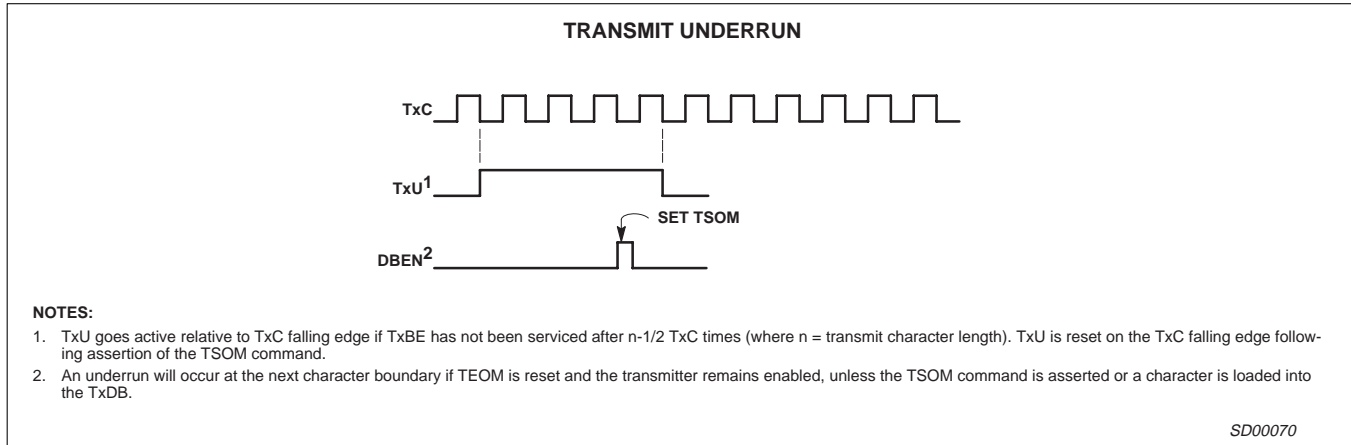

Figure 15. Timing Diagrams (cont.)

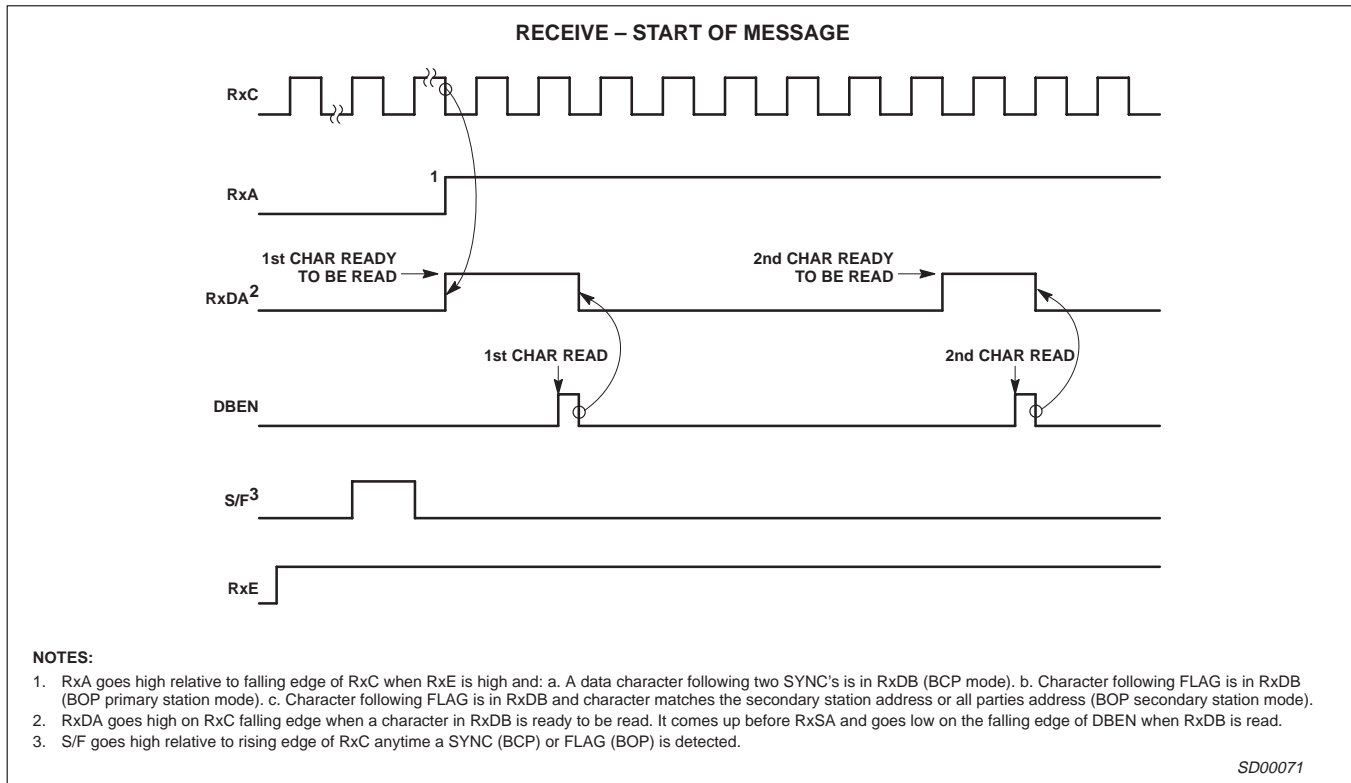

Figure 16. Timing Diagrams (cont.)

Multi-protocol communications controller (MPCC)

SCN2652/SCN68652

TIMING DIAGRAMS (Continued)

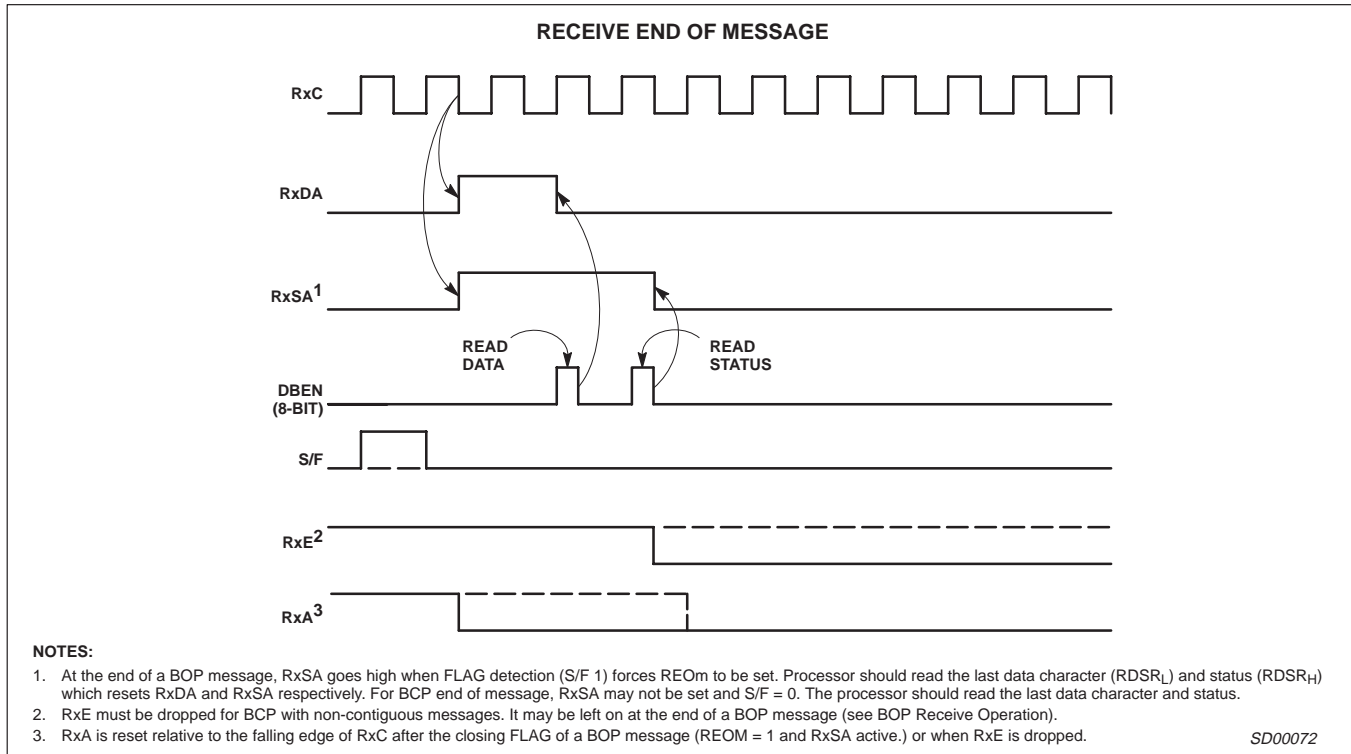

Figure 17. Timing Diagrams (cont.)

TYPICAL APPLICATIONS

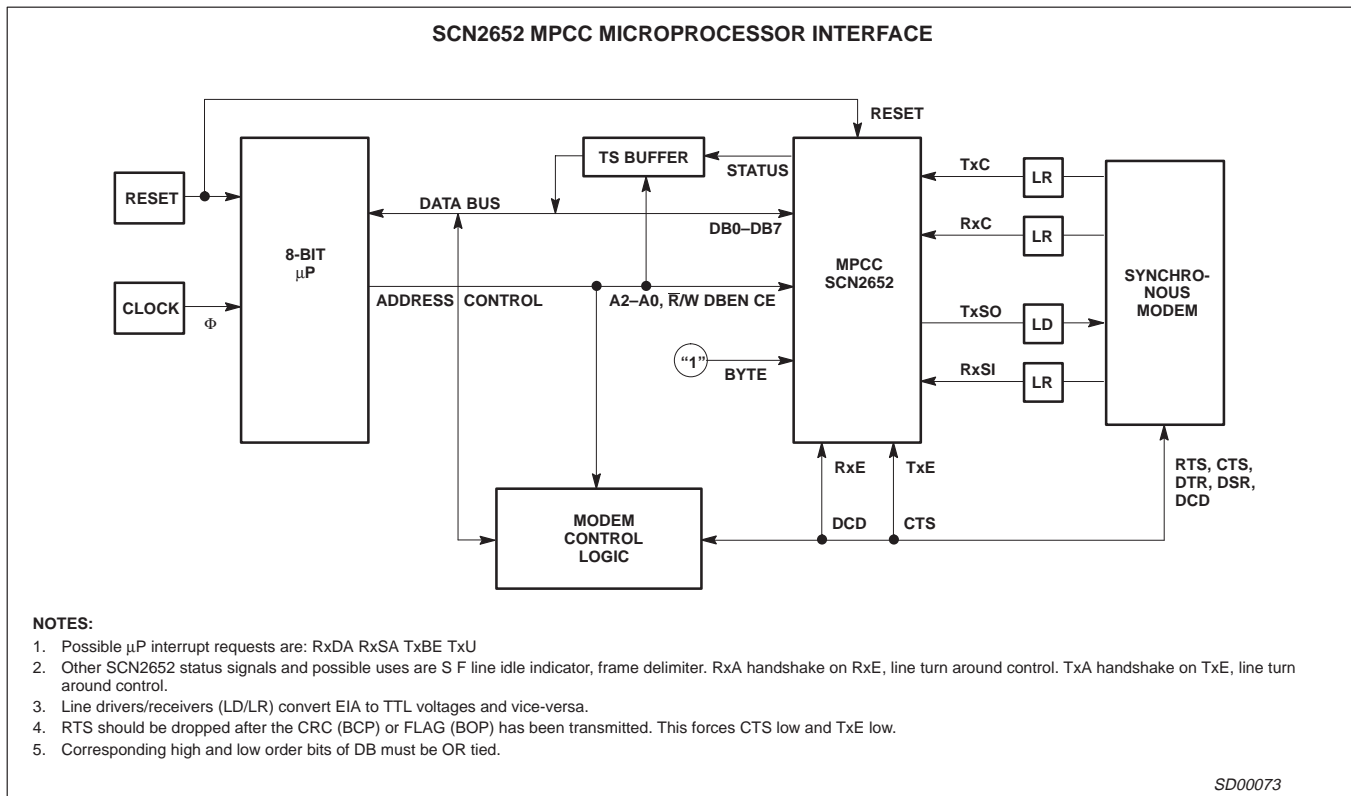

Figure 18. Typical Applications

Multi-protocol communications controller (MPCC)

SCN2652/SCN68652

TYPICAL APPLICATIONS (Continued)

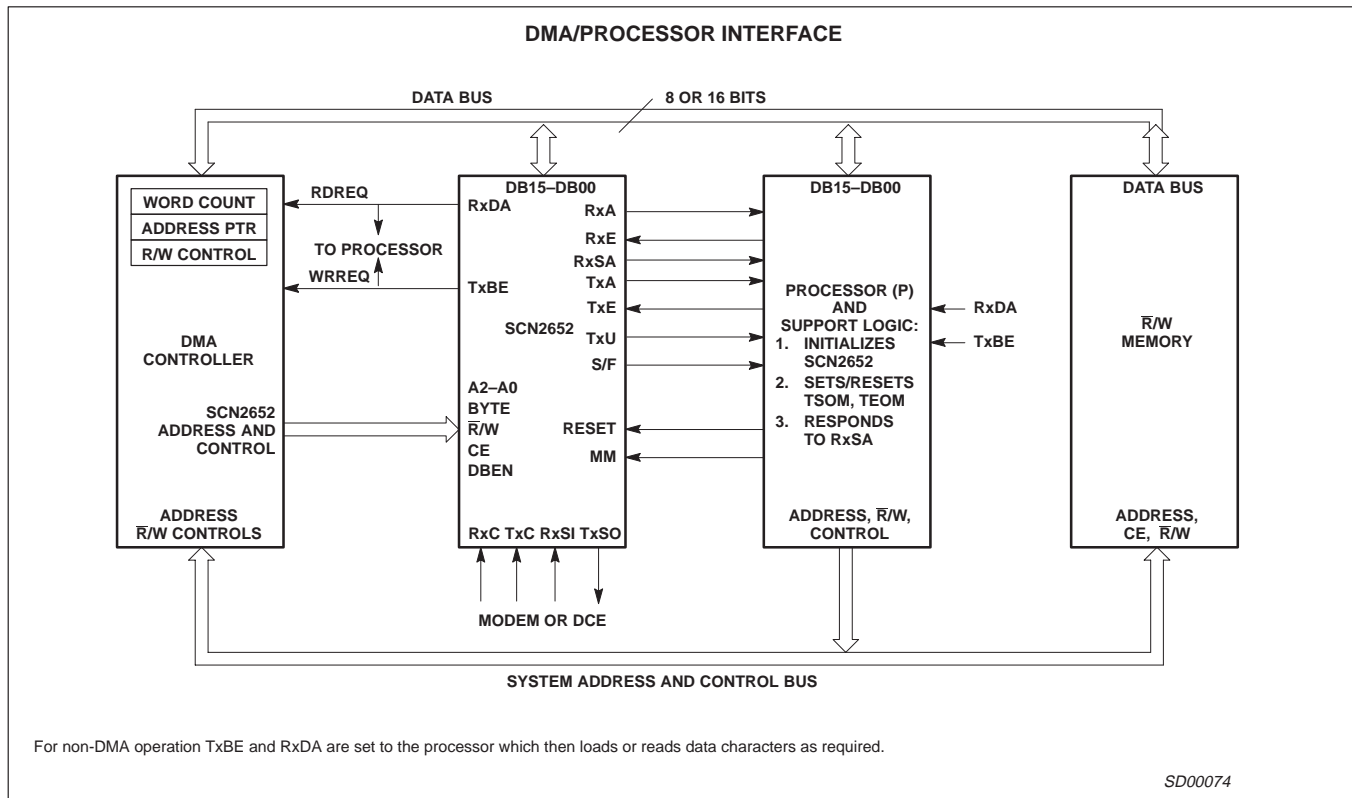

Figure 19. Typical Applications (cont.)

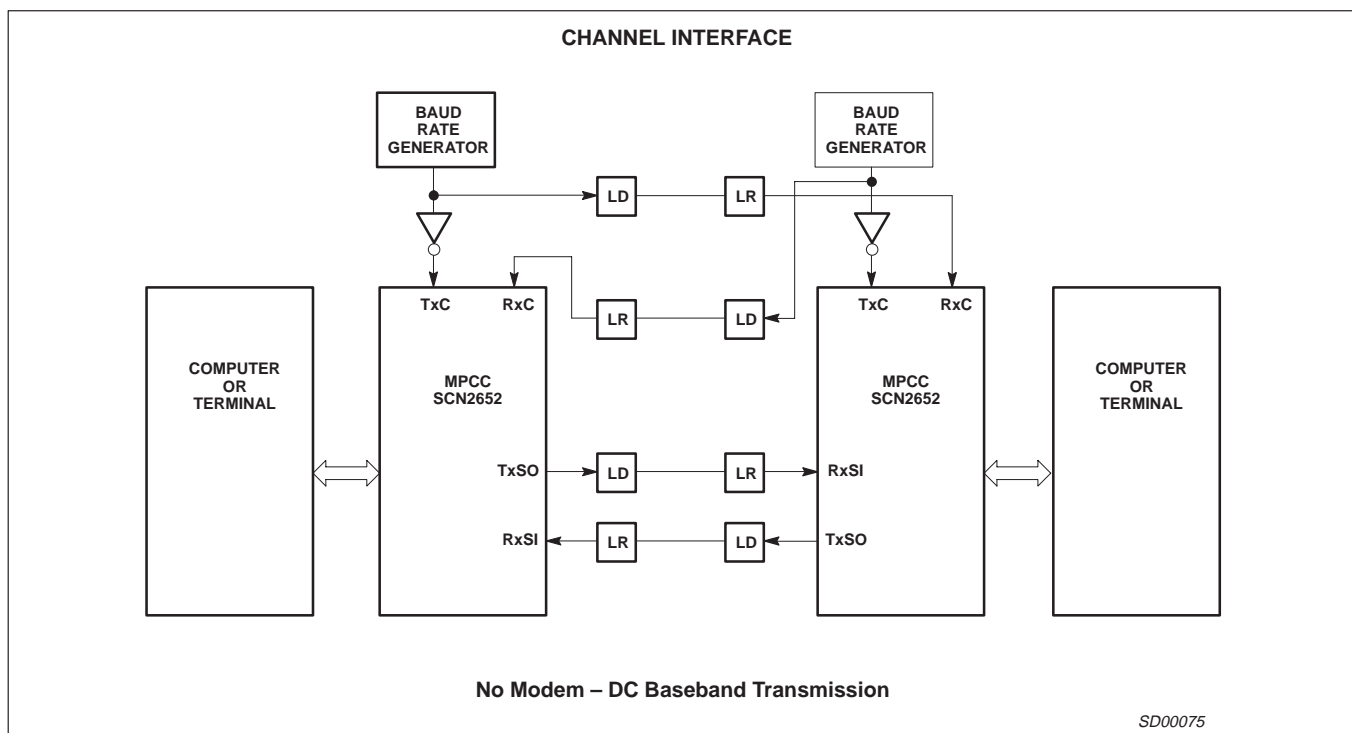

Figure 20. Typical Applications (cont.)

Multi-protocol communications controller (MPCC)

SCN2652/SCN68652

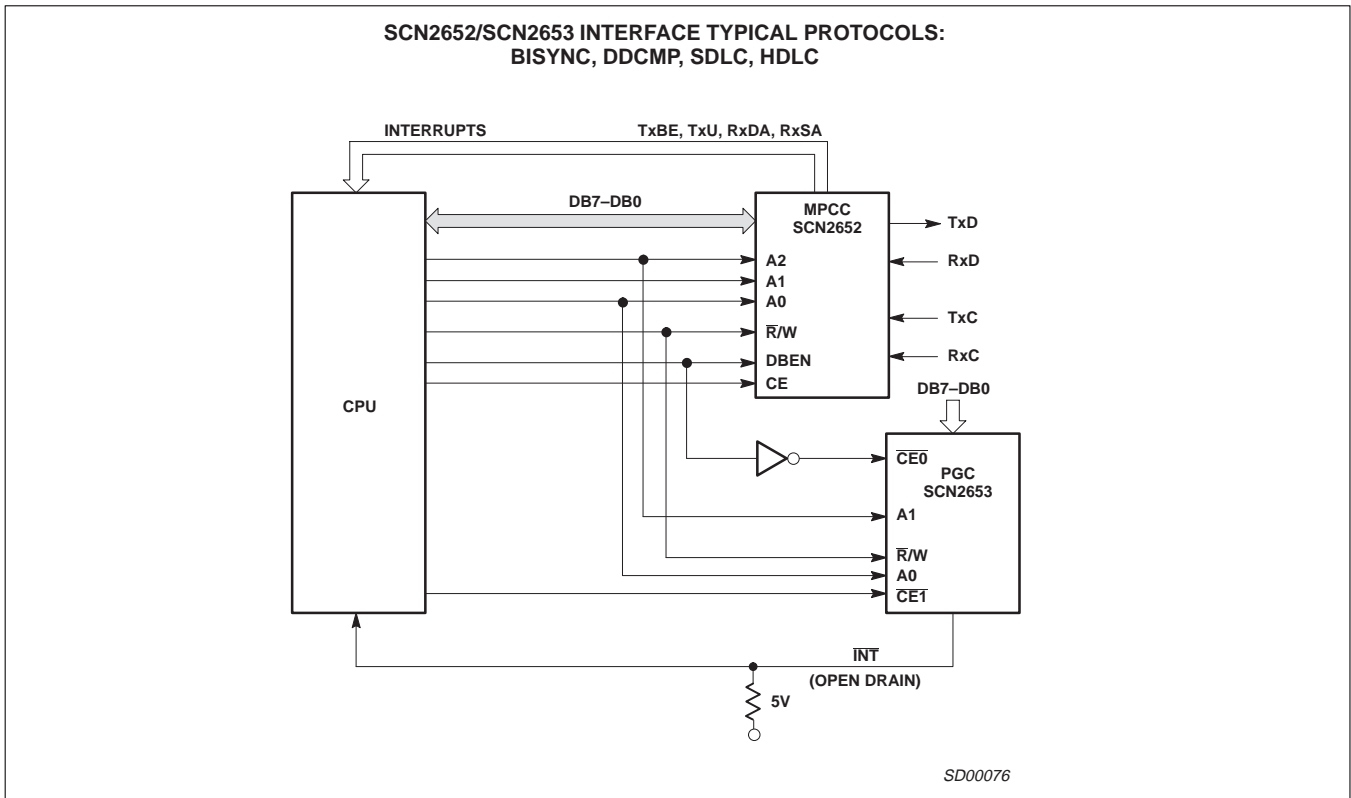

Figure 21. Typical Applications (cont.)

Multi-protocol communications controller (MPCC)

SCN2652/SCN68562

0590B 40-PIN (600 mils wide) CERAMIC DUAL IN-LINE (F) PACKAGE (WITH WINDOW (FA) PACKAGE)

NOTES:

1. Controlling dimension: Inches. Millimeters are shown in parentheses.
2. Dimension and tolerancing per ANSI Y14. 5M-1982.
3. "T", "D", and "E" are reference datums on the body and include allowance for glass overrun and meniscus on the seal line, and lid to base mismatch.
4. These dimensions measured with the leads constrained to be perpendicular to plane T.
5. Pin numbers start with Pin #1 and continue counterclockwise to Pin #40 when viewed from the top.
6. Denotes window location for EPROM products.

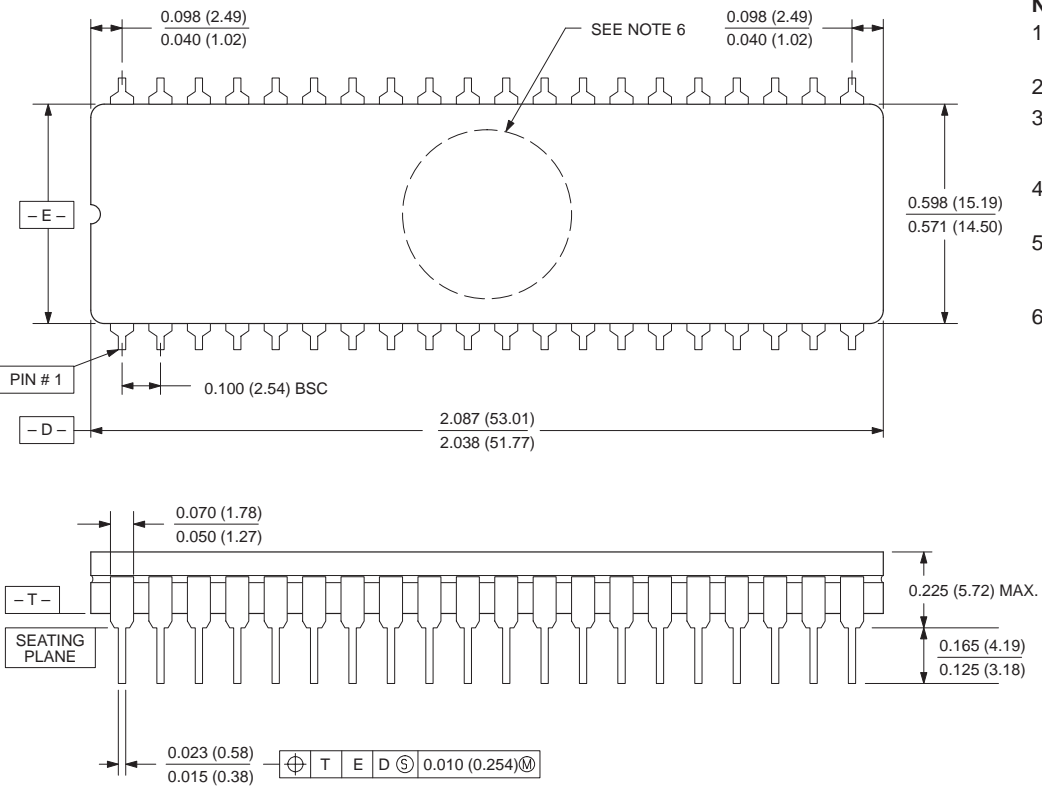
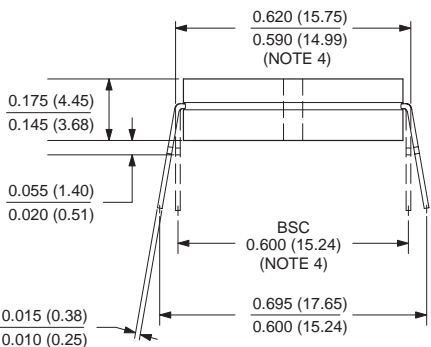

853-0590B 06688

Multi-protocol communications controller (MPCC)

SCN2652/SCN68562

DIP40: plastic dual in-line package; 40 leads (600 mil)

SOT129-1

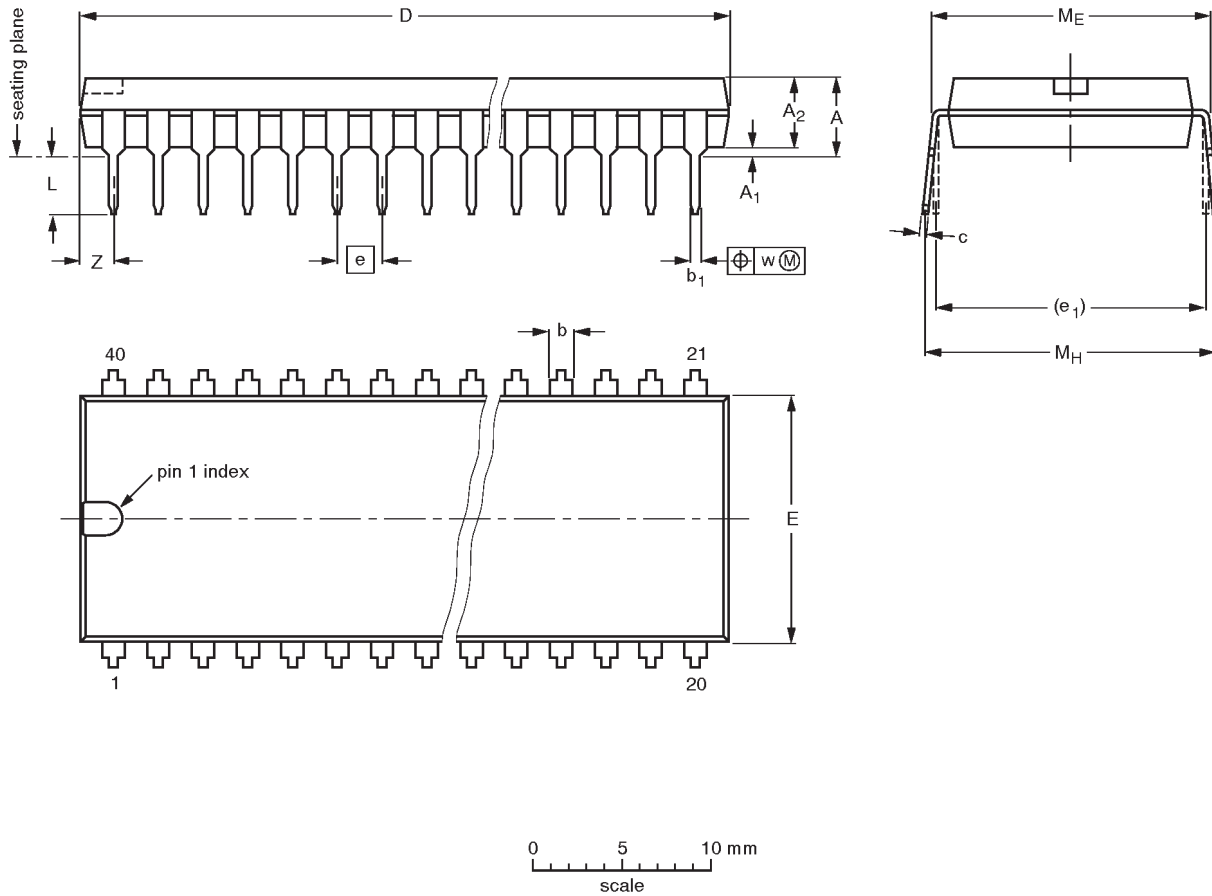

DIMENSIONS (inch dimensions are derived from the original mm dimensions)

UNIT	A max.	A ₁ min.	A ₂ max.	b	b ₁	c	D ⁽¹⁾	E ⁽¹⁾	e	e ₁	L	M _E	M _H	w	Z ⁽¹⁾ max.
mm	4.7	0.51	4.0	1.70 1.14	0.53 0.38	0.36 0.23	52.50 51.50	14.1 13.7	2.54	15.24	3.60 3.05	15.80 15.24	17.42 15.90	0.254	2.25
inches	0.19	0.020	0.16	0.067 0.045	0.021 0.015	0.014 0.009	2.067 2.028	0.56 0.54	0.10	0.60	0.14 0.12	0.62 0.60	0.69 0.63	0.01	0.089

Note

1. Plastic or metal protrusions of 0.25 mm maximum per side are not included.

OUTLINE VERSION	REFERENCES				EUROPEAN PROJECTION	ISSUE DATE
	IEC	JEDEC	EIAJ			
SOT129-1	051G08	MO-015AJ				92-11-17 95-01-14

Multi-protocol communications controller (MPCC)

SCN2652/SCN68562

PLCC44: plastic leaded chip carrier; 44 leads

SOT187-2

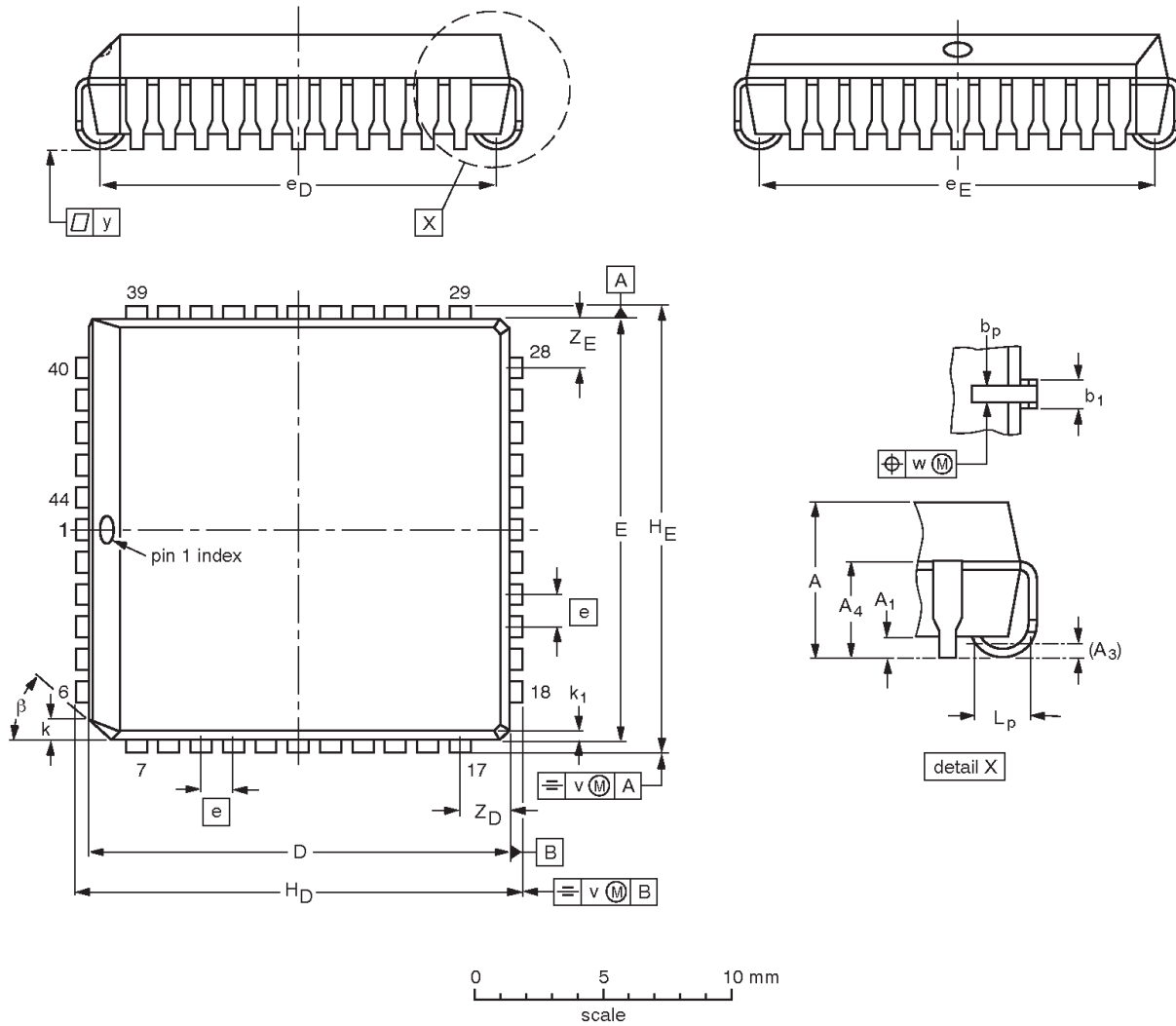

DIMENSIONS (millimetre dimensions are derived from the original inch dimensions)

UNIT	A	A ₁ min.	A ₃	A ₄ max.	b _p	b ₁	D ⁽¹⁾	E ⁽¹⁾	e	e _D	e _E	H _D	H _E	k	k ₁ max.	L _p	v	w	y	Z _D ⁽¹⁾ max.	Z _E ⁽¹⁾ max.	β
mm	4.57 4.19	0.51	0.25	3.05	0.53 0.33	0.81 0.66	16.66 16.51	16.66 16.51	1.27	16.00 14.99	16.00 14.99	17.65 17.40	17.65 17.40	1.22 1.07	0.51	1.44 1.02	0.18	0.18	0.10	2.16	2.16	45°
inches	0.180 0.165	0.020	0.01	0.12	0.021 0.013	0.032 0.026	0.656 0.650	0.656 0.650	0.05	0.630 0.590	0.630 0.590	0.695 0.685	0.695 0.685	0.048 0.042	0.020	0.057 0.040	0.007	0.007	0.004	0.085	0.085	

Note

1. Plastic or metal protrusions of 0.01 inches maximum per side are not included.

OUTLINE VERSION	REFERENCES				EUROPEAN PROJECTION	ISSUE DATE
	IEC	JEDEC	EIAJ			
SOT187-2	112E10	MO-047AC				95-02-25 97-12-16

Multi-protocol communications controller (MPCC)

SCN2652/SCN68562

NOTES

Multi-protocol communications controller (MPCC)

SCN2652/SCN68562

Data sheet status

Data sheet status	Product status	Definition [1]
Objective specification	Development	This data sheet contains the design target or goal specifications for product development. Specification may change in any manner without notice.
Preliminary specification	Qualification	This data sheet contains preliminary data, and supplementary data will be published at a later date. Philips Semiconductors reserves the right to make changes at any time without notice in order to improve design and supply the best possible product.
Product specification	Production	This data sheet contains final specifications. Philips Semiconductors reserves the right to make changes at any time without notice in order to improve design and supply the best possible product.

[1] Please consult the most recently issued datasheet before initiating or completing a design.

Definitions

Short-form specification — The data in a short-form specification is extracted from a full data sheet with the same type number and title. For detailed information see the relevant data sheet or data handbook.

Limiting values definition — Limiting values given are in accordance with the Absolute Maximum Rating System (IEC 134). Stress above one or more of the limiting values may cause permanent damage to the device. These are stress ratings only and operation of the device at these or at any other conditions above those given in the Characteristics sections of the specification is not implied. Exposure to limiting values for extended periods may affect device reliability.

Application information — Applications that are described herein for any of these products are for illustrative purposes only. Philips Semiconductors make no representation or warranty that such applications will be suitable for the specified use without further testing or modification.

Disclaimers

Life support — These products are not designed for use in life support appliances, devices or systems where malfunction of these products can reasonably be expected to result in personal injury. Philips Semiconductors customers using or selling these products for use in such applications do so at their own risk and agree to fully indemnify Philips Semiconductors for any damages resulting from such application.

Right to make changes — Philips Semiconductors reserves the right to make changes, without notice, in the products, including circuits, standard cells, and/or software, described or contained herein in order to improve design and/or performance. Philips Semiconductors assumes no responsibility or liability for the use of any of these products, conveys no license or title under any patent, copyright, or mask work right to these products, and makes no representations or warranties that these products are free from patent, copyright, or mask work right infringement, unless otherwise specified.

Philips Semiconductors
811 East Arques Avenue
P.O. Box 3409
Sunnyvale, California 94088-3409
Telephone 800-234-7381

© Copyright Philips Electronics North America Corporation 1998
All rights reserved. Printed in U.S.A.

print code

Date of release: 08-98

Document order number:

Let's make things better.