



WTS701

WINBOND SINGLE-CHIP TEXT-TO-SPEECH PROCESSOR

The information contained in this datasheet may be subject to change without notice. It is the responsibility of the customer to check the Winbond USA website (www.winbond-usa.com) periodically for the latest version of this document, and any Errata Sheets that may be generated between datasheet revisions.



1. GENERAL DESCRIPTION

The WTS701 is a high quality, fully integrated, single-chip Text-to-Speech solution that is ideal for use in applications such as automotive appliances, GPS/navigation systems, cellular phones and other portable products or accessories. The WTS701 product accepts ASCII (Unicode and Big5 for Mandarin) input via a SPI port and converts it to spoken audio via an analog output or digital CODEC output.

The WTS701 integrates a text processor, smoothing filter and multi-level memory storage array on a single-chip. Text-to-speech conversion is achieved by processing the incoming text into a phonetic representation that is then mapped to a corpus of naturally spoken word parts. The synthesis algorithm attempts to use the largest possible word unit in the appropriate context to maximize natural sounding speech quality. The speech units are stored uncompressed in a multi-level, non-volatile analog storage array to provide the highest sound quality to density trade-off. This unique, single-chip solution is made possible through Winbond's patented multilevel storage technology. Voice and audio signals are stored directly into solid-state memory in their natural, uncompressed form, providing superior quality voice reproduction.

The chip can be programmed through the SPI port, allowing downloading of different languages and speaker databases when made available by Winbond.



2. FEATURES

- **Fully Integrated Solution**
 - Single-chip compact text-to-speech translation
 - No algorithm development required
 - Selectable digital and analog audio output
 - Simple SPI interface
 - Reprogrammable solution enables loading different voice or language

- **Text-To-Speech Algorithm Characteristics**
 - High quality speech synthesis using speech element concatenation
 - Winbond's standard 100-year speech retention
 - Audio stored as uncompressed analog waveform – industry's highest quality and most natural sounding

- **Easy to Use and Control**
 - Real time conversion for streaming text
 - General text preprocessing and normalization
 - User customization for special characters such as SMS icons and chat emoticons
 - User customization for application specific abbreviations

- **Language Support**
 - Support U.S. English and Mandarin (Beijing dialect)
 - Other languages in development or in planning

- **Device Management**
 - Accepts ASCII, Unicode or Big5 streaming text
 - 256-byte text buffer
 - Playback of Phonetic Alphabet
 - Variable speed playback
 - Control of pitch change
 - Supports Power Down mode.
 - Supports Pause and Resume, Stop and Finish text conversion commands
 - Embedded characters support to control speed, volume, case sensitivity, and silent behavior

- **Peripheral Control**
 - 16-bit linear PCM slave interface output support
 - SPI serial port for control commands and status report to system's host controller
 - Hardware handshake control signals
 - Analog audio output with 8Ω speaker driver, digital volume control and line level o/p
 - Analog audio input (AUXIN) for driving external audio to the speaker

- **Low Power Consumption**
 - +2.7 to +3.3V (V_{CC}) Supply Voltage
 - Operating Current:
 - $I_{CC\ Convert} = 35\text{ mA (typical)}$
 - Standby Current:
 - $I_{SB} < 1\mu\text{A (typical)}$

- **Device Characteristics**
 - Available in 56-lead TSOP package
 - Industrial temperature range (-40C to +85C)
 - 3V/5V logic tolerance

3. BLOCK DIAGRAM

3.1. WTS701 BLOCK DIAGRAM

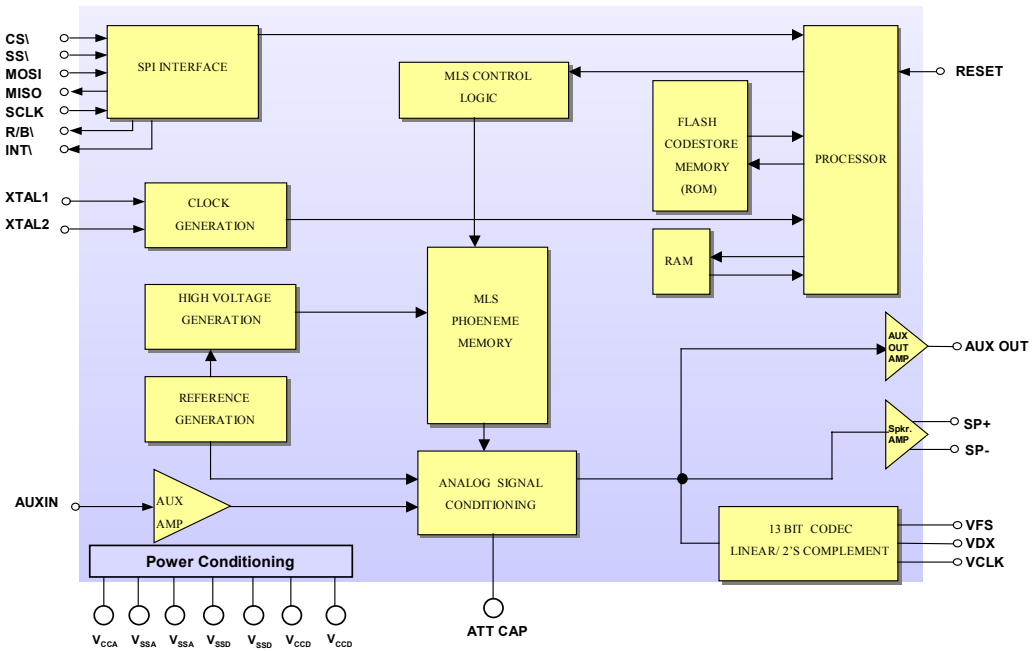

Figure 1. WTS701 Block Diagram.

3.2. WTS701 TYPICAL APPLICATIONS

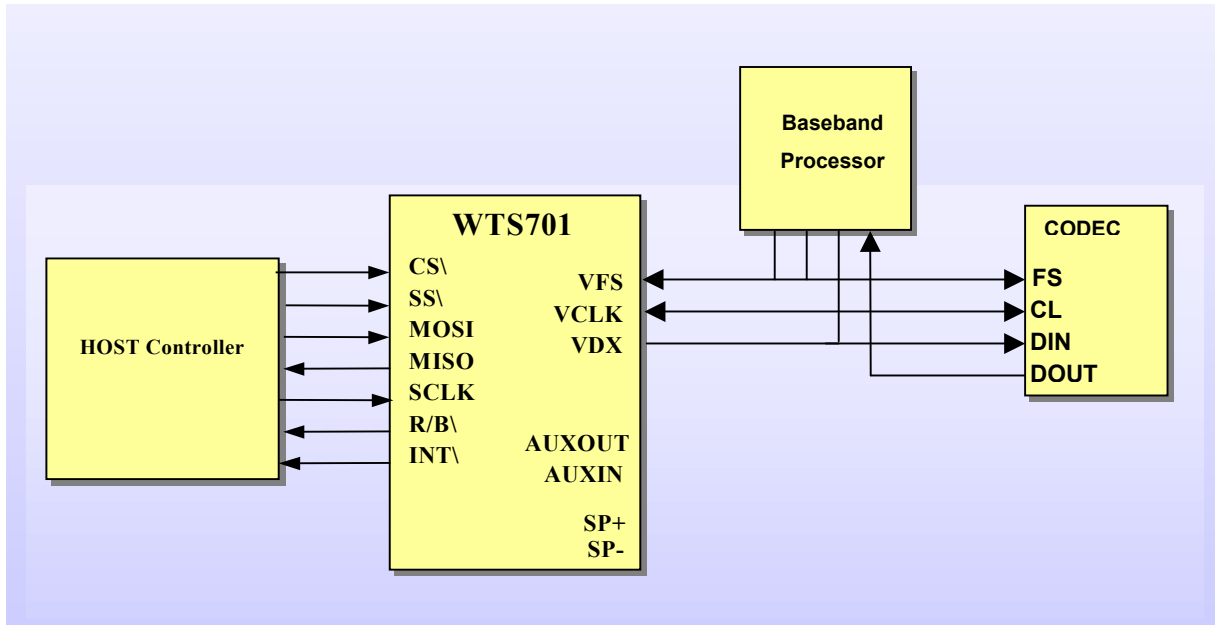

Figure 2. WTS701 Configuration for Digital (CODEC) Environment.

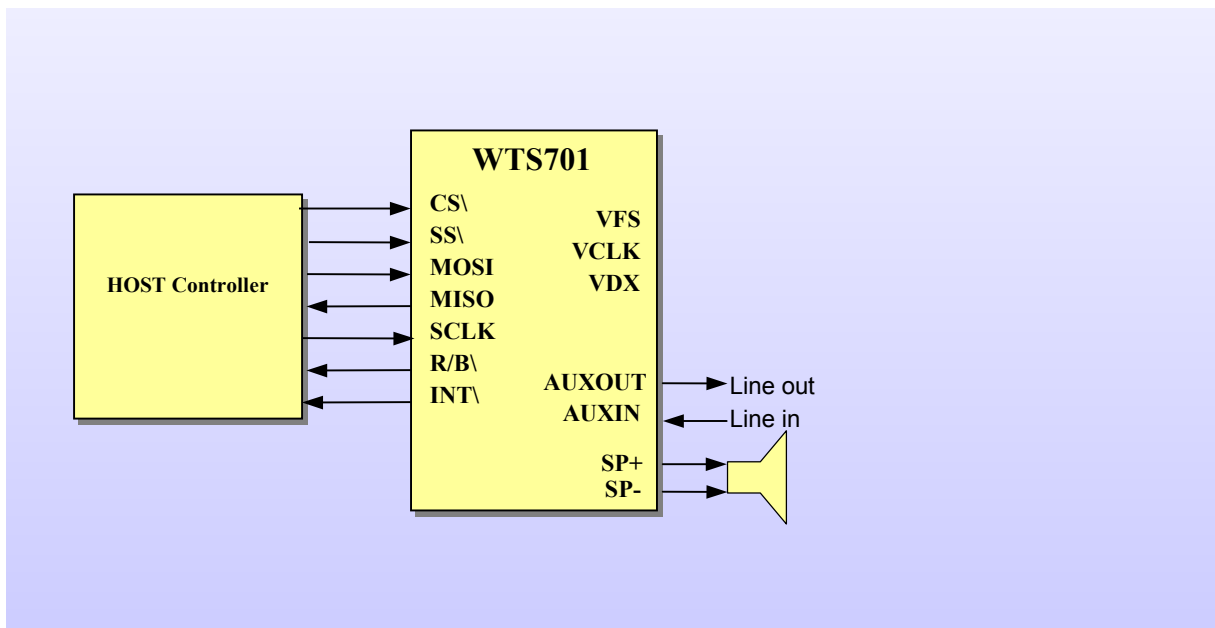

Figure 3. WTS701 Configuration for Analog Environment



4. TABLE OF CONTENTS

1. GENERAL DESCRIPTION.....	2
2. FEATURES	3
3. BLOCK DIAGRAM	4
3.1. WTS701 Block Diagram	4
3.2. WTS701 Typical Applications.....	5
4. TABLE OF CONTENTS	6
5. PIN CONFIGURATION	8
6. PIN DESCRIPTION	9
7. FUNCTIONAL DESCRIPTION.....	11
7.1 Text-To-Speech Mechanism	12
7.1.1 Text Normalization	12
7.1.2 Words-to-Phoneme conversion	12
7.1.3 Phoneme Mapping.....	12
7.2 Physical Interface	13
7.2.1 Clocking Requirements.....	13
7.2.2 Power Down Mode.....	14
7.2.3 Power and Grounding	14
7.2.4 SPI Interface	15
7.2.5 Flow Control Interface.....	16
7.2.6 The CODEC Interface.....	16
7.2.7 The Analog Interface.....	17
7.2.8 Resetting	18
7.3 Communication Protocol.....	19
7.3.1 Command Classes.....	20
7.3.2 Status Register.....	21
7.3.3 Interrupt Handler	22
7.3.4 BCNT – Byte Count Register.....	23
7.3.5 Command Acceptance.....	23
7.3.6 Data Acceptance.....	23
7.4 Commands Overview	23
7.4.1 Command Description	26
7.4.2 Illegal Commands	37
7.4.3 Configuration Registers	37
7.4.4 System Operation	41
7.4.5 Initialization and Configuration.....	43



7.4.6 Converting Text.....	43
7.5 SPI Interface	46
7.5.1 SPI Transactions.....	46
7.6 CODEC Interface.....	49
7.7 Control Characters.....	52
7.7.1 Phonetic Alphabet Playback	52
7.7.2 Speed Change	54
7.7.3 Volume Change	55
7.7.4 Case Sensitivity.....	55
7.7.5. Pause Control	55
7.8 Customizing Abbreviations	56
7.8.1 Abbreviation Data Format	56
7.8.2 Abbreviation Table Format.....	57
7.8.3 Command Execution.....	57
7.9 Device Programming	58
7.10 Text-To-Speech Processor Commmands – Quick Reference Table.....	59
7.10.1 Text Input Format.....	64
7.10.2. Buffer length limit	65
7.10.3. Undefined characters.....	65
8. TIMING WAVEFORMS	66
8.1 SPI Timing Diagram.....	66
8.2 CODEC Timing Diagrams	68
9. ABSOLUTE MAXIMUM RATINGS.....	70
10. ELECTRICAL CHARACTERISTICS	71
11. TYPICAL APPLICATION CIRCUIT	74
12. PACKAGE DRAWING AND DIMENSIONS	75
13. ORDERING INFORMATION.....	76
14. VERSION HISTORY	77

5. PIN CONFIGURATION

The following sections detail the pins of the WTS701 processor.

[Table 1](#) shows all the pins and the signals that use them in different configurations. It also shows the type and direction of each signal. [Figure 4](#) shows the physical pin out of the 56-pin TSOP package.

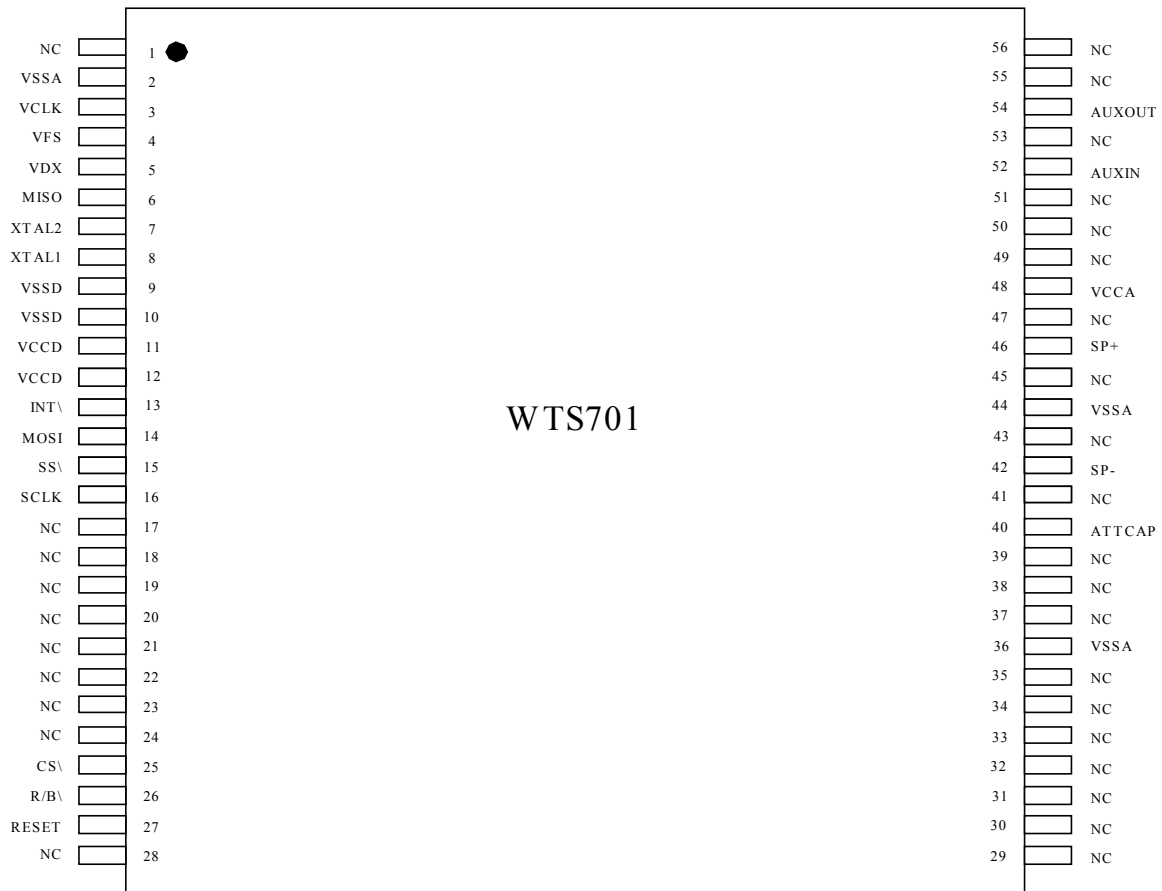

Figure 4. 56-pin TSOP Package Connection Diagram.

6. PIN DESCRIPTION

Table 1. WTS701 Pin Signal Assignment.

PIN NO.	SYMBOL	I/O	FUNCTION
2,36,44	VSSA	G	Analog Ground pins.
3	VCLK	I	CODEC master clock
4	VFS	I	CODEC frame synchronization signal
5	VDX	O	CODEC data output. This pin puts data out in the linear PCM unsigned or 2's complement format. It is tri-stated until the user requests a CONVERT operation.
6	MISO	O	SPI Master In, Slave Out pin. Serial data line used to communicate with SPI master. Pin is tri-state when $\overline{SS}=1$.
7	XTAL2	O	CRYSTAL 2: This is the crystal oscillator output. It is the inversion of XTAL1.
8	XTAL1	I	CRYSTAL 1: This is the crystal oscillator input. This pin may be driven by an external clock. The clock to the WTS701 processor is configured by a clock configuration register, which is set by the host processor during the initialization phase.
9,10	VSSD	G	Digital Ground pin.
11,12	VCCD	P	Positive Digital Voltage Supply pin. These pins carry noise generated by internal clocks in the chip. They must be independently bypassed to Digital Ground to ensure correct device operation and not connected together.
13	\overline{INT}	O	Interrupt Output; an open drain output that indicates that the device wishes an interrupt service. The device can request an interrupt when it finishes an operation or needs more data to process. Under what conditions the device generates an interrupt can be configured through the user configuration registers. This pin remains LOW until a Read Interrupt command is executed.
14	MOSI	I	SPI Master Out, Slave In . Serial data input from Master and Open Drain
15	\overline{SS}	I	SPI Slave Select input. This is an active LOW input used to select the device to respond to an SPI transaction.
16	SCLK	I	SPI Serial clock input.
25	\overline{CS}	I	Chip Select (active LOW) Pin must be LOW to access WTS701 device.
26	R/ \overline{B}	O	Ready/busy signal; This pin defaults HIGH indicating the device is ready for data transfer. The pin is driven LOW to handshake a pause in SPI data transfer and Open Drain.

PIN NO.	SYMBOL	I/O	FUNCTION
27	RESET	I	Global reset signal.
40	ATTCAP	I/O	AutoMute Capacitor Pin. Should have a 4.7uF capacitor to V_{SSA} .
42	SP-	O	Differential Negative Speaker Driver Output.
46	SP+	O	Differential Positive Speaker Driver Output.
48	VCCA	P	Positive Analog Voltage Supply pin. This pin supplies the LOW level audio sections of the device. It should be carefully bypassed to Analog Ground to ensure correct device operation.
52	AUXIN	I	Analog input pin. This pin should be capacitively coupled. See page 73 for example.
54	AUXOUT	O	Analog Output for single ended output from the device.
1,17- 24,28- 35,37- 39,41,43, 45,47,49- 51,53,55- 56	NC		Not Connected – must be floating.

Note: TYPE I:Input, O:Output, I/O bi-directional, P:Power, G:Ground

7. FUNCTIONAL DESCRIPTION

As a real System-On-Chip solution, the WTS701 performs the overall control functions for host controller and text-to-speech processing.

The WTS701 system architecture consists of the following functions:

- Serial interface to monitor the SPI port and interpret commands and data
- Text normalization module to pre-process incoming text into pronounceable words
- Words to phoneme translator, which converts incoming text to phoneme codes
- Phoneme mapping module that maps incoming phonemes to words, sub-words, syllables or phonemes present in the MLS memory
- Volume and speed adjustments
- Digital and analog output blocks for off-chip usage

The WTS701 system performs text-to-speech synthesis based on concatenative samples. The units for concatenation can vary from whole words down to phoneme units. The convention is that the larger the sub-word unit used for synthesis the higher the quality of the speech output. A corpus of pre-recorded words is stored in Winbond's patented multilevel storage (MLS) memory and a mapping of the various sub-word parts is held in a lookup table. The speech creation is achieved by concatenation of these speech elements to produce words. The system process flow is shown in Figure 5.

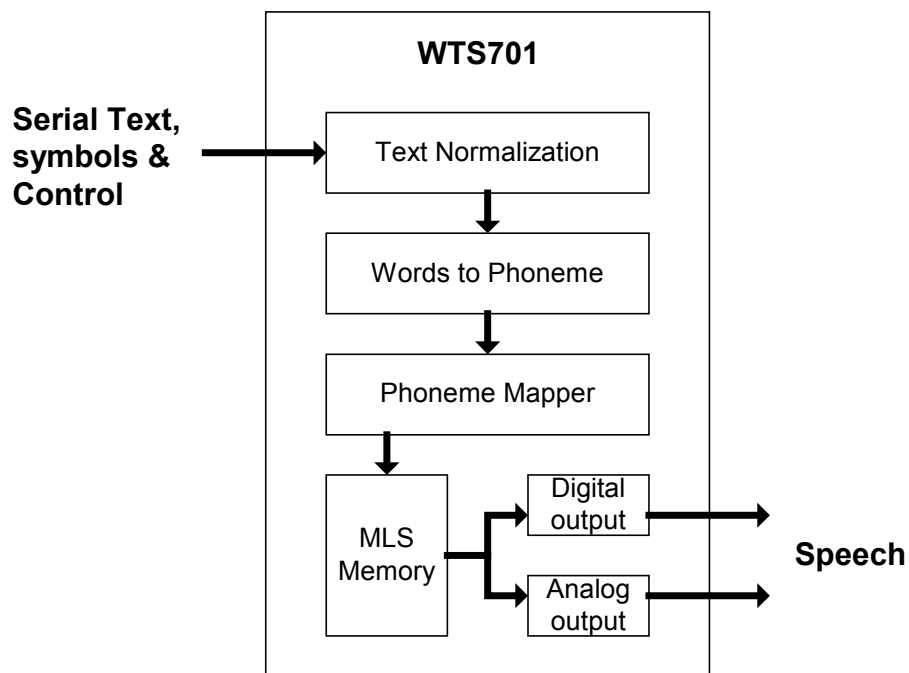

Figure 5. WTS701 System Process Flow.



7.1 TEXT-TO-SPEECH MECHANISM

The text to speech component of the system consists of three principal blocks:

- Text normalization
- Word to phoneme conversion
- Phoneme mapping

7.1.1 Text Normalization

Text normalization involves the translation of incoming text into pronounceable words. It includes such functions as expanding abbreviations and translating numeric strings to spoken words. It involves a certain amount of context processing to determine correct spoken form.

In addition, the WTS701 looks into the abbreviation list stored in the device's internal memory and converts acronyms, abbreviations or special characters (such as Instant Messaging icons or emoticons) into the appropriate text representation.

The default abbreviation list supported by the WTS701 is a general one that cannot be modified by the user to match the domain that the text is being loaded from. But the default list can be overridden by the user abbreviation list. This enables a flexibility of adding abbreviation specifically for the text either by the developer or even the end user to best customize the product for its preferences. Instant Messaging or Short Messages Service (SMS) unique characters are supported through this functionality as well, defining the icon, ASCII/Unicode/Big5 text, and its replacement. The default abbreviation list supported is described in the [specific language release letter](#).

7.1.2 Words-to-Phoneme conversion

Once the data stream has been translated to pronounceable words, the system next determines how to pronounce them. This function is obviously highly language dependent. For a language such as English it is impossible to break this task down to a set of definitive rules. The task is achieved by a combination of rule based processing together with exception processing.

7.1.3 Phoneme Mapping

This algorithm maps phoneme strings into the MLS phonetic inventory. This task falls into two portions. First, the word must be split into sub-word portions. This splitting must be done at appropriate phonetic boundaries to achieve high quality concatenation. Once a sub-word unit is determined, the inventory is searched to determine if a match is present. A matching weight is assigned to each match depending on how closely the phonetic context matches. Each sub-word has a left and right side context to match as well as the phoneme string itself. If no suitable match is found in the inventory, then the sub-word is further split in a tree like manner until a match is found. The splitting tree is processed from left to right and each time a successful match occurs the address and duration of the match in the corpus is placed in a queue of phonetic parts to be played out the audio interface.

7.2 PHYSICAL INTERFACE

The following sections describe the physical pin properties and the timing associated with the physical interface to the device. Note that all input pins are 3V and 5V tolerant, except for the \overline{CS} signal which is only 3V tolerant.

7.2.1 Clocking Requirements

The WTS701 processor can receive its clock from either an external clock source or a crystal oscillator. The XTAL1 and XTAL2 pins provide the crystal interface to the device. The clock to the WTS701 processor is configured by a clock configuration register, which must be set by the host processor during the initialization phase. [Figure 6](#) below shows how to connect the WTS701 to a crystal oscillator. An external clock can be connected to the WTS701 providing the clock source for the system, as shown in [Figure 6](#).

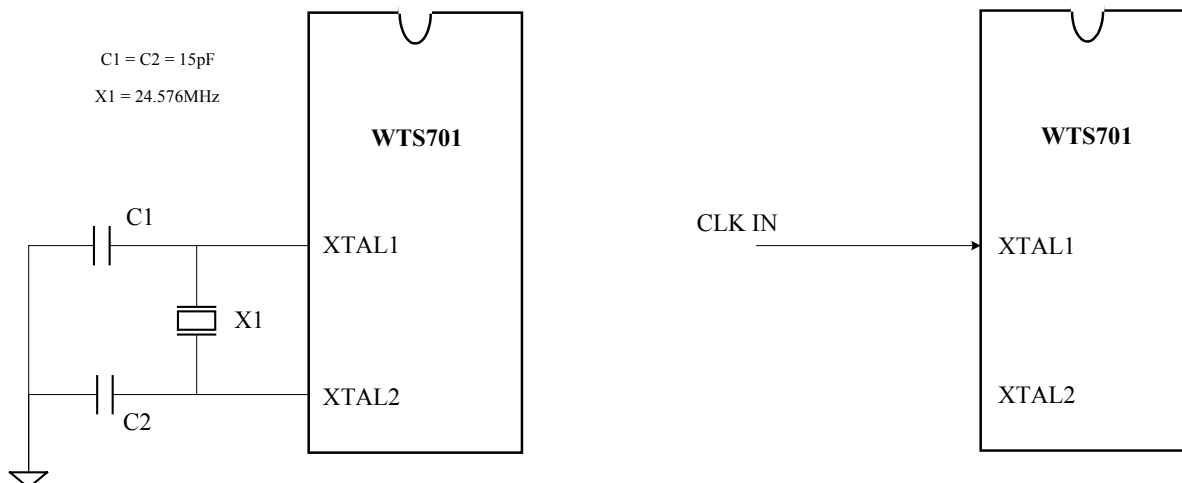

Figure 6. Clock Generation.

Suggested Crystal Specification:

$F = 24.576\text{ MHz}$ Fundamental Mode Operation

$C_L = 16\text{ pF}$

ESR = 60 Ω maximum



7.2.2 Power Down Mode

Upon application of power, the WTS701 will enter the RESET state and then be in a POWER DOWN state. In the POWER DOWN mode, only Class0 SPI commands are valid. (See subsection [7.3.1](#)). The Power Down status of the device can be determined with a RDST (Read Status) command, specified by the RDY bit in STATUS BYTE 0.

Issuing the PWDN (Power Down) command to the WTS701 processor will return the processor to the POWER DOWN mode. In POWER DOWN mode the external crystal oscillator is shut off and the processor is deactivated. POWER DOWN mode is exited by issuing a PWUP (Power Up) command to the WTS701. The PWUP command should be preceded by a SCLC (Set Clock) command to ensure correct clock configuration.

7.2.3 Power and Grounding

The WTS701 can operate over 2.7V to 3.3V supply voltage range. The power supply and ground pins (V_{CCA} , V_{CCD} , V_{SSA} , V_{SSD}) should be carefully bypassed as close to the chip as possible to ensure high quality audio. In addition, ATTCAP pin should have a 4.7 μ F capacitor connected to ground. This pin must NOT be left floating. The pins that are marked as NC (Not Connected), MUST be left floating.

V_{CCA} , V_{CCD} (Voltage Inputs)

To minimize noise, the analog and digital circuits in the WTS701 device use separate power busses. These +3.0 V busses lead to separate pins. For optimal noise immunity, tie the V_{CCD} pins together as close as possible and decouple both supplies as near to the package as possible.

V_{SSA} , V_{SSD} (Ground Inputs)

The WTS701 series utilizes separate analog and digital ground busses. The analog ground (V_{SSA}) pins should be tied together as close to the package as possible and connected through a low-impedance path to power supply ground. The digital ground (V_{SSD}) pin should be connected through a separate low-impedance path to power supply ground. These ground paths should be large enough to ensure that the impedance between the V_{SSA} pins and the V_{SSD} pin is less than 3Ω . The backside of the die is connected to V_{SSD} through the substrate resistance.

NC (Not Connect)

These pins MUST not be connected to the board at any time. Connection of these pins to any signal, ground or V_{CC} may result in incorrect device behavior or cause damage to the device.



7.2.4 SPI Interface

Communications with the WTS701 is conducted over the SPI serial communications port. The device responds to a command when the Chip Select signal (\overline{CS}) is LOW and addressed by an active LOW signal on the \overline{SS} (Slave Select) pin. Under this condition, it accepts data on the MOSI input, which is clocked in on rising edges of the serial clock (SCLK) signal. Concurrently, valid data from the WTS701 device to the bus master is available on MISO for the HIGH period of SCLK. The protocol implemented on the WTS701 defines that the first two bytes of data sent in an SPI transaction is a command word. A transaction is defined as the SPI transfers conducted while \overline{SS} is LOW, the transaction ends when \overline{SS} returns HIGH. A list of available commands can be found in subsection [7.10](#) (Text-To-Speech Processor Commands Quick Reference Table). The data flow over the SPI interface is MSB first, both in and out of the WTS701.

All Input pins are 3V and 5V tolerant, except for the \overline{CS} signal which is only 3V tolerant.

The following is a description of the WTS701 SPI interface signals:

SCLK (Serial Clock)

The Serial Clock line is a digital input. It is driven by the SPI master and controls the timing of the data exchanged over the SPI data lines, MOSI and MISO. The maximum frequency for this pin is 5 MHz.

\overline{SS} (Slave Select)

The Slave Select line is an active LOW digital input. It is driven by the SPI master and acts as a chip select line. The device only responds to SPI transactions when this line is selected (LOW) and then raised HIGH after SPI communication ends.

\overline{CS} (Chip Select)

The Chip Select line is an active LOW digital input. It can be driven by the host controller to enable SPI transactions to the device. Normally this pin is tied LOW unless more than one device is to share the same \overline{SS} signal.

MOSI (Master Out, Slave In)

The MOSI line is a digital input. MOSI is driven by the SPI master. It provides data transfer, MSB first, from the master to the slave. (See page 64)

MISO (Master In, Slave Out)

The MISO line is an open drain digital output. When \overline{SS} is HIGH, this pin is tri-state. When \overline{SS} is LOW, MISO is driven by the device. It provides serial data transfer, MSB first, from the slave to the master.



7.2.5 Flow Control Interface

In addition to the SPI interface, the WTS701 has two control lines to facilitate data transfer and host communications. The $\overline{\text{INT}}$ (interrupt) pin is used by the WTS701 to request an interrupt service from the host controller. The interrupt types that the device generates are controlled by the communications control register command (SCOM). The $\overline{\text{R/B}}$ (ready/busy) pin is used to control the flow of data across the SPI bus. When this signal is HIGH, the device can accept more data. When it is LOW, SPI transactions must be paused or terminated.

$\overline{\text{INT}}$ (Interrupt)

$\overline{\text{INT}}$ is an open drain output pin. The WTS701 interrupt pin goes LOW and stays LOW when an interrupt event has occurred, as defined by the SCOM command. The interrupt is cleared when a RINT (read interrupt) command is executed. The status register defines what type of interrupt has occurred.

$\overline{\text{R/B}}$ (Ready/Busy Signal)

The $\overline{\text{R/B}}$ line is an output open drain pin used to control data transfer rate across the SPI port. The line is used as a handshake signal to the SPI Master to indicate when the device is ready for more data. When HIGH, the master is free to send more data. When LOW, the device is busy and cannot accept more data.

7.2.6 The CODEC Interface

The WTS701 provides an on chip interface for digital environment systems, supporting slave CODEC interface mode. The WTS701 CODEC interface is controlled by an external source hence the WTS701 only transmits data. Thus, it is effectively an analog-to-digital converter. Each analog sample is converted to 10 bit digital word. This digital word is transmitted with the MSB first. Since the host expects either 13 or 16 bit data in the short frame format, either three or six zeros are appended as the LSB. It interfaces to the baseband CODEC via the VCLK, VFS and VDX lines. Refer to [Figure 2](#), for more information about the connection between the WTS701 and a CODEC.

All Input pins are 3V and 5V tolerant.

The following is a description of the WTS701 CODEC interface signals:

VCLK (CODEC Clock Line)

The CODEC clock line supplies the sampling clock to the internal CODEC. This is a digital input and expects a 512kHz—2.048MHz clock.



VFS (CODEC Synchronization Line)

The CODEC synchronization line supplies a frame synchronization signal to the internal CODEC. This is a digital input. After receipt of a synchronization pulse, the CODEC will output data on the VDX line. The VFS line expects an 8kHz sample rate and supports both short frame and long frame synchronization signal.

VDX (CODEC Data Transmit Line)

The CODEC data transmit line is a digital output that places digital audio data onto the CODEC bus. The line is in a tri-state condition until the device is due to transmit data. The data output from the VDX line is selected by the SCOD Command. When WTS701 places data on the VDX line, it is required that the VFS line should be in tri-state condition when another device is connected to the CODEC as well.

7.2.7 The Analog Interface

The WTS701 provides an on-chip analog interface for audio output via an 8Ω speaker driver or an output buffer capable of driving a $5k\Omega$ load. Additionally, an analog input (AUXIN) allows an audio signal to be fed through the WTS701 chip to either output device. The command SAUD configures the analog path. A digitally controlled attenuator provides volume control via the SVOL command.

The following is a description of the analog pins:

AUXIN (Analog Input)

The AUXIN is an additional audio input to the WTS701. This input has a nominal 694 mV p-p level at its minimum gain setting (0 dB) (See [Table 2](#)). Additional gain is available in 3 dB steps (controlled by the SAUD Command) up to 9 dB. The use and equivalent circuit of the input amplifier is shown in [Figure 7](#). (Must be AC coupled)

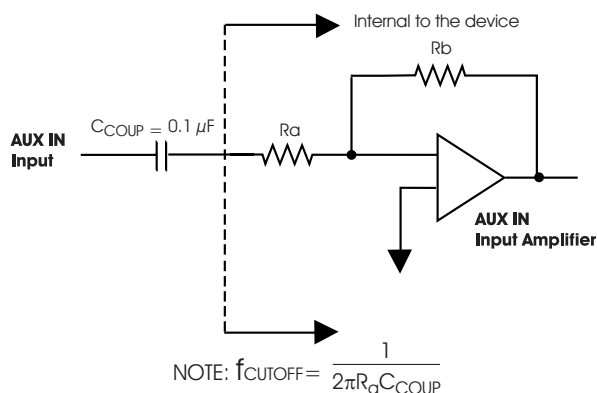

Figure 7. AUXIN Input Amplifier.

Table 2. AUXIN Gain Settings.

OTLP Input V_{P-P}^1	AUD Register		Gain ²	Gain ² (dB)	Resistor Ratio (R_b/R_a)	Speaker Out V_{P-P}^3
	AIG1	AIG0				
0.694	0	0	1.00	0	40.1 / 40.1	1.388
0.491	0	1	1.41	3	47.0 / 33.2	1.388
0.347	1	0	2.00	6	53.5 / 26.7	1.388
0.245	1	1	2.82	9	59.2 / 21	1.388

¹OTLP Input is the reference Transmission Level Point that is used for testing. This level is typically 3 dB below clipping.

²From AUXIN to AUXOUT. ³Measured differentially at SP+/SP-.

AUXOUT (Analog Output)

The AUXOUT is an audio output pin used to provide an analog output of the synthesized speech from the WTS701. It drives a minimum load of 5 k Ω up to a maximum of 1 V p-p. The AC signal is superimposed on approximately 1.2 VDC bias and must be capacitively coupled to the load. This output stage may be powered down by clearing the AOPU bit via the SAUD command.

SP +, SP- (Speaker +/-)

This is the speaker differential output circuit. It is designed to drive an 8 Ω speaker connected across the speaker pins up to a maximum of 23.5 mW power. This stage has selectable gains of 1.32 and 1.6, which can be chosen through the SPG bit via the SAUD command. These pins are biased to approximately 1.2 VDC and, if used single-ended, must be capacitively coupled to their load. Do **NOT** ground the unused pin. This output stage may be powered down by clearing the SPPU bit via the SAUD command.

ATTCAP (AutoMute Attenuator Capacitor)

This pin provides a capacitor connection for setting the AutoMute. It should have a 4.7 μ F capacitor connected to ground and it cannot be left floating. The AutoMute circuit reduces the amount of noise present in the output during quiet pauses.

7.2.8 Resetting

The chip has an internal power-on reset circuit that ensures correct initialization upon application of power. The reset pin signal must be held HIGH for 0.5 μ s to achieve a reset (see [Figure 8](#)) and to put the WTS701 in the RESET state. Once the WTS701 completes the reset, it will enter the POWER DOWN mode. Before issuing active commands, a clock configuration and device power up command must be issued in the POWER DOWN mode.

Issuing a Reset command (RST) resets the WTS701 processor to the initial POWER DOWN state. Applying the reset pin, while the chip is active, allows the host processor to reset the WTS701 to its default values and the IDLE state.

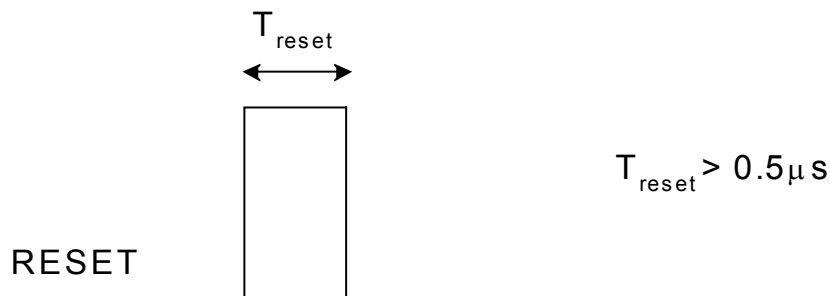

Figure 8. Reset Condition Timing.

7.3 COMMUNICATION PROTOCOL

The WTS701 is controlled by a series of SPI transactions to send commands to the device. The general format of an SPI transaction is shown in [Figure 9](#). A transaction is always started by sending a command word. The command word consists of a command byte followed by a command data byte. At the same time, the status register is shifted out on the MISO line. What follows depends on what command is sent. The general case is that following the command word, up to n -bytes of data can be sent to the device and n -bytes can be read from the device. An SPI transaction is finished when \overline{SS} is returned to the HIGH condition.

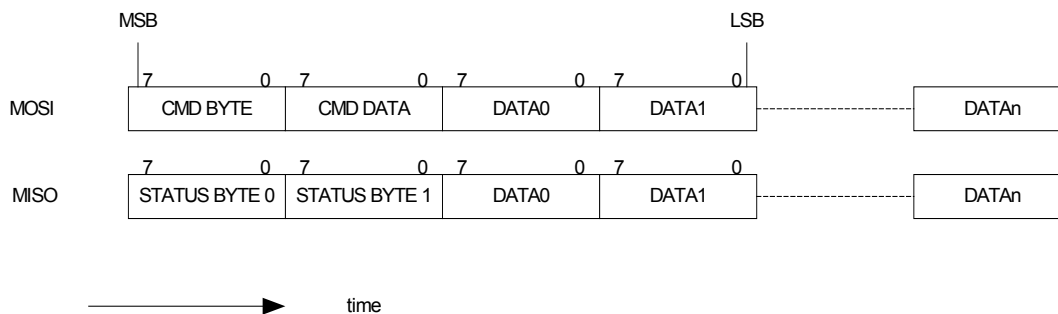

Figure 9. SPI Transaction Format.



7.3.1 Command Classes

The SPI transactions to the WTS701 fall into four classes. The four classes represent variations in how the command, and any associated data, is handled. The class of a command is defined by the two most significant bits of the command byte. A summary of the command classes is given below

Class 0 Commands

These are commands that are executed irrespective of the state of the WTS701. That is, the command will execute even if the device is busy or powered down. These commands are executed internally by a hardware command interpreter. All commands not of class 0 require that the WTS701 be in a powered up state. Example of class 0 command is the Read Status (RDST) command.

Class 1 Commands

Class 1 commands require interpretation by the internal firmware of the WTS701. Class 1 commands consist only of a command byte and command data byte. Any further data sent in a transaction is ignored. Class 1 commands are most often used for setting a configuration register in the device or sending commands that have no data such as the conversion pause (PAUS) command.

Class 2 Commands

Class 2 commands have associated data. After the command word, any data bytes following are loaded into an internal FIFO buffer for processing. If this FIFO becomes full, the $\overline{R/B}$ signal is asserted (LOW) indicating that the host must pause data transfer. An alternative to monitoring the $\overline{R/B}$ line, the $\overline{R/B}$ bit of the status register can be monitored instead (see subsection [7.3.2](#)) or via the RDST command. The $\overline{R/B}$ bit cannot be used for intra-byte flow control, e.g. if a string of characters is sent, only every other byte is checked.

Class 3 Commands

Class 3 commands have data to return to the host. The $\overline{R/B}$ line will go to busy immediately following the command word indicating that the WTS701 is fetching the requested data. Data is put into the BCNT0 and BCNT1 (see subsection [7.3.4](#)) registers and is read out in the two subsequent bytes after $\overline{R/B}$ is released. If more than two bytes are returned from the command, $\overline{R/B}$ will again be asserted until data is ready to read. The primary Class 3 commands are to read the contents of internal configuration registers such as RREG command.



7.3.2 Status Register

The WTS701 has a sixteen-bit status register whose value is returned to the host controller during the command word. For class 2 commands, the status register is repeatedly returned every two bytes. This status register provides the host with information regarding the current status of the chip. The host can decide on required actions with this information. The Status Register is echoed back by all commands.

Table 3. Status Bytes.

	Bit 7	Bit 6	Bit 5	Bit 4	Bit 3	Bit 2	Bit 1	Bit 0
Status Byte 0	<i>ICNT</i>	<i>IBUF</i>	<i>ICNV</i>	<i>COD</i>	<i>BFUL</i>	<i>BEMP</i>	<i>CNVT</i>	<i>RDY</i>
Status Byte 1	<i>R/B</i>	<i>Reserved</i>	<i>Reserved</i>	<i>Reserved</i>	<i>Reserved</i>	<i>IABB</i>	<i>Reserved</i>	<i>ICMD</i>

The contents of the status bytes are described in [Table 4](#).

Table 4. Status Bit Description.

Byte	Bit Name	Bit #	
Status Byte 0	RDY	0	Ready to accept commands. After the device has been powered up, this bit is set after the Power Up latency delay.
	CNVT	1	Converting. This bit is set anytime while the conversion process is running. If this bit is clear when a convert command is sent, the count in the Count register is set to 0.
	BEMP	2	The text input buffer is empty. This bit is set anytime the input buffer is empty.
	BFUL	3	The text input buffer is full. This bit is cleared after 128 bytes become available in the input buffer.
	COD	4	CODEC is enabled. This is set when the CODEC has been enabled by the SCOD command.
	ICNV	5	Conversion finished interrupt has occurred. To stop CODEC transmission or Power Down the analog outputs an IDLE command should be sent. This bit is cleared by RINT command.
	IBUF	6	The input text buffer been filled above the defined threshold and then gone below the defined threshold. The buffer threshold level is set by the SCOM command. If set by the SCOM command, the $\overline{\text{INT}}$ pin will also go LOW. This bit is cleared by RINT command.
ICNT	7	Count interrupt has occurred. This interrupt is generated every time a word has been spoken if activated by the SCOM command. This bit is cleared by RINT command.	
Status Byte 1*	ICMD	0	Command was ignored. Anytime ICMD is set, the transaction must revert to a single word command and the command must be resent. Any data sent will be ignored.
	IABB	2	Abbreviation interrupt has occurred, abbreviation add or abbreviation delete has been completed. Now the ENTER_RRSM command can be sent.
	$\overline{\text{R/B}}$	7	Current state of the $\overline{\text{R/B}}$ pin. If this bit is 0, any data sent will be ignored.

*5 bits are reserved.

7.3.3 Interrupt Handler

If an interrupt has occurred, no further interrupts will be registered until the first interrupt has been cleared. Only one interrupt can be active at any time.

The RINT command will read and clear pending interrupts while the RDST command will read interrupts without clearing them.

Make sure that all interrupts that are not being used are masked by clearing the corresponding bits in the COM register.



7.3.4 BCNT -- Byte Count Register

The byte count register (BCNT) is a tool for the host to keep track of where in a conversion the WTS701 is. When a new conversion is started, the byte count register is reset to zero. As each word (as defined by white-space separated characters) is spoken, the byte count register is updated to point to the first character of the next word to be spoken. In this way, the host can position a new conversion if the user wishes to repeat or skip text. The BCNT register is sent with BCNT1 (MSB) first and BCNT0 (LSB) second.

7.3.5 Command Acceptance

The WTS701 processes commands and data as they are sent to the device. Under certain conditions the device will not be ready to accept a new command or data. If the device has not finished processing the previous command, the ICMD bit of the status register will be set. If this bit is set, it implies that device is not in a position to accept the command being sent and that it will be ignored. The host should monitor this bit when a command is sent and, if it is detected, the SPI transaction should be terminated at the end of the command word. The host can then resend the command until the command is accepted.

7.3.6 Data Acceptance

The WTS701 has an eight byte FIFO to buffer data from the SPI port to the internal processor. During a conversion, data is read from this FIFO into an internal RAM data buffer. If SPI transmission is too fast for the WTS701 to keep up with, the $\overline{R/B}$ line will be asserted (LOW) to pause data transfer. Alternatively, the STATUS register can be monitored for the state of the $\overline{R/B}$ signal.

7.4 COMMANDS OVERVIEW

Control of the WTS701 is implemented through a 16-bit command word. The command word is always the first word to follow the falling edge on the \overline{SS} signal. The command word consists of the command byte followed by the command data byte. Many commands do not require a command data byte, although one must be sent. For commands that have no data, the command data byte is a 'don't care'.

Commands fall into five categories. Commands that control an operational synthesis function of the text-to-speech processing, commands that modify internal configuration registers, commands that change system state, commands that read internal status registers, and customization commands.



Status Commands

Table 5. Status Opcodes.

The WTS701 has three read-only registers accessed by the opcodes, which are shown to the right.

- The Read Status Register returns the device's operational status and the numbers of bytes that have been converted.
- The Read Interrupt Register returns the same status data and clears any of the interrupt status bits that are set.
- The Version Register returns the hardware and firmware version of the chip.

Opcode	Mnemonic	Function
0x04	RDST	Read Status Register
0x06	RINT	Read Interrupt Register
0x12	RVER	Device Version

System Commands

Table 6. System Opcodes.

The WTS701 responds to various system commands that change the state of the system, namely:

- The Power Up command wakes up the device from POWER DOWN mode.
- The Power Down command requests that the device enter the POWER DOWN mode.
- The Reset command resets the device (see subsection [7.4.4](#)).
- The Idle command puts WTS701 processor in IDLE mode

Opcode	Mnemonic	Function
0x02	PWUP	Power Up
0x40	PWDN	Power Down
0x10	RST	Reset
0x57	IDLE	Go Idle



Synthesis Commands

The synthesis commands affect the text-to-speech synthesis. They are detailed in the table to the right. The basic commands are:

- Start a conversion
- Pause the conversion
- Resume the conversion
- Stop the conversion
- Finish conversion at the end of the current word.
- Finish the conversion at the end of the buffer
- Volume up/down
- Speed up/down the text-to-speech conversion

Table 7. Synthesis Opcodes.

Opcode	Mnemonic	Function
0x81	CONV	Start Converting
0x49	PAUS	Pause Conversion
0x4A	RES	Resume Conversion
0x4B	ST	Stop Conversion
0x4D	FINW	Finish Word
0x4C	FIN	Finish Buffer
0x53	VLUP	Volume Up
0x54	VLDN	Volume Down
0x55	SPUP	Speed Up Conversion
0x56	SPDN	Slow Down Conversion

Configuration Commands

The WTS701 has several configuration registers. The commands are:

- The COM configuration register governs the behavior of how the chip uses the \overline{INT} and $\overline{R/B}$ hardware lines to communicate with the host
- The CODEC register configures the mode of the digital audio output
- The AUDIO register sets parameters of the analog audio path
- The VOLUME register sets the volume level of output
- The SPEED register sets the speed level of output speech
- The CLC register sets the master clock frequency of the device
- The SPTC command sets speech pitch

Table 8. Configuration Opcodes.

Opcode	Mnemonic	Function
0xC0	RREG	Read Configuration register
0x4E	SCOM	COM Configuration register
0x4F	SCOD	CODEC Configuration register
0x50	SAUD	AUDIO Configuration register
0x51	SVOL	VOL Configuration register
0x52	SSPD	SPEED Configuration register
0x14	SCLC	CLC (Clock) Configuration register
0x77	SPTC	Set Speech Pitch



Customization Commands

Table 9. Customization Opcodes.

The WTS701 has the ability for the user to customize the way in which it responds to certain text strings. This is done by way of an abbreviation table. The customization opcodes allow the user to interrogate and modify the abbreviation table.

Opcode	Mnemonic	Function
0xC8	ABBR_NUM	Get number of abbrev. entries
0xC9	ABBR_RD	Read abbreviation table
0xC7	ABBR_MEM	Get number of free bytes.
0xAF	ABBR_ADD	Add abbrev. entry
0x83	ABBR_DEL	Delete abbrev. entry
0x0C	ENTER_RRSM	Swap memory

7.4.1 Command Description

The following section list all the standard commands that can be executed on the WTS701.

PWDN Go to POWER DOWN Mode

This command puts the WTS701 processor in power-down mode. This is a single word command therefore no data is required for this command. The Power Down command places the WTS701 device into its lowest power consumption mode. In POWER DOWN mode, the device will only respond to a Power Up command (PWUP) and Read Status (RDST) command. As soon as Power Down sequence has ended, the RDY flag in the status word is cleared.

PWDN	Class	1	Type	I
Byte Sequence:	Host controller		0x40	0x00
	WTS701		Status Byte 0	Status Byte 1
Description:	Put the WTS701 processor in power-down mode.			

PWUP Power Up

This command wakes up the WTS701 processor to IDLE state. The result of this command is that the WTS701 starts the power up sequence, which leads to bringing up internal supplies, resetting the processor, all configuration registers are initialized to their default values and entering IDLE state. As soon as power up sequence has ended, the RDY flag in the status word is asserted. The SCLC command must be sent BEFORE PWUP.



PWUP	Class	0	Type	I
Byte Sequence:	Host controller	0x02		0x00
	WTS701	Status Byte 0	Status Byte 1	
Description:	Wake up the WTS701 processor to IDLE state.			

CONV Convert

The convert command starts the text to speech conversion process. The convert command is followed by ASCII text data. The device has a buffer of 256 bytes. When this buffer is full, the chip pulls the $\overline{R/B}$ line LOW and sets the BFUL bit in the status word indicating that the WTS701 buffer manager is in the buffer full condition. The WTS701 remains in the buffer full condition until the input buffer has been emptied of half the buffer space (128 bytes). When the buffer is full, the Host may do one of three things:

1. The Host may end the command at that point, then poll the BFUL bit of the SPI status register until it is clear, and then send new CONV commands with the additional ASCII text data.
2. The Host may also continue the command (keep \overline{SS} LOW) and wait for the $\overline{R/B}$ pin to go HIGH. As each word is processed by the WTS701, space will become free in the buffer and the $\overline{R/B}$ pin will go HIGH until it is full again.
3. The device may also be configured such that it will generate an interrupt to the host when the buffer threshold (set by RCOM command) has been crossed. (See [Tables 3](#) and [4](#)) This allows the host to fill the buffer then wait for the Interrupt to send the additional data.

During conversion, the Convert Count Register is updated as each word has been spoken. This register is cleared to zero at power up, and at the beginning of a new conversion process after one has been terminated.

A convert command is terminated in several ways:

- Send a finish command (FIN) indicating that the host has finished sending data. In this case, the device finishes converting the text buffer, then stops and enters a wait state.
- The conversion process will also stop when the EOT (^D, ASCII 0x1A, UNICODE/Big5 0x00 0x1A) character is part of the input text. When the device detects the EOT character, it will continue the conversion process until the buffer is emptied and the final word spoken. Then it will stop and enter the wait state.
- The finish word command (FINW) will cause the WTS701 device to finish the word currently being spoken, then flush the buffers and enter the wait state.



- The stop command (ST) will cause the WTS701 to immediately stop converting, flush the buffer and enter the wait state.

Once the wait state has been entered the device will clear the convert (CONV) bit from the status register and, if enabled, generate an ICVT interrupt. At this stage the CODEC and analog path are still active. To release the CODEC bus, or Power Down the analog path, an IDLE command should be sent to the device. If a convert command is terminated using any of the methods described in this section, another convert command cannot be sent until the previous conversion is completed. The CNVT bit must be polled to determine that conversion is completed before a new conversion can be started.

CONV	Class	2	Type	III		
Byte Sequence:	Host controller		0x81	0x00	DATA0	... DATAn
	WTS701		Status Byte 0	Status Byte 1	Status Byte 0	... Status Byte n%2
Description:	Start or continue a conversion process. Data sent is text data for conversion.					

PAUS PAUSE

This command causes a pause of the conversion process. There is no data associated with this command. The pause condition is terminated by the RES (Resume) command

PAUS	Class	1	Type	I		
Byte Sequence:	Host controller		0x49	0x00		
	WTS701		Status Byte 0	Status Byte 1		
Description:	This command pauses the conversion process.					

RES RESUME

This command causes the conversion to resume if it was paused. There is no data associated with this command

RES	Class	1	Type	I		
Byte Sequence:	Host controller		0x4A	0x00		
	WTS701		Status Byte 0	Status Byte 1		
Description:	This command resumes conversion after pause.					



ST STOP

This command immediately stops conversion without finishing buffer, and clears the buffer.

ST	Class	1	Type	I
Byte Sequence:	Host controller		0x4B	0x00
	WTS701		Status Byte 0	Status Byte 1
Description:	Stop conversion.			

FINW FINISH WORD

This command directs the WTS701 to finish text conversion at the end of the current word.

FINW	Class	1	Type	I
Byte Sequence:	Host controller		0x4D	0x00
	WTS701		Status Byte 0	Status Byte 1
Description:	This indicates that conversion is to end with the processing of the current word.			

FIN FINISH

This command indicates that no further conversion data is to follow and to stop conversion after processing the current buffer contents.

FIN	Class	1	Type	I
Byte Sequence:	Host controller		0x4C	0x00
	WTS701		Status Byte 0	Status Byte 1
Description:	Finish conversion after processing the current buffer.			



IDLE IDLE

This command is executed after the receipt of an end-of-conversion interrupt (ICNV) has occurred. The IDLE command will deactivate all audio outputs and bring the device to the IDLE state.

IDLE	Class	1	Type	I	
Byte Sequence:	Host controller		0x57		0x00
	WTS701		Status Byte 0		Status Byte 1
Description:	Put WTS701 in IDLE state.				

RDST READ STATUS

The Read Status command reads the status word of the device. If two dummy data bytes are also sent, the contents of the byte count register are also returned. Refer to subsections [7.3.2](#) and [7.3.4](#) for more information regarding the STATUS register and BCNT register.

RDST	Class	0	Type	II		
Byte Sequence:	Host controller		0x04		0x00	0x00
	WTS701		Status Byte 0		Status Byte 1	BCNT 1
Description:	Read Status word of the device.					

RVER READ VERSION

The Read version command reads the WTS701 version information. The software version information is only valid when the device is powered up.

RVER	Class	0	Type	II		
Byte Sequence:	Host controller		0x12		0x00	0x00
	WTS701		Status Byte 0		Status Byte 1	HW VER
Description:	Read WTS701 Software and Hardware versions.					

**RINT READ INTERRUPT**

The Read Interrupt command reads the status word of the device, it also clears the status interrupt request flags at the end of the transaction. As a result of this command, all interrupt bits are cleared and $\overline{\text{INT}}$ pin is released. Refer to subsections [7.3.2](#) and [7.3.4](#) for more information regarding the STATUS register and BCNT register.

RINT	Class	0	Type	II		
Byte Sequence:	Host controller	0x06		0x00	0x00	0x00
	WTS701	Status Byte 0	Status Byte 1	BCNT1	BCNT0	
Description:	Read status word and clear the status interrupt bits.					

RREG READ CONFIGURATION REGISTER

The read configuration register command reads the configuration register specified in the command data byte. The code 0xNN is the register number and it is described in [Table 10](#) – Configuration Registers, subsection [7.4.2](#).

RREG	Class	3	Type	IV		
Byte Sequence:	Host controller	0xC0		0xNN	0x00	0x00
	WTS701	Status Byte 0	Status Byte 1	XX	REG	
Description:	Read configuration register 0xNN.					

Note: XX = don't care.

SCOM SET COM REGISTER

Set the COM (interrupt communication) configuration register to value 0xNN. Refer to subsection [7.4.3](#) describing all configuration registers and the COM register in particular.

The Default value of this register after Power-Up or Reset is 0x00. Refer to subsection [7.4.3](#) - Configuration Registers, which describes all register bits.

SCOM	Class	1	Type	I		
Byte Sequence:	Host controller	0x4E		0xNN		
	WTS701	Status Byte 0	Status Byte 1			
Description:	Set the COM (interrupt communication) configuration register to value 0xNN.					

**SCOD SET COD REGISTER**

Set the COD (CODEC control) configuration register to value 0xNN.

The Default value of this register after Power-Up or Reset is 0x01. Refer to subsection [7.4.3](#) - Configuration Registers, which describes all register bits.

SCOD	Class	1	Type	I
Byte Sequence:	Host controller		0x4F	0xNN
	WTS701		Status Byte 0	Status Byte 1
Description:	Set the COD (CODEC control) configuration register to value 0xNN.			

SAUD SET AUD REGISTER

Set the AUD (analog audio) configuration register to value 0xNN.

The Default value of this register after Power-Up or Reset is 0x43. Refer to subsection [7.4.3](#) - Configuration Registers, which describes all register bits.

SAUD	Class	1	Type	I
Byte Sequence:	Host controller		0x50	0xNN
	WTS701		Status Byte 0	Status Byte 1
Description:	Set the AUD (analog audio) configuration register to value 0xNN.			

SVOL SET VOL REGISTER

Set the VOL (volume) configuration register to value 0xNN.

The Default value of this register after Power-Up or Reset is 0x07. Refer to subsection [7.4.3](#) - Configuration Registers, which describes all register bits.

SVOL	Class	1	Type	I
Byte Sequence:	Host controller		0x51	0xNN
	WTS701		Status Byte 0	Status Byte 1
Description:	Set the VOL (volume) configuration register to value 0xNN.			

**SSPD SET SPD REGISTER**

Set the SPD (speech rate/speed) configuration register to value 0xNN.

The Default value of this register after Power-Up or Reset is 0x02. Refer to subsection [7.4.3](#) - Configuration Registers, which describe all register bits.

SSPD	Class	1	Type	I
Byte Sequence:	Host controller	0x52		0xNN
	WTS701	Status Byte 0	Status Byte 1	
Description:	Set the SPD (speech rate/speed) configuration register to value 0xNN.			

SCLC SET CLC REGISTER

Set the Clock configuration register (CLC) to value 0xNN.

The value of this register **must** be set before Power-Up or Reset command to 0x00. Refer to subsection [7.4.3](#) - Configuration Registers, which describes all register bits.

SCLC	Class	0	Type	I
Byte Sequence:	Host controller	0x14		0xNN
	WTS701	Status Byte 0	Status Byte 1	
Description:	Set the Clock configuration register (CLC) to value 0xNN.			

SPTC SET SPEECH PITCH

Set the speech pitch to value 0xNN. The valid pitch values are between 0x00 and 0x06 while the default pitch value is 0x05, and these values can be used to control the speech output pitch. The command can be executed only when the WTS701 is in IDLE state.

SPTC	Class	1	Type	I
Byte Sequence:	Host controller	0x77		0xNN
	WTS701	Status Byte 0	Status Byte 1	
Description:	Set the speech pitch parameter to value 0xNN.			

**VLUP VOLUME-UP COMMAND**

Increment the volume (VOL) register. Has no effect if already at maximum volume.

The Default value of this register after Power-Up or Reset is 0x07. Refer to subsection [7.4.3](#) - Configuration Registers, which describes all register bits.

VLUP	Class	1	Type	I
Byte Sequence:	Host controller		0x53	0x00
	WTS701		Status Byte 0	Status Byte 1
Description:	Increment the volume (VOL) register.			

VLDN VOLUME DOWN COMMAND

Decrement the volume (VOL) register. This has no effect if already at minimum volume. The Default value of this register after Power-Up or Reset is 0x07. Refer to subsection [7.4.3](#) - Configuration Registers, which describes all register bits.

VLDN	Class	1	Type	I
Byte Sequence:	Host controller		0x54	0x00
	WTS701		Status Byte 0	Status Byte 1
Description:	Decrement the volume (VOL) register.			

SPUP SPEED UP COMMAND

Increase speaking rate (SPD register). This has no effect if already at maximum speaking rate. The Default value of this register after Power-Up or Reset is 0x02. Refer to subsection [7.4.3](#) - Configuration Registers, which describes all register bits.

SPUP	Class	1	Type	I
Byte Sequence:	Host controller		0x55	0x00
	WTS701		Status Byte 0	Status Byte 1
Description:	Increase speaking rate (SPD register).			



SPDN SPEED DOWN COMMAND

Decrease speaking rate (SPD register). Has no effect if already at minimum speaking rate. The Default value of this register after Power-Up or Reset is 0x02. Refer to subsection [7.4.3](#) - Configuration Registers, which describes all register bits.

SPDN	Class	1	Type	I	
Byte Sequence:	Host controller		0x56		0x00
	WTS701		Status Byte 0		Status Byte 1
Description:	Decrease speaking rate (SPD register).				

RST RESET COMMAND

Sending this command has the same affect as a Power-On reset, the WTS701 enters the POWER DOWN state.

RST	Class	0	Type	I	
Byte Sequence:	Host controller		0x10		0x00
	WTS701		Status Byte 0		Status Byte 1
Description:	Reset the WTS701 device.				

ABBR_ADD ADD ABBREVIATION

Add an entry to the abbreviation table.

ABBR_ADD	Class	2	Type	III			
Byte Sequence:	Host controller		0xAF	0x00	DATA0	...	DATAn
	WTS701		Status Byte 0	Status Byte 1	Status Byte 0	...	Status Byte n%2
Description:	Add an entry to the abbreviation table..						



ABBR_MEM RETURN ABBREVIATION MEMORY

The ABBR_MEM command will return the number of bytes available in the abbreviation table in MEM_HI and MEM_LOW.

ABBR_MEM	Class	3	Type	IV		
Byte Sequence:	Host controller		0xC7	0x00	0x00	0x00
	WTS701		Status Byte 0	Status Byte 1	MEM_HI	MEM_LOW
Description:	Return the number of bytes available in the abbreviation table.					

ABBR_NUM RETURN NUMBER OF ABBREVIATION ENTRIES

The ABBR_NUM command will return the number of abbreviation entries in the abbreviation table in NUM_HI and NUM_LOW.

ABBR_NUM	Class	3	Type	IV		
Byte Sequence:	Host controller		0xC8	0x00	0x00	0x00
	WTS701		Status Byte 0	Status Byte 1	NUM_HI	NUM_LOW
Description:	Return the number of abbreviation entries in the abbreviation table.					

ABBR_RD READ ABBREVIATION TABLE

The ABBR_RD command will return the abbreviation table. This command must read 2048 bytes after receiving the Status register.

ABBR_RD	Class	3	Type	IV			
Byte Sequence:	Host controller		0xC9	0x00	0x00	0x00
	WTS701		Status Byte 0	Status Byte 1	ABBR0	ABBRn
Description:	Return the 2048 bytes of abbreviations.						

**ABBR_DEL DELETE ABBREVIATION ENTRY**

This command deletes abbreviation entry from abbreviation table.

ABBR_DEL	Class	2	Type	I			
Byte Sequence:	Host controller		0x83	0x00	DATA0	...	DATAn
	WTS701		Status Byte 0	Status Byte 1	Status Byte 0	...	Status Byte n%2
Description:	Delete an entry from the abbreviation table.						

ENTER_RRSM SWAP MEMORY

This command is used in programming mode, and causes the xdata and code store memory to swap spaces. Please refer to subsection [7.8](#) for more information about customizing abbreviations.

ENTER_RRSM	Class	0	Type	I			
Byte Sequence:	Host controller		0x0C		0x00		
	WTS701		Status Byte 0		Status Byte 1		
Description:	Swap memory between xdata and code store.						

7.4.2 Illegal Commands

All commands described in section 7.4.1 are the only legal commands that should be sent to the WTS701 device, unless stated otherwise. Other commands should not be sent to the device, as the device behavior cannot be predicted. Specific illegal commands are those in which the 2 Most Significant Bits of the Command Byte are zeros and are not defined in this document as commands allowed to be sent to the WTS701.

7.4.3 Configuration Registers

The configuration registers are accessed by sending the appropriate configuration command followed by a single byte of data to load the register. The definition of the contents of the various registers is given below. The default value for each of these registers after Power Up or Reset is also described in [Table 10](#).

Table 10. Configuration Registers.

Register	Reg. #	Default	MSB							LSB	
			Bit 7	Bit 6	Bit 5	Bit 4	Bit 3	Bit 2	Bit 1	Bit 0	
COM	0x4E	0x00	ICNT	IBUF	ICNV	X	X	X	BUF1	BUF0	
COD	0x4F	0x01	X	X	X	X	X	MD2	MD1	MD0	
AUD	0x50	0x43	AOPU	SPPU	SPG	FDTH	X	X	AIG1	AIG0	
VOL	0x51	0x07	X	X	X	X	X	VL2	VL1	VL0	
CLC	0x14	None	X	X	X	CLC4	CLC3	CLC2	CLC1	CLC0	
SPD	0x52	0x02	X	X	X	X	X	SPD2	SPD1	SPD0	

X = Reserved.

The bits of each register are described below:

COM Register

- ICNT** If set to a '1', the device will generate an interrupt when the Count register has been updated. This occurs after each word has been spoken.
- IBUF** If set to '1', the device will generate an interrupt when the buffer level crosses the threshold set by the BUF bits. (see [Table 3](#), Status bytes).
- ICNV** If set to '1', the device will generate an interrupt when the end of a conversion is reached.
- BUF1..0** If IBUF is set, BUF1..0 determines the buffer level at which the interrupt will be generated.
 - 00b – Input buffer empty.
 - 01b – Input buffer <10% full.
 - 10b – Input buffer <50% full.
 - 11b – Input buffer <75% full.



COD Register

- MD2** CODEC enable, possible modes are:
0b: CODEC disabled.
1b: CODEC enabled during conversion.
- MD1** CODEC precision, possible modes are:
0b: 13 bit linear PCM output
1b: 16 bit linear PCM output.
- MD0** CODEC output format, possible modes are:
0b: unsigned PCM output
1b: 2's complement PCM output.

AUD Register

- AOPU** 1b: Power up the analog output buffer.
- SPPU** 1b: Power up the analog speaker driver.
- SPG** Speaker Driver gain selection.
0b: 8 Ω Speaker. $A_v = 1.32$
1b: 100 Ω Speaker. $A_v = 1.6$
- FDTH** 1b: Enable feed-through path from AUXIN to AUXOUT.
- AIG1..0**
AUXIN gain setting
00b – 0dB
01b – 3dB
10b – 6dB
11b – 9dB



VOL Register

VL2..0

Volume level of output.

000 – 0dB

001 – -4dB

010 – -8dB

011 – -12dB

100 – -16dB

101 – -20dB

110 – -24dB

111 – -28dB

Each step gives a 4dB attenuation of output.

CLC Register

CLC4..0

Configure the device for different master clock frequencies.

0x00	24.576 MHz
0x10	16.384 MHz
0x08	32.768 MHz

(The only clock frequency currently recommended for operation is 24.576MHz.)

SPD Register

SPD2..0

Configure the speech speed register. 0x04 is the fastest speed and 0x00 is the slowest.

7.4.4 System Operation

The WTS701 is a single chip solution for text-to-speech synthesis. The Text-to-Speech operation is accomplished by a process of screening the incoming text to normalize common abbreviations and numbers into a spoken form. The normalized text is then analyzed for phonetic interpretation and this phonetic translation is mapped into samples to be played out of the analog storage array. This output signal is then smoothed by a low-pass filter and is available as an analog signal, or can be passed through the CODEC for digital audio output.

The WTS701 processor state machine

The WTS701 functions as a state machine and changes states either in response to a command sent by the host controller, after execution of command is completed, or as a result of an internal event.

The WTS701 states are described below in reference to [Figure 10](#).

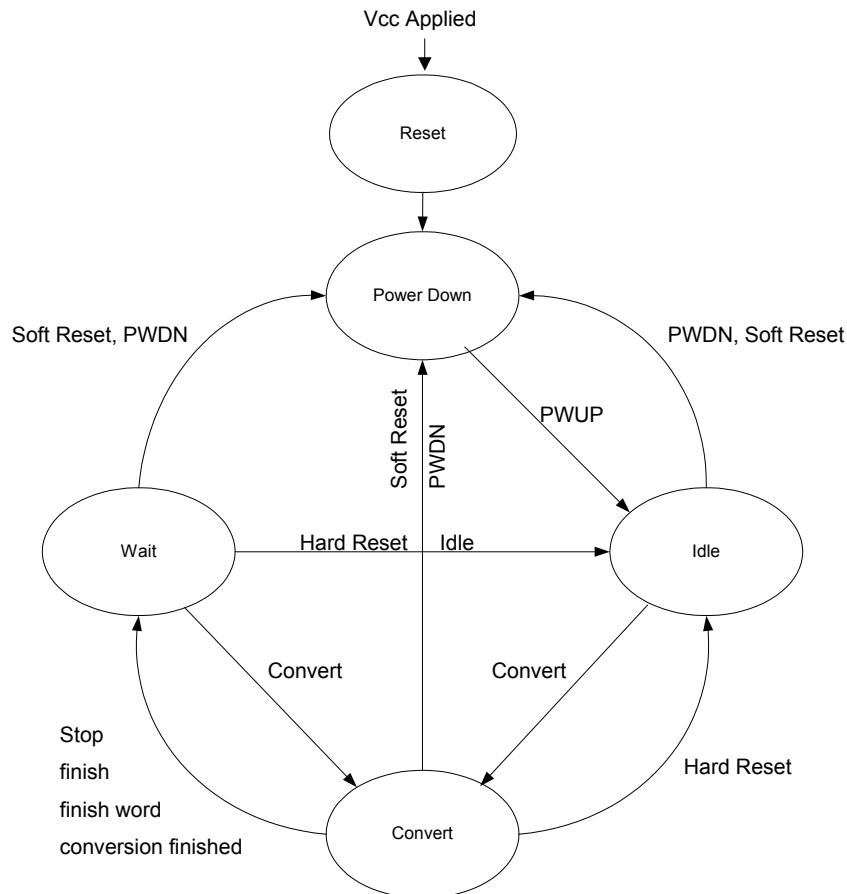

Figure 10. WTS701 Processor States



RESET

The WTS701 processor is initialized to the RESET state when Vcc is first applied to the part.

After a reset condition the device enters the POWER DOWN state. All configuration registers are initialized to their default values after issuing the PWUP command.

Once the WTS701 is active and a hardware reset is applied on the RESET pin, the WTS701 will be in IDLE state, and all configuration registers will return to their default values.

POWER DOWN

In this state, the power consumption of the WTS701 is minimal. All analog outputs are tristate, the crystal interface is deactivated and the microcontroller is stopped. The only commands valid in the Power Down mode are PWUP, SCLC and RDST. All configuration registers will return to their default values after issuing the PWUP command.

IDLE

The idle state is first entered with the PWUP command. In this state, the micro-controller is running and the device is ready to respond to further commands. From the IDLE state, the device can go to the active CONVERT state or the POWER DOWN state.

CONVERT

This state is initiated by the CONV command. The text located in the internal buffer is converted into speech and played back to the analog or digital interface according to the state of the configuration registers. Once the active conversion has finished, the device enters the WAIT state.

WAIT

Once a conversion has finished, the device enters the WAIT state. In this state, audio outputs are still active. To deactivate, audio outputs and return to the IDLE state an IDLE command is issued.



7.4.5 Initialization and Configuration

Configuration

After power-on or a Reset command (RST) the WTS701 processor can be configured for operation. This involves initializing the internal configuration registers for the users requirements.

Table 11. Initialization Command Sequence

State	Command	Description
POWER DOWN	-----	State after power-on or RST command.
	SCLC	Set clock configuration.
	PWUP	Power up device.
IDLE	SCOM	Set up communication register to enable interrupts.
	SCOD	Set up CODEC configuration (if used).
	SAUD	Set up audio control register.
	SVOL	Set the initial volume level.
	SSPD	Set the initial speech output speed level.
	SPTC	Set the initial speech pitch level.

7.4.6 Converting Text

After configuration, the WTS701 is ready for text-to-speech conversion. Because of the real-time nature of speech, some form of flow control is necessary to inform the host system:

1. When the device is ready for more text data
2. When the device has finished converting text
3. When the device can release the audio interface

The CONVERT state is entered by sending a CONV command along with some textual data. The WTS701 has an internal 256-byte buffer to accept text data. The R/B signal (both the hardware line and the status bit) will become active (LOW):

1. When the internal buffer is full
2. If the host sends data at a rate too fast for the WTS701 to process it to the internal buffer

When R/B becomes active the user may:

1. Wait for the R/B pin to return to the (HIGH) ready state
2. Terminate the SPI transaction until a later time and resend the data



The user has the choice of enabling interrupts to signal the host when there is free space in the internal buffer. When all text data has been sent, the user must indicate this by:

1. Sending a FIN (Finish) command
2. Sending an EOT (ASCII 0x1A) character as the last byte of a CONV command (MANDARIN UNICODE/Big5 0x00 0x1A)

When conversion has been terminated using either of these commands, another CONV command cannot be sent until conversion is completed and the chip enters the WAIT state.

Notes

1. Buffer length limit:
The max. character length of a white-space-bounded string is 53. The exceeding characters will be truncated.
2. Undefined characters:
All the undefined characters will be deleted (prior to the word pronunciation process). The defined characters range from '0x00' to 0x7A' excluding '0x22', '0x3C', '0x3E' and '0x60'.

Once the WTS701 has synthesized the contents of the text buffer, it will enter the WAIT state. In this state the audio interface is still active. To disable the audio interface and return to the IDLE state an IDLE command is sent. The WAIT state can be detected either through polling of the CNVT bit or enabling of the ICNV interrupt. An example of the flow for a conversion is shown in [Figure 11](#). The flow here assumes that the COM register is set such that the WTS701 generates an IBUF interrupt at the 75 percent buffer level (64 free bytes) and that the ICNV interrupt is enabled.

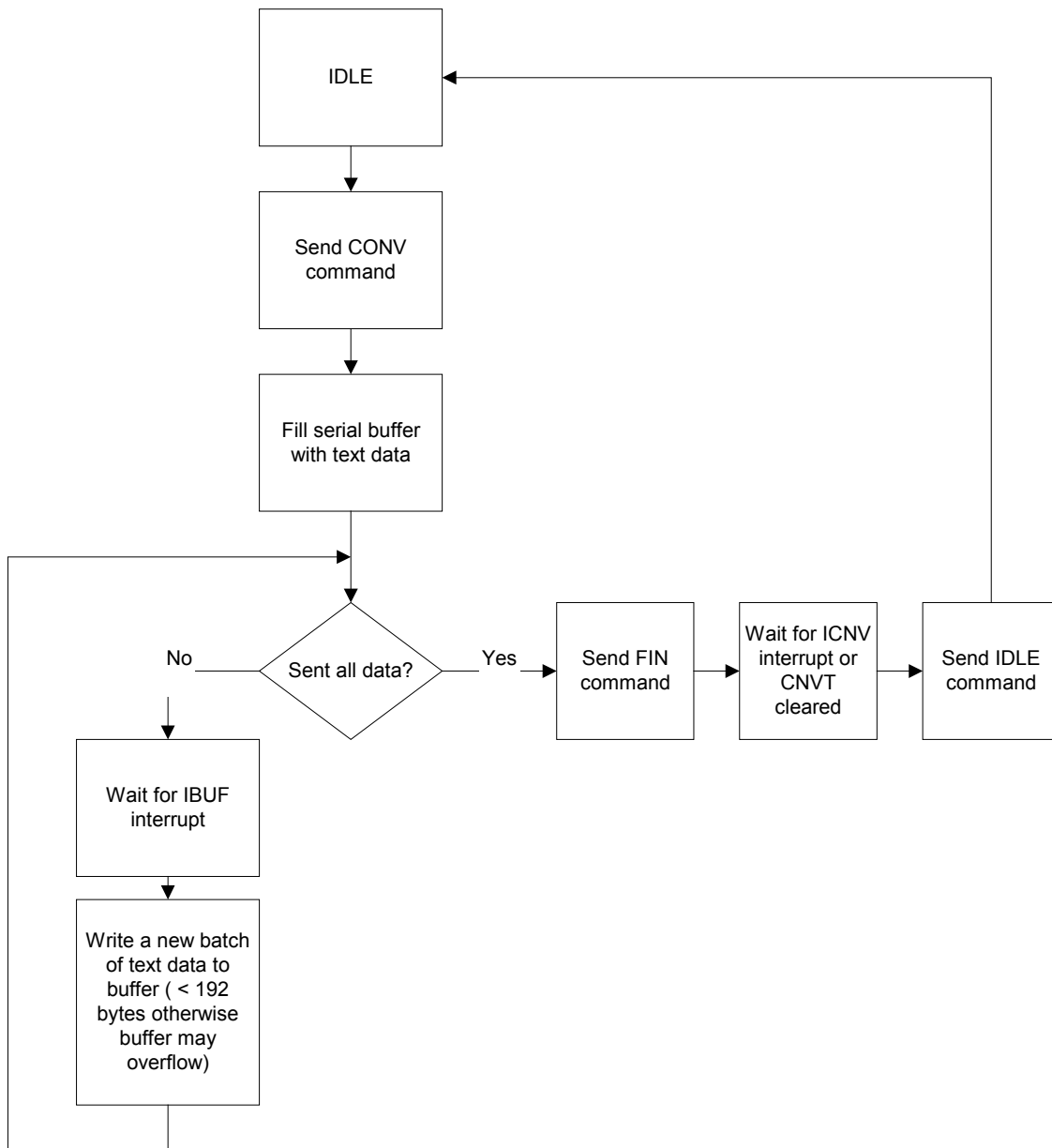

Figure 11. Flow Diagram for Convert Operation.



Controlling Text Conversion

The WTS701 offers several features to control text conversion. The PAUS (Pause) and RES (Resume) commands allow the host to pause and then continue speech output. The FINW command allows the host to end a conversion after the next whole word is spoken. The ST (Stop) command will terminate a conversion immediately – even mid-word. To allow more advanced control, the WTS701 allows the host to interrogate the byte count register, which keeps track of the position in the input stream that is currently being spoken. If the host wishes to repeat a spoken word, it should:

1. Read the byte count register
2. Send a FINW or ST command
3. Wait for ICNV
4. Send a new CONV command resending the data starting at the desired number of bytes, according to the repeated spoken words, prior to the count returned in the byte count

In a similar way a skip function could be implemented to skip ahead words or sentences.

7.5 SPI INTERFACE

The SPI interface consists of the 4-wire bus \overline{SS} , SCLK, MOSI and MISO. In addition, flow control protocols are implemented via the $\overline{R/B}$ signal and/or the WTS701 Status register transmitted via MOSI. The WTS701 processor also has the option to communicate with the host via interrupt services requested by the interrupt request line. The timing and behavior of these signals is dependent upon the command class being executed, i.e., commands with or without associated data. Additionally the use of the $\overline{R/B}$ hardware control line is not compulsory; rather the host can monitor the $\overline{R/B}$ bit of the status register to determine when data has been accepted. The status register also contains the ICMD bit. This bit is set to indicate an SPI transaction has been ignored, indicating that the WTS701 processor is unable to service a new command. Asynchronous (Class 0) commands are always accepted. For more information, refer to subsection [7.3.1](#) which describes the command classes.

7.5.1 SPI Transactions

SPI Transactions with the WTS701 are broken down into four classes and four basic types:

Type I - Single Word Transactions

Single word transactions are Class 0 or Class 1 commands that have no data to transmit or transmit all required data in the command data byte. $\overline{R/B}$ will never become active for these commands. ICMD could be active for a Class 1 command if the WTS701 is still interpreting the previous command.

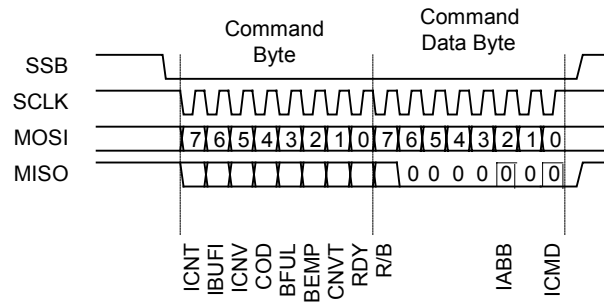

Figure 12. Type I SPI Transaction.

Type II – Two Word Transactions that Receive Data

Type II transactions are four byte transactions that read out the byte count register. As these commands are all Class0, ICMD will never be active and $\overline{R/B}$ will never occur.

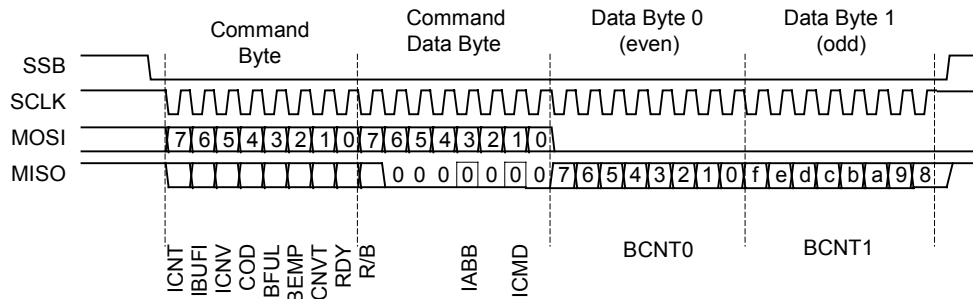

Figure 13. Type II SPI Transaction.

Type III – Transactions that send data

Type III transactions send data to the WTS701. If the data rate exceeds the ability of the WTS701 to read data from the input FIFO or if the internal data queue becomes full then the $\overline{R/B}$ line will handshake a pause in the SPI transaction. The host can either:

- Wait for $\overline{R/B}$ to return HIGH then continue sending data
- Terminate the transaction and try sending data later

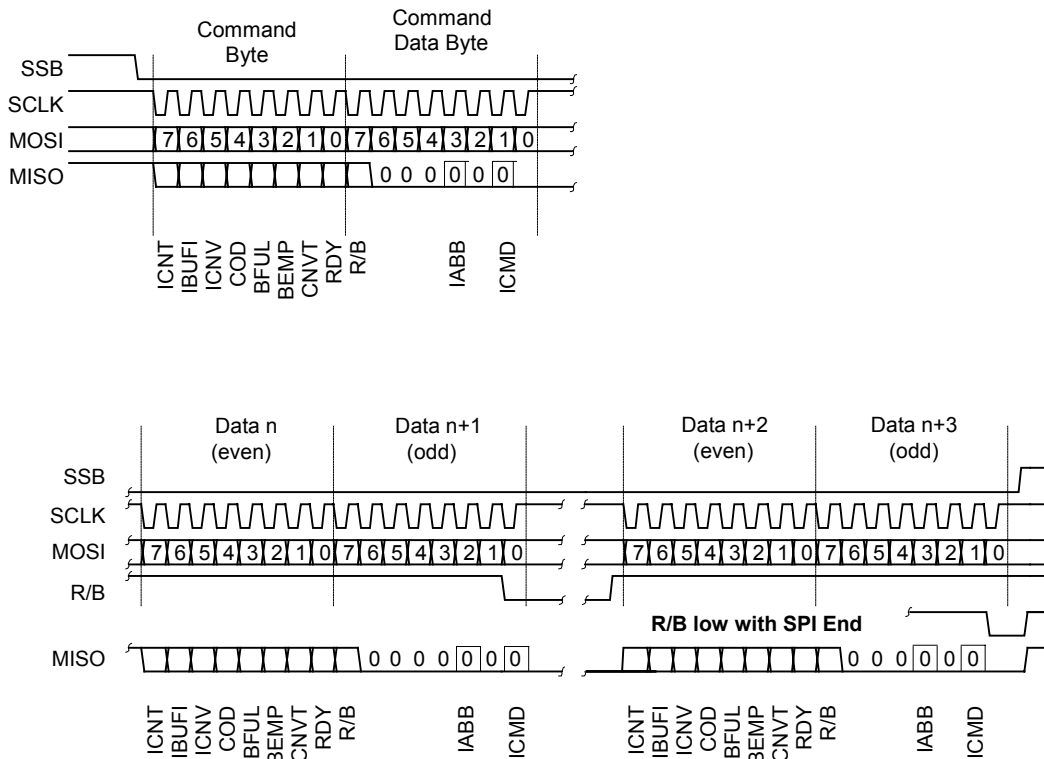

Figure 14. Type III SPI Transaction.

Type IV – Transactions reading data

Type IV transactions read data from the WTS701. Because of the latency required for the WTS701 to place data in the output register, $\overline{R/B}$ must be monitored.

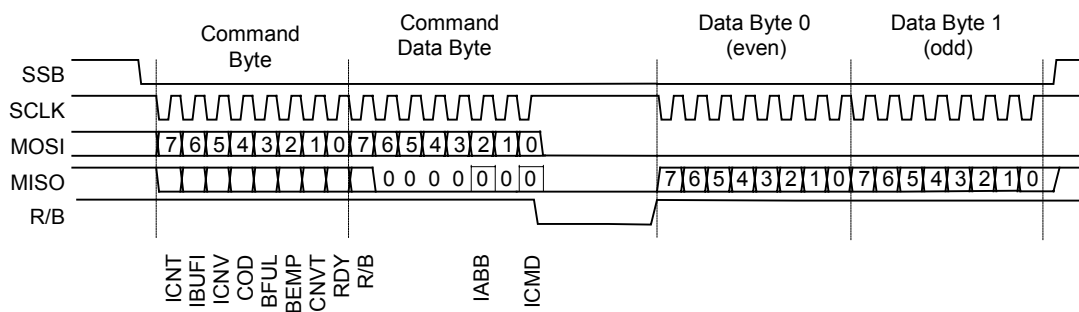

Figure 15. Type IV SPI Transaction.



7.6 CODEC INTERFACE

The WTS701 processor supports analog and digital telephony in various configurations. The WTS701 can be used in digital environments, along with a DSP that controls a CODEC. Therefore, the WTS701 is configured to operate in slave mode, where the control signals are provided by an external source, which is usually the DSP. It supports a variety of single channel CODECs, examples of which are listed in [Table 12](#).

The CODEC interface is designed to send data in short frame format as well as long frame format. The channel width is 13 or 16 bits linear, the precision of the output is 10 bits. The operation mode of the CODEC is configured by the COD configuration register and SCOD command. See subsection [7.4.3](#) for details.

- The CODEC can be configured to transmit data in the unsigned or 2's Complement mode (see [Table 13](#) for details).
- The CODEC responds to both the Long and Short sync format (see [Figure 16](#) and [Figure 17](#)).
- The CODEC can be configured to tristate the VDX line after 13 or 16 bits.

Table 12. Supported CODEC Examples.

Manufacturer	CODEC Device Name	Characteristics	Operating Voltage	Conversion Type	Data Format
OKI	ML7041	Single codec	3 V	14-bit linear	2s Complement
OKI	MSM7716	Single codec	3 V	14-bit linear	2s Complement
OKI	MSM7732-011	Single codec	3 V	14-bit linear	2s Complement
Motorola	MC145483	Single codec	3 V	13-bit linear	2's Complement
Lucent	T8538B	Quad codec	3.3 V	16-bit linear	2's Complement



Table 13. CODEC Transmission Modes.

Level	Signed Mode (2's Complement)			Unsigned Mode	
	Sign Bit (MSB)	13 Bit Mode	16 Bit Mode	13 Bit Mode	16 Bit Mode
+ve full scale	0	1111 1111 1000	1111 1111 1000 0000	1 1111 1111 1000	1111 1111 1100 0000
+1 LSB	0	0000 0000 1000	0000 0000 1000 0000	1 0000 0000 1000	1000 0000 0100 0000
Zero (ground)	0	0000 0000 0000	0000 0000 0000 0000	1 0000 0000 0000	1000 0000 0000 0000
-1 LSB	1	1111 1111 1000	1111 1111 1000 0000	0 1111 1111 1000	0111 1111 1100 0000
-ve full scale	1	0000 0000 0000	0000 0000 0000 0000	0 0000 0000 0000	0000 0000 0000 0000

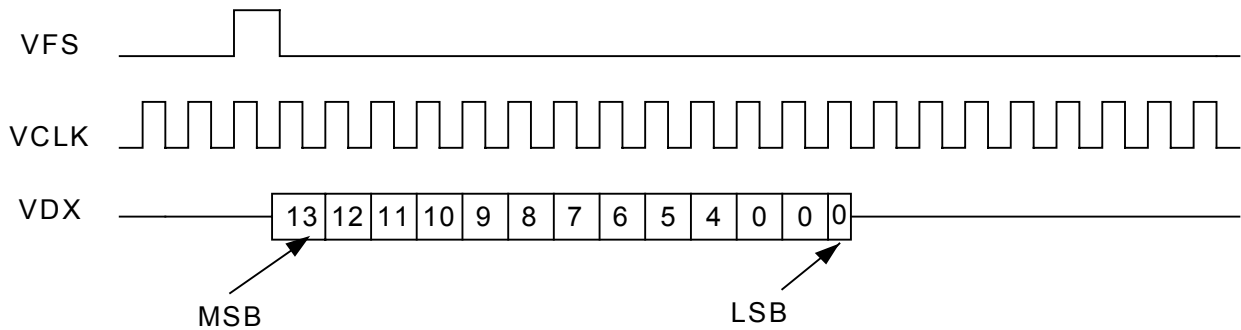

Figure 16. CODEC Protocol, 13 bit, Short Frame Sync.

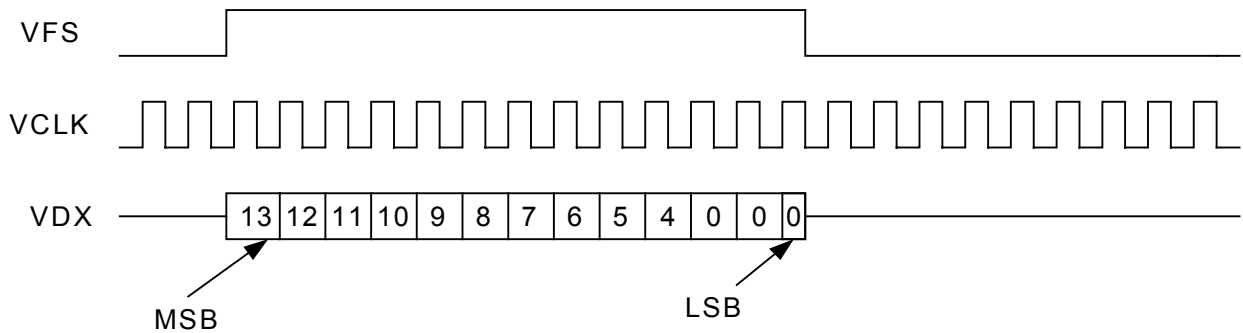

Figure 17. CODEC Protocol, 13 bit, Long Frame Sync.

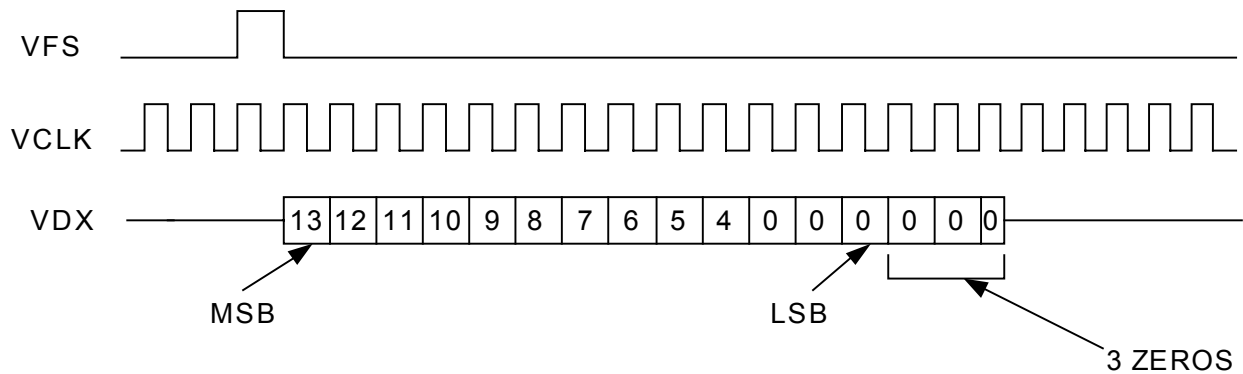

Figure 18. CODEC Protocol, 16 bit, Short Frame Sync.

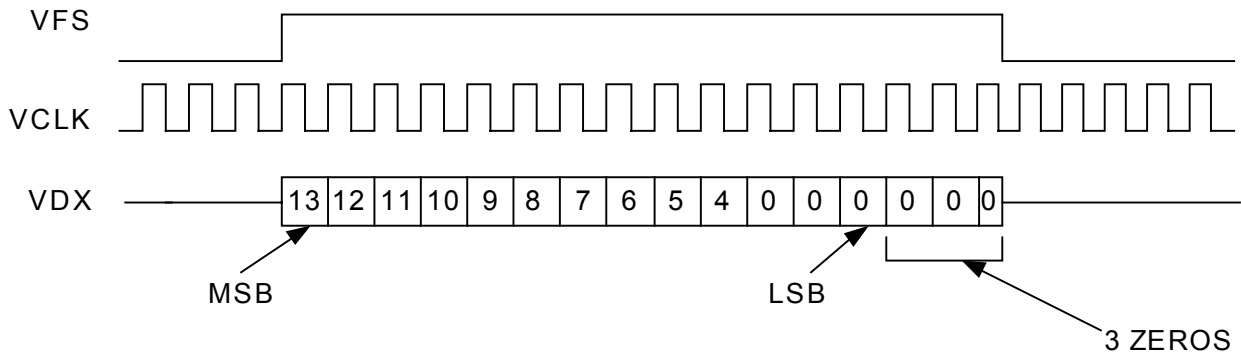

Figure 19. CODEC Protocol, 16 bit, Long Frame Sync.

7.7 CONTROL CHARACTERS

The WTS701 allows receiving control characters embedded in the text sent in the Convert command to better emphasize word or alter meaning of sentence. The control characters supported are for phonetic alphabet playback, speed, volume modification and case sensitivity behavior.

7.7.1 Phonetic Alphabet Playback

The WTS701 uses an intermediate phonetic translation represented as an alphabet that represents phonemes and stress for each input word. This feature allows the text sent to the WTS701 to consist of a combination of ASCII characters as well as phonetic alphabet. This capability offers the flexibility to send words already processed for phonetic representation, achieving the desired pronunciation.

Phonetic strings can be sent directly to the WTS701. This can be done by embedding phoneme strings in the text stream for conversion. To embed a phoneme string, the string must be preceded by a control-P (^P, ASCII 0x10) character and terminated by a space character.

For example:

“The quick ^Pbr1Wn fox.”

The following table lists the phoneme symbols acceptable by the WTS701E (English software version). As the acceptable phoneme symbols are language dependent, please refer to the specific language User’s Guide for details regarding characters accepted and other development considerations.

Table 14. Acceptable Phoneme Symbols.

Vowels			Consonants		
Phoneme	Hex Value	Example	Phoneme	Hex Value	Example
i	0x69	beat	p	0x70	pet
l	0x49	bit	t	0x74	ten
e	0x65	bait	k	0x6b	kit
E	0x45	bet	b	0x62	bet
@	0x40	bat	d	0x64	debt
u	0x75	boot	g	0x67	get
U	0x55	book	h	0x68	hat
o	0x6f	boat	f	0x66	fat
c	0x63	bought	T	0x54	thing
a	0x61	Bob	D	0x44	that
A	0x41	but	s	0x73	sat
R	0x52	burr	S	0x53	shut
O	0x4f	boy	v	0x76	vat
Y	0x59	buy	z	0x7a	zoo
W	0x57	down	Z	0x5a	azure
x	0x78	about	y	0x79	you
X	0x58	roses	w	0x77	wit
			r	0x72	rent
			l	0x6c	let
			m	0x6d	met
			n	0x6e	net
			G	0x47	sing
			C	0x43	church
			J	0x4a	Judge
			P	0x50	Butter*
			Q	0x51	Written*

Note that each phoneme is represented by exactly one character and each vowel is preceded by a *stress symbol*.

* Female English only.



Numbers 1 and 0 represent stress: each word has a single 1 stress, representing the main stress of the word; all other syllables have 0 stress.

Examples:

Input	Phonetic translation
hi.	h1Y (phoneme /h/, followed by a 1-stress vowel phoneme Y)
test	t1Est
testing	t1Est0IG

Special Characters in Text Input String

These characters inserted into the ASCII text are used to modify the behavior for special circumstances.

0x10 ^P This control flag indicates a phoneme string follows immediately (e.g. '^Ppr0Ez0Intles0In').

0x11 ^Q Pauses with variant length can be added within a sentence by using the '^QX' flag. 'X' is an integer which indicates the pause duration ('X' is 0.1 sec per unit). For instance, '^Q10' will add in a 1-second pause.

It is important to remember that all the text following these special characters will be subjected to the same special conditions. If a ^V+ command precedes a word then all the following words will be spoken louder. If a single word is to be emphasized then the ^V+ must be ahead of the word and a ^V- must follow.

7.7.2 Speed Change

The rate of speech can be changed by sending an SPI command to modify the speed or by adding a control character to control the speed in real-time.

0x13 ^S Speed Change Flag. A space character is required after the control characters before the input text string.

- ^S+: Increase speed by 1 (e.g. '^S+ Hello world').
- ^S-: Decrease speed by 1.
- ^SX: Set the speed to X. X starts from 0 to 4 (e.g. '^S1 Hello world').

Any number that is greater than 4 will be set to 4.

It's the user's responsibility to verify the WTS701 speed setting before sending a control character and/or SPI command that modify speed.



7.7.3 Volume Change

The speech volume can be changed by sending SPI command to modify the speed or by adding control character to control the volume in real-time.

0x16 ^V Volume Change Flag. A space character is required after the control characters before the input text string.

- ^V+: Increase volume by 1 (e.g. '^V+ Hello world').
- ^V-: Decrease volume by 1.
- ^VX: Set the volume to X. X starts from 0 to 7 (e.g. '^V1 Hello world').

Any number that is greater than 7 will be set to 0.

It's the user's responsibility to verify the WTS701 volume setting before sending a control character and/or SPI command that modify volume.

7.7.4 Case Sensitivity

The way upper/lower case is handled can be changed by adding a control character in the text sent to control the case sensitivity behavior in real-time.

0x15 ^U All-Uppercase Word (all CAPs) Control Flag. This flag controls interpretation of strings with all uppercase letters. A space character is required after the control characters before the actual input text string.

- ^U0: This is the default setting. Some all-uppercase words (all CAPs) are spelled out, but others are treated as ordinary words, abbreviations, Roman numerals, ect. (e.g. '^U0 IBM equals 'i b m').
 - ^U1: Avoid spelling out all-uppercase words. Any all-uppercase word in the input string will NOT be spelled out unless the system determines that the word is not pronounceable. In this mode, there is no abbreviation support (e.g. '^U1 NOKIA' equals 'nokia').
 - ^U2: Spell out all words, regardless of case. All words in the input sting are spelled out in this mode. There is no abbreviation support in this mode (e.g. '^U2 NOKIA' equals 'n o k i a').
- ^U3: Force the all-capital words/strings to be spelled out regardless of string length. For instance, '^U3 HELLO' will be pronounced as 'H', 'E', 'L', 'L', 'O'.

7.7.5. Pause Control

Pause control flage: '^QX': Pauses with variant length can be added within a sentence by using the '^QX' flag. 'X' is an integer which indicats the pause duration ('X' is 0.1 sec per unit). For instance, '^Q10' will add in a 1-second pause.



7.8 CUSTOMIZING ABBREVIATIONS

The WTS701 has support for entering and using custom abbreviations in addition to the general abbreviation table supported internally by the WTS701. There are 2K bytes of flash memory reserved for this purpose. After the WTS701 internal software has been initially programmed, this entire area is free and available for custom abbreviations.

The commands associated with custom abbreviations are:

Command	Command Byte	Command Data Byte	
ABBR_ADD	0xaf	0x00 + abbreviation data.	Adds a new abbreviation to the abbreviation table in the WTS701. See next page for the format of the abbreviation data.
ABBR_DEL	0x83	0x00+ abbreviation data.	Deletes an existing abbreviation from the abbreviation table in the WTS701. See next page for the format of the abbreviation data.
ABBR_NUM	0xc8	0x00 + 0x00 + 0x00.	Returns the number of abbreviation currently active in the abbreviation table of the WTS701.
ABBR_MEM	0xc7	0x00 + 0x00 + 0x00.	Returns the number of free bytes in the abbreviation table of the WTS701.
ABBR_RD	0xc9	0x00 + 2048 0x00s.	Returns the abbreviation table contents from the WTS701. See next page for the format of the abbreviation table data.
ENTER_RRSM	0x0c	0x00	Causes the xdata and code store memory to swap spaces. The WTS701 begins to execute code previously stored into xdata after this command.

7.8.1 Abbreviation Data Format

The format of the abbreviation data that is sent with the ABBR_ADD and ABBR_DEL commands is:

XXX + “,” + YYYY + “;”.

XXX - the abbreviation characters.

“,” – comma.

YYYY – abbreviation text.



“;” – semi-colon.

Example: TTS;text to speech; After this is added using the ABBR_ADD command, when the text “TTS” is sent as part of the convert data, the WTS701 will speak “text to speech” instead of T T S.

Note: when deleting an abbreviation, the abbreviation text is optional.

To delete the TTS example, only “TTS;” is necessary.

7.8.2 Abbreviation Table Format

The format of the abbreviation table returned with the ABBR_RD command is:

Abbreviation entry - Marker + Count + XXX + 0x00 + YYYY + 0x00.

Marker – The marker will be either 0xfe for active abbreviation or 0xfc for a deleted abbreviation.

Count – The byte count for this entry including the Marker, Count, XXX, YYYY, and zeros.

XXX – the abbreviation characters.

0x00 – Null terminator.

YYYY – abbreviation text.

0x00 – Null terminator.

The unused data are always 0xff.

7.8.3 Command Execution

ABBR_NUM & ABBR_MEM - These commands are executed by sending the command and command data, waiting for R/B to be ready, then receiving two bytes from MISO. The first byte received is the MSB, and the second is LSB.

ABBR_RD – This command is executed by sending the command and command data, waiting for R/B to be ready, then receiving 2048 characters (the entire abbreviation table).

ABBR_ADD & ABBR_DEL – These commands are executed by sending the command and command data, followed by the abbreviation data formatted as described in subsection [7.8.1](#). When the WTS701 is ready for the next step, it will generate an IABB interrupt. After the interrupt, send the ENTER_RSSM (0x0c + 0x00) command. After issuing the command wait for 100ms. After the timeout, the WTS701 will have programmed the new abbreviation entry and be ready to accept more commands. Adding or removing an abbreviation will reset the configuration registers to their default values.



After abbreviation entry deletion, the abbreviation entry is only deleted from the table and not used, however it still holds memory space. The only way to free all memory will be to reprogram the WTS701 firmware into the device.

7.9 DEVICE PROGRAMMING

The WTS701 is fully programmable to support different available languages or different voices that can be loaded to the device whenever the user wishes to do so. The language or the voice module should be stored externally and transmitted to the WTS701 processor with regards to a specific protocol defined in this section.

Programming the WTS701 consists of downloading a binary executable to the processor code memory and a digitized analog speech corpus to the non-volatile analog multi-level storage (MLS). Winbond will supply code as a set of ASCII readable data files. The information will be provided to qualified customers upon request.



7.10 TEXT-TO-SPEECH PROCESSOR COMMANDS – QUICK REFERENCE TABLE.

Status Commands										
Command			Description	Opcode Hex		Previous State	Result State	Command Parameters		Return Value
Name	Class	Type		Command byte	Command data			Description	Bytes	
RDST	0	II	Read Status	04	00	Idle, Convert, Power Down	No change	None	-	Byte count
RINT	0	II	Read Interrupt	06	00	Idle, Convert	No change	None	-	Byte count
RVER	0	II	Read version	12	00	Idle, Convert	No change	None	-	Hw_ver, Sw_ver



System Commands											
Command			Description	Opcode Hex		Previous State	Result State	Command Parameters		Return Value	
Name	Class	Type		Command byte	Command data			Description	Bytes	Description	Bytes
PWUP	0	I	Exit Power Down mode	02	00	Power Down	Idle	None	-	None	-
PWDN	1	I	Go To Power Down mode	40	00	Idle, Convert Wait	Power Down	None	-	None	-
RST	0	I	Reset	10	00	Idle, Convert Wait, Power down	Power Down	None	-	None	-



Synthesis Commands											
Command			Description	Opcode Hex		Previous State	Result State	Command Parameters		Return Value	
Name	Class	Type		Command byte	Command data			Description	Bytes	Description	Bytes
CONV	2	III	Convert text	81	00	Idle, Wait	Convert	Text data	N	None	-
PAUS	1	I	Pause conversion	49	00	Convert	No change	None	-	None	-
RES	1	I	Resume conversion	4A	00	Convert	No change	None	-	None	-
ST	1	I	Stop conversion	4B	00	Convert	Wait	None	-	None	-
FINW	1	I	Finish word	4D	00	Convert	Wait	None	-	None	-
FIN	1	I	Finish	4C	00	Convert	Wait	None	-	None	-
VLUP	1	I	Volume up	53	00	Idle, Convert Wait	No change	None	-	None	-
VLDN	1	I	Volume down	54	00	Idle, Convert Wait	No change	None	-	None	-
SPUP	1	I	Speed up	55	00	Idle, Convert Wait	No change	None	-	None	-
SPDN	1	I	Speed down	56	00	Idle, Convert Wait	No change	None	-	None	-
IDLE	1	I	Switch to Idle state	57	00	Wait, Convert	Idle	None	-	None	-

Configuration Commands										
Command			Description	Opcode Hex		Previous State	Result State	Command Parameters		Return Value
Name	Class	Type		Command byte	Command data			Description	Bytes	Description
RREG	3	IV	Read configuration register	C0	Register Number	Idle, Convert	No change	None	-	Register value, dummy byte
SCOM	1	I	Set COM register	4E	Value	Idle, Wait	No Change	None	-	None
SCOD	1	I	Set COD register	4F	Value	Idle, Wait	No Change	None	-	None
SAUD	1	I	Set AUD register	50	Value	Idle, Wait	No Change	None	-	None
SVOL	1	I	Set VOL register	51	Value	Idle, Wait	No Change	None	-	None
SSPD	1	I	Set SPD register	52	Value	Idle, Wait	No Change	None	-	None
SCLC	1	I	Set CLC register	14	Value	Idle, Wait	No Change	None	-	None
SPTC	1	I	Set Speech Pitch	77	Value	Idle, Wait	No Change	None	-	None



Customization Commands										
Command			Description	Opcode Hex		Previous state	Result State	Command Parameters		Return Value
Name	Class	Type		Command byte	Command data			Description	Bytes	
ABBR_NUM	3	IV	Return number of abbreviation entries	C8	00	Idle	No change	None	-	Num_of_entries
ABBR_RD	3	IV	Read abbreviation table	C9	00	Idle	No change	None	-	Abbreviation table entries
ABBR_MEM	3	IV	Return abbreviation memory	C7	00	Idle	No change	None	-	Available_mem
ABBR_ADD	2	III	Add abbreviation	AF	00	Idle	No change	Abbreviation information	N	None
ABBR_DEL	1	I	Delete abbreviation entry	83	00	Idle	No change	Abbreviation information	N	None
ENTER_RRS_M	0	I	Swap memory	0C	00	Idle	No change	None	-	None



7.10.1 Text Input Format

The following table lists the ASCII characters acceptable by the WTS701E (English software version). Please refer to the specific language User's Guide for more details regarding characters accepted and other development considerations.

Note: Unexpected behavior may occur if the input text contains characters that are not defined in this ASCII table.

Table 15. Allowable ASCII Characters.

0x0		0x20	Space	0x40	@	0x60	
0x1		0x21	!	0x41	A	0x61	a
0x2		0x22		0x42	B	0x62	b
0x3		0x23	#	0x43	C	0x63	c
0x4		0x24	\$	0x44	D	0x64	d
0x5		0x25	%	0x45	E	0x65	e
0x6		0x26	&	0x46	F	0x66	f
0x7		0x27	' (apostrophe)	0x47	G	0x67	g
0x8		0x28	(0x48	H	0x68	h
0x9		0x29)	0x49	I	0x69	i
0xa		0x2a	*	0x4a	J	0x6a	j
0xb		0x2b	+	0x4b	K	0x6b	k
0xc		0x2c	, (comma)	0x4c	L	0x6c	l
0xd		0x2d	- (dash)	0x4d	M	0x6d	m
0xe		0x2e	. (period)	0x4e	N	0x6e	n
0xf		0x2f	/ (slash)	0x4f	O	0x6f	o
0x10	^P	0x30	0	0x50	P	0x70	p
0x11	^Q	0x31	1	0x51	Q	0x71	q
0x12		0x32	2	0x52	R	0x72	r
0x13	^S	0x33	3	0x53	S	0x73	s
0x14		0x34	4	0x54	T	0x74	t
0x15	^U	0x35	5	0x55	U	0x75	u
0x16	^V	0x36	6	0x56	V	0x76	v
0x17		0x37	7	0x57	W	0x77	w
0x18		0x38	8	0x58	X	0x78	x
0x19		0x39	9	0x59	Y	0x79	y
0x1a	EOT	0x3a	: (colon)	0x5a	Z	0x7a	z
0x1b		0x3b		0x5b] (right bracket)	0x7b	
0x1c		0x3c		0x5c	\ (back slash)	0x7c	
0x1d		0x3d	=	0x5d	[(left bracket)	0x7d	
0x1e		0x3e		0x5e		0x7e	
0x1f		0x3f	?	0x5f	_ (under score)	0x7f	



7.10.2. Buffer length limit

The max. character length of a white-space-bounded string is 53. The exceeding characters will be truncated.

7.10.3. Undefined characters

All the undefined characters will be deleted (prior to the word pronunciation process). The defined characters range from '0x00' to '0x7A' excluding '0x22', '0x3E', and '0x60'.

8. TIMING WAVEFORMS

8.1 SPI TIMING DIAGRAM

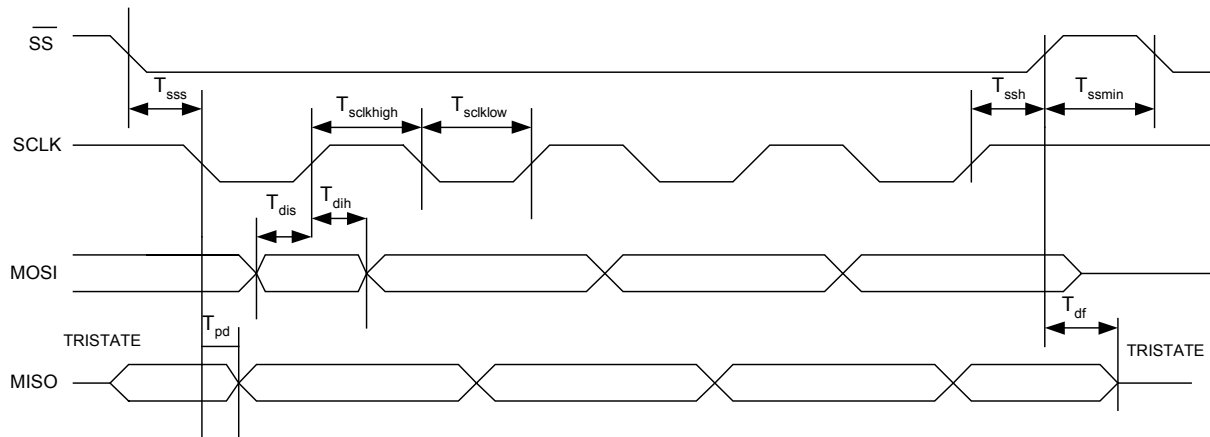

Figure 20. SPI Timing Specification.

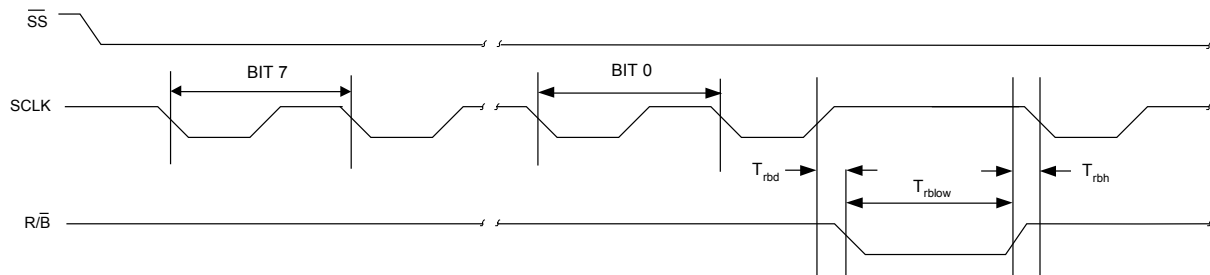

Figure 21. SPI R/B Timing.

Table 16. SPI Timing Parameters (see [Figure 20](#) and [Figure 21](#))

Symbol	Parameters	Min	Typ ⁽⁷⁾	Max	Units	Conditions
T_{SSS}	\overline{SS} Setup Time	100			ns	
T_{SSH}	\overline{SS} Hold Time	100			ns	
T_{DIS}	Data in Setup Time	50			ns	
T_{DIH}	Data in Hold Time	50			ns	
T_{PD}	Output Delay			100	ns	
T_{DF}	Output Delay to hiZ			100	ns	
T_{SSmin}	\overline{SS} High	200			ns	
T_{SCKhi}	SCLK High Time	80			ns	
T_{SCKlow}	SCLK Low Time	80			ns	
T_{rbd}	Delay SCLK Hi to $\overline{R/B}$ low			80	ns	
T_{rblow}	$\overline{R/B}$ low time	0			ms	
T_{rbh}	SCLK hold time from $\overline{R/B}$ \ High	0				
F_O	CLK Frequency			5000	KHZ	

8.2 CODEC TIMING DIAGRAMS

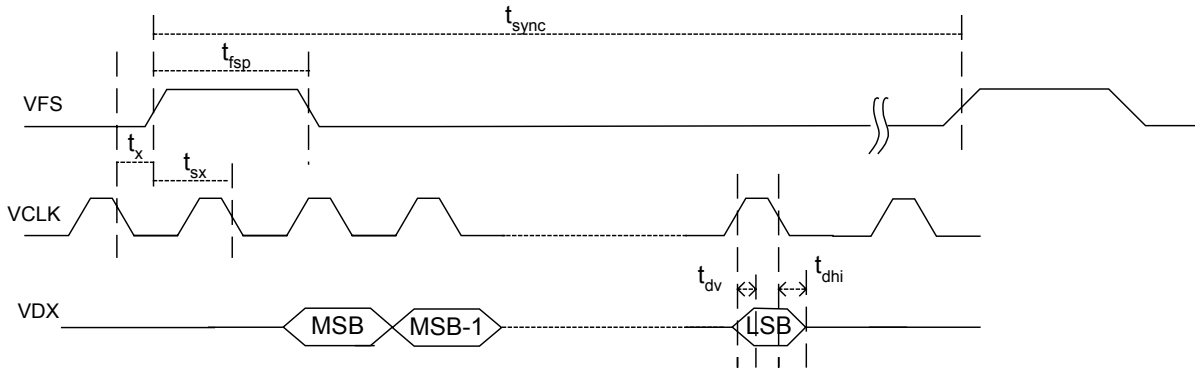

Figure 22. CODEC Timing — Short Frame Sync.

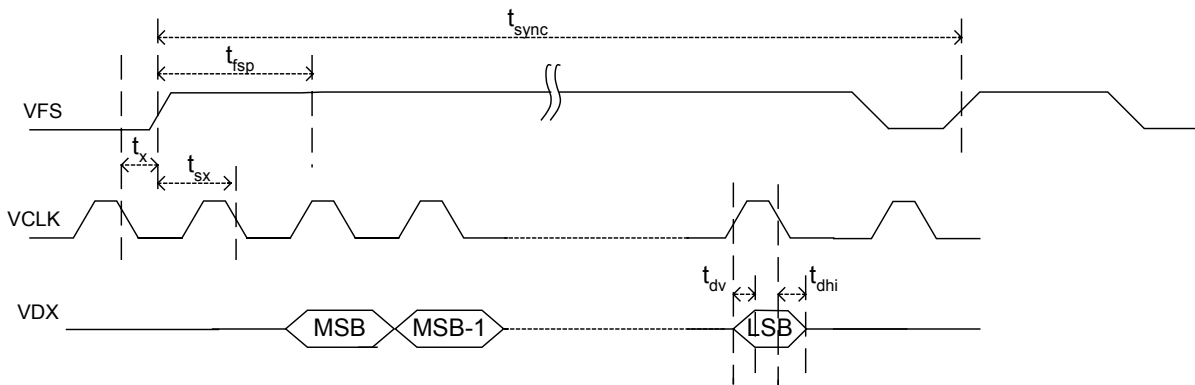

Figure 23. CODEC Timing -- Long Frame Sync.

Table 17. CODEC Timing Parameters (see [Figure 22](#) and [Figure 23](#))

Symbol	Parameters	Min	Typ ⁽⁷⁾	Max	Units	Conditions
T _{clk}	Bit clock frequency	128		2048	kHz	
T _{sync}	Frame Sync. Frequency		8		kHz	
D _C	Clock Duty Cycle	45	50	55	%	
T _{ir}	Rise Time			50	ns	All digital inputs
T _{if}	Fall Time			50	ns	All digital inputs
T _{fsp}	Frame Sync. Pulse Width			100	ns	VFS
T _{rs}	Receive Sync. Timing	20			ns	VCLK to VFS
T _{sr}	Receive Sync. Timing	80			ns	VFS to VCLK
T _{dv}	Output Delay Time for VDX Valid	10		140	ns	VCLK to VDX
T _{dhi}	Output Delay Time for VDX High Impedance	10		140	ns	VCLK to VDX



9. ABSOLUTE MAXIMUM RATINGS

Table 18. Absolute Maximum Ratings (Packaged Parts) ⁽¹⁾

Condition	Value
Junction temperature	150 ⁰ C
Storage temperature range	-65 ⁰ C to +150 ⁰ C
Voltage Applied to any pin	(V _{SS} - 0.3V) to (V _{CC} + 0.3V)
Voltage applied to any pin (Input current limited to +/-20 mA) ⁽²⁾	(V _{SS} - 1.0V) to (V _{CC} + 2.2V)
Lead temperature (soldering – 10 seconds)	300 ⁰ C
V _{CC} - V _{SS}	-0.3V to +7.0V

Table 19. Operating Conditions (Packaged Parts).

Condition	Value
Commercial operating temperature range ⁽³⁾	0 ⁰ C to +70 ⁰ C
Extended operating temperature ⁽²⁾	-20 ⁰ C to +70 ⁰ C
Industrial operating temperature ⁽²⁾	-40 ⁰ C to +85 ⁰ C
Supply voltage (V _{CC}) ⁽⁴⁾	+2.7V to +3.3V
Ground voltage (V _{SS}) ⁽⁵⁾	0V

¹ Stresses above those listed may cause permanent damage to the device. Exposure to the absolute maximum ratings may affect device reliability. Functional operation is not implied at these conditions.

² All input pins except for $\overline{\text{CS}}$ signal, which is 3V tolerant ONLY.

³ Case Temperature.

⁴ V_{CC} = V_{CCA} = V_{CCD}.

⁵ V_{SS} = V_{SSA} = V_{SSD}



10. ELECTRICAL CHARACTERISTICS

($V_{CC} = 3.3V$, $V_{SS} = 0V$, $T_A = 0$ to 70 °C)

Table 20. General Parameters.

PARAMETER	SYMBOL	TEST CONDITIONS	SPEC			UNIT
			MIN ⁽⁶⁾	TYP ⁽⁷⁾	MAX.	
Input LOW Voltage	V_{IL}				$V_{CC} \times 0.2$	V
Input HIGH Voltage	V_{IH}		$V_{CC} \times 0.8$			V
Output LOW Voltage	V_{OL}	$I_{OL} = 10 \mu A$			0.4	V
R/B, INT Output LOW Voltage	V_{OL1}	$I_{OL} = 1 \text{ mA}$			0.4	V
Output HIGH Voltage	V_{OH}	$I_{OL} = -10 \mu A$	$V_{CC} - 0.4$			V
V_{CC} Current (Operating)	I_{CC}					
- Convert		No Load ⁽⁸⁾			50	mA
- Idle		No Load ⁽⁸⁾			20	mA
- CODEC		No Load ⁽⁸⁾			20	mA
- Speaker		No Load ⁽⁸⁾			15	mA
V_{CC} Current (Standby)	I_{SB}	(8)		1	50	μA
Input Leakage Current	I_{IL}				+/-1	μA

⁶ All Min/Max limits are guaranteed by Winbond via electrical testing or characterization. Not all specifications are 100% tested.

⁷ Typical values are $T = 25^\circ C$ and $V_{CC} = 3.0V$, timing measured at 50% levels.

⁸ V_{CCA} and V_{CCD} summed together.

Table 21. Speaker Driver Specifications.

PARAMETER	SYMBOL	TEST CONDITIONS	SPEC			UNIT
			MIN.	TYP.	MAX.	
SP+/- Output Voltage (HIGH Gain Setting)	V_{SPHG}	Peak-to-Peak, differential load = 150Ω			3.6	V
SP+/- Output Load Imp. (LOW Gain)	R_{SPLG}		8			Ω
SP+/- Output Load Imp. (HIGH Gain)	R_{SPHG}		70	150		Ω
SP+/- Output Load Cap.	\overline{CS}_P				100	pF
SP+/- Output Bias Voltage (Analog Ground)	V_{SPAG}			1.2		V_{DC}
Speaker Output DC Offset	V_{SPDCO}	With AUXIN to Speaker, AUXIN AC coupled to V_{SSA}			100	mV_{DC}
Power Supply Rejection Ratio	PSRR	Measured with a 1 kHz, 100 ma sine wave input at V_{CC} and V_{CC} pins		-55		dB
Frequency Response (300-3400 Hz)	F_R	With 0TLP input to AUX IN, 6 dB setting ⁽¹²⁾	-0.25		+0.25	dB
Power Output (LOW Gain Setting)	P_{UTLOG}	Differential load at 8Ω	23.5			mW_{RMS}

Table 22. AUXOUT Parameters.

PARAMETER	SYMBOL	TEST CONDITIONS	SPEC			UNIT
			MIN.	TYP.	MAX.	
AUXOUT – Maximum Output Swing	V_{ANAIUT}	5k Ω Load (AC Coupled)			1.0	V
Minimum Load Impedance	R_L		5			k Ω
Maximum Load Capacitance	C_L				100	pF
AUXOUT	V_{BIAS}			1.2		VDC

Table 23. Volume Control Parameters.

PARAMETER	SYMBOL	TEST CONDITIONS	SPEC			UNIT
			MIN.	TYP.	MAX.	
Output Gain	A_{OUT}	8 steps of 4 dB, referenced to output		-28 to 0		dB
Absolute Gain		AUXIN 1.0 kHz OTLP, 6 dB gain setting measured differentially at SP+/-	-0.5		+0.5	dB



11. TYPICAL APPLICATION CIRCUIT

The following schematic diagrams are extracted from the WTS-ES701 evaluation board schematic.

The evaluation system includes the following basic clusters:

WTS701 processor cluster working with 3.3V, including an 8-ohm speaker, SPI connector to the host PC via the PC parallel port.

For more information about the evaluation system, please refer to the WTS-ES701 User's Guide.

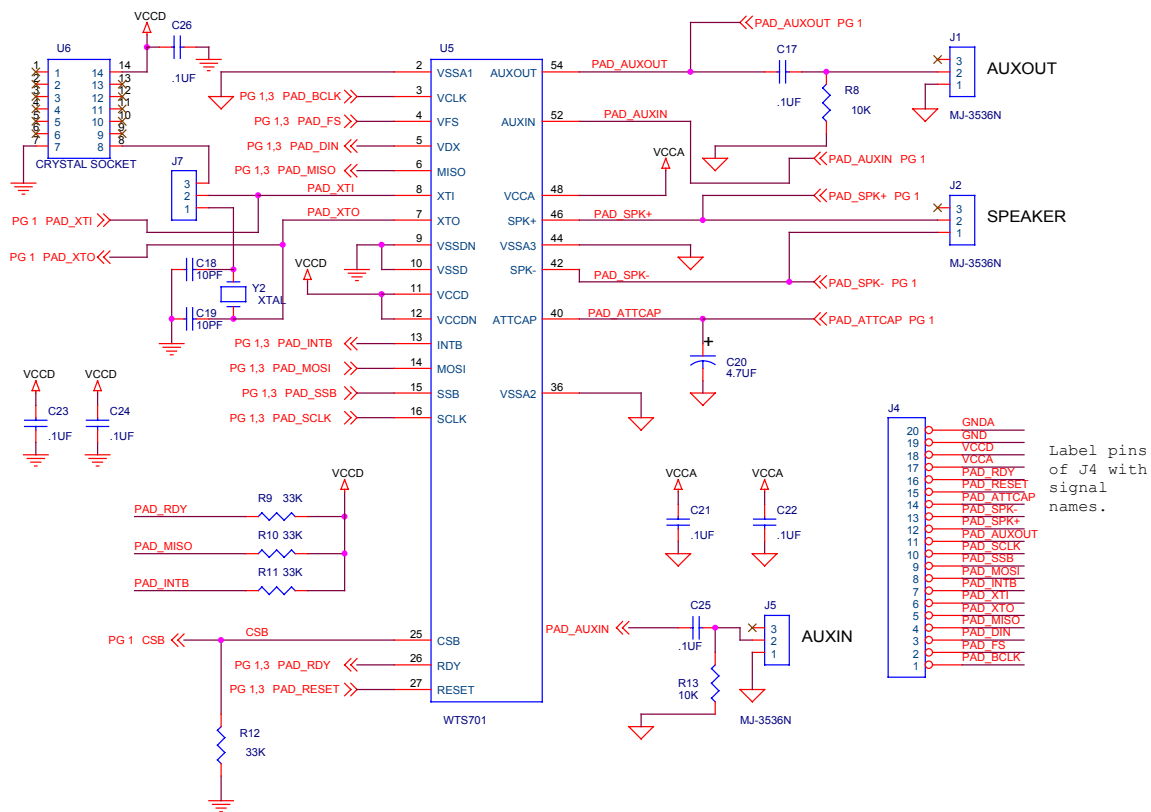

12. PACKAGE DRAWING AND DIMENSIONS

56 L TSOP(I) (14X20 MM)

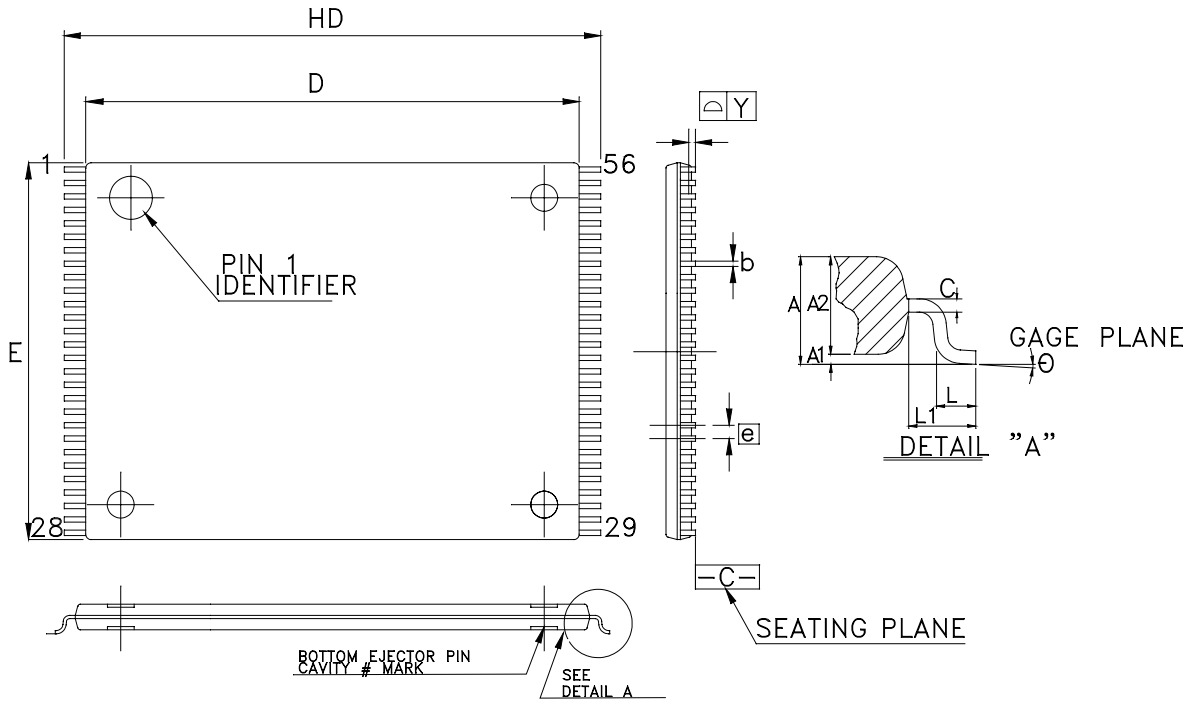

Symbol	Dimension in mm			Dimension in inch		
	Min	Nom	Max	Min	Nom	Max
A	—	—	1.2	—	—	0.047
A1	0.05	—	0.15	0.002	—	0.006
A2	0.95	1.00	1.05	0.037	0.039	0.041
b	0.17	0.22	0.27	0.007	0.009	0.011
c	0.10	—	0.21	0.004	—	0.008
HD	20.00 BSC			0.787 BSC		
D	18.40 BSC			0.724 BSC		
E	14.00 BSC			0.551 BSC		
L	0.50	0.60	0.70	0.020	0.024	0.028
L1	0.80 REF			0.031 REF		
e	0.5 BSC			0.020 BSC		
θ	0°	3°	5°	0°	3°	5°
Y	—	—	0.10	—	—	0.004



13. ORDERING INFORMATION

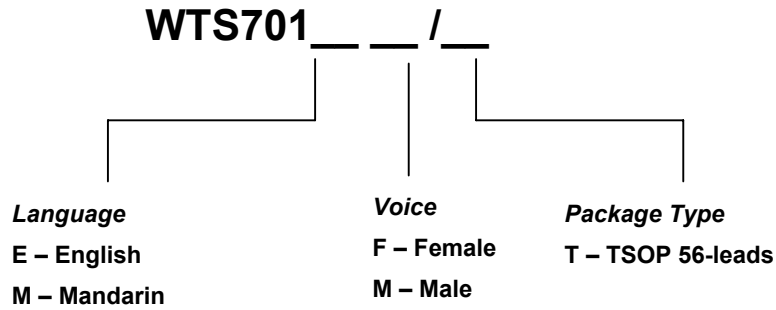

For the latest product information, access Winbond's worldwide website at <http://www.winbond-usa.com>



14. VERSION HISTORY

VERSION	DATE	PAGE	DESCRIPTION
3.07	Apr. 2002	1-73	Initial issue
3.08	Jun. 2002	1-73	Improved package drawing, added illegal commands description, modified part number format
3.09	May 2003	all	Add crystal spec., description of buffer length limit & undefined characters, consonant phoneme characters (P & Q), ^U3 and ^Q control characters.

The contents of this document are provided only as a guide for the applications of Winbond products. Winbond makes no representation or warranties with respect to the accuracy or completeness of the contents of this publication and reserves the right to discontinue or make changes to specifications and product descriptions at any time without notice. No license, whether express or implied, to any intellectual property or other right of Winbond or others is granted by this publication. Except as set forth in Winbond's Standard Terms and Conditions of Sale, Winbond assumes no liability whatsoever and disclaims any express or implied warranty of merchantability, fitness for a particular purpose or infringement of any Intellectual property.

Winbond products are not designed, intended, authorized or warranted for use as components in systems or equipments intended for surgical implantation, atomic energy control instruments, airplane or spaceship instruments, transportation instruments, traffic signal instruments, combustion control instruments, or for other applications intended to support or sustain life. Further, Winbond products are not intended for applications wherein failure of Winbond products could result or lead to a situation wherein personal injury, death or severe property or environmental injury could occur.



Headquarters

No. 4, Creation Rd. III
Science-Based Industrial Park,
Hsinchu, Taiwan
TEL: 886-3-5770066
FAX: 886-3-5665577
<http://www.winbond.com.tw>

Winbond Electronics Corporation America

2727 North First Street, San Jose,
CA 95134, U.S.A..
TEL: 1-408-9436666
FAX: 1-408-5441798
<http://www.winbond-usa.com>

Winbond Electronics (Shanghai) Ltd.

27F, 299 Yan An W. Rd. Shanghai,
200336 China
TEL: 86-21-62365999
FAX: 86-21-62356998

Taipei Office

9F, No. 480, Pueiguang Rd
Neihu District,
Taipei, 114, Taiwan
TEL: 886-2-81777168
FAX: 886-287153579

Winbond Electronics Corporation Japan

7F Daini-ueno BLDG, 3-7-18
Shinyokohama Kohoky-ku,
Yokohama, 222-0033
TEL: 81-45-4781881
FAX: 81-45-4781800

Winbond Electronics (H.K.) Ltd.

Unit 9-15, 22F, Millennium City,
No. 378 Kwun Tong Rd.,
Kowloon, Hong Kong
TEL: 852-27513100
FAX: 852-27552064

Please note that all data and specifications are subject to change without notice.
All the trademarks of products and companies mentioned in this datasheet belong to their respective owners.
This product incorporates SuperFlash® technology licensed from SST.

Publication Release Date: May 2003

Revision 3.09