

## 100BASE-FX Spring-Latch SGMII SFP Transceiver

(For 2km transmission with MCU version)

### Members of Flexon™ Family

- ◆ Compatible with FCC 47 CFR Part 15, Class B
- ◆ Compatible with FDA 21 CFR 1040.10 and 1040.11, Class I
- ◆ Compatible with Telcordia GR-468-CORE
- ◆ RoHS compliance



### Features

- ◆ Build-in PHY supporting SGMII Interface
- ◆ Build-in high performance MCU supporting easier configuration
- ◆ Support more link status monitor, such as CRC error counter and Far End Fault Indication (FEFI)
- ◆ 100BASE-FX operation
- ◆ 1310nm FP laser and PIN photo-detector
- ◆ 2km transmission with MMF
- ◆ Standard serial ID information Compatible with SFP MSA
- ◆ SFP MSA package with duplex LC connector
- ◆ With Spring-Latch for high density application
- ◆ Very low EMI and excellent ESD protection
- ◆ +3.3V single power supply
- ◆ Operating case temperature: -40 to +85°C

### Applications

- ◆ Switch to Switch interface
- ◆ Switched backplane applications
- ◆ Router/Server interface
- ◆ Other optical transmission systems

### Standard

- ◆ Compatible with SFP MSA
- ◆ Compatible with IEEE 802.3-2002

### Description

Fiberxon FTM-3401C-SL2iCG is designed for 100BASE-FX applications, supporting distance of 2km on MMF with build-in PHY device supporting SGMII interface.

The optical output can be disabled by a TTL logic high-level input of Tx Disable, and the system also can disable the module via I2C. Tx Fault is provided to indicate that degradation of the laser. Loss of signal (LOS) output is provided to indicate the loss of an input optical signal of receiver or the link status with partner. The system can also get the LOS(or Link)/Disable/Fault information via I2C register access.

The standard serial ID information Compatible with SFP MSA describes the transceiver's capabilities, standard interfaces, manufacturer and other information. The host equipment can access this information via the 2-wire serial CMOS EEPROM protocol. For further information, please refer to SFP Multi-Source Agreement (MSA).

Building-in high performance MCU in this module, Host can more easily configure all functions of FTM-3401C-SL2iCG.

## Regulatory Compliance

The transceivers have been tested according to American and European product safety and electromagnetic compatibility regulations (See Table 1). For further information regarding regulatory certification, please refer to Flexon™ regulatory specification and safety guidelines, or contact with Fiberxon, Inc. America sales office listed at the end of the documentation.

**Table 1 - Regulatory Compliance**

Feature	Standard	Performance
Electrostatic Discharge (ESD) to the Electrical Pins	MIL-STD-883E Method 3015.7	Class 1(>500 V)
Electrostatic Discharge (ESD) to the Duplex LC Receptacle	IEC 61000-4-2 GR-1089-CORE	Compatible with standards
Electromagnetic Interference (EMI)	FCC Part 15 Class B EN55022 Class B (CISPR 22B) VCCI Class B	Compatible with standards
Immunity	IEC 61000-4-3	Compatible with standards
Laser Eye Safety	FDA 21CFR 1040.10 and 1040.11 EN60950, EN (IEC) 60825-1,2	Compatible with Class I laser product.
Component Recognition	UL and CSA	Compatible with standards
RoHS	2002/95/EC 4.1&4.2 2005/747/EC	Compliant with standards <sup>note</sup>

Note:

In light of item 5 in Annex of 2002/95/EC, "Pb in the glass of cathode ray tubes, electronic components and fluorescent tubes." and item 13 in Annex of 2005/747/EC, "Lead and cadmium in optical and filter glass.", the two exemptions are being concerned for Fiberxon's transceivers, because Fiberxon's transceivers use glass, which may contain Pb, for components such as lenses, windows, isolators, and other electronic components.

## Absolute Maximum Ratings

Stress in excess of the maximum absolute ratings can cause permanent damage to the module.

**Table 2 - Absolute Maximum Ratings**

Parameter	Symbol	Min.	Max.	Unit
Storage Temperature	T <sub>S</sub>	-40	+85	°C
Supply Voltage	V <sub>CC</sub>	-0.5	3.6	V
Operating Relative Humidity	-	5	95	%
Power consumption			1.2	W

## Recommended Operating Conditions

**Table 3- Recommended Operating Conditions**

Parameter	Symbol	Min.	Typical	Max.	Unit	Notes
Operating Case Temperature	T <sub>C</sub>	-40		+85	°C	

Power Supply Voltage	$V_{CC}$	3.10	3.30	3.50	V	
Power Supply Current	$I_{CC}$			350	mA	1
Date Rate			125		Mbps	

Note 1: The max. power supply current after module work stable.

## Optical and Electrical Characteristics

Table 4 - Optical and Electrical Characteristics

Parameter	Symbol	Min.	Typical	Max.	Unit	Notes
<b>Transmitter</b>						
Centre Wavelength	$\lambda_C$	1270	1310	1355	nm	
Average Output Power	$P_{Out}$	-20		-14	dBm	2
$P_{Out}@TX$ Disable Asserted	$P_{Out}$			-45	dBm	2
Spectral Width (RMS)	$\sigma$			7.7	nm	
Extinction Ratio	EX	9			dB	
Rise/Fall Time (20%~80%)	$t_r/t_f$			3	ns	3
Output Optical Eye	Compatible with IEEE 802.3-2002					4
Data Input Swing Differential (SGMII Series interface)	$V_{IN}$	200		2100	mV	5
Input Differential Impedance	$Z_{IN}$	80	100	120	$\Omega$	
TX Disable	Disable	2.0		$V_{CC}$	V	
	Enable	$V_{EE}$		$V_{EE}+0.8$		
TX Fault	Fault	2.0		$V_{CC}$	V	
	Normal	$V_{EE}$		$V_{EE}+0.5$		
<b>Receiver</b>						
Centre Wavelength	$\lambda_C$	1260	1310	1570	nm	
Receiver Sensitivity				-31.5	dBm	6
Receiver Overload		-8			dBm	6
Return Loss		12			dB	
LOS De-Assert				-32.5	dBm	
LOS Assert		-45			dBm	
LOS Hysteresis		0.5		4.5	dB	
Total Jitter (SGMII Series Interface)	$T_J$			0.43	UI	
Data Output Swing Differential (SGMII Series Interface)	$V_{OUT}$	370		2000	mV	5
LOS	High		2.0	$V_{CC}+0.3$	V	
	Low		$V_{EE}$	$V_{EE}+0.5$		

Notes:

- The optical power is launched into MMF 62.5/125 $\mu$ m.
- Unfiltered, measured with 4B/5B code for 125Mbps.
- Measured with 4B/5B code for 125Mbps.
- PECL logic, internally AC coupled.
- Measured with 4B/5B code for 125Mbps, worst-case extinction ratio,  $BER \leq 1 \times 10^{-10}$ .

## EEPROM Information

The SFP MSA defines a 256-byte memory map in EEPROM describing the transceiver's capabilities, standard interfaces, manufacturer, and other information, which is accessible over a 2-wire serial interface at the 8-bit address 1010000X (A0h). For the memory contents, please refer to Table 5.

**Table 5 - EEPROM Serial ID Memory Contents (A0h)**

Addr.	Field Size (Bytes)	Name of Field	Hex	Description
0	1	Identifier	03	SFP
1	1	Ext. Identifier	04	MOD4
2	1	Connector	07	LC
3—10	8	Transceiver	00 00 00 20 00 00 00 00	Transmitter Code
11	1	Encoding	02	4B5B
12	1	BR, nominal	01	100Mbps
13	1	Reserved	00	
14	1	Length (9um)-km	00	
15	1	Length (9um)	00	
16	1	Length (50um)	C8	2km
17	1	Length (62.5um)	C8	2km
18	1	Length (copper)	00	
19	1	Reserved	00	
20—35	16	Vendor name	46 49 42 45 52 58 4F 4E 20 49 4E 43 2E 20 20 20	"FIBERXON INC." (ASC II)
36	1	Reserved	00	
37—39	3	Vendor OUI	00 00 00	
40—55	16	Vendor PN	46 54 4D 2D 33 34 30 31 43 2D 53 4C 32 69 43 47	"FTM-3401C-SL2ICG" (ASC II)
56—59	4	Vendor rev	xx xx xx xx	ASC II ("31 30 20 20" means 1.0 revision)
60—61	2	Wavelength	05 1E	1310nm
62	1	Reserved	00	
63	1	CC BASE	xx	Check sum of bytes 0 - 62
64—65	2	Options	00 1A	LOS, TX_FAULT and TX_DISABLE
66	1	BR, max	00	
67	1	BR, min	00	
68—83	16	Vendor SN	xx xx xx xx xx xx xx xx xx xx xx xx xx xx xx xx	ASC II
84—91	8	Vendor date code	xx xx xx xx xx xx 20 20	Year(2 bytes), Month(2 bytes), Day (2 bytes)
92—94	3	Reserved	00 00 00	
95	1	CC_EXT	xx	Check sum of bytes 64 - 94
96—154	58	Vendor specific		
155	1	Reserved		Read only
156-247		Vendor specific		
248	1	Status		Read only

249	1	CFG0		Work mode configuration
250	1	CFG1		Work mode configuration
251	1	CFG2		Work mode configuration
252	1	Status		Module status indication
253	1	Reserved		Read only
254	1	PSWH		Password entry
255	1	PSWL		Password entry

Note: The “xx” byte should be filled in according to practical case. For more information, please refer to the related document of SFP Multi-Source Agreement (MSA) and application note of FTM-3401C-SL2iCG.

### Easier Configuration

Designing-in a high performance MCU in FTM-3401C-SL2iCG, host can configure Fiberxon’s SGMII series product easily.

For FTM-3401C-SL2iCG, host only need access few registers of A0H via I2C to configure SGMII series module, such as speed-selection, Auto-negotiation, LOS/Link detection, TX disable, FEFI and CRC error counter function support. Host can get inner status via access specific register of FTM-3401C-SL2iCG.

The operation data rate can be configured via hardware pin and I2C bus independently.

For more detailed information, please refer to application note of FTM-3401C-SL2iCG.

### Recommended Host Board Power Supply Circuit

Figure 1 shows the recommended host board power supply circuit.

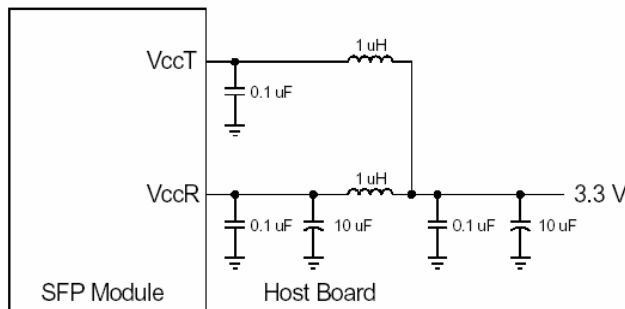

Figure 1, Recommended Host Board Power Supply Circuit

### Recommended Interface Circuit

Figure 2 shows the recommended interface circuit.

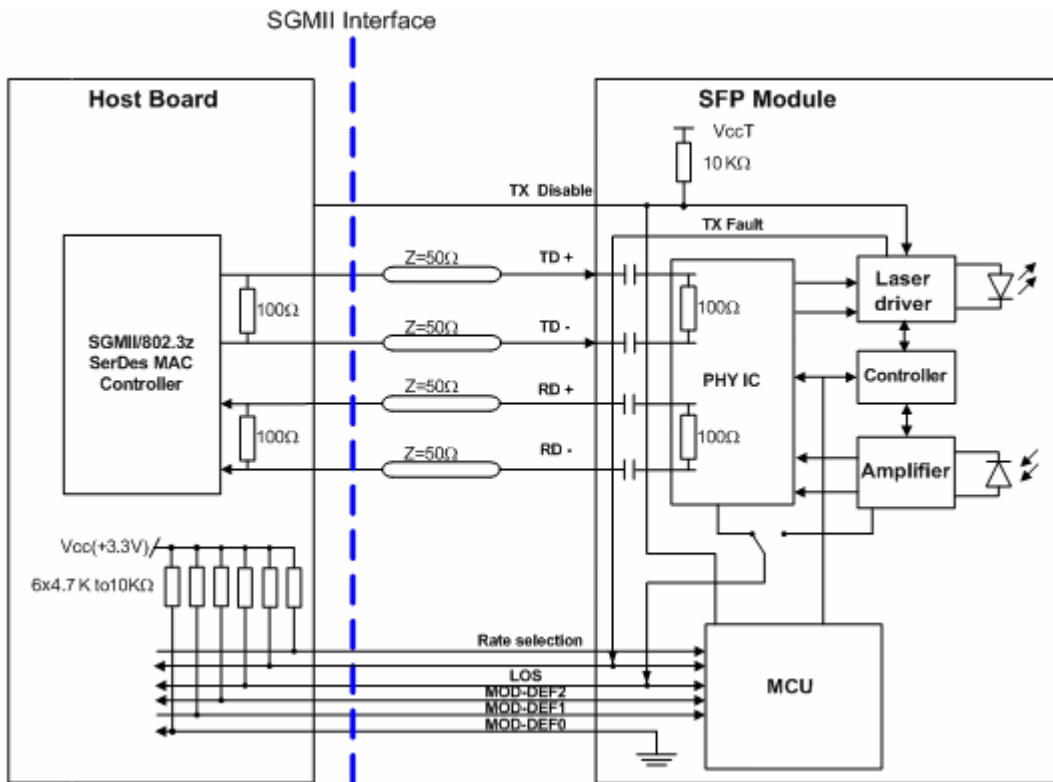

Figure 2, Recommended Interface Circuit

**Pin Definitions**

Figure 3 below shows the pin numbering of SFP electrical interface. The pin functions are described in Table 6 with some accompanying notes.

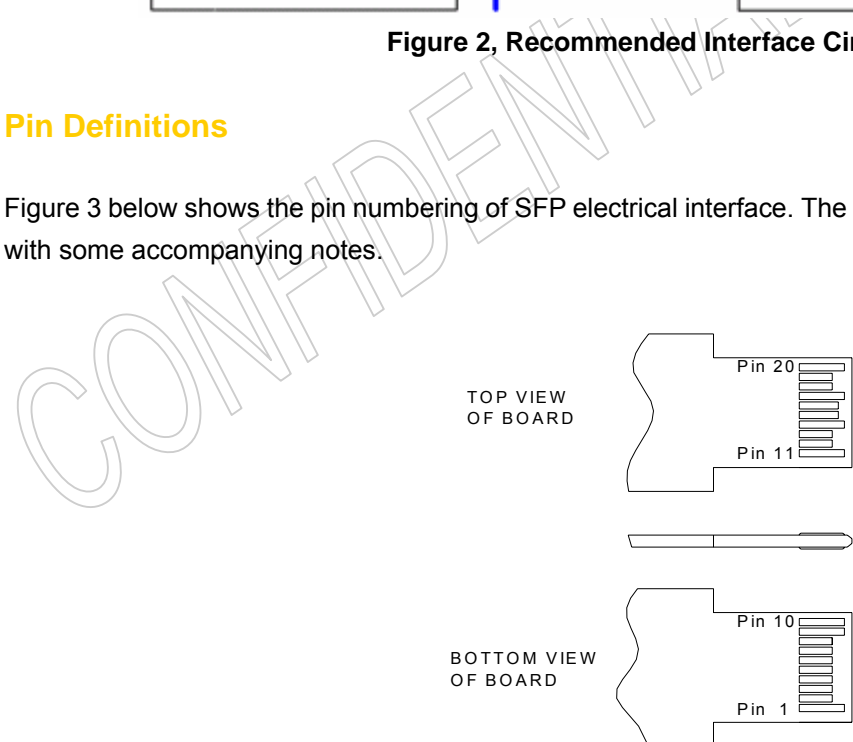

Figure 3, Pin View

Table 6– Pin Function Definitions

Pin No.	Name	Function	Plug Seq.	Notes
1	VeeT	Transmitter Ground	1	
2	TX Fault	Transmitter Fault Indication	3	Note 1
3	TX Disable	Transmitter Disable	3	Note 2
4	MOD-DEF2	Module Definition 2	3	Note 3

5	MOD-DEF1	Module Definition 1	3	Note 3
6	MOD-DEF0	Module Definition 0	3	Note 3
7	Rate Select	Not Connected	3	
8	LOS	Loss of Signal	3	Note 4
9	VeeR	Receiver Ground	1	
10	VeeR	Receiver Ground	1	
11	VeeR	Receiver Ground	1	
12	RD-	Inv. Received Data Out	3	Note 5
13	RD+	Received Data Out	3	Note 5
14	VeeR	Receiver Ground	1	
15	VccR	Receiver Power	2	
16	VccT	Transmitter Power	2	
17	VeeT	Transmitter Ground	1	
18	TD+	Transmit Data In	3	Note 6
19	TD-	Inv. Transmit Data In	3	Note 6
20	VeeT	Transmitter Ground	1	

**Notes:**

- TX Fault is an open collector output, which should be pulled up with a 4.7k~10kΩ resistor on the host board to a voltage between 2.0V and Vcc+0.3V. Logic 0 indicates normal operation; logic 1 indicates a laser fault of some kind. In the low state, the output will be pulled to less than 0.8V.
- TX Disable is an input that is used to shut down the transmitter optical output. It is pulled up within the module with a 4.7k~10kΩ resistor. Its states are:  
 Low (0~0.8V): Transmitter on  
 (>0.8V, <2.0V): Undefined  
 High (2.0~3.465V): Transmitter Disabled  
 Open: Transmitter Disabled
- MOD-DEF 0,1,2 are the module definition pins. They should be pulled up with a 4.7k~10kΩ resistor on the host board. The pull-up voltage shall be VccT or VccR.  
 MOD-DEF 0 is grounded by the module to indicate that the module is present  
 MOD-DEF 1 is the clock line of two wire serial interface for serial ID  
 MOD-DEF 2 is the data line of two wire serial interface for serial ID
- LOS is an open collector output, which should be pulled up with a 4.7k~10kΩ resistor on the host board to a voltage between 2.0V and Vcc+0.3V. Logic 0 indicates normal operation; logic 1 indicates loss of signal or link down with partner. In the low state, the output will be pulled to less than 0.8V.
- These are the differential receiver output. They are internally AC-coupled 100Ω differential lines which should be terminated with 100Ω (differential) at the user SGMII.
- These are the differential transmitter inputs. They are AC-coupled, differential lines with 100Ω differential termination inside the module.

## Mechanical Design Diagram

The mechanical design diagram is shown in Figure 4.

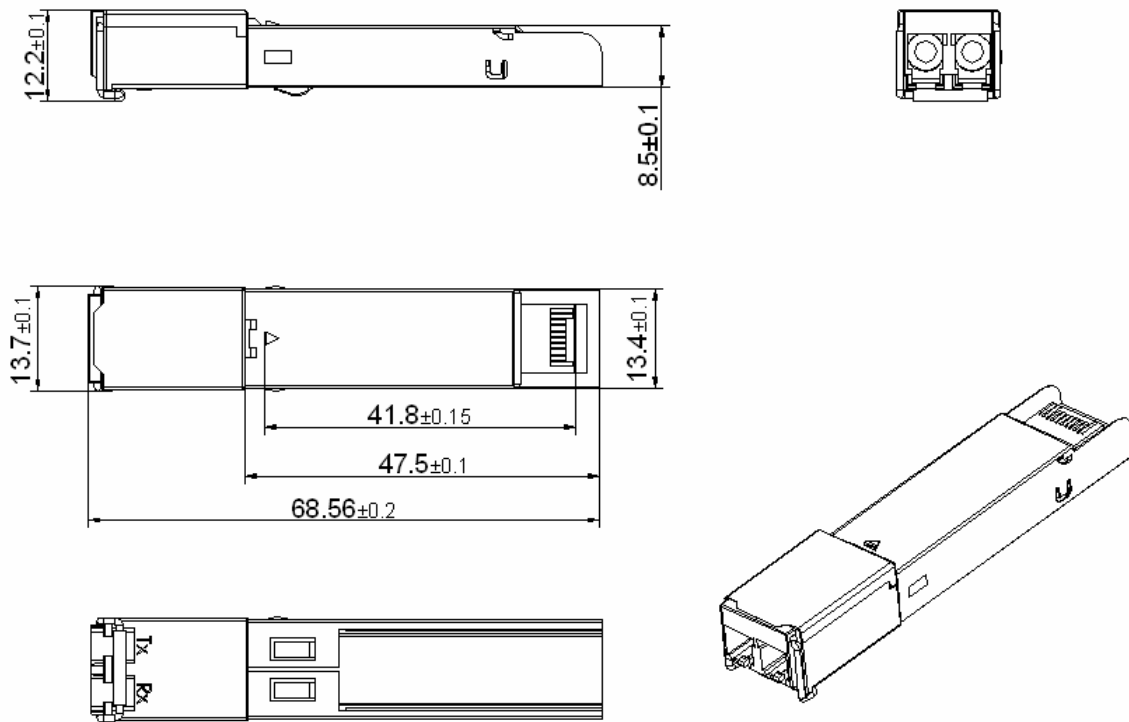
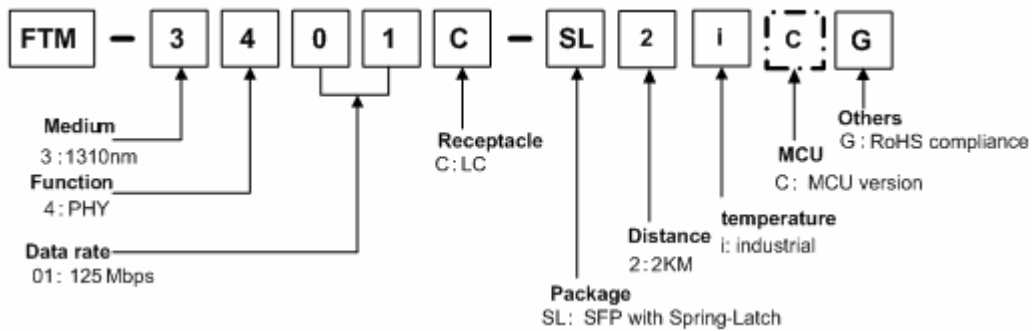

Figure 4, Mechanical Design Diagram of the SFP with Spring-Latch

Ordering information



Product part Number	Media	Data Rate(Mbps)	Transmission Distance(km)	Note	temperature
FTM-3401C-SL2iCG	MMF	125	2	MCU version, Industrial	-40~+85°C

Related SGMII SFP Products

Product part Number	Media	Data Rate(Mbps)	Transmission Distance	Note	temperature
FTM-C012R-LCG	Cat. 5 Copper	10/100/1000	100m		0~+70°C

FTM-3401C-SL2CG	MMF	125	2km	MCU version	0~+70°C
FTM-3401C-SL10CG	SMF	125	10km	MCU version	0~+70°C
FTM-3413C-SLCG	SMF	125/1250	10km	MCU version	0~+70°C
FTM-3413C-SL05CG	MMF	125/1250	2km/550m	MCU version	0~+70°C
FTM-3401C-SL10iCG	SMF	125	10km	MCU version	-40~+85°C
FTM-3413C-SLiCG	SMF	125/1250	10km	MCU version	-40~+85°C
FTM-3413C-SL05iCG	MMF	125/1250	2km/550m	MCU version	-40~+85°C

## Related Documents

For further information, please refer to the following documents:

- *Fiberxon Spring-Latch SFP Installation Guide*
- *Fiberxon SFP Application Notes*
- *SFP Multi-Source Agreement (MSA)*

## Obtaining Document

You can visit our website:

<http://www.fiberxon.com>

Or contact with Fiberxon, Inc. America Sales Office listed at the end of documentation to get the latest documents.

## Revision History

Revision	Initiate	Review	Approve	Subject	Release Date
Rev 1a	Henry.Xiao	Tripper.Huang	Walker.We	Initial datasheet.	Feb. 5, 2007
Rev 1b	Univer.Yang	Armstrong.Tian	Tripper.Huang	Revise.	Sep. 11, 2007

**© Copyright Fiberxon Inc. 2007**

All Rights Reserved.

All information contained in this document is subject to change without notice. The products described in this document are NOT intended for use in implantation or other life support applications where malfunction may result in injury or death to persons.

The information contained in this document does not affect or change Fiberxon product specifications or warranties. Nothing in this document shall operate as an express or implied license or indemnity under the intellectual property rights of Fiberxon or third parties. All information contained in this document was obtained in specific environments, and is presented as an illustration. The results obtained in other operating environment may vary.

THE INFORMATION CONTAINED IN THIS DOCUMENT IS PROVIDED ON AN "AS IS" BASIS. In no event will Fiberxon be liable for damages arising directly from any use of the information contained in this document.

**Contact**

U.S.A. Headquarter:

5201 Great America Parkway, Suite 340

Santa Clara, CA 95054

U. S. A.

Tel: 408-562-6288

Fax: 408-562-6289

Or visit our website: <http://www.fiberxon.com>

CONFIDENTIAL LEVEL