

# LCD MODULE SPECIFICATION

**Products Name:APAX T14C2  
35.7CM(14.1 INCH) XGA(1024x768)  
262K COLOR TFT LCD MODULE  
5.0V**

- **Preliminary Specification**

**This technical specification is tentative and it will be changed without notice.**

**進金生實業股份有限公司**

**台北市內湖區瑞光路76巷39號4樓**

**Tel:02-87912868 Fax:02-87912869**

**Version. 1.0**

---

## CONTENTS

### REVISION HISTORY

### GENERAL DESCRIPTION

#### 1. ABSOLUTE MAXIMUM RATINGS

#### 2. ELECTRICAL SPECIFICATIONS

#### 3. INTERFACE SPECIFICATIONS

##### 3.1 THE PIN ASSIGNMENT OF TTL INTERFACE CONNECTOR

##### 3.2 INPUT SIGNAL TIMING SPECIFICATIONS

##### 3.3 COLOR DATA INPUT ASSIGNMENT

##### 3.4 POWER UP/DOWN SEQUENCE

#### 4. OPTICAL SPECIFICATIONS

#### 5. Reliability Test Item

#### 6. MECHNICAL DRAWINGS

#### 7. PRECAUTION

##### 7.1 ASSEMBLY AND HANDLING PRECAUTION

##### 7.2 SAFTY PRECAUTION

#### 8. PACKAGING

##### 8.1 PACKING SPECIFICATIONS

##### 8.2 PACKING METHOD

#### 9. INCOMING INSPECTION DAY

#### 10. DEFINITION OF SHIPPING LABEL ON MODULE

### REVISION HISTORY

VERSION	Date	DESCRIPTION
Ver 1.0	Sep.10'99	Issue Preliminary Specification.
Ver 2.0	Nov.11'99	<p><u>Page 6/25</u>            - To revise the MECHANICAL SPECIFICATIONS</p> <p><u>Page 7/25</u>            - To Change the ABSOLUTE MAXIMUM RATINGS of Humidity</p> <p><u>Page 8/25</u>            - To add Notes statement in ELECTRICAL SPECIFICATIONS</p> <p><u>Page 11/25</u>            - 3.2 INPUT SIGNAL TIMING SPECIFICATIONS is modified and added the values which is TBD in version 1.0.</p> <p><u>Page 12/25</u>            - To revise the Tvdb interval in INPUT SIGNAL TIMING DIAGRAM.</p> <p><u>Page 14/25</u>            - The illustration of POWER UP/DOWN SEQUENCE is modify.</p> <p><u>Page 15/25 ~ 18/25</u>            - To revise the OPTICAL SPECIFICATIONS and modify the Illustration of Notes.</p> <p><u>Page 21/25</u>            - Add the PRECAUTION statement.</p> <p><u>Page 22/25~24/25</u>            - Add the illustration of PACKAGING method</p>
Ver 2.1	Jan.31'00	<p>Issue Approval Specification.</p> <p><u>Page 6/25</u>            - Add BLOCK DIAGRAM            - Add " Gap, panel surface with metal frame" spec. in MECHANICAL SPECIFICATIONS.</p> <p><u>Page 7/25</u>            - Change the humidity condition in ABSOLUTE MAXIMUM RATINGS.            Old -&gt;Operation : 20% ~ 90% relative humidity            Non operation : 5% ~ 85% relative humidity            New -&gt;Operation : 20% ~ 95% relative humidity, Ta≤40°C            Storage: 5% ~ 95% relative humidity ,Ta≤40°C            - Add Min./Max. value for " Power Supply Current" in ELECTRICAL SPECIFICATIONS ( MODULE).            - Add Min./Max. value for " Power Consumption" in ELECTRICAL SPECIFICATIONS ( BACKLIGHT).</p>

**REVISION HISTORY ( Continuation)**

VERSION	Date	DESCRIPTION
Ver 2.1	Jan.31'00	<p><u>Page 11/25</u></p> <ul style="list-style-type: none"> <li>- The following notes are attachment on INPUT SIGNAL TIMING SPECIFICATIONS               <ol style="list-style-type: none"> <li>1.Data is latched at falling edge of DCLK in the spec. DCLK should appear during all blanking period.</li> <li>2.VSYNC and HSYNC are negative polarity in the spec.</li> <li>3.DE (Data Enable) should be positive polarity in the spec.</li> <li>4.HSYNC should appear during blanking period of frame cycle.</li> </ol> </li> </ul> <p><u>Page 15/25</u></p> <ul style="list-style-type: none"> <li>- Add Cross Talk specifications in OPTICAL SPECIFICTIONS</li> </ul> <p><u>Page 19/25</u></p> <ul style="list-style-type: none"> <li>- Add Note 9: Definition of Cross Talk(CT)</li> </ul> <p><u>Page 20/25</u></p> <ul style="list-style-type: none"> <li>- Add 5.Reliability Test Item</li> </ul> <p><u>Page 24/25</u></p> <ul style="list-style-type: none"> <li>- Add 9. INCOMING INSPECTION DAY</li> </ul>
Ver 2.2	Mar.1'00	<p><u>Page 7/25</u></p> <ul style="list-style-type: none"> <li>-To change the Lamp Voltage in 2. ELECTRICAL SPECIFICATIONS                Old : 640 (Typ.) ==&gt; New : 560(Min.)/630(Typ.)/700(Max.)</li> <li>-To change the Startup Volage in 2. ELECTRICAL SPECIFICATIONS                Old : 985(25°C)/1450(0°C) ==&gt; New : 1255(25°C)/1385(0°C)</li> </ul> <p><u>Page 8/25</u></p> <ul style="list-style-type: none"> <li>- To add the test pattern for Power Supply Current.</li> </ul> <p><u>Page 18/25</u></p> <ul style="list-style-type: none"> <li>- To update the illustration for Cross Talk Definition in Note 10.</li> </ul> <p><u>Page 20/25</u></p> <ul style="list-style-type: none"> <li>- To add the Criterion after Reliability Test Item.</li> </ul>
Ver 2.3	May.23'00	<p><u>Page 15/25</u></p> <ul style="list-style-type: none"> <li>- To revise Response Time                Old ==&gt; Tr =20(Typ.)/35(Max.) , Tf =30(Typ.)/45(Max.) ms                New==&gt; Tr =15(Typ.)/30(Max.) , Tf =35(Typ.)/50(Max.) ms</li> </ul> <p><u>Page 11/25</u></p> <ul style="list-style-type: none"> <li>- To revise "DATA" in 3.2 INPUT SIGNAL TIMING SPECIFICATIONS.                Old setup time: -(Min.)/7.0(Typ.); New setup time: 5.0(Min.)/-(Typ.)                Old hold time: -(Min.)/7.0(Typ.); New hold time: 6.0(Min.)/-(Typ.)</li> </ul>

**REVISION HISTORY ( Continuation)**

VERSION	Date	DESCRIPTION
		<p><u>Page 25/25</u>            - Add 10. Definition of Shipping Label on Module.</p> <p><u>Page 6/25</u>            - To change the depth specification            Old -&gt; 16.0 (Typ.) / 16.2( MAX.),            New -&gt; 17.0 (Typ.) /18.0( MAX.)</p> <p><u>Page 7/25</u>            - To change the color of lamp power cable.            Old -&gt; HV is White / LV is Black            New -&gt; HV is Pink / LV is White</p> <p><u>Page 12/25</u>            - To revise the DCLK/DATA/DE clock diagram.</p> <p><u>Page 15/25</u>            - To revise the Chromaticity specification.</p> <p><u>Attached Drawing</u>            - To revise the Attached Drawing .</p>

## GENERAL DESCRIPTION

### OVERVIEW

This product is a 14.1" TFT Liquid Crystal Display Module with a 2 lamps Backlight unit and 60 pins TTL interface. This module supports 1024 x 768 XGA mode and can display 262,144 colors. The inverter module for Backlight is not built in.

### BLOCK DIAGRAM

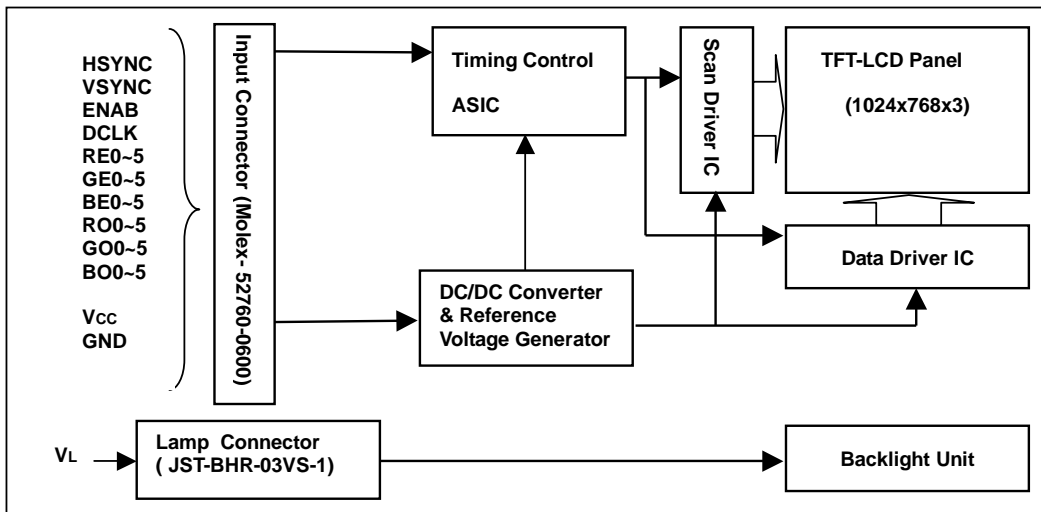

### APPLICATION

-TFT-LCD Monitor

### GENERAL SPECIFICATIONS

Item	Specifications	Unit
Screen Size	14.1 Diagonal	inch
Bezel opening area	289.8(W)x218.4(H)	mm
Effective display area	285.7(W)x214.3(H)	mm
Pixel number	1024 x R.G.Bx768	pixel
Pixel pitch	0.279(H)x0.279(V)	mm
Pixel Arrangement	R.G.B Vertical Stripe	-
Display Color	6 bits, 262,144	color
Transmissive mode	Normally white	-
Surface treatments	Hard coating(3H) and anti-glare	-

### MECHANICAL SPECIFICATIONS

ITEM		MIN.	TYP.	MAX.	Unit
Module size	Horizontal	329.5	330	330.5	mm
	Vertical	254.5	255	255.5	mm
	Depth	-	17.0	18.0	mm
Weight		-	1250	1300	g
Gap, panel surface with metal frame		-	-	0.5	mm

## 1. ABSOLUTE MAXIMUM RATINGS

Parameter	Symbol	Values		Unit	Remarks
		Min.	Max.		
Power supply voltage	VCC	-0.3	+6.0	V	Ta=25°C
Logic input voltage	VIN	-0.3	VCC+0.3	V	
Operating temperature	Top	0	+50	°C	Module surface*
Storage temperature	Tst	-20	+60	°C	-
Humidity	Operation	20%~95% relative humidity			Ta<=40°C
	Non operation	5%~95% relative humidity			Ta<=40°C

\*Measure at the active display area

## 2. ELECTRICAL SPECIFICATIONS

MODULE						
Parameter	Symbol	Value			Unit	Notes
		Min.	Typ.	Max.		
Power Supply Voltage	V <sub>CC</sub>	4.5	5.0	5.5	V	1
Power Supply Current	I <sub>CC</sub>	140	290	600	mA	
Ripple voltage	V <sub>RP</sub>	-	50	-	mV	
"H" level logical input voltage	V <sub>IH</sub>	2	-	V <sub>CC</sub>	V	
"L" level logical input voltage	V <sub>IL</sub>	V <sub>SS</sub>	-	1	V	

BACKLIGHT ( 2 Lamps)						Ta=25±2°C
Parameter	Symbol	Value			Unit	Notes
		Min.	Typ.	Max.		
Lamp Voltage	V <sub>L</sub>	560	630	700	V <sub>RMS</sub>	I <sub>L</sub> =6.0mA
Lamp Current	I <sub>L</sub>	1.0	6.0	8.0	mA	2
Startup Voltage	V <sub>S</sub>	-	-	1255 (25°C)	V <sub>RMS</sub>	3
		-	-	1385 (0°C)	V <sub>RMS</sub>	3
Operating Frequency	F <sub>L</sub>	30	50	70	KHz	4
Power Consumption	P <sub>L</sub>	6.8	7.6	8.4	W	5, I <sub>L</sub> =6.0mA
Lamp Life time	L <sub>BL</sub>	50000	-	-	Hrs	6

The connector information of Black light unit.

Pin	Symbol	Description	Remark
1	HV	Lamp power input	Pink
2	NC	No connect	-
3	LV	Ground	White

Connector Part No.: BHR-03VS-1 (JST)

User's connector Part No.: SM02 (8.0) B-BHS-1-TB (JST)

Note1: Operating Temperature range : 0 ~ 50 °C.

Power Supply Current specifications are tested by the following test pattern.

(a) Minimal value test pattern : White pattern

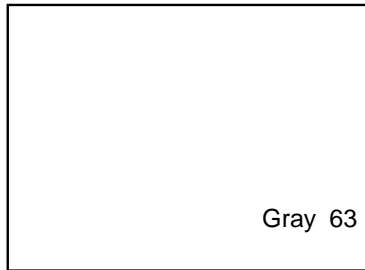

(b) Typical value test pattern : 64 gray scale pattern

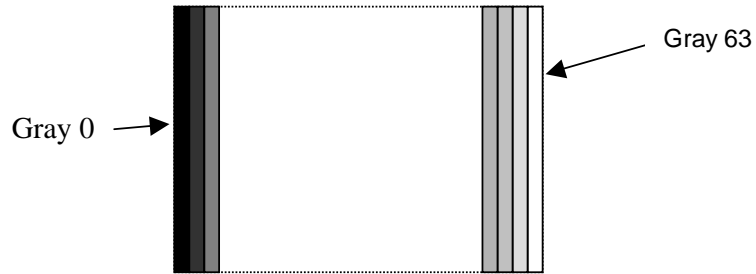

(c) Maximal value test pattern : Vertical 2 pixel white/black pattern

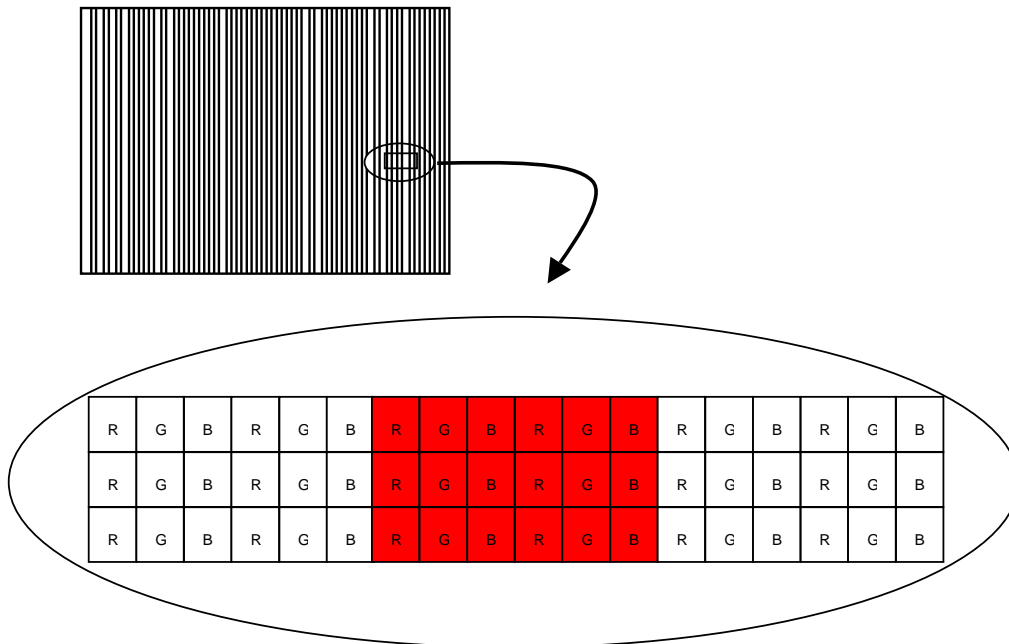



Note 2: Lamp current is measured by utilizing a current meter for high frequency as shown below:

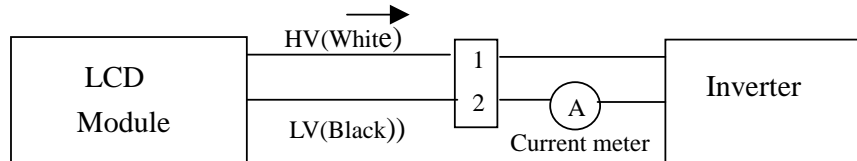

Note 3: The voltage shown above should be applied to the lamp for more than 1 second after startup. Otherwise the lamp may not be turned on. And the start voltage at 0°C is the condition that stabilizes in the lamp, and it is the value that guarantees the lighting of the lamp.

Note 4: The lamp frequency may produce interference with horizontal synchronous frequency from the display, and this may cause line flow on the display. In order to avoid interference the lamp frequency should be detached from the horizontal synchronous frequency and its harmonics as far as possible.

Note 5:  $P_L = I_L \times V_L \times 2$ .

Note 6: The lifetime (Hr) of a lamp can be defined as the time in which it continues to operate under the condition  $T_a = 25 \pm 2^\circ\text{C}$  and  $I_L = 6.0 \text{ mArms}$  until one of the following event occurs:

- (1) When the brightness becomes 50% or lower than its original,
- (2) When the effective ignition length becomes 80% or lower than its original value.  
(Effective ignition length is defined as an area that has less than 70% brightness compared to the brightness in the center point.)

Note 7: The waveform of the voltage output of inverter must be area-symmetric and the design of the inverter must have specifications for the modularized lamp. The performance of the backlight, such as lifetime or brightness, is greatly influenced by the characteristics of the DC-AC inverter for the lamp. All the parameters of an inverter should be designed with care so as not to produce too much current leakage from high-voltage output of the inverter. When designing or ordering the inverter, please make sure that a poor lighting caused by the mismatch of the backlight and the inverter (miss-lighting, flicker, etc.) never occurs. When the above situation is confirmed, the module should be operated in the same manners as it is installed in your instrument.

### 3. INTERFACE SPECIFICATIONS

#### 3.1 THE PIN ASSIGNMENT OF TTL INTERFACE CONNECTOR.

Pin No.	Symbol	I/O	Function	Pin No.	Symbol	I/O	Function
1	GND	-	Ground	31	GE1	I	Green even data 1
2	RO0	I	Red odd data 0	32	GE2	I	Green even data 2
3	RO1	I	Red odd data 1	33	GE3	I	Green even data 3
4	RO2	I	Red odd data 2	34	GE4	I	Green even data 4
5	RO3	I	Red odd data 3	35	GE5	I	Green even data 5
6	RO4	I	Red odd data 4	36	GND	-	Ground
7	RO5	I	Red odd data 5	37	BE0	I	Blue even data 0
8	GND	-	Ground	38	BE1	I	Blue even data 1
9	GO0	I	Green odd data 0	39	BE2	I	Blue even data 2
10	GO1	I	Green odd data 1	40	BE3	I	Blue even data 3
11	GO2	I	Green odd data 2	41	BE4	I	Blue even data 4
12	GO3	I	Green odd data 3	42	BE5	I	Blue even data 5
13	GO4	I	Green odd data 4	43	GND	-	Ground
14	GO5	I	Green odd data 5	44	VSYN	I	Vertical sync.
15	GND	-	Ground	45	HSYN	I	Horizontal sync.
16	BO0	I	Blue odd data 0	46	ENAB	I	Data enable signal
17	BO1	I	Blue odd data 1	47	GND	-	Ground
18	BO2	I	Blue odd data 2	48	GND	-	Ground
19	BO3	I	Blue odd data 3	49	DCLK	I	Dot clock signal
20	BO4	I	Blue odd data 4	50	GND	-	Ground
21	BO5	I	Blue odd data 5	51	GND	-	Ground
22	GND	-	Ground	52	NC	-	Must be floating
23	RE0	I	Red even data 0	53	NC	-	Must be floating
24	RE1	I	Red even data 1	54	GND	-	Ground
25	RE2	I	Red even data 2	55	GND	-	Ground
26	RE3	I	Red even data 3	56	GND	-	Ground
27	RE4	I	Red even data 4	57	VDD	-	+5V Power supply
28	RE5	I	Red even data 5	58	VDD	-	+5V Power supply
29	GND	-	Ground	59	VDD	-	+5V Power supply
30	GE0	I	Green even data 0	60	VDD	-	+5V Power supply

Connector Part No.: 52760-0600(Molex)

User's connector Part No: 53475-0600(Molex)

### 3.2 INPUT SIGNAL TIMING SPECIFICATIONS

The specifications of input signal timing are as the following table and timing diagram.

Signal	Parameter	Symbol	Min	Typ	Max	Unit	Remarks
DCLK	Pixel clock Frequency	fck	25	32.5	40	MHz	
	Pixel clock period	Tck	40	30	25	ns	
	Duty ratio (%Tch)	-	40	50	60	%	Tch/Tck
	Rise time	Trck	-	7.9	-	ns	
	Fall time	Tfck	-	7.3	-	ns	
DATA	Setup time	Tsd	5.0	-	-	ns	
	Hold time	Thd	6.0	-	-	ns	
	Rise time	Trd	-	8.9	-	ns	
	Fall time	Tfd	-	8.2	-	ns	
DE	Setup time	Tsde	4	5.8	-	ns	
	Hold time	Thde	4.5	6.2	-	ns	
VSYNC	Vertical Frequency	fv	50	60	75	Hz	
	Vertical period	Tvp	769	806	1000	Thp	
	Vertical display blank period	Tvdb	1	38	232	Thp	
	Vertical display active period	Tvda	768	768	768	Thp	
	Vertical sync. back porch	Vbp	0	29	199	Thp	
	Vertical sync. front porch	Vfp	0	3	199	Thp	
	Vertical sync. pulse width	Vpw	1	6	200	Thp	
HSYNC	Horizontal period	Thp	575	672	806	Tck	
	Horizontal display blank period	Thdb	63	160	294	Tck	
	Horizontal display active period	Thda	512	512	512	Tck	
	Horizontal sync. back porch	Hbp	52	53	281	Tck	
	Horizontal sync. front porch	Hfb	0	35	281	Tck	
	Horizontal sync. pulse width	Hpw	52	73	243	Tck	

- Note:**
- 1.Data is latched at falling edge of DCLK in the spec. DCLK should appear during all blanking period.
  2. VSYNC and HSYNC are negative polarity in the spec.
  - 3.DE (Data Enable) should be positive polarity in the spec.
  4. HSYNC should appear during blanking period of frame cycle.

**INPUT SIGNAL TIMING DIAGRAM**

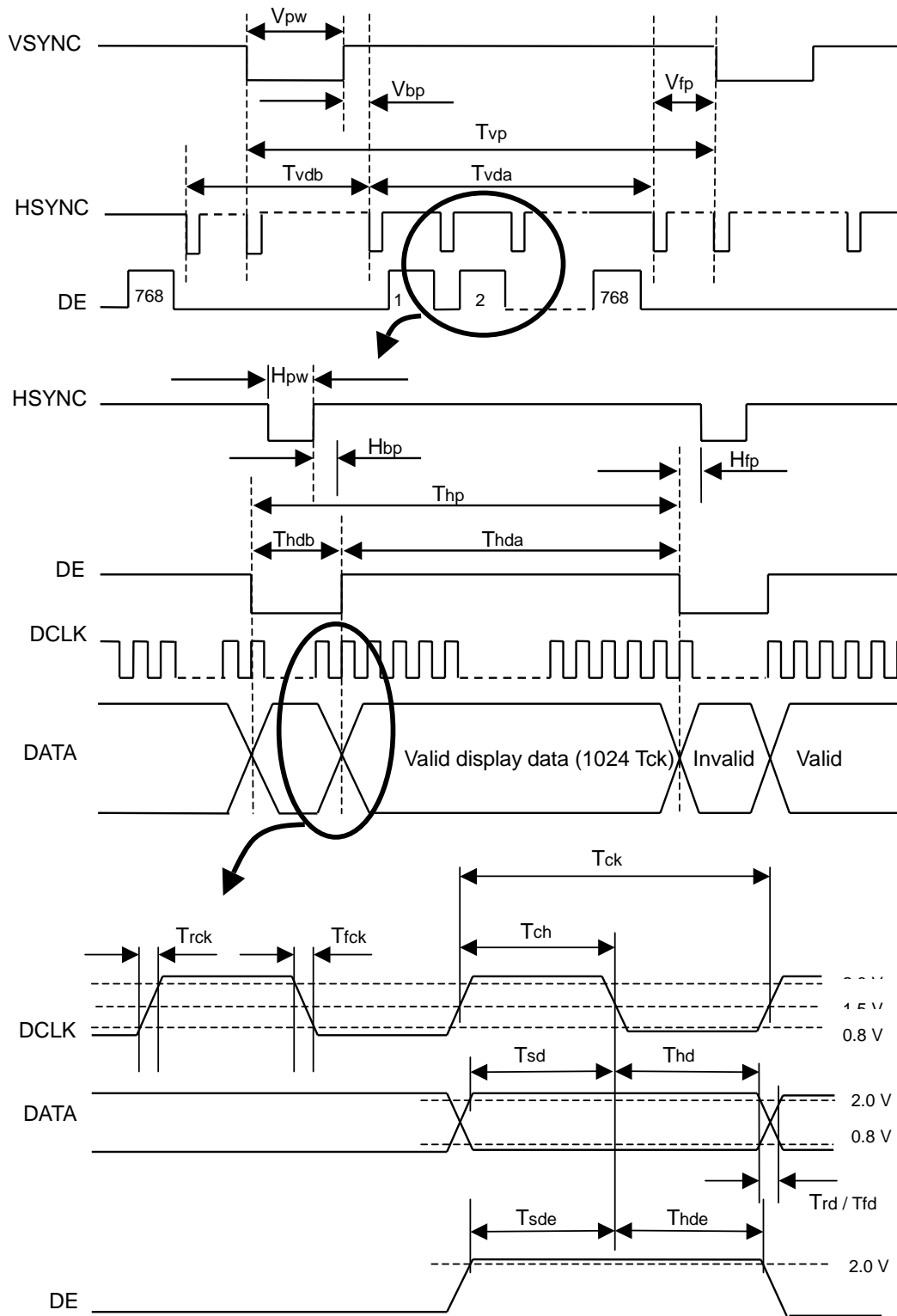

### 3.3 COLOR DATA INPUT ASSIGNMENT

Color		Data Signal																	
		Red						Green						Blue					
		RO5	RO4	RO3	RO2	RO1	RO0	GO5	GO4	GO3	GO2	GO1	GO0	BO5	BO4	BO3	BO2	BO1	BO0
Odd	Even	RE5	RE4	RE3	RE2	RE1	RE0	GE5	GE4	GE3	GE2	GE1	GE0	BE5	BE4	BE3	BE2	BE1	BE0
Basic Colors	Black	0	0	0	0	0	0	0	0	0	0	0	0	0	0	0	0	0	0
	Red	1	1	1	1	1	1	0	0	0	0	0	0	0	0	0	0	0	0
	Green	0	0	0	0	0	0	1	1	1	1	1	1	0	0	0	0	0	0
	Blue	0	0	0	0	0	0	0	0	0	0	0	0	1	1	1	1	1	1
	Cyan	0	0	0	0	0	0	1	1	1	1	1	1	1	1	1	1	1	1
	Magenta	1	1	1	1	1	1	0	0	0	0	0	0	1	1	1	1	1	1
	Yellow	1	1	1	1	1	1	1	1	1	1	1	1	0	0	0	0	0	0
	White	1	1	1	1	1	1	1	1	1	1	1	1	1	1	1	1	1	1
Gray Scale Of Red	Red(0) / Dark	0	0	0	0	0	0	0	0	0	0	0	0	0	0	0	0	0	0
	Red(1)	0	0	0	0	0	1	0	0	0	0	0	0	0	0	0	0	0	0
	Red(2)	0	0	0	0	1	0	0	0	0	0	0	0	0	0	0	0	0	0
	⋮	⋮	⋮	⋮	⋮	⋮	⋮	⋮	⋮	⋮	⋮	⋮	⋮	⋮	⋮	⋮	⋮	⋮	⋮
	⋮	⋮	⋮	⋮	⋮	⋮	⋮	⋮	⋮	⋮	⋮	⋮	⋮	⋮	⋮	⋮	⋮	⋮	⋮
	Red(61)	1	1	1	1	0	1	0	0	0	0	0	0	0	0	0	0	0	0
	Red(62)	1	1	1	1	1	0	0	0	0	0	0	0	0	0	0	0	0	0
	Red(63)	1	1	1	1	1	1	0	0	0	0	0	0	0	0	0	0	0	0
Gray Scale Of Green	Green(0) / Dark	0	0	0	0	0	0	0	0	0	0	0	0	0	0	0	0	0	0
	Green(1)	0	0	0	0	0	0	0	0	0	0	0	1	0	0	0	0	0	0
	Green(2)	0	0	0	0	0	0	0	0	0	0	1	0	0	0	0	0	0	0
	⋮	⋮	⋮	⋮	⋮	⋮	⋮	⋮	⋮	⋮	⋮	⋮	⋮	⋮	⋮	⋮	⋮	⋮	⋮
	⋮	⋮	⋮	⋮	⋮	⋮	⋮	⋮	⋮	⋮	⋮	⋮	⋮	⋮	⋮	⋮	⋮	⋮	⋮
	Green(61)	0	0	0	0	0	0	1	1	1	1	0	1	0	0	0	0	0	0
	Green(62)	0	0	0	0	0	0	1	1	1	1	1	0	0	0	0	0	0	0
	Green(63)	0	0	0	0	0	0	1	1	1	1	1	1	0	0	0	0	0	0
Gray Scale Of Blue	Blue(0) / Dark	0	0	0	0	0	0	0	0	0	0	0	0	0	0	0	0	0	0
	Blue(1)	0	0	0	0	0	0	0	0	0	0	0	0	0	0	0	0	0	1
	Blue(2)	0	0	0	0	0	0	0	0	0	0	0	0	0	0	0	0	0	1
	⋮	⋮	⋮	⋮	⋮	⋮	⋮	⋮	⋮	⋮	⋮	⋮	⋮	⋮	⋮	⋮	⋮	⋮	⋮
	⋮	⋮	⋮	⋮	⋮	⋮	⋮	⋮	⋮	⋮	⋮	⋮	⋮	⋮	⋮	⋮	⋮	⋮	⋮
	Blue(61)	0	0	0	0	0	0	0	0	0	0	0	0	1	1	1	1	0	1
	Blue(62)	0	0	0	0	0	0	0	0	0	0	0	0	1	1	1	1	1	0
	Blue(63)	0	0	0	0	0	0	0	0	0	0	0	0	1	1	1	1	1	1

### Correspondence between Data and Display Position

	S0001	S0002	S0003	S0004	S0005	S0006	S0007	S0008	-----	S3071	S3072
C001	RE	GE	BE	RO	GO	BO	RE	GE		GO	BO
	0001	0001	0001	0002	0002	0002	0003	0003		1024	1024
C768	RE	GE	BE	RO	GO	BO	RE	GE		GO	BO
	0001	0001	0001	0002	0002	0002	0003	0003		1024	1024

### 3.4 POWER UP/DOWN SEQUENCE

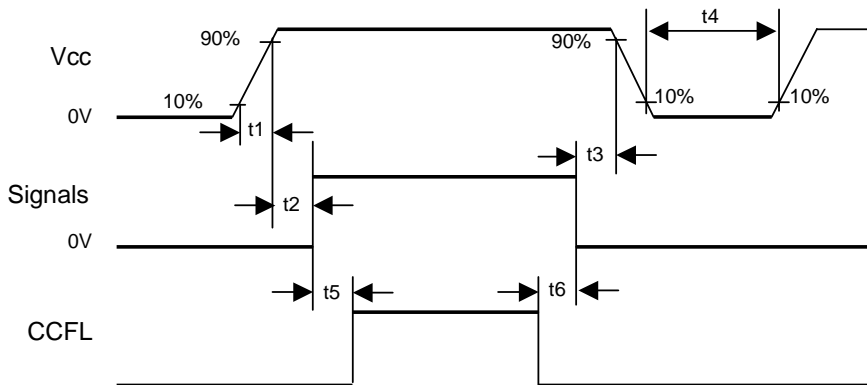

Timing Specifications:

$$0 \leq t1 \leq 10\text{mS}$$

$$0 \leq t2 \leq 50\text{mS}$$

$$0 \leq t3 \leq 50\text{mS}$$

$$t4 \geq 1\text{S}$$

$$t5 \geq 170\text{mS}$$

$$t6 \geq 200\text{mS (min.)}$$

- Notes:
1. Please avoid floating state of interface signal at invalid period.
  2. When the interface signal is invalid, be sure to pull down the power supply for LCD Vcc to 0V.

#### 4. OPTICAL SPECIFICATIONS

The following optical specifications shall be measured in a darkroom or equivalent state (ambient luminance  $\leq 1$  lux, and at room temperature). The measurement must be taken after backlight warming up for 20 minutes. The operation temperature is  $25^{\circ}\text{C} \pm 2^{\circ}\text{C}$ . The measurement method is shown in Note 1.

Parameter	Symbol	Condition	Min.	Typ.	Max.	Unit	Note
Central Luminance	L	Center, $I_L = 6.0\text{mA}$	170	200	-	$\text{Cd}/\text{m}^2$	1, 2, 4
Contrast ratio	CR	Center	150	200	-	-	1, 3
Viewing Angle	Horizontal	$\theta_{x+}$	40	45	50	degree	1, 4
		$\theta_{x-}$	40	45	50		
	Vertical	$\theta_{y+}$	10	15	20		
		$\theta_{y-}$	30	35	40		
	Horizontal	$\theta_{x+}$	58	63	68		
		$\theta_{x-}$	58	63	68		
	Vertical	$\theta_{y+}$	25	30	35		
		$\theta_{y-}$	45	55	60		
Average Luminance	$L_{ave}$	$I_L = 6.0\text{mA}$	150	180	-	$\text{Cd}/\text{m}^2$	1, 5
Brightness Uniformity	Buni	$\theta_x = \theta_y = 0^{\circ}$	1.0	1.4	1.6		1, 6
Response Time	Rising	$T_r$	-	15	30	ms	1, 7
	Falling	$T_f$	-	35	50	ms	
Chromaticity	$X_w$	Center $\theta_x = \theta_y = 0^{\circ}$	0.290	0.310	0.330	1, 8	
	$Y_w$		0.310	0.330	0.350		
	$X_R$		0.560	0.580	0.600		
	$Y_R$		0.308	0.328	0.348		
	$X_G$		0.280	0.300	0.320		
	$Y_G$		0.542	0.562	0.582		
	$X_B$		0.136	0.156	0.176		
	$Y_B$		0.097	0.117	0.137		
Cross Talk	CT	$\theta_x = \theta_y = 0^{\circ}$	-	-	4.0	%	1, 9

Note 1: The method of optical measurement:

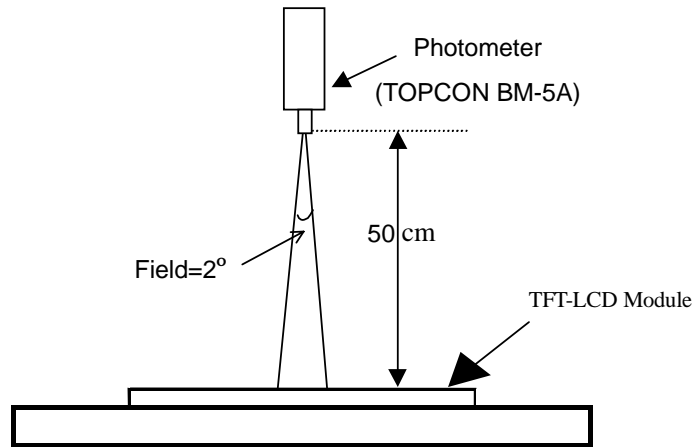

Note 2: Definition of Central Luminance (L):

Central Luminance must be measured at the central point of the LCD module and at the viewing angle of the  $\theta_x = \theta_y = 0^\circ$  (Note 4).

Note 3: Definition of Contrast Ratio (CR):

Contrast ratio measurement must be made at the viewing angle of the  $\theta_x = \theta_y = 0^\circ$  (Note 4) and at the central point of the LCD module. The Luminance (Note 2) shall be measured with all pixels in the viewing field set initially to be white state, then black state.

$$CR = \frac{\text{Luminance with all pixels in white state}}{\text{Luminance with all pixels in black state}}$$

Note 4: Definitions of Viewing Angle :

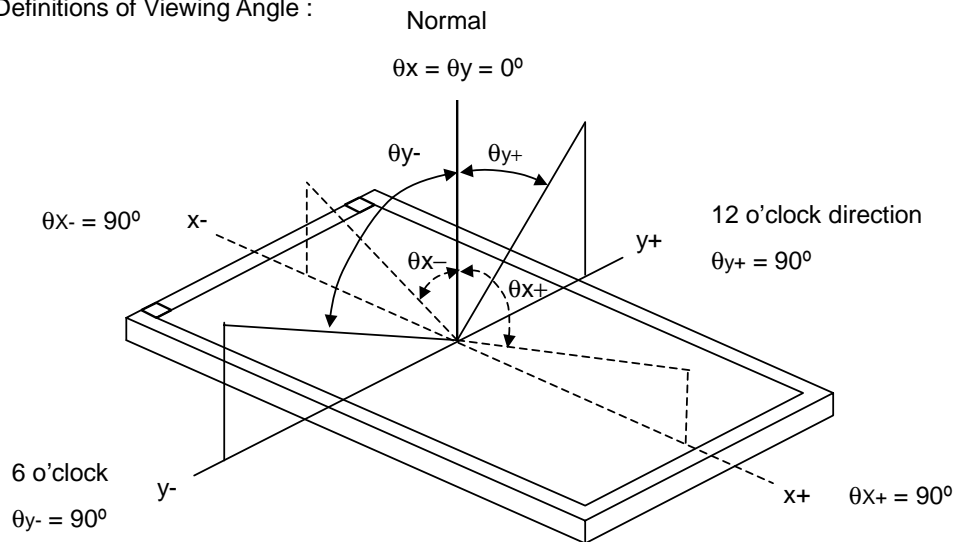



Note 5: Definition of Average Luminance:

The Average Luminance is defined as arithmetic mean value of five spots across the LCD surface at white state. The Luminance (Note 2) shall be measured with all pixels in the viewing field at white state. The measuring spots must be taken at the locations shown in the following figure, where  $a = b = 15\text{mm}$ .

$$L_{ave} = \frac{L_1 + L_2 + L_3 + L_4 + L_5}{5}$$

Luminance Measuring Points

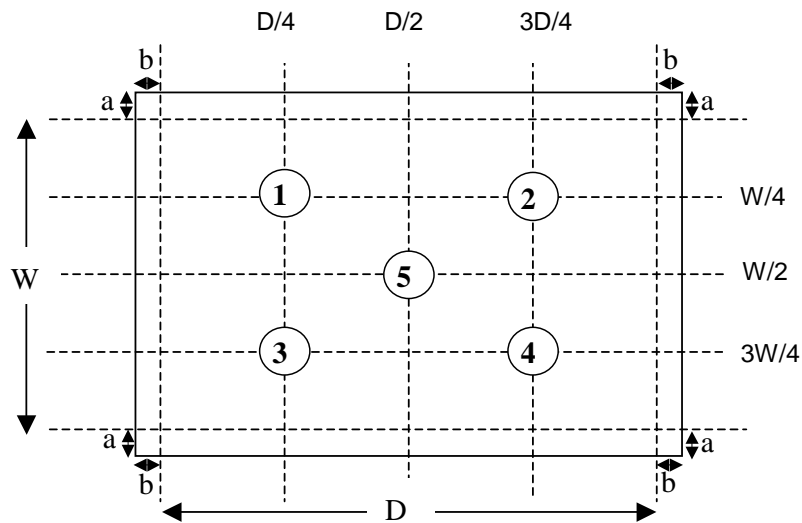

Note 6: Definition of Brightness Uniformity ( $B_{uni}$ ):

$$B_{uni} = \frac{\text{Maximum luminance of 5 points}}{\text{Minimum luminance of 5 points}}$$

Note 7: Definition of Response Time:

The Response Time is set initially by defining the “ Rising Time (Tr)” and the “ Falling Time (Tf)” respectively. Tr and Tf are defined as following figure.

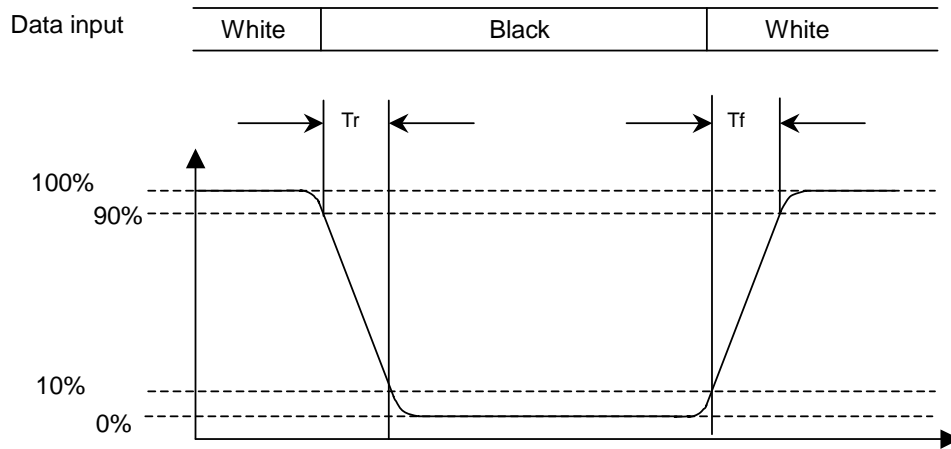

Note 8: Definition of Chromaticity:

The color coordinates (Xw, Yw), (XR, YR), (XG, YG), and (XB, YB) are obtained with all pixels in the viewing field at white, red, green, and blue states, respectively.

Note 9: Definition of Cross Talk (CT):

$$CT = | Y_B - Y_A | / Y_A \times 100 (\%),$$

where:

$Y_A$  = Luminance of measured location without darkest gray pattern ( $cd/m^2$ )

$Y_B$  = Luminance of measured location with darkest gray pattern ( $cd/m^2$ )

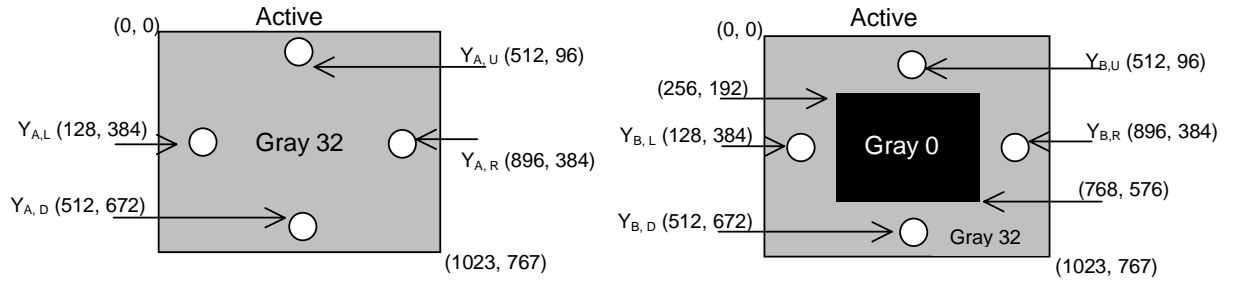

## 5. Reliability Test Item

No.	Test Item	Conditions	Criterion (Note)
1.	High temperature storage test	Ta = 60°C , 500h	#1,#2,#3,#4,#5
2.	Low temperature storage test	Ta = -20°C, 500h	#1,#2,#3,#4,#5
3.	High temperature and high humidity operation test	Ta = 40°C, 95%RH 500h ( no condensation )	#1,#2,#3,#4,#5
4.	High temperature operation test	Ta = 55°C, 500 h	#1,#2,#3,#4,#5
5.	Low temperature operation test	Ta = -5°C, 48h	#1,#2,#3,#4,#5
6.	Vibration test ( operating )	10 ~ 500 Hz, 1 G, 20 min./cycle, X,Y,Z, each 3 times	#3,#4,#5
7.	Mechanical shock ( non-operating )	50 G, 11 ms, half sine wave, X,Y,Z, each 1 times	#3,#4,#5

Note : The criterions are as following.

#1 : The Contrast Ratio criterion after this test item are  $\Delta CR \leq 20\%$  or  $CR >$  minimal specification.

$\Delta CR$  is the contrast ratio variation which is measured before and after this test item.

#2 : The module Power Supply Current (  $I_{cc}$  )  $\leq$  Maximal Specification after this testing item.

#3 : The module is functional work after this test item.

#4 : The defect or mura are not increase after this test item.

#5 : The mechanical outline is no abnormal change , for example, inflation, distortion or metal frame shift.

## 6. MECHANICAL DRAWING

Please refer to the attached drawings.

---

## 7. PRECAUTION

### 7.1 ASSEMBLY AND HANDLING PRECAUTION

- (1) Do not apply rough force such as bending or twisting to the module during assembly.
- (2) To assembly and install module into user's system are only in clean working areas. The Dust and oil may cause an electrical short or worsen the polarizer.
- (3) It's not permitted to pressure or impulse the module because the LCD panel and backlight.
- (4) Always follow the correct power sequence when user connects and operates the LCD module to prevent damage to the CMOS LSI chips during latchup.
- (5) Do not pull the I/F connectors in or out while the module is operation.
- (6) Do not disassembly the module.
- (7) Use a soft dry cloth without chemicals for cleaning, because the surface of polarizer is very soft and easily scratched.
- (8) Any moisture come into contact with the LCD module is dangerous because LCD modules is turned on with moisture on its surface may cause it damage.
- (9) The high temperature or humidity may reduce the performance of module, to store LCD module within the specified storage condition.
- (10)The ambient temperature is lower than 10°C may reduce the display quality, for example, response time become slowly, the starting voltage of CCFL is higher than room temperature.

### 7.2 SAFTY PRECAUTION

- (1) The startup voltage of backlight is approximately 1000 Volts. It may cause electrical shock during assembly with inverter. Do not disassemble the module or insert anything into the backlight unit.
- (2) If the liquid crystal material leaks from the panel, it should be kept away from the eyes or mouth. In case of contact with hands, skin or clothes, it has to be washed away thoroughly with soap.

## 8. PACKAGING

### 8.1 PACKING SPECIFICATIONS

- (1) 10 LCD modules / 1 Box
- (2) Box dimensions : 443(L) X 433(W) X 388(H) mm
- (3) Weight : approximately 14.5 Kg ( 10 modules per box)

### 8.1 PACKING Method

The Figure. 8-1,2 show the packing method.

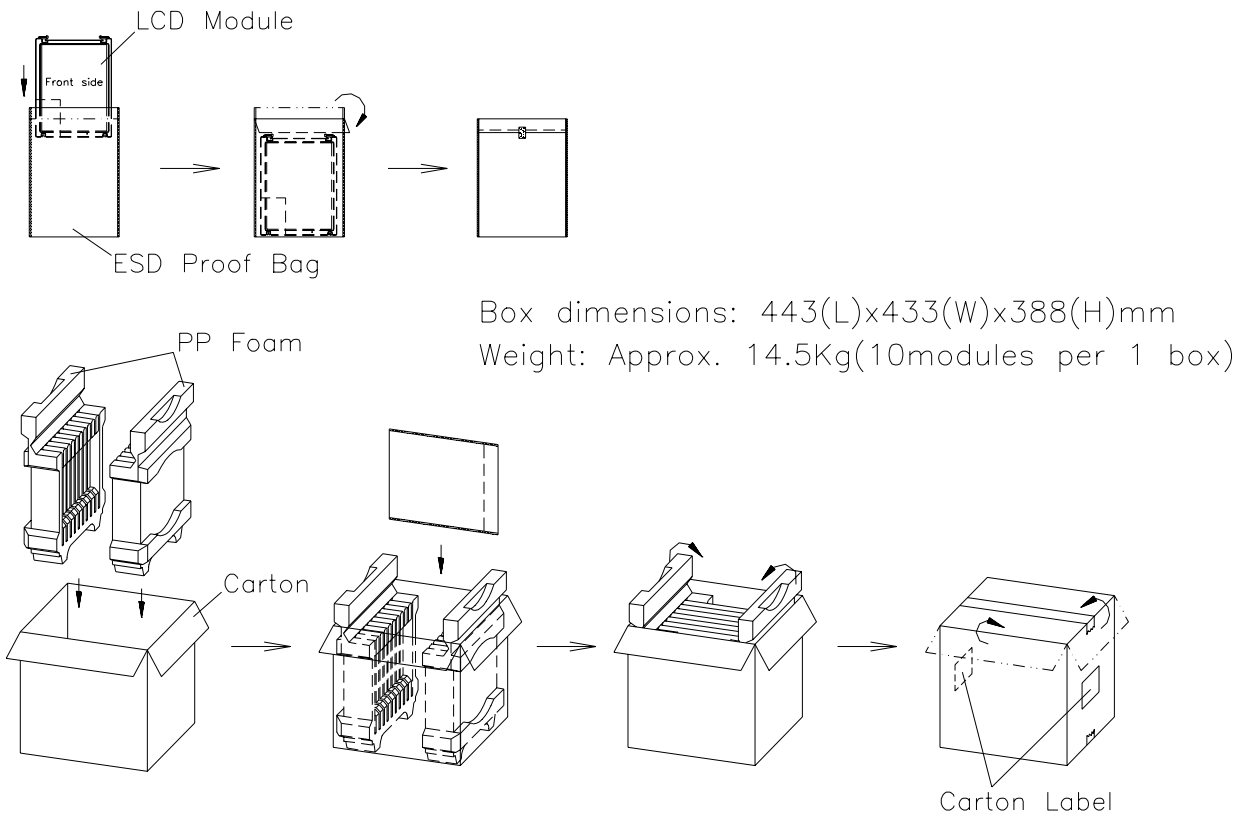

**Figure. 8-1 Packing method**

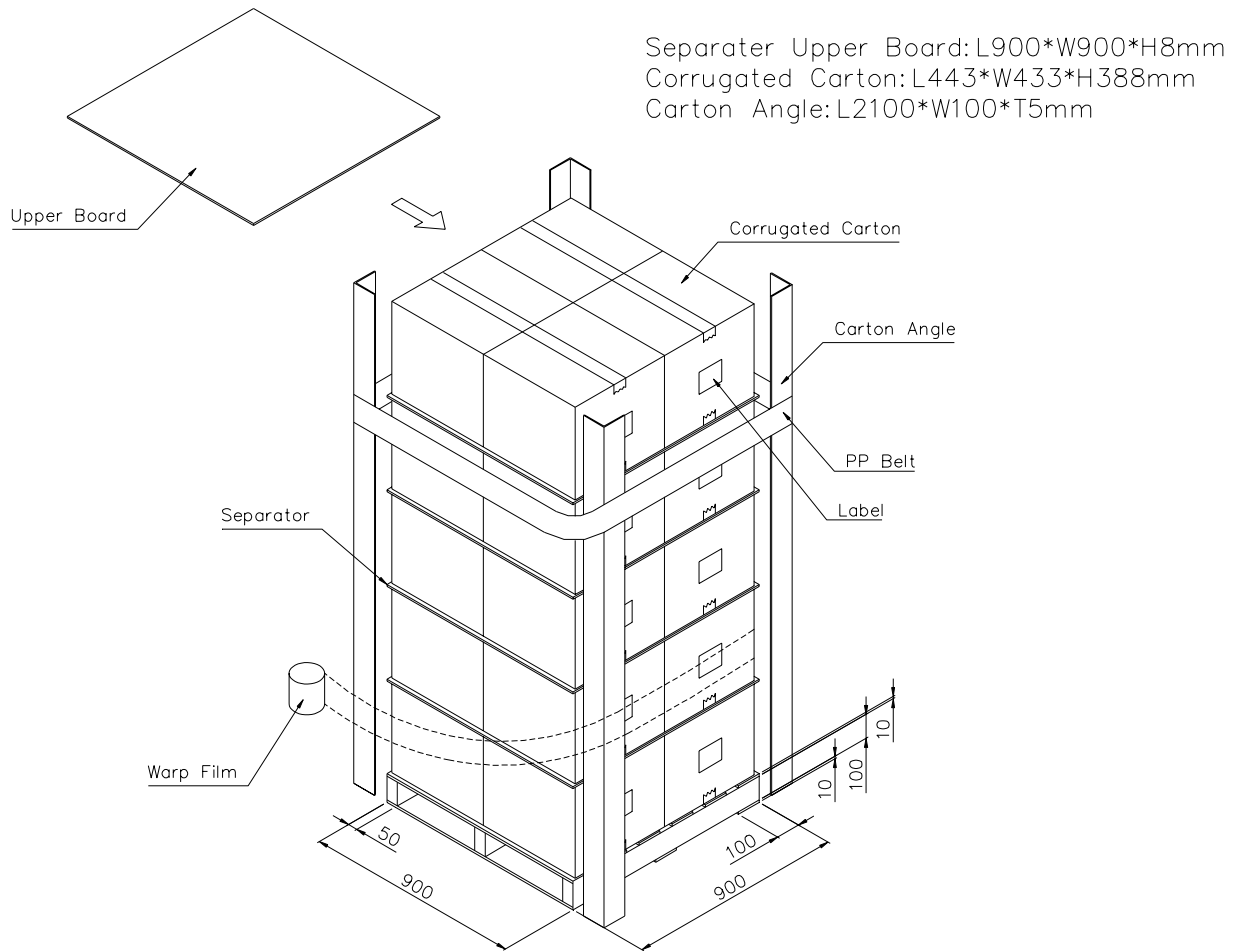

**Figure. 8-2 Packing method**

---

## 9. INCOMING INSPECTION DAY

The Supplier should be acquainted the inspection results (acceptance or rejection) by Customer, and the results are in accordance with the incoming inspection standard within 30 days after the date of the bills of lading.

Should Customer fail to so notify the Supplier within the said 30 days period. The Customer's right to reject the LCMS shall then lapse, and the said LCMS shall be deemed to have been accepted by the customer.



## 10. Definition of Shipping Label on Module

The barcode nameplate is pasted on each module as illustration, and its definitions are as following explanation.

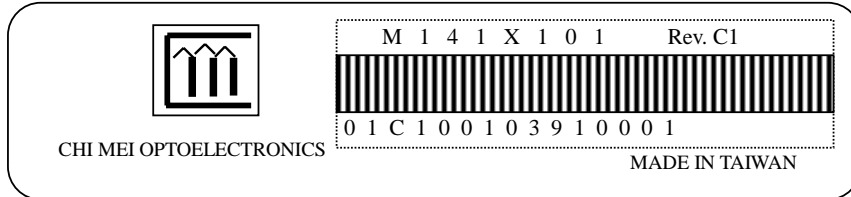

- (1) Model Name : M141X101
- (2) Revision : Rev.XX, for example : C1, C2 ...etc.
- (3) Serial ID : 0 1 C 1 0 0 1 0 3 9 1 0 0 0 1

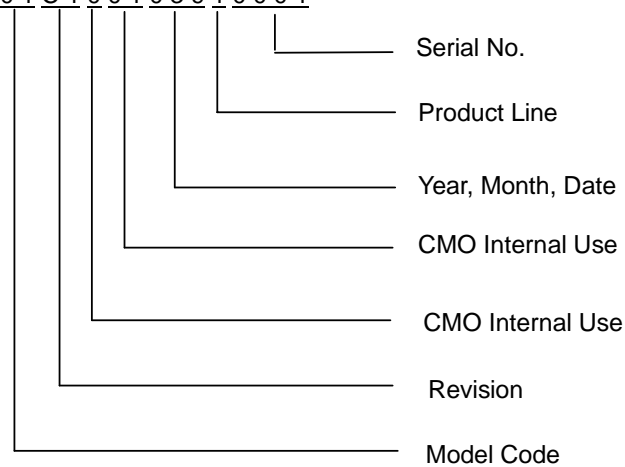

Serial ID include the information as list.

1. Manufactured Date : Year : 0~9, for 2000~2009  
 Month : 0~9, A~C, for Jan. ~ Dec.  
 Day : 0~9, A~Y, for 1<sup>st</sup> to 31<sup>st</sup>, exclude I and O
2. Revision Code : cover all the change
3. Model code
4. Serial No. : Manufacturing sequence of product
5. Product Line : 1 -> Line1, 2 -> Line 2 ...,etc.



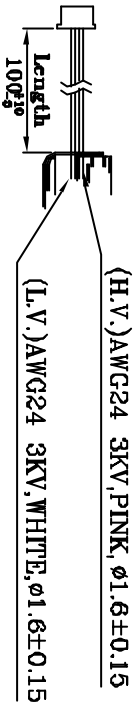
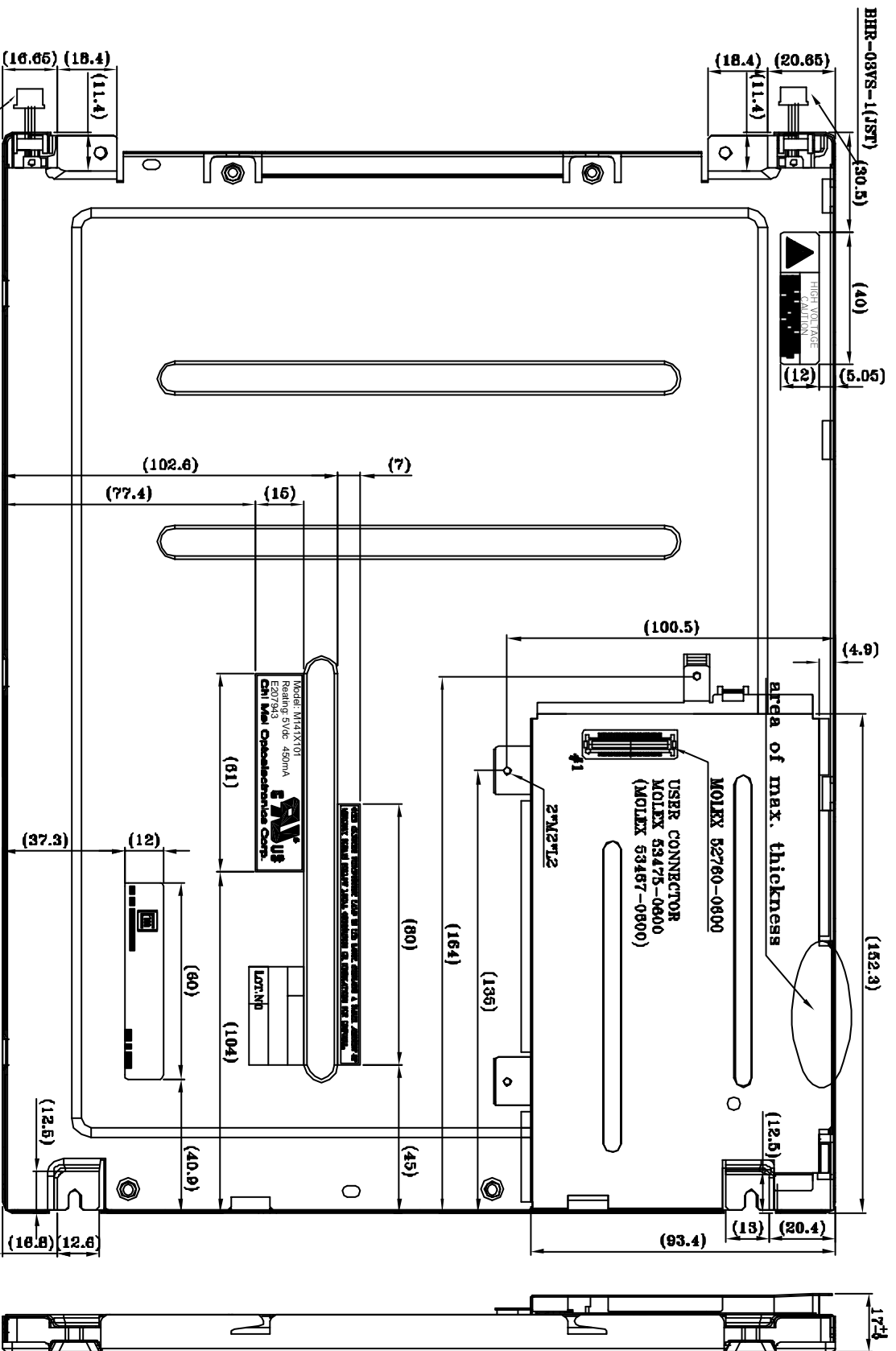

Unspecified Dim's Tolerance :  $\pm 0.3\text{mm}$

MARK	DESCRIPTION	DATE	CHANGE BY	APPROVAL BY	ECN NO.
8		7			
7					
6					
5					
4					
3					
2					
1					

 <b>CHI MEI</b> OPTOELECTRONICS CORP.		DWG NO.: M14114117A DATE: 05/19/2000
APPROVED:	CHECKED:	
DESIGNER: DAVID LN	PART NO.:	SCALE:
DRAWER: DAVID LN	REV.: A	SHEET:
TITLE: Outline M141X101	UNIT: MM	2/2

CHI MEI COPYRIGHT 2000. ALL RIGHTS RESERVED. COPYING FORBIDDEN.