



STCC02-BD5

CONTROL CIRCUIT FOR HOME APPLIANCE MCU BASED APPLICATION

APPLICATIONS

- Microwaves oven analog and power driver control
- Home Appliance digital control

FEATURES

- Wide range input supply voltage operation: 7 to 27 V
- 5 V \pm 10% full tolerance Voltage Regulator
- MCU reset circuit with activation delay timer and 45 μ s digital noise filter
- Highly immune and 30 μ s filtered Zero Voltage Synchronization
- Door Closed detection adaptation
- One 100 mA fan relay coil driver with demagnetizing diode
- One 100 mA magnetron relay coil driver with demagnetizing diode including down lock circuit based on fan drive output state
- One 10 mA buzzer driver
- Ambient temperature: - 10 to 85 °C

BENEFITS

- Higher module compactness with reduced component count
- Drastic reduction of soldered pins on the board for faster module assembly time and lower use of lead
- High ESD robustness and transient burst immunity compliant with IEC61000-4 standards
- Enhanced functional reliability
- Accurate MCU supply for better Analog to Digital Conversion
- Enhanced circuit parametric quality
- Easy to design for short time to market

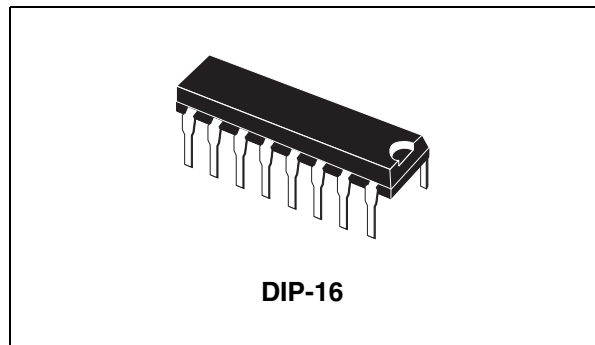

Table 1. Order Code

Part Number	Marking
STCC02-BD5	STCC02-B

Figure 1: STCC02 Based Application Diagram

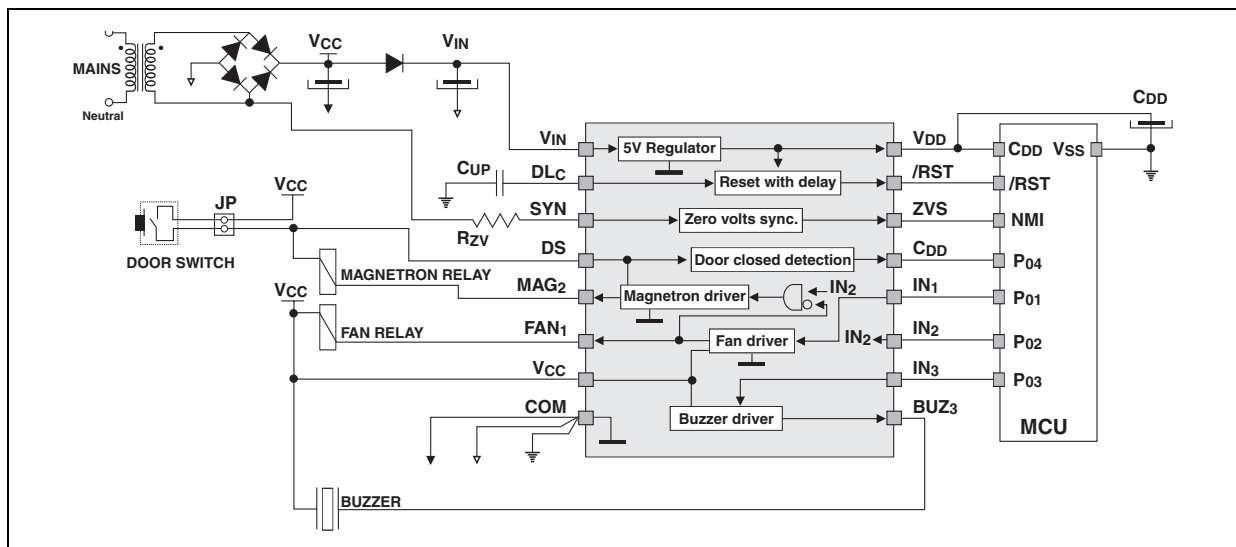

Figure 2: Pin-out connections

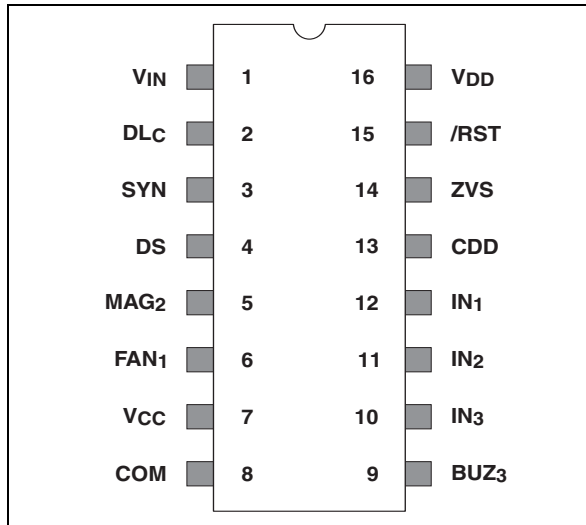
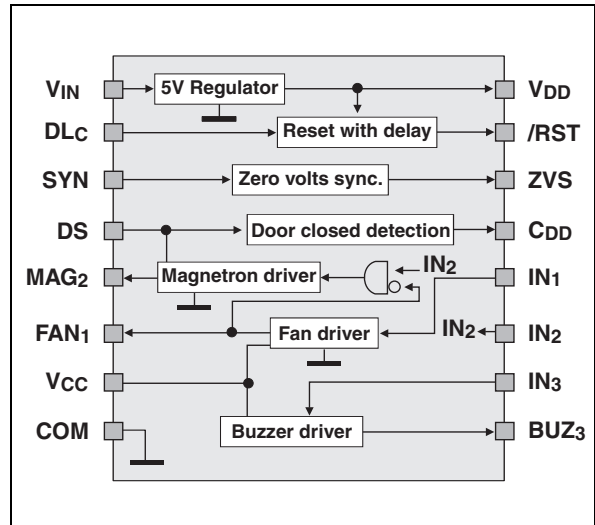

Figure 3: Block diagram



FUNCTIONAL DESCRIPTION

The STCC02 is a control circuit embedding most of the analog & power circuitry of a microwaves oven control module. It interfaces the micro-controller with the power and process sections of the oven.

■ **The voltage supply**

The 5V voltage regulator supplies the micro-controller MCU: especially functions such as the timer, the Analog-Digital Converter ADC, and the low current outputs. Since all the high-current outputs sink their current from a different voltage supply, this regulator does not need to be oversized. Its average output current can vary from 5 to 20 mA.

Its output voltage accuracy, that contributes to the ADC accuracy of the MCU, is better than $\pm 10\%$ in the whole operating range of the temperature T_{AMB} , the load current I_{DD} and the input voltage V_{IN} . The STCC02 input voltage range from 7 to 27 V; and its DC output current is less than 20 mA to keep the internal dissipation compatible with thermal package capability.

The regulator includes also an over current limiter to prevent high current conditions during the power up inrush or the output short circuit. This limiter is made of a serial shunt resistance as current sensor and a circuit that regulates the input over current.

■ **The reset circuit**

This circuit ensures a Low Voltage Detection (LVD) of the output voltage of the regulator. Most micro-controllers have an active RESET pin in the low state: so, the /RST pin will be active at low state.

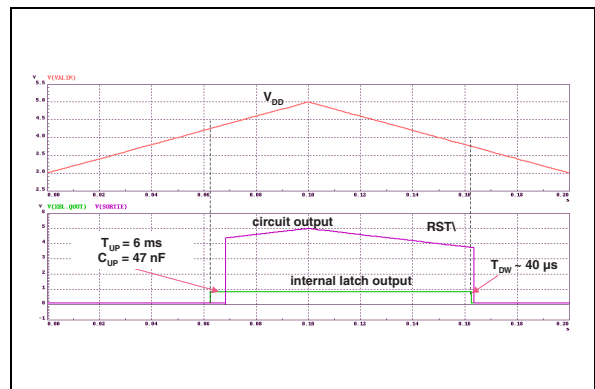
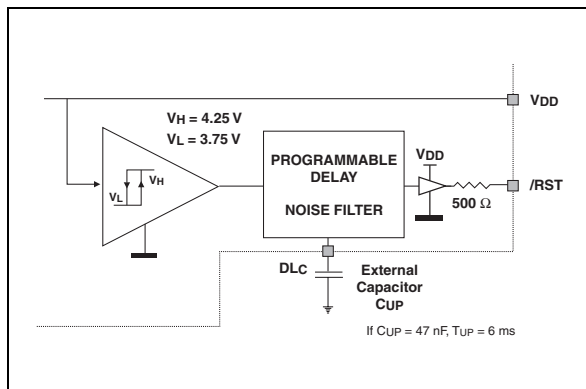

The reset circuit senses the regulator voltage V_{DD} . Its comparator with hysteresis achieves this task. The /RST pin is high when V_{DD} is higher than the high threshold $V_H = 4.25$ V; and is low when the V_{DD} decreases below the low threshold $V_L = 3.75$ V.

The comparator output changes are filtered for a high immunity. When the reset is disabling ($V_{DD} > V_H$), the /RST signal rises after the delay time T_{UP} . This delay is set by an external capacitor C_{UP} connected to the DL_C pin: $T_{UP} = 6$ ms for $C_{UP} = 47$ nF.

When the reset is enabling ($V_{DD} < V_L$), the /RST signal is falling after a delay time T_{DW} that is internally set at 40 μ s when $C_{UP} = 47$ nF.

■ The Zero Voltage Synchronization ZVS circuit

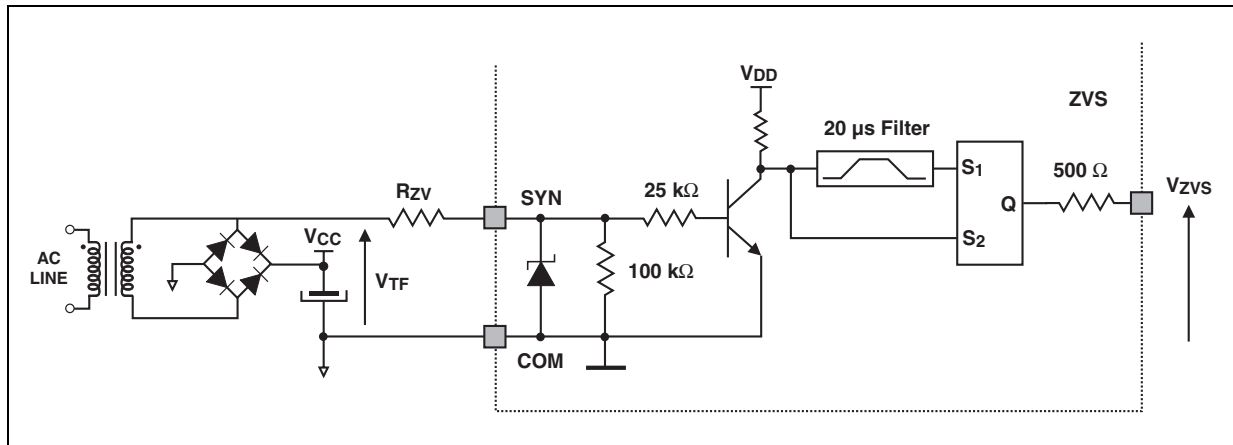

The Zero Voltage Synchronization ZVS circuit generates a low frequency clock using the AC line cycles (20 ms on 50 Hz or 16.7 ms on 60 Hz). This clock allows the MCU to generate the cooking timings and to reduce the magnetron inrush current by powering it on at the AC line peak voltage.

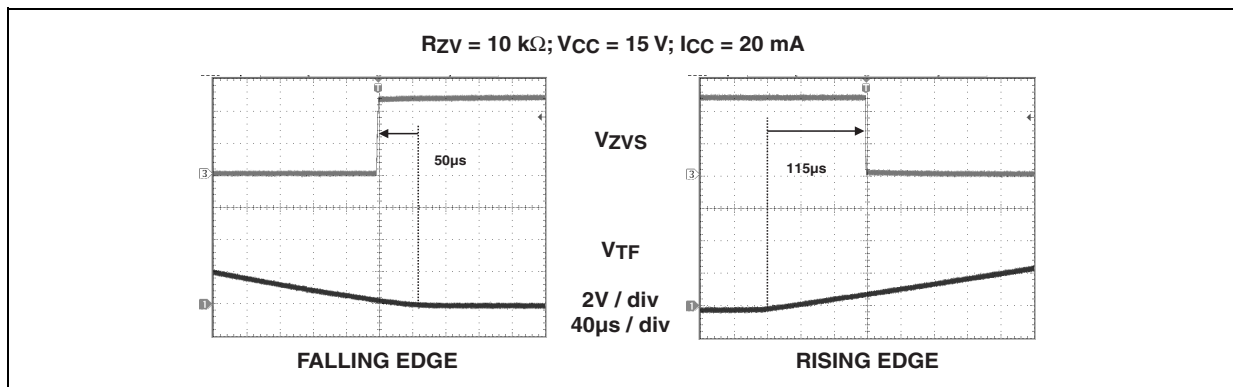

The input pin SYN is an image of the mains voltage and is usually connected to the supply transformer through a resistor R_{ZV} .

The circuit is protected against fast line transients because its state change will act on the whole MCU routines: a 30 μ s filter is implemented giving a higher immunity to the MCU circuit.

Since the ZVS pin is connected to the Non Maskable Interrupt NMI or INT\ of the MCU, its falling edge is the active counting event. The delay between the real Zero Crossing event and this ZVS falling edge depends on the internal filtering time, the resistance R_{ZV} , the transformer, the rectifier drop voltage V_F , the V_{CC} supply load and the temperature. The STCC02 contribution to this delay can be evaluated by measuring the delay between its input voltage V_{TF} and its output voltage V_{ZVS} . When using $V_F = 0.8$ V, $R_{ZV} = 10$ k Ω , $V_{CC} = 15$ V, $I_{CC} = 20$ mA, it is about 50 μ s on rising voltage V_{TF} and 115 μ s on falling voltage V_{TF} .

■ The Door closed detection circuit

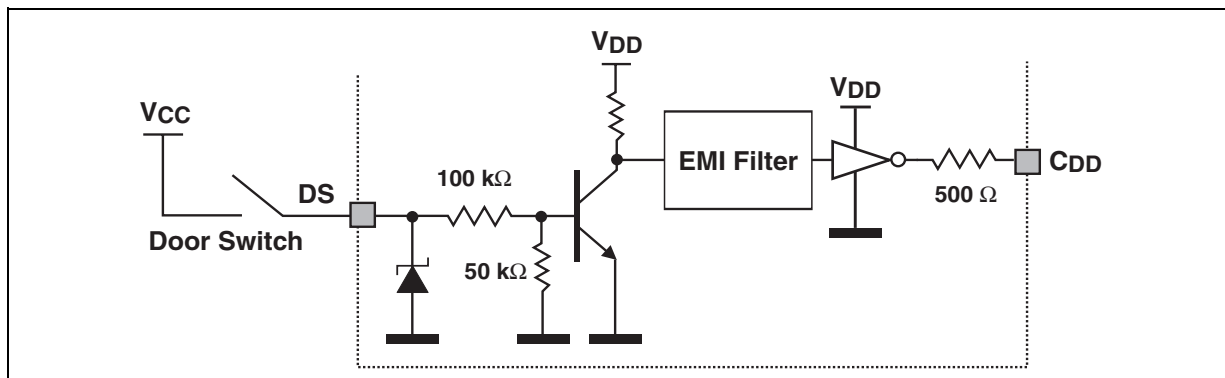

The magnetron of the oven can be powered only if the door is closed in order to protect the oven user. This safety feature is ensured mechanically by putting the door switch in series with the magnetron relay coil supply.

For redundancy purpose, the Door Closed Detection CDD signal is also transmitted to the MCU. Since the DS input detects the door state from an electromechanical switch, a spike suppressor is added to increase its robustness. Its EMI immunity in off state (open door) is increased thanks to a 50kΩ pull down resistor that maintains the DS signal in low state. When DS is high (24V), CDD signal is also in high state (5V).

■ The magnetron relay coil driver

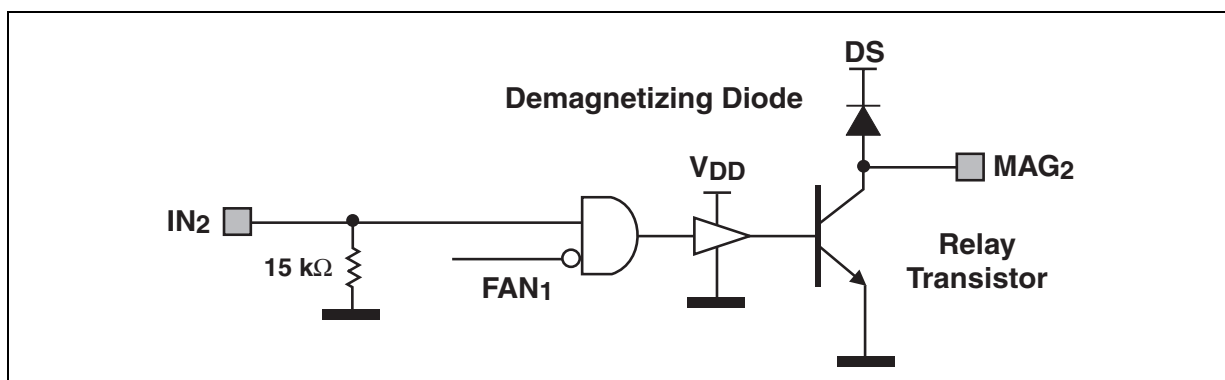

This robust driver interfaces a DC relay coil and an MCU output. The relay coil power is rated up to 1.2 W for $V_{CC} = 12V$.

Its output stage is made of a transistor and a demagnetization diode. The transistor's reference is to the power ground COM and has a DC current rating of 100 mA. Its collector is connected to the outputs MAG_2 . The diode is connected between the output pin MAG_2 and the Door Switch pin DS.

To enhance safety rules and to prevent any unventilated operation of the magnetron, the relay coil magnetization is enabled by the fan conduction state that becomes a logic signal FAN_1 .

Furthermore, its demagnetization node is connected to the door switch pin DS: when the oven door is open, the coil of the magnetron relay is immediately disconnected from the relay supply V_{CC} to switch off these heating loads.

The boolean rule of the magnetron relay operation becomes:

$$(\text{Magnetron relay ON}) = DS \cdot IN_2 \cdot FAN_1$$

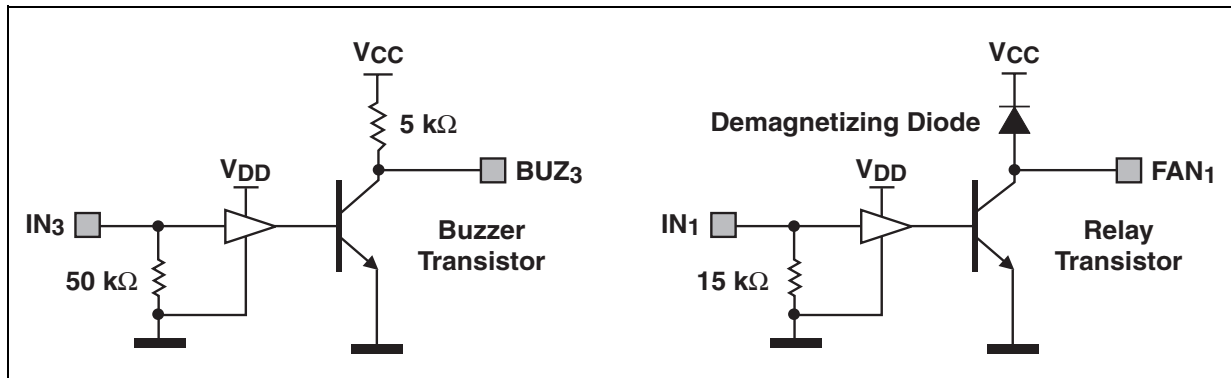

■ Fan relay coil driver

This robust driver interfaces a DC relay coil and an MCU output. The relay coil power is rated up to 1.2W for $V_{CC} = 12\text{ V}$.

Its output stage is made of a transistor and a demagnetization diode. The transistor is referred to the ground COM, has a DC current rating of 100 mA; and its collector is connected to the output FAN₁. The diode is connected between the output pin FAN₁ and the supply pin V_{CC} .

■ Buzzer driver

The MCU can drive a warning buzzer with a 50% PWM signal. The buzzer driver amplifies this signal in current and translates it from the 5V MCU output to the V_{CC} supply to produce the right sound level from the buzzer.

The output stage is made of a transistor and a 5 kΩ resistor. The transistor is referred to the power ground COM and is connected by its collector to the output BUZ₃. It has a DC current rating of 10 mA and runs up to 5 kHz. Finally, the resistor is connected between the BUZ₃ and V_{CC} pins to discharge the capacitance of the buzzer at turn off and in off state.

STCC02-BD5

Table 2: Absolute Ratings (limiting values)

Symbol	Pin	Parameter name & conditions	Value	Unit
V_{DD}	V_{DD}	Output supply voltage	- 0.3 to 6	V
V_{IN}	V_{IN}	Input supply voltage	- 0.3 to 30	V
V_{DS}, V_{CC}	DS, V_{CC}	Door switch and power supply voltage	- 0.3 to 30	V
V_{SYN}	SYN	AC input voltage, $R_{ZV} = 10k\Omega$	- 1 to 30	V
V_{MO}	BUZ ₁ , MAG ₂ , FAN ₁	Output voltage	- 0.3 to 30	V
V_I	IN ₁ , IN ₂ , IN ₃	Input logic voltage	- 0.3 to V_{DD} + 0.3V	V
V_O	ZVS, CDD, /RST	Output logic voltage	- 0.3 to V_{DD} + 0.3V	V
I_M	DS, V_{CC}	Maximum sourced current pulse, $t_p = 10ms$	120	mA
	MAG ₂ , FAN ₁	Maximum sunk driver current pulse, $t_p = 1ms$	120	mA
		Maximum DC sourced current	100	mA
	BUZ ₃	Maximum driver diode reverse current	15	mA
		Maximum DC sourced current	10	mA
MAG ₂ , FAN ₁	Maximum demagnetization diode reverse current	1	mA	
F_{MAX}	IN ₃ , BUZ ₃	Maximum buzzer frequency	5	kHz
P_{DIS}	All	Operating dissipation, DIL-16 package ⁽¹⁾	0.65	W
T_{AMB}	All	Operating ambient temperature, DIL-16	- 10 to 85	°C
T_J	All	Operating junction temperature	- 10 to 150	°C
		Storage junction temperature	- 25 to 150	°C

Note 1: Refer to the Application Recommendations for the calculation of the functional dissipation.

Table 3: Electromagnetic Compatibility Ratings

($T_J = 25^\circ\text{C}$, according to typical application diagram of page 1, unless otherwise specified)

Symbol	Node	Parameter name & conditions	Value	Unit
V_{ESD}	All pins	ESD protection, MIL-STD 883 method 3015, HBM model	± 2	kV

Table 4: Thermal Resistance

Symbol	Parameter	Value	Unit
$R_{th(j-a)}$	DIL-16 thermal resistance junction to ambient Copper thickness = 35 μm	100	°C/W

Table 5: Tentative Electrical Characteristics ($T_J = 25^\circ\text{C}$, $V_{CC} = 12\text{V}$, unless otherwise specified)

Symbol	Pin	Name	Conditions	Min.	Typ	Max.	Unit
Voltage supply							
V_{DD}	V_{DD}	Output voltage supply	$I_{DD} = 5$ to 20mA $T_{\text{amb}} = -10$ to 85°C $V_{IN} = 7$ to 27V $C_{DD} = 10\mu\text{F}$	4.5	5	5.5	V
V_{IN}	V_{IN}	Input supply voltage		7		27	V
I_{SQ}	V_{IN}	Quiescent supply current	$V_{DD} = 5\text{V}$, $I_{DD} = 0$ (open)		1.25	2.5	mA
I_{SM}	V_{IN}	Internal circuit current ($I_{IN} - I_{DS}$)	$V_{IN1} = V_{IN2} = V_{IN3} = V_{DD}$ $I_{DD} = 20\text{mA}$		1.9	3	mA
I_{IN_SC}	V_{IN}	Limiting input current	$V_{DD} = 0\text{V}$ Output in short circuit		45	90	mA
Reset circuit							
V_H	/RST	Disabling reset threshold			4.25	4.5	V
V_L		Enabling reset threshold		3.3	3.75		V
V_{HYS}		Threshold hysteresis		0.3	0.5		V
T_{UP}		Disabling reset delay time	$C_{UP} = 47\text{nF}$	1	6		ms
T_{DW}		Enabling reset delay time	$C_{UP} = 47\text{nF}$		45		μs
Zero Voltage synchronization circuit							
T_D	SYN ZVS	Transition filtering time	$V_{TF} = 0$ to V_{CC} rising and falling step	10	30	70	μs
V_{TH}	SYN	Transition threshold		0.4	0.6	0.9	V
I_{SYN}	SYN	Input activating current	$R_{ZV} = 10\text{k}\Omega$, $V_{SYN} = 24\text{V}$		0.8	2	mA
Door closed detection circuit							
V_{DSH}	DS	Closed door detection		7		27	V
V_{DSL}		Open door detection				0.8	V
I_{DS}		Internal input current	$V_{DS} = 27\text{V}$		230	800	μA
Door closed detection, zero voltage synchronization, reset circuits							
V_{OH}	CDD /RST ZVS	High level output voltage		$0.8 V_{DD}$			V
V_{OL}		Low level output voltage				$0.2 V_{DD}$	V
Fan relay coil driver							
I_{IN1}	IN_1	Input activating current	$V_{IN1} = V_{DD}$		300	800	μA
V_{ON}	FAN ₁	On state output voltage	$I_{ON} = 100\text{mA}$, $V_{IN1} > 3.5\text{V}$		1	1.5	V
V_{FAN1H}		Off state output voltage	$V_{IN1} < 1\text{V}$, $R_L = 110\Omega$	$0.9 V_{CC}$		V_{CC}	V
Magnetron relay coil driver							
I_{IN2}	IN_2	Input activating current	$V_{IN2} = V_{DD}$, $V_{FAN1} < 1.5\text{V}$		300	800	μA
V_{ON}	MAG ₂	On state output voltage	$I_{ON} = 100\text{mA}$, $V_{IN2} > 3.5\text{V}$ $V_{FAN1} < 1.5\text{V}$		1	1.5	V
V_{MAG2H}		Off state output voltage	$V_{IN2} < 1\text{V}$, $R_L = 110\Omega$	$0.9 V_{DS}$		V_{DS}	V
Buzzer driver							
I_{IN3}	IN_3	Input activating current	$V_{IN3} = V_{DD}$		60	200	μA
F_{BUZ}		Buzzer PWM frequency	Duty cycle = 50%		2		kHz
V_{BUZ3H}	BUZ ₃	Off state output voltage	V_{IN1}	$0.9 V_{CC}$		V_{CC}	V
V_{ON}		On state output voltage	$I_{ON} = 10\text{mA}$, $V_{IN3} > 3.5\text{V}$		1.2	1.8	V
R_{BUZ}		Buzzer resistance to V_{CC}			4.7		k Ω

DC CHARACTERISTICS FIGURES

Figure 4: Regulator characteristic with $T_j = 25^\circ\text{C}$ and $V_{IN} = 12\text{V}$

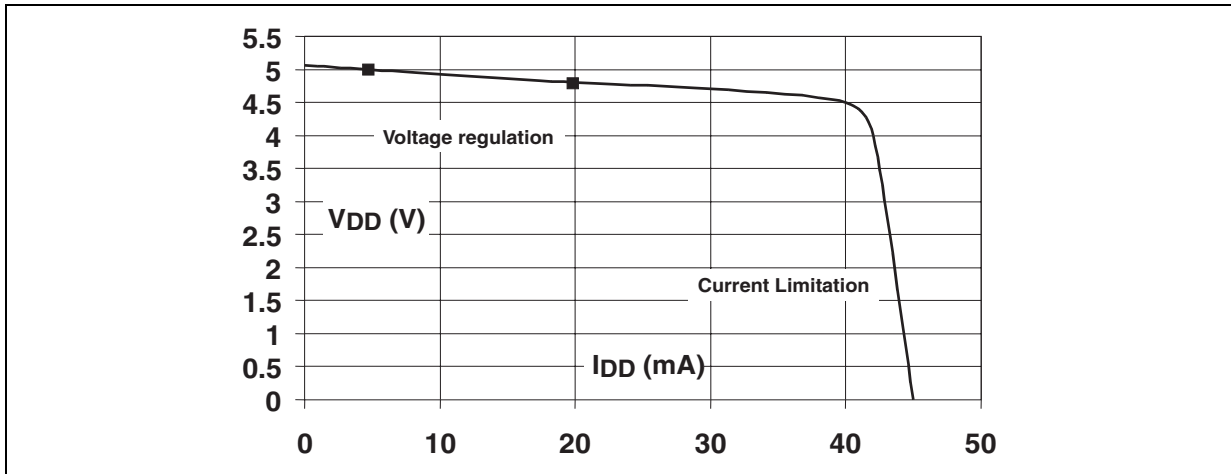

Figure 5: Regulator output voltage versus its junction temperature with $V_{IN} = 12\text{V}$

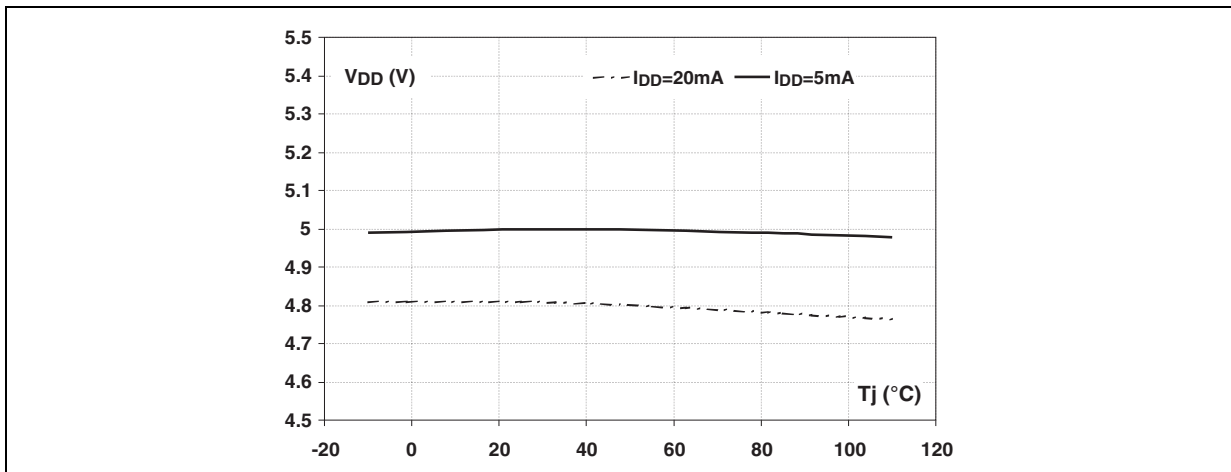
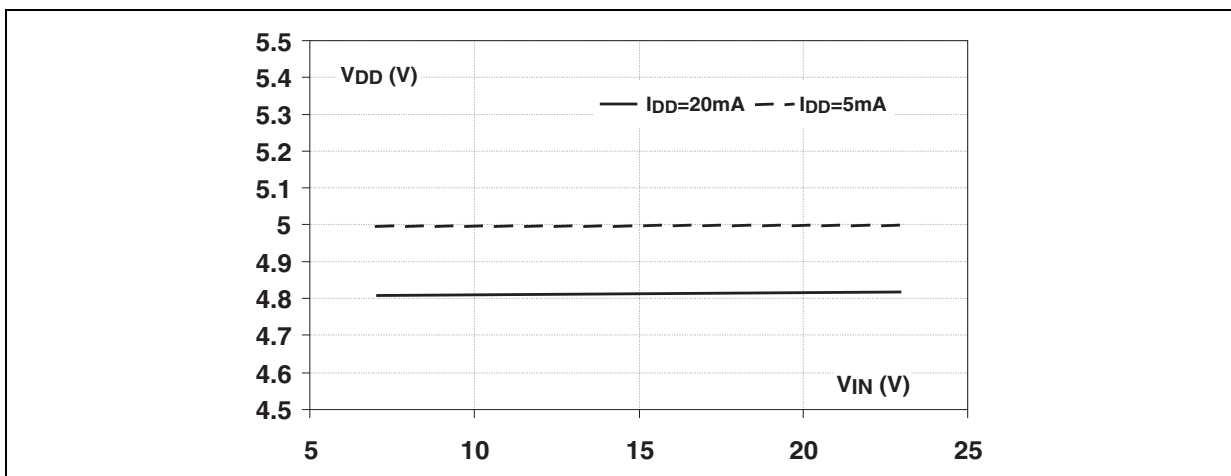

Figure 6: Regulator output voltage versus its input voltage with $I_{DD} = 5$ and 20mA and $T_j = 25^\circ\text{C}$



APPLICATION RECOMMENDATIONS

■ EVALUATION OF THE STCC02 DISSIPATION IN ITS APPLICATION

In order to define accurately at which maximum input supply voltage the STCC02 can work safely, the dissipated power has to be evaluated. Indeed, the STCC02 device can withstand voltages up to 30V, as specified in the "ABSOLUTE RATINGS" section.

However, when the V_{IN} voltage is high, it will also increase the power dissipation P_{DIS} and the junction temperature T_J of the whole circuit.

For the evaluation of the maximum junction temperature, the following equation should be used to calculate dissipated power:

$$P_{DIS} = (V_{IN} - V_{DD}) \times I_{DD} + V_{IN} \cdot I_Q + V_{ON} \times (I_{M@FAN1} + I_{M@MAG2} + I_{M@BUZ3})$$

Indeed, the power dissipation is mainly due to the regulator and to the currents sunk by the three driver outputs FAN_1 , MAG_2 , and BUZ_3 .

Furthermore, the input voltage V_{IN} is linked to the relays conduction in most applications. When the relay coils are driven, the storage supply capacitor is discharged and V_{IN} is no longer equal to the peak voltage of the transformer secondary winding. In this case, V_{IN} should approach the average value of the secondary voltage. This value is then approximately 36% lower than in stand-by operation, as explained by the following equation:

$$V_{IN}(relays_on) \approx \frac{2}{\pi} \times V_{IN}(relays_off)$$

When the relays are off, the dissipation losses formula is:

$$P_{DIS} = (V_{IN} - V_{DD}) \times I_{DD} \times I_Q$$

For instance if $V_{IN} = 27V$, $V_{DD} = 5V$, $I_Q = 2.5mA$, $I_{DD} = 20mA$, the dissipated power in the STCC02 is evaluated at 0.51W.

When the relays are on, the full formula of the dissipation losses is applied. For instance in the same AC line conditions with the relays on, V_{IN} drops down to 17.5V. Considering $I_{M@BUZ3} = 10mA$, $I_{M@FAN1} = I_{M@MAG2} = 100mA$ and $V_{ON} = 1.5V$, the dissipated power in the STCC02 becomes 0.61W. The maximum junction temperature is given by:

$$T_{Jmax} = T_{AMBmax} + R_{th(j-a)} \times P_{DIS}$$

The maximum allowed input supply voltage is then chosen in order to keep the junction temperature below its maximum operating value 150°C.

Since the maximum junction temperature is 150°C, the maximum ambient temperature T_{AMB} is 85°C in this application, and the thermal resistance is 100°C/W, the maximum allowed dissipation becomes 0.65 W.

The two dissipation cases described above are compatible with the package dissipation capability.

Otherwise, the ambient temperature T_{AMB} , the input voltage V_{IN} or the load current I_{DD} should be limited by design to meet the circuit thermal requirements.

■ IMMUNITY IMPROVEMENT OF STCC02 AND ITS MICROCONTROLLER

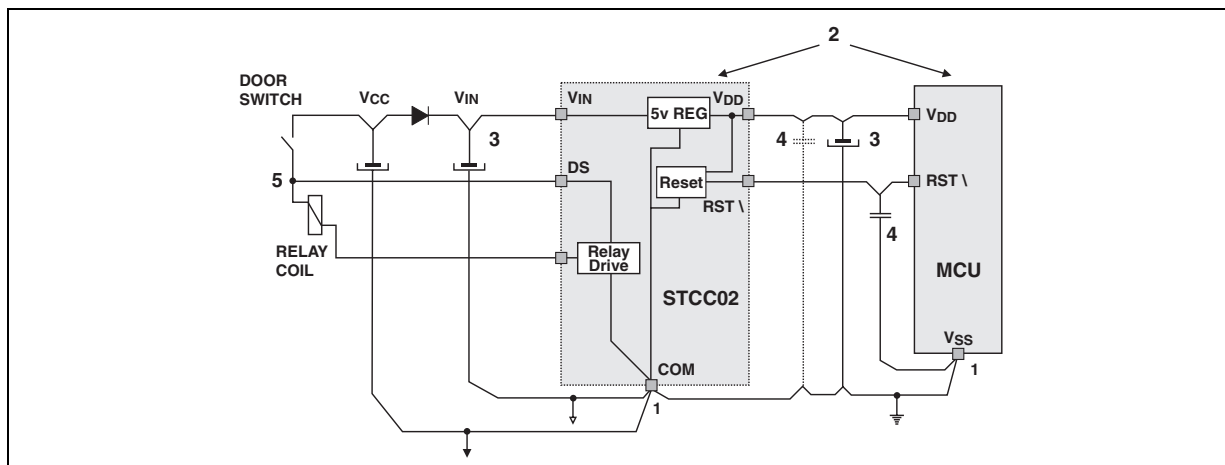

Some basic rules can be applied to improve the STCC02 immunity in its application:

- The power grounds of V_{CC} and DS should be split from the signal ground V_{SS} . (1)
- The STCC02 is placed as close as possible of the MCU; (2)
- The supply capacitors would increase the system immunity by being placed closed to the blocks they feed; (3)
- Wide supply copper plane should be avoided to reduce sensitivity to radiated interferences.

More specifically with the STCC02 circuit,

- A decoupling capacitor can be put on the STCC02 pins SYN and the MCU reset pin; (4)
- Depending of the PCB layout quality, others capacitors may be put on sensitive pins such as the output regulator pin V_{DD} , the synchronization circuit pin ZVS or the door switch pin DS.

The power door switch is a well-identified electrical noise source for the electronic board. Its effect should be reduced as much as possible. For instance, its power wires should be twisted together and split from other wires. Its signal wires should be also twisted; and on the PCB, the V_{CC} forward track and the DS signal reward track should be linked to reduce EMI on the signal DS. (5)

■ ELECTROMAGNETIC COMPATIBILITY TEST CIRCUIT

Standards such IEC61000-4-X evaluate the electromagnetic compatibility of appliance systems. To test the immunity level of the STCC02 to the IEC61000-4-4 (transient bursts), a board representative of usual control unit for microwave oven has been developed, as shown on top of page 11. One characteristics of the IEC61000-4-4 test, is that no measurement equipment can be connected to the tested system, as it would corrupt the test results. That is why this board includes a remote monitoring circuit based on optic fibers. Thus, without any electrical link with an oscilloscope, it is possible to monitor the VDD voltage as well as the RESET or the ZVS outputs of the STCC02, during the IEC61000-4-4 test. This optical link detects parasitic commutations of outputs as short as 60ns.

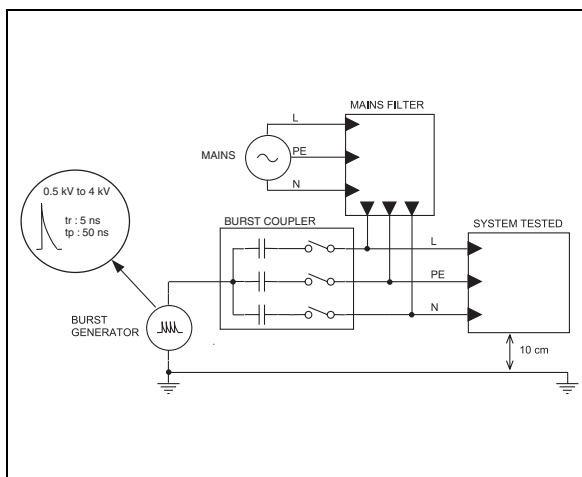

With this board, and the burst generator coupled to the mains as specified in the IEC61000-4-4 standard (see the above principle diagram), the STCC02 has been tested successfully at 4kV.

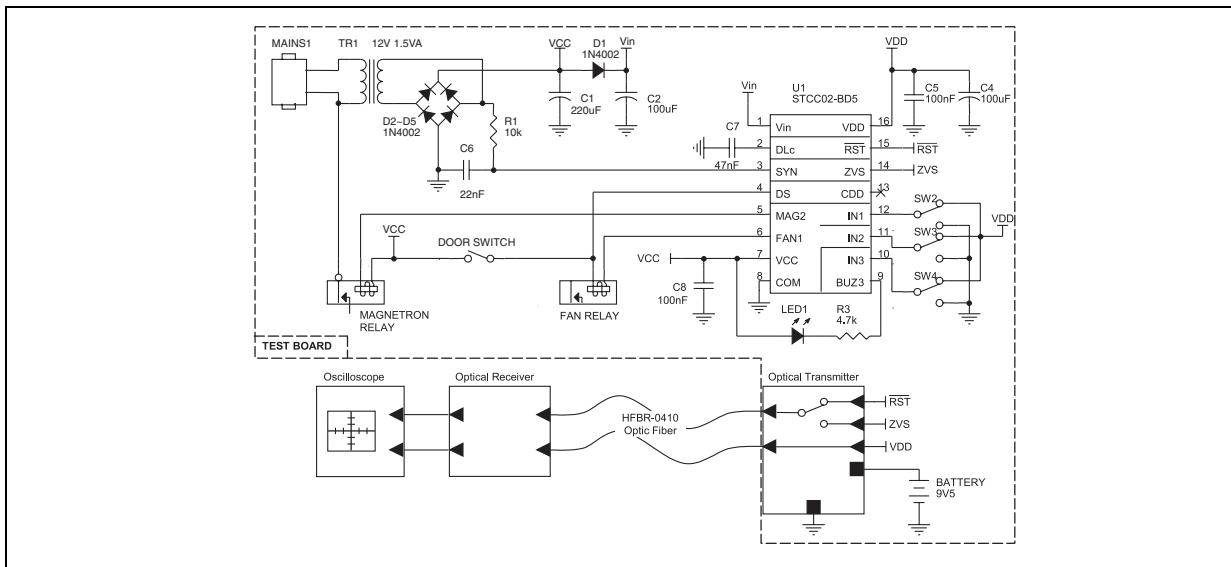

ZVS CIRCUIT COMPATIBILITY WITH THE POWER SUPPLY RECTIFIER BRIDGE

In some cases, the operation of the ZVS circuit may require a small capacitor C_{ZV} on the pin SYN in addition to the resistor R_{ZV} . The diodes of the full wave rectifier bridge may have a low speed and may switch off with recovery charges that create spikes on the pin SYN as shown on the waveforms below. With a $10k\Omega - 22nF$ RC circuit, the ZVS circuit becomes immune to such spikes.

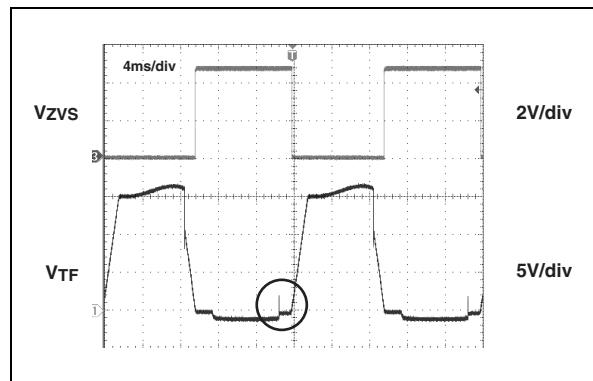
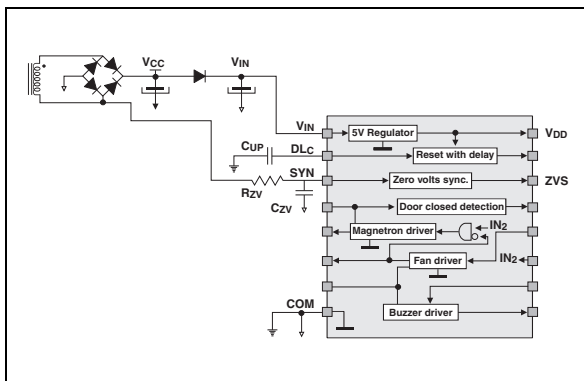

OPEN DOOR SIGNAL IMMUNITY

The door-closed signal is achieved by a high side switch connected between the VCC polarity and the DS pin. When the door switch is off and the magnetron relay coils not supplied anymore, the low state signal is secured by the internal pull-down resistor of DS pin ($50k\Omega$).

In noisy environment with radiated interferences, the off state of the DS signal (open door) can be reinforced by adding a resistor from DS pin to the ground COM. Its resistance can be chosen from $50 k\Omega$ to $22 k\Omega$.

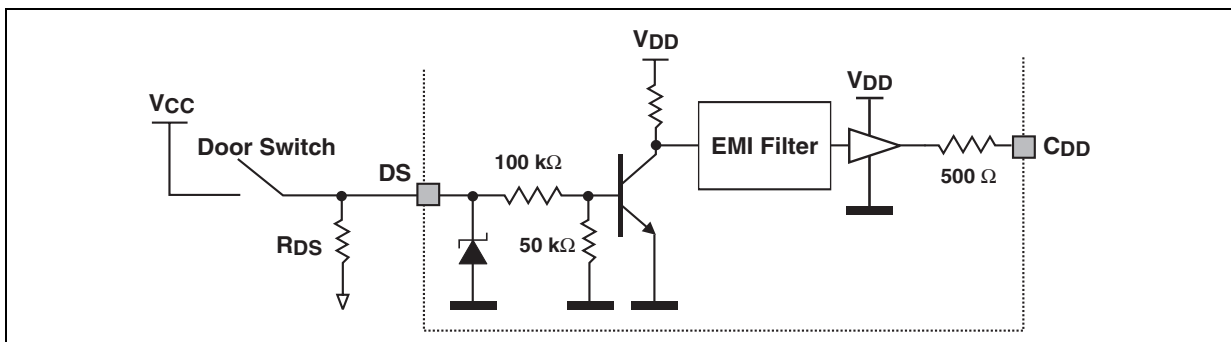

Figure 7: DIP-16 Package Mechanical Data

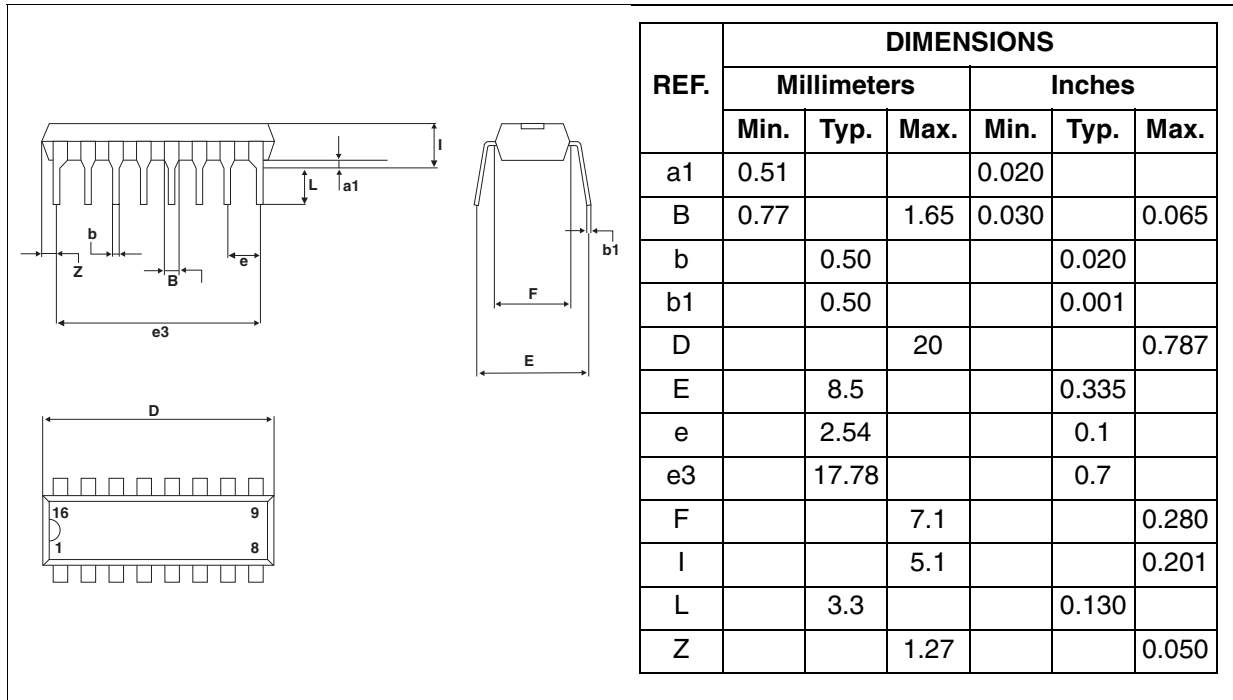

Table 6: Ordering Information

Part Number	Marking	Package	Weight	Base qty	Delivery mode
STCC02-BD5	STCC02-B	DIP-16	1 g	25	Tube

Table 7: Revision History

Date	Revision	Description of Changes
Jun-2003	1	First issue
08-Sep-2004	2	“Zero Voltage Synchronization ZVS circuit” drawing on page 3: ZVS value changed from 500KΩ to 500Ω
21-Oct-2004	3	Minor layout update. No content change.

Information furnished is believed to be accurate and reliable. However, STMicroelectronics assumes no responsibility for the consequences of use of such information nor for any infringement of patents or other rights of third parties which may result from its use. No license is granted by implication or otherwise under any patent or patent rights of STMicroelectronics. Specifications mentioned in this publication are subject to change without notice. This publication supersedes and replaces all information previously supplied. STMicroelectronics products are not authorized for use as critical components in life support devices or systems without express written approval of STMicroelectronics.

The ST logo is a registered trademark of STMicroelectronics.
All other names are the property of their respective owners

© 2004 STMicroelectronics - All rights reserved

STMicroelectronics group of companies

Australia - Belgium - Brazil - Canada - China - Czech Republic - Finland - France - Germany - Hong Kong - India - Israel - Italy - Japan -
Malaysia - Malta - Morocco - Singapore - Spain - Sweden - Switzerland - United Kingdom - United States of America
www.st.com