

TFT COLOR LCD MODULE

NL2432HC22-22B

8.9cm (3.5 Type)

QVGA

DATA SHEET 

DOD-PD-0401 (4th edition)

**This DATA SHEET is updated document from
DOD-PD-0223(3).**

**All information is subject to change without notice.
Please confirm the sales representative before
starting to design your system.**

INTRODUCTION

No part of this document shall be copied in any form or by any means without the prior written consent of NEC LCD Technologies, Ltd. (hereinafter called "NEC").

NEC does not assume any liability for infringement of patents, copyrights or other intellectual property rights of third parties by or arising from use of a product described herein or any other liability arising from use of such application. No license, express, implied or otherwise, is granted under any patents, copyrights or other intellectual property rights of NEC or of others.

While NEC has been making continuous effort to enhance the reliability of its products, the possibility of failures cannot be eliminated entirely. To minimize risks of damage to property or injury to person arising from a failure in an NEC product, customers must incorporate sufficient safety measures in their design, such as redundancy, fire-containment and anti-failure features.

NEC products are classified into the following three quality grades:
"Standard", "Special", "Specific"

The *"Specific"* quality grade applies only to applications developed based on a customer designated "quality assurance program" for a specific application. The recommended applications of a product depend on its quality grade, as indicated below. Customers must check the quality grade of each application before using it in a particular application.

Standard: Computers, office equipment, communications equipment, test and measurement equipment, audio and visual equipment, home electronic appliances, machine tools, personal electronic equipment and industrial robots

Special: Transportation equipment (automobiles, trains, ships, etc.), traffic control systems, anti-disaster systems, anti-crime systems, safety equipment and medical equipment (not specifically designed for life support)

Specific: Military systems, aircraft, aerospace equipment, submersible repeaters, nuclear reactor control systems, life support systems (medical equipment, etc.) and any other equipment

The quality grade of this product is *"Standard"* unless otherwise specified in this document. If customers intend to use this product for applications other than those specified for *"Standard"* quality grade, they should contact NEC sales representative in advance.

CONTENTS

INTRODUCTION 2

1. OUTLINE..... 4

 1.1 DESCRIPTION 4

 1.2 APPLICATION 4

 1.3 FEATURES..... 4

 1.4 STRUCTURES AND FUNCTION 4

2. GENERAL SPECIFICATIONS 5

3. BLOCK DIAGRAM..... 6

4. DETAILED SPECIFICATIONS 8

 4.1 MECHANICAL SPECIFICATIONS..... 8

 4.2 ABSOLUTE MAXIMUM RATINGS 9

 4.3 ELECTRICAL CHARACTERISTICS 10

 4.4 TOUCH PANEL CHARACTERISTICS 11

 4.5 POWER SUPPLY VOLTAGE SEQUENCE 12

 4.6 INTERFACE PIN CONNECTIONS 13

 4.7 DISPLAY COLORS vs. DISPLAY POSITIONS 15

 4.8 DISPLAY POSITIONS OF INPUT DATA..... 16

 4.9 INPUT SIGNAL TIMINGS..... 16

 4.10 OPTICAL CHARACTERISTICS 18

5. RELIABILITY TESTS..... 21

6. PRECAUTIONS 22

7. OUTLINE DRAWINGS 23

8. RECOMMENDATION DESIGN OF FRONT BEZEL 24

1. OUTLINE

1.1 DESCRIPTION

The NL2432HC22-22B is a TFT (thin film transistor) active matrix color liquid crystal display (LCD) comprising an amorphous silicon TFT attached to each signal electrode, a driving circuit. This module is consist of LCD panel, Driver, Backlight and Touch panel.

The 8.9 cm (3.5 Type) diagonal display area contains 240×320 pixels and can display 262,144 colors simultaneously.

1.2 APPLICATION

- PDAs

1.3 FEATURES

- Transflective type
- Backlight and touch panel attached
- Recommended LCD controller: Part No. S1L50282F23k100 (NEC corp.)
- High Brightness
- High contrast ratio
- Small footprint and light weight
- 6-bit digital RGB signals

1.4 STRUCTURES AND FUNCTION

Transflective TFT (thin film transistor) color LCD module is comprised of a TFT liquid crystal panel structure with LSIs for driving the TFT array. Sandwiching liquid crystal material in the narrow gap between a TFT array glass substrate and a color filter glass substrate creates the TFT panel structure.

RGB (red, green, blue) data signals from a source system are modulated into a form suitable for active-matrix addressing by the signal processor and sent to the driver LSIs, which in turn addresses the individual TFT cells.

Acting as an Electro-optical switch, each TFT cell regulates light from the natural light and so on when activated by the data source. By regulating the amount of light reflection passing through the array of red, green, and blue dots, color images are created with clarity.

2. GENERAL SPECIFICATIONS

Display area	53.64 (W) × 71.52 (H) mm	
Diagonal size of display	8.9 cm (3.5 inches)	
Drive system	a-Si TFT active matrix	
Display color	262,144 colors	
Pixel	240 (H) × 320 (V) pixels	
Pixel arrangement	RGB (Red dot, Green dot, Blue dot) vertical stripe	
Pixel pitch	0.2235 (W) × 0.2235 (H) mm	
Module size	64.0 (H) × 85.0 (V) × 4.13 (D) mm (typ.)	
Weight	37 g (typ.)	
Contrast ratio	At transmissive mode 90:1 (typ., at IL= 18mA, with Touch panel)	☆
	At reflective mode 6:1 (typ., with Touch panel)	☆
Reflection ratio	8% (typ., with Touch panel)	
Response time	39ms (typ. Ton + Toff)	
Luminance	90 cd/m ² (typ., at IL=18mA)	
	100 cd/m ² (typ., at IL=20mA)	
Signal system	Controller input (6-bit RGB data, DCK, DE, POC, OEN) signals	Note1
Supply voltage	VCC 3.0V (typ., Logic)	
	VDD 5.0V (typ., LCD H-driver)	
	VGON +15.0 V (typ., LCD V-driver)	
	VGOFF -15.0 V (typ., LCD V-driver)	
Power consumption	LCD panel: 29mW (typ.)	☆
	Backlight: 385mW (typ., at IL=18mA)	
	420mW (typ., at IL=20mA)	

Note1: Refer to the controller (Part No.: S1L50282F23k100) specifications.

3. BLOCK DIAGRAM

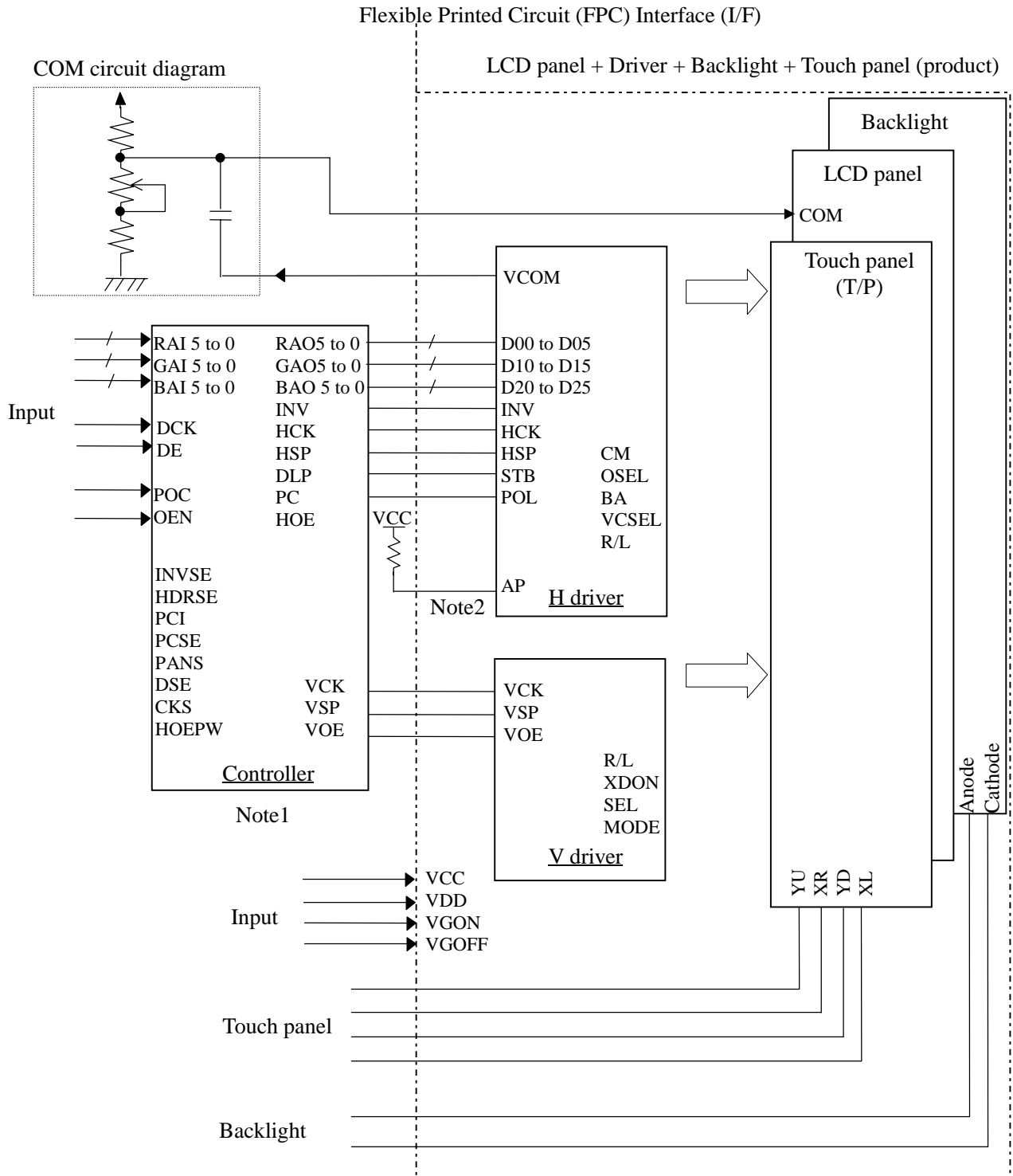

Note1 : Refer to the controller (Part No: S1L50282F23k100) specifications for input timings.

Note2: Connect "AP" to VCC, when the controller (part no.: S1L50282F23k100) is used.

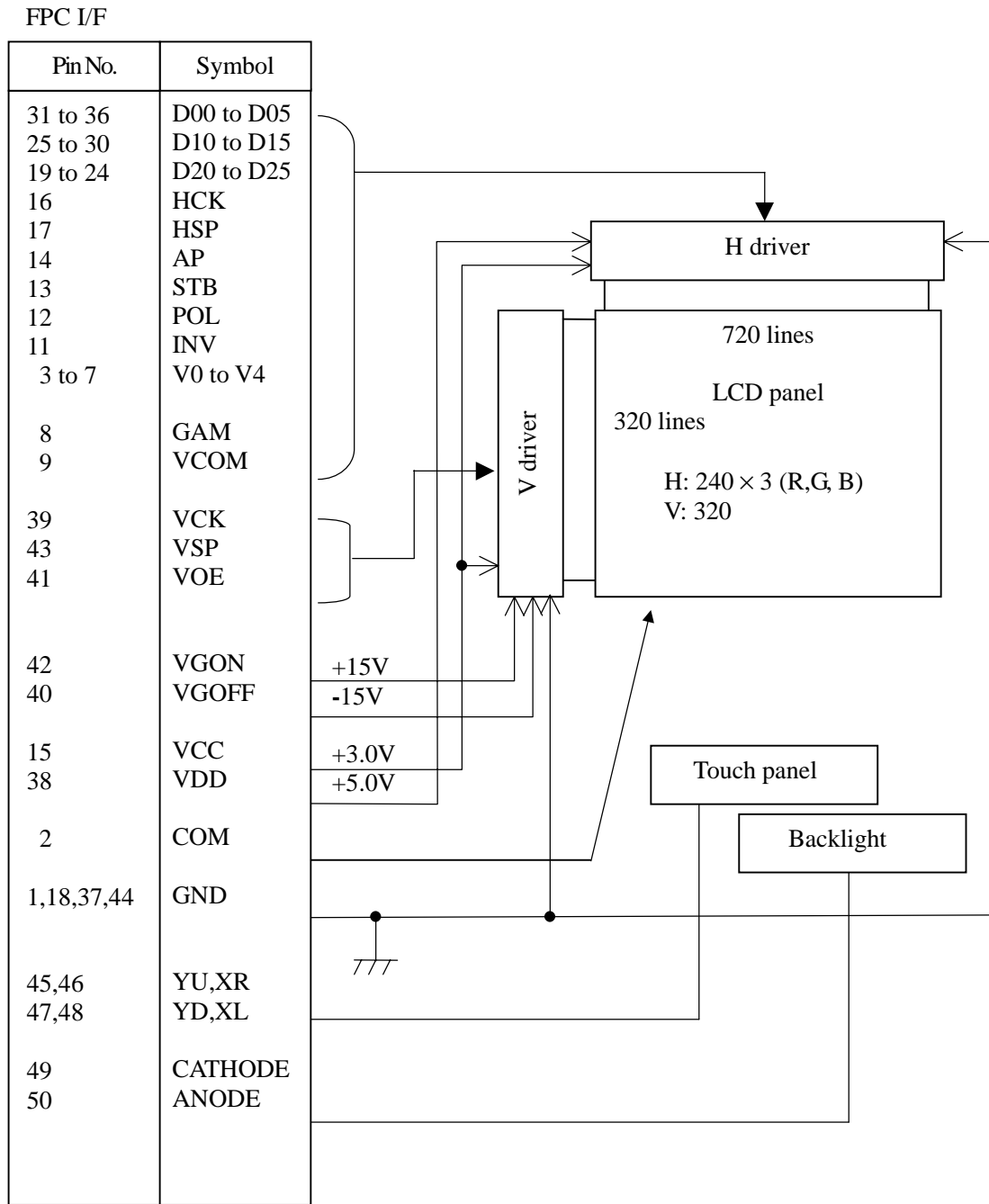

Reference design of COM circuit

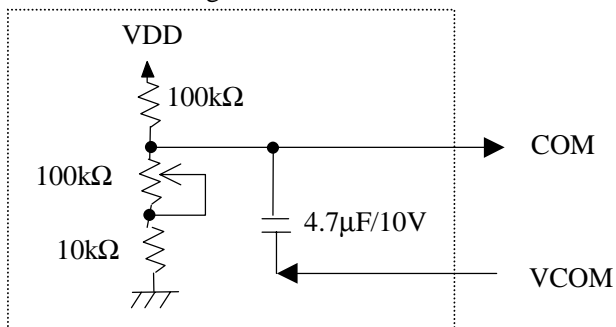

4. DETAILED SPECIFICATIONS

4.1 MECHANICAL SPECIFICATIONS

Parameter	Specification	Unit
Module size	64.0 ± 0.3 (H) × 85.0 ± 0.3 (V) × 4.13 ± 0.2 Max (D) [D: Not include FPC bending part]	mm
Display area	53.64 (H) × 71.52 (V)	mm
Number of pixels	240 (H) × 320 (V)	pixel
Dot pitch	0.0745 (H) × 0.2235 (V)	mm
Pixel pitch	0.2235 (H) × 0.2235 (V)	mm
Pixel arrangement	RGB (Red, Green, Blue) vertical stripe	-
Display colors	262,144	color
Weight	37 (typ.)	g

4.2 ABSOLUTE MAXIMUM RATINGS

Parameter	Symbol	Rating	Unit	Remarks
Supply voltage	VCC	-0.3 to +4.0	V	Ta = 25 °C
	VDD	-0.3 to +6.0	V	Ta = 25 °C
	VGON	-0.3 to +44.0		
	VGOFF	VGON -44.0 to +0.3		
Logic input voltage	VI	-0.3 to VCC+0.3	V	Logic signals
γ control voltage	V0 to V4	-0.3 to VDD+0.3	V	-
Reverse voltage (Backlight)	VR	≤ 30	V	Ta = 25 °C
Power dissipation (Backlight)	PD	≤ 720	mW	
Forward current (Backlight)	IL	Note1	mA	-
Storage temperature	Tst	-20 to +70	°C	-
Operating temperature	Top	-10 to +55		Product surface Note2
Relative humidity Note3	RH	≤ 95	%	Ta ≤ 40°C
		≤ 85		40°C < Ta ≤ 50°C
Absolute humidity Note3	AH	≤ 70 Note4	g/m ³	Ta > 50°C
Storage altitude		≤ 13,600	m	-20°C ≤ Ta ≤ 70°C
Operating altitude		≤ 4,850	m	-10°C ≤ Ta ≤ 55°C

Note1:

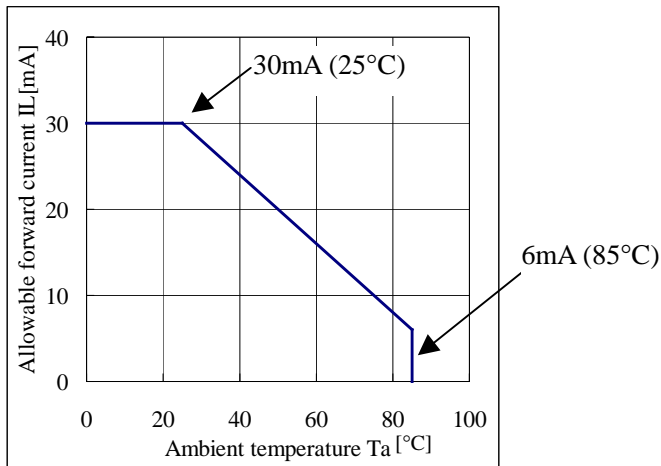

Note2: Measure at the display area

Note3: No condensation

Note4: Ta= 50°C, RH= 85%

4.3 ELECTRICAL CHARACTERISTICS

(1) Logic/ LCD driving

(Ta = 25°C)

Parameter	Symbol	min.	typ.	max.	Unit	Remarks
Logic supply voltage	VCC	2.6	3.0	3.6	V	-
H driver supply voltage	VDD	4.5	5.0	5.25	V	-
V driver (+) supply voltage	VGON	14.0	15.0	16.0	V	-
V driver (-) supply voltage	VGOFF	-16.0	-15.0	-14.0	V	-
Logic input high voltage	VIH	0.7 VCC	-	VCC	V	Logic signal
Logic input low voltage	VIL	0	-	0.3 VCC	V	
COM voltage input range	COM	VDD	-	-	Vp-p	-
COM center voltage	COM/C	-	1.65	-	V	at VDD=5.0 V Note1
VCC supply current	ICC	-	0.2	0.3	mA	at VCC= 3.0 V Note2 Not include the controller
VDD supply current	IDD	-	5.5	8.0	mA	at VDD = 5.0V AP pulse width = 30μs Note2 ☆
		-	7.5	10.0	mA	at VDD= 5.0V AP = "High" Note2 ☆
VGON supply current	IGON	-	0.04	0.1	mA	at VGON=+15.0 V Note2
VGOFF supply current	IGOFF	-	-0.04	-0.1	mA	at VGOFF= -15.0 V Note2

Note1: The optimum value for COM/C is in the range of 1.15V to 2.15V..

Note2: HCK= 5.6MHz, STB= 19.44kHz, VCK= 19.44kHz, VSP= 60Hz,
Checked flag pattern (by EIAJ ED-2522)

(2) Backlight

(Ta = 25°C)

Parameter	Symbol	min.	typ.	max.	Unit	Remarks
Forward current	IL	-	18	20	mA	-
Forward voltage	VL	17.6	21.2	23.8	V	at IL=18 mA

4.4 TOUCH PANEL CHARACTERISTICS

(1) Electrical characteristics

Parameter	Symbol	min.	typ.	max.	Unit	Remarks
Input voltage	Vtp	-	-	5.5	V	-
Resistor between pins (XL-XR)	Rx	200	-	650	Ω	-
Resistor between pins (YU-YD)	Ry	250	-	450	Ω	-
Line linearity (X direction)	Xlin	-	-	1.5	%	-
Line linearity (Y direction)	Ylin	-	-	1.5	%	-
Insulation resistance	Rins	20	-	-	M Ω	at DC 25V
Capacitance	Ctp	-	-	100	nF	-
Chattering	Chat	-	-	10	ms	-

☆
☆

(2) Mechanical characteristics

Parameter	Symbol	min.	typ.	max.	Unit	Remarks
Operation starting force	Ost	0.098 (10)	-	0.784 (80)	N (gf)	-
Surface hardness	Hs	3	-	-	H	Hardness of pencil

Input method: Finger or R0.8mm polyacetal stylus pen

(3) Input characteristics

Parameter	Symbol	Min.	Unit	Remarks
Point hitting life	Lhp	1,000,000	times	R0.8mm polyacetal stylus pen, 250g
	Lhr	1,000,000	times	R3 silicon rubber, 300g
Line writing life	Lwl	50,000	times	R0.8mm polyacetal stylus pen, 250g , 35mm

4.5 POWER SUPPLY VOLTAGE SEQUENCE

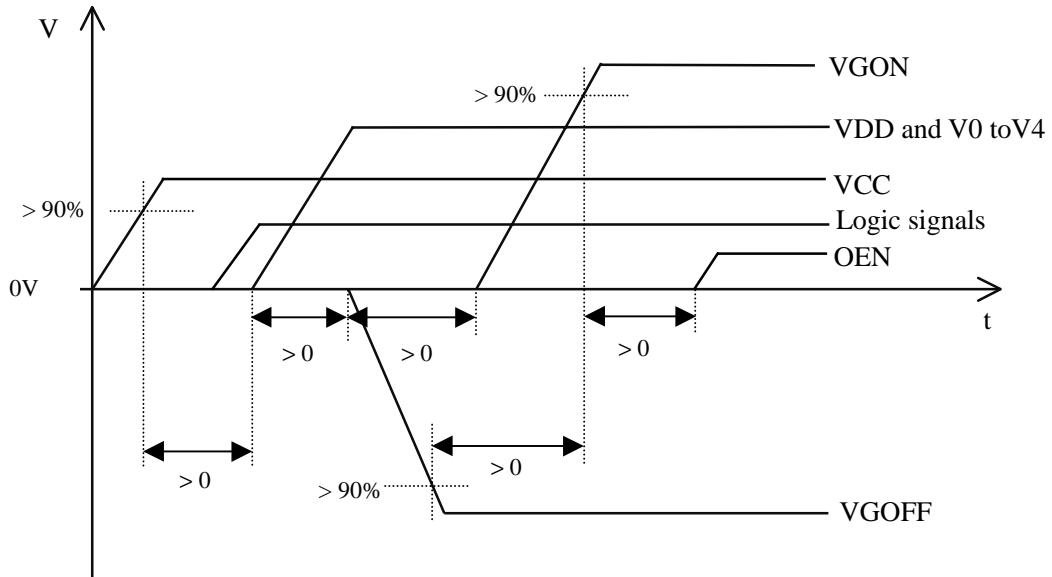

Remark1: Supply voltage sequence must be kept according to the above timings. And when it is turned off, the sequence must be reversed.

Remark2: The “OEN” signal of the controller must be “H” after V_{GON}.

Remark3: All signals should not be interrupted during the operation. Even if the signals recover, LCD module may not be operated correctly. In this case, reset the sequence again.

4.6 INTERFACE PIN CONNECTIONS

LCD panel signal processing board

CN1 (FPC)

Adaptable socket: FH12-50S-0.5SH (05) (Hirose Electric Co., Ltd.)

Pin No.	Symbol	Function	Pin No.	Symbol	Function
1	GND	Ground	26	D11	Green data
2	COM	Signal for common electrode	27	D12	Green data
3	V0	External gamma setting voltage (These pins must be Open when GAM pin is "L".)	28	D13	Green data
4	V1		29	D14	Green data
5	V2		30	D15	Green data (MSB)
6	V3		31	D00	Red data (LSB)
7	V4		32	D01	Red data
8	GAM	Gamma selection switch	33	D02	Red data
9	VCOM	Driver output signal	34	D03	Red data
10	N.C.	No connection (Keep this pin Open.)	35	D04	Red data
11	INV	Data inversion signal	36	D05	Red data (MSB)
12	POL	Polarity reversal signal	37	GND	Ground
13	STB	H driver latch signal	38	VDD	H driver voltage
14	AP	H driver inhibition signal	39	VCK	V driver shift clock
15	VCC	Logic voltage	40	VGOFF	V driver OFF voltage
16	HCK	H driver shift clock	41	VOE	V driver output enable ("L" output)
17	HSP	H driver start pulse	42	VGON	V driver ON voltage
18	GND	Ground	43	VSP	V driver start pulse
19	D20	Blue data (LSB)	44	GND	Ground
20	D21	Blue data	45	YU	Vertical terminal (Up side)
21	D22	Blue data	46	XR	Horizontal terminal (Right side)
22	D23	Blue data	47	YD	Vertical terminal (Down side)
23	D24	Blue data	48	XL	Horizontal terminal (Left side)
24	D25	Blue data (MSB)	49	CATHODE	LED voltage(Cathode)
25	D10	Green data (LSB)	50	ANODE	LED voltage(Anode)

Description of pin functions

Pin	Description
COM	This is the Common voltage. The voltage needs to be adjusted. See "3 BLOCK DIAGRAM - Reference design of COM circuit".
V0 to V4	Provide the gamma setting voltages from outside. Maintain the following voltage relationships. $VSS \leq V4 \leq V3 \leq V2 \leq V1 \leq V0 \leq VDD$
GAM	H: External gamma setting voltage (V0-V4) is valid. L: External gamma setting voltage (V0-V4) is invalid. (Internal gamma setting is valid.)
VCOM	This pin inverts the signal input from the POL pin and outputs it following conversion to the VDD potential at the rising edge of STB.
INV	This pin inverts the input data signal. Input data in synchronization with the shift clock. INV = L: Normal, INV = H: Data inversion
POL	This pin inverts the output polarity. The polarity inversion signal data is captured at the rising edge of STB. The gamma-resistor is switched in accordance with the positive/negative polarity. POL = H: Positive polarity POL = L: Negative polarity

To be continued

Continued

Pin	Description
STB	A timing signal that latches the contents of the data register. When an H level is read at the rising edge of HCK, the contents of the data register are latched and transferred to the D/A converter, and analog voltage corresponding to the display data is output. Also, because the internal operation via HCK continues even after the STB latch, do not stop HCK. The contents of the shift register are cleared at the rising edge of STB.
AP	This pin turns on/off the BIAS circuit and turns on the output SW and amplifier. When AP is H, the amplifier is set and the product is driving. The amplifier output and output SW are turned on at the rising edge of AP, starting the product drive. Note that the output SW is turned off at the rising edge of STB and the output becomes Hi-Z. Connect "AP" to VCC, when the controller (part no.: S1L50282F23k100) is used.
HCK	This pin is the shift clock input of the column shift register. Display data is captured into the data register at the rising edge.
HSP	Fetching of display data starts when H is read at the rising edge of HCK.
VCK	This pin is the shift clock input of the gate shift register. The start pulse is captured at the rising edge of clock and output the pulse at the falling edge.
VOE	This pin controls the output of the gate drivers. Output can be controlled regardless of VSP and VCK.
VSP	This pin synchronizes with the frame and the gate driver.
YU, XR, YD, XL	Refer to the below "Circuits of touch panel".
ANODE CATHODE	Refer to the below "Circuits of backlight".

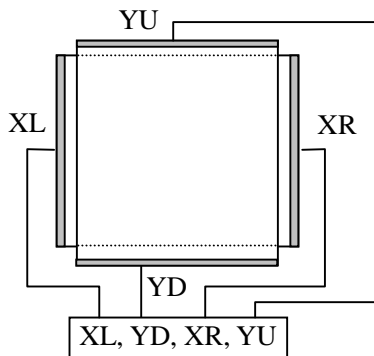

Circuits of touch panel

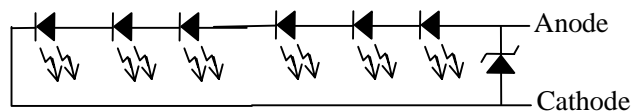

Circuits of backlight

Remark: Do not fold the FPC. When folding the FPC, pattern disconnection may be caused. In case of bending FPC, the minimum curvature (R) must be more than 1.0 mm.

4.7 DISPLAY COLORS vs. DISPLAY POSITIONS

Colors are developed in combination with 6-bit signals (64 steps in grayscale) of each primary red, green, and blue color. This process can result in up to 262,144 (64×64×64) colors.

The relation between display colors and input data signals is as the following table.

Display colors		Data signal (0: Low level, 1: High level)																	
		R5	R4	R3	R2	R1	R0	G5	G4	G3	G2	G1	G0	B5	B4	B3	B2	B1	B0
Basic colors	Black	0	0	0	0	0	0	0	0	0	0	0	0	0	0	0	0	0	0
	Blue	0	0	0	0	0	0	0	0	0	0	0	1	1	1	1	1	1	1
	Red	1	1	1	1	1	1	0	0	0	0	0	0	0	0	0	0	0	0
	Magenta	1	1	1	1	1	1	0	0	0	0	0	1	1	1	1	1	1	1
	Green	0	0	0	0	0	0	1	1	1	1	1	1	0	0	0	0	0	0
	Cyan	0	0	0	0	0	0	1	1	1	1	1	1	1	1	1	1	1	1
	Yellow	1	1	1	1	1	1	1	1	1	1	1	1	0	0	0	0	0	0
	White	1	1	1	1	1	1	1	1	1	1	1	1	1	1	1	1	1	1
Red scale	Black	0	0	0	0	0	0	0	0	0	0	0	0	0	0	0	0	0	0
		0	0	0	0	0	1	0	0	0	0	0	0	0	0	0	0	0	0
	dark	0	0	0	0	1	0	0	0	0	0	0	0	0	0	0	0	0	0
	↑				:						:					:			
	↓				:						:					:			
	bright	1	1	1	1	0	1	0	0	0	0	0	0	0	0	0	0	0	0
	1	1	1	1	1	0	0	0	0	0	0	0	0	0	0	0	0	0	
	1	1	1	1	1	1	0	0	0	0	0	0	0	0	0	0	0	0	
Green scale	Black	0	0	0	0	0	0	0	0	0	0	0	0	0	0	0	0	0	0
		0	0	0	0	0	0	0	0	0	1	0	0	0	0	0	0	0	0
	dark	0	0	0	0	0	0	0	0	0	1	0	0	0	0	0	0	0	0
	↑				:					:						:			
	↓				:					:						:			
	bright	0	0	0	0	0	0	1	1	1	1	0	1	0	0	0	0	0	0
	0	0	0	0	0	0	1	1	1	1	1	0	0	0	0	0	0	0	
	0	0	0	0	0	0	1	1	1	1	1	1	0	0	0	0	0	0	
Blue scale	Black	0	0	0	0	0	0	0	0	0	0	0	0	0	0	0	0	0	0
		0	0	0	0	0	0	0	0	0	0	0	0	0	0	0	0	0	1
	dark	0	0	0	0	0	0	0	0	0	0	0	0	0	0	0	0	1	0
	↑				:					:						:			
	↓				:					:						:			
	bright	0	0	0	0	0	0	0	0	0	0	0	1	1	1	1	0	1	1
	0	0	0	0	0	0	0	0	0	0	0	1	1	1	1	1	1	0	
	0	0	0	0	0	0	0	0	0	0	0	1	1	1	1	1	1	1	

4.8 DISPLAY POSITIONS OF INPUT DATA

The following table is the coordinates per pixel.

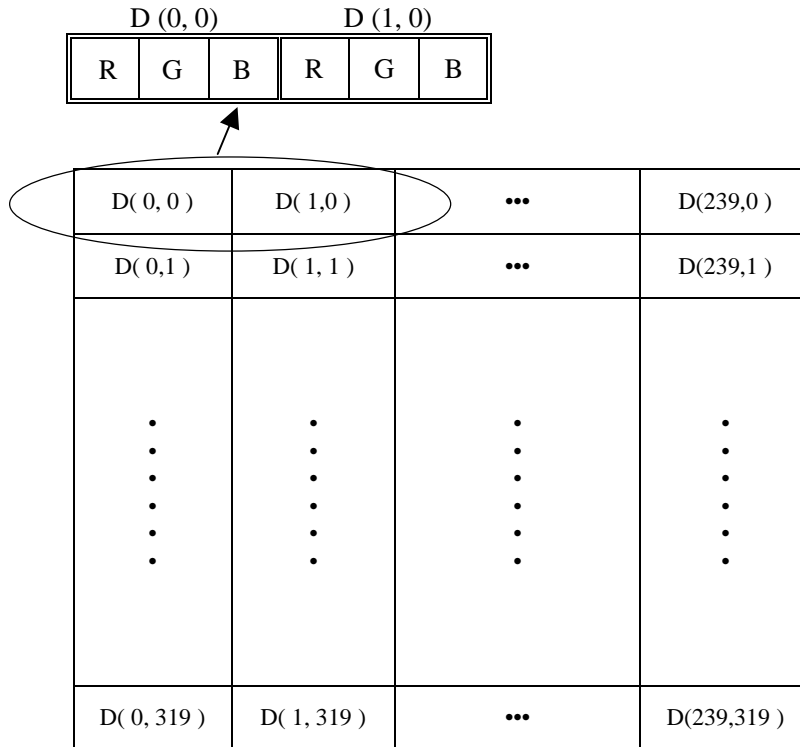

4.9 INPUT SIGNAL TIMINGS

Input signal specifications for LCD controller (Ta=25°C, VCC=3.0V, VDD=5.0V)

(1) Timing characteristic

Parameter	Symbol	min.	typ.	max.	Unit	Remarks
H Clock frequency	PPHCK	5.4	5.6	7.2	MHz	-
Last data timing	tLDT	2	-	-	CLK	-
STB frequency	PPSTB	16.5	19.44	20.0	kHz	-
STB pulse width	PWSTB	550	-	-	ns	-
STB-HSP time	tSTB-HSP	4	-	-	CLK	-
STB-AP time	tSTB-AP	5	7	-	μs	-
AP pulse width	PWAP	30	-	-	μs	-
VOE-AP time	tVOE-AP	0	10	-	μs	-
STB-POL time	tSTB-POL	40	-	-	ns	-
VCK-STB time	tVCK-STB	1	3	-	μs	-
VSP frequency	PPVSP	50	60	65	Hz	-
V Clock frequency	PPVCK	16.5	19.44	20	kHz	-

Remark: All parameters should be kept within the specified range.

(2) Horizontal timing chart

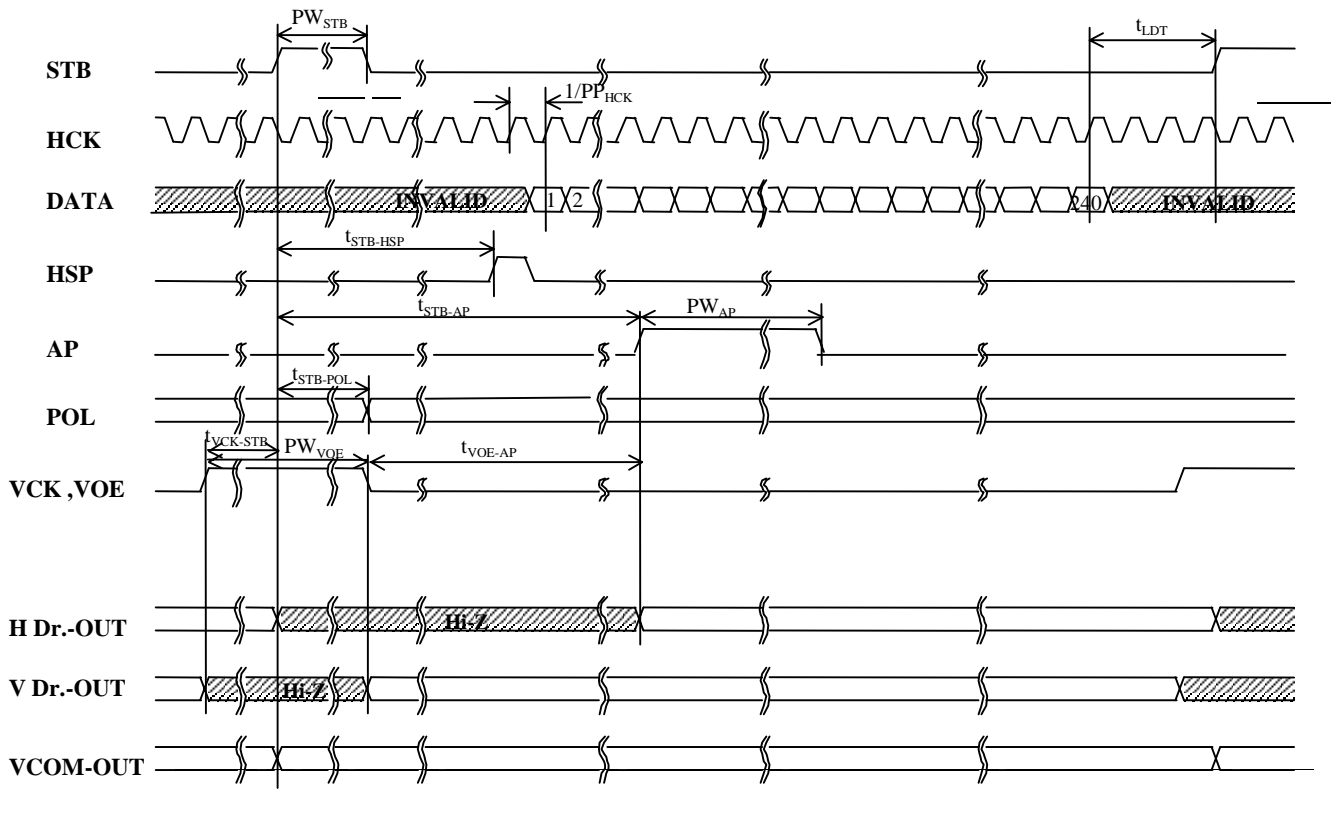

(3) Vertical timing chart

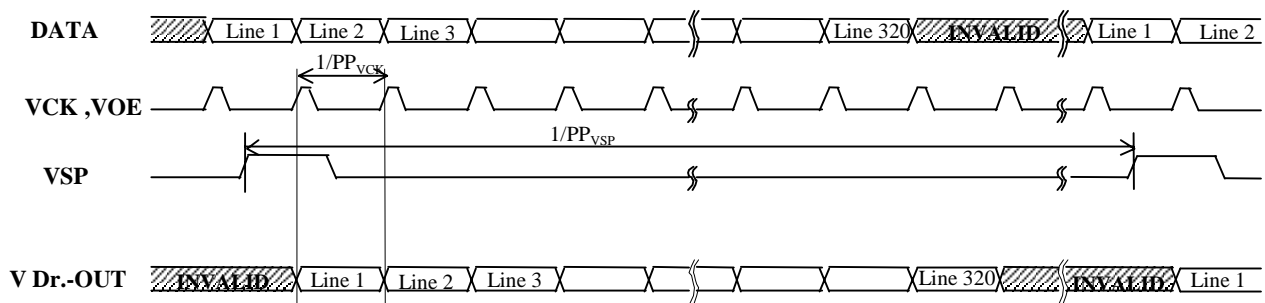

(4) Polarity of signal "POL"

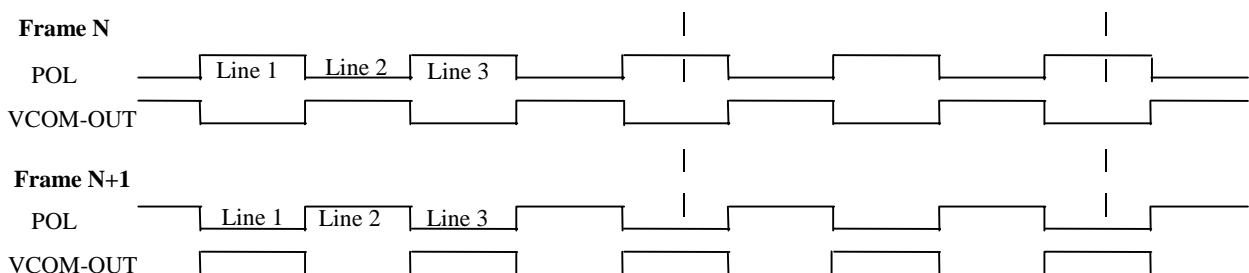

Remarks: Unless otherwise specified, the input level is defined to be $V_{IH} = 0.7V_{CC}$, $V_{IL} = 0.3V_{CC}$

4.10 OPTICAL CHARACTERISTICS

< Backlight turning off >

Note1

Parameter	Symbol	Condition	Min.	Typ.	Max.	Unit	Remarks
Contrast ratio	CR	-	4	6	-	-	Note2,3
Reflection ratio	RE	-	5	8	-	%	Note3

☆

Reference data

Note1

Parameter	Symbol	Condition	Min.	Typ.	Max.	Unit	Remarks	
Chromaticity coordinates	W	White (x, y)	-	(0.32,0.33)	-	-	Note3	
Color gamut	C	-	-	5	-	%	Remark1 Note3	
Response time	Ton	White to black	90% → 10%	-	14	28	ms	Note6
	Toff	Black to white	10% → 90%	-	25	50		

Remark : Against NTSC color space

< Backlight turning on >

Note1

Parameter	Symbol	Condition	Min.	Typ.	Max.	Unit	Remarks
Contrast ratio	CR	IL= 18mA	50	90	-	-	Note2, 4
Luminance	L	IL= 18mA	70	90	-	cd/m ²	Note4
Luminance uniformity	LU	Maximum luminance: 100%	60	70	-	%	Note5

☆

Reference data

Note1

Parameter	Symbol	Condition	Min.	Typ.	Max.	Unit	Remarks	
Chromaticity coordinates	W	White (x, y)	(0.27,0.28)	(0.32,0.33)	(0.37,0.38)	-	Remark2 Note4	
Color gamut	C	IL= 18mA	35	40	-	%	Remark1 Note4	
Response time	Ton	White to black	90% → 10%	-	14	28	ms	Note6
	Toff	Black to white	10% → 90%	-	25	50		

Remark1: Against NTSC color space

Remark2: The White chromaticity coordinates are deviated by the LED deviation in addition to color filter deviation. (See following figure.)

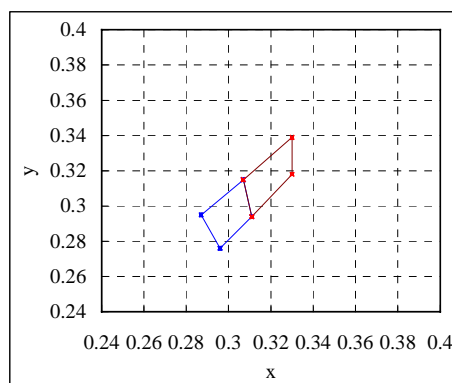

Chromaticity coordinates of LED

Note1: Ta = 25 °C, VCC= 3.0V, VDD=5.0V, Include touch panel

Note2: The contrast ratio is calculated by using the following formula.

$$\text{Contrast ratio (CR)} = \frac{\text{Reflection ratio (Luminance) with all pixels in "white"}}{\text{Reflection ratio (Luminance) with all pixels in "black"}}$$

Note3: Contrast ratio, Reflection ratio, Chromaticity coordinates and Color gamut are measured as follows.

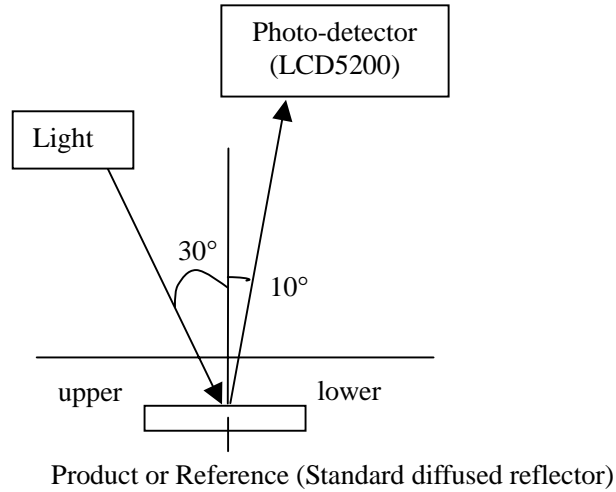

Note4: Contrast ratio, Luminance, Chromaticity coordinates and Color gamut are measured as follows.

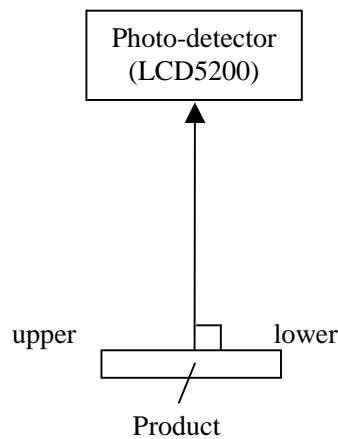

Note5: Luminance uniformity is measured at the following 9 points and is calculated by using the following formula.

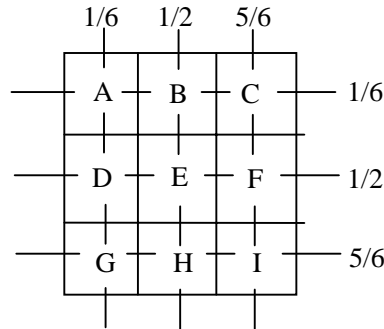

$$\text{Luminance uniformity (\%)} = \frac{\text{Minimum luminance from A to I}}{\text{Maximum luminance from A to I}} \times 100$$

Note6: Definitions of response times

Response time is measured, the luminance changes from "white" to "black", or "black" to "white" on the same screen point, by photo-detector. Ton is the time it takes the luminance change from 90% down to 10%. Also Toff is the time it takes the luminance change from 10% up to 90% (See the following diagram.).

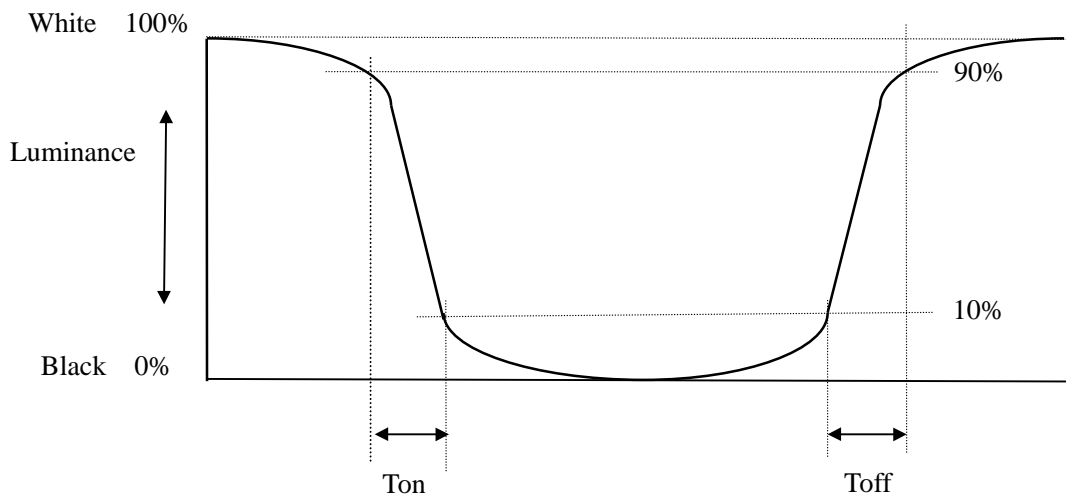

5. RELIABILITY TESTS

Test item	Condition	Judgement Note1
High temperature and humidity (Operation)	① $55 \pm 2^{\circ}\text{C}$, RH = 85%, 240 hours ② Display data is black.	No display malfunctions
Heat cycle (Operation)	① $-10 \pm 3^{\circ}\text{C}$...1 hour $55 \pm 3^{\circ}\text{C}$...1 hour ② 50 cycles, 4 hours/cycle ③ Display data is black.	
Thermal shock (Non operation)	① $-20 \pm 3^{\circ}\text{C}$...30 minutes $70 \pm 3^{\circ}\text{C}$...30 minutes ② 100 cycles, 1 hour/cycle ③ Temperature transition time is within 5 minutes.	
Low pressure (Non operation)	① 15 kPa ② $-20 \pm 3^{\circ}\text{C}$...24 hours ③ $70 \pm 3^{\circ}\text{C}$...24 hours	
Low pressure (Operation)	① 53.3 kPa ② $-10 \pm 3^{\circ}\text{C}$...24 hours ③ $55 \pm 3^{\circ}\text{C}$...24 hours	
ESD (Operation)	① 150pF, 150Ω, ±10kV ② 3 places on a panel surface Note2 ③ 10 times each places at 1 sec interval	
Dust (Operation)	① Sample dust: No. 15 (by JIS-Z8901) ② 15 seconds stir ③ 8 times repeat at 1 hour interval	
Vibration (Operation)	① 30 to 100Hz, 19.6m/s^2 ② 30 minute/cycle ③ X, Y, Z direction ④ 1 times each directions	No display malfunctions No physical damages
Mechanical shock (Non operation)	① 3920m/s^2 , 2.5ms ② ±X, ±Y, ±Z direction ③ 1 times each directions	

Note1: Display and appearance are checked under environmental conditions equivalent to the inspection conditions of defect specifications.

6. PRECAUTIONS

The following statements are very important, be sure to understand the following information.



This sign has the meaning that customer will be injured by himself, if customer has wrong operations.

(1) Handling of the product

- ① Take hold of both ends without touch the FPC when customer pulls out products (LCD modules) from the tray.
- ② Take the measures of electrostatic discharge such as earth band, ionic shower and so on, when customer deals with the product, because products may be damaged by electrostatic.
- ③  Since the LCD panel is made from fragile glass materials, impulse and pressure to the product must be avoided.
- ④ As the surface of touch panel is easily scratched, use a soft dry cloth without chemicals for cleaning.
- ⑤ Do not push-pull FPC while the product is working, because wrong power sequence may break down the product.
- ⑥ Put the product rear side down on a flat horizontal plane.
- ⑦ Handle the FPC with care.
- ⑧ When the product is operating, do not loose the logic signals. If any one or more of these signals were lost, the product would be damaged.
- ⑨ Flexing or adding pressure to the product will result in a non-uniformity image. When the product is mounted to customer chassis, evaluate the display condition carefully.
- ⑩ Do not fold the FPC. When folding the FPC, pattern disconnection may be caused. In case of bending FPC, the minimum curvature (R) must be more than 1.0 mm.

(2) Environment

- ① Do not operate or store in high temperature, high humidity, dewdrop atmosphere or corrosive gases. Keep the product on the tray in antistatic pouch in room temperature, because of avoidance for dusts and sunlight, if customer stores the product.
- ② In order to prevent dew condensation occurring by temperature difference, the product packing box must be opened after leave under the environment of an unpacking room temperature enough. Because a situation of dew condensation occurring is changed by the environmental temperature and humidity, evaluate the leaving time sufficiently. (Recommendation leaving time: 6 hour or more with packing state)
- ③ Do not operate in high magnetic field. Circuit boards may be broken down by it.
- ④ This product is not designed as radiation hardened.

(3) Characteristics

- ① Response time, luminance and color may be changed by ambient temperature.
- ② Do not display the fixed pattern for a long time because it may cause image sticking.
- ③ The LCD may be seemed luminance non-uniformity, flicker, vertical seam or small spot by display patterns.
- ④ Optical characteristics (e.g. luminance, display uniformity, etc.) gradually is going to change depending on operating time, because the product has LED backlight.

(4) Other

- ① Do not disassemble and/or reassemble the product.
- ② Pack the product with original shipping package, because of avoidance of some damages during transportation, when customer returns it to NEC for replacement and so on.

7. OUTLINE DRAWINGS

FRONT VIEW

REAR VIEW

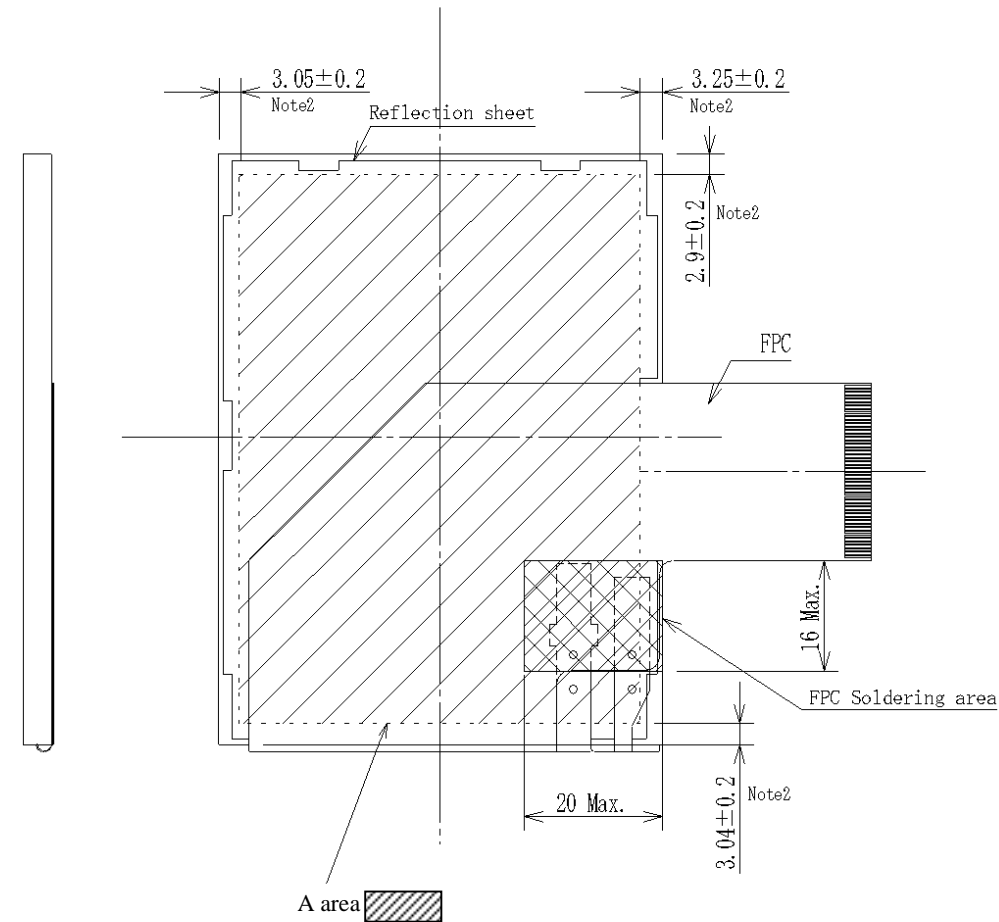
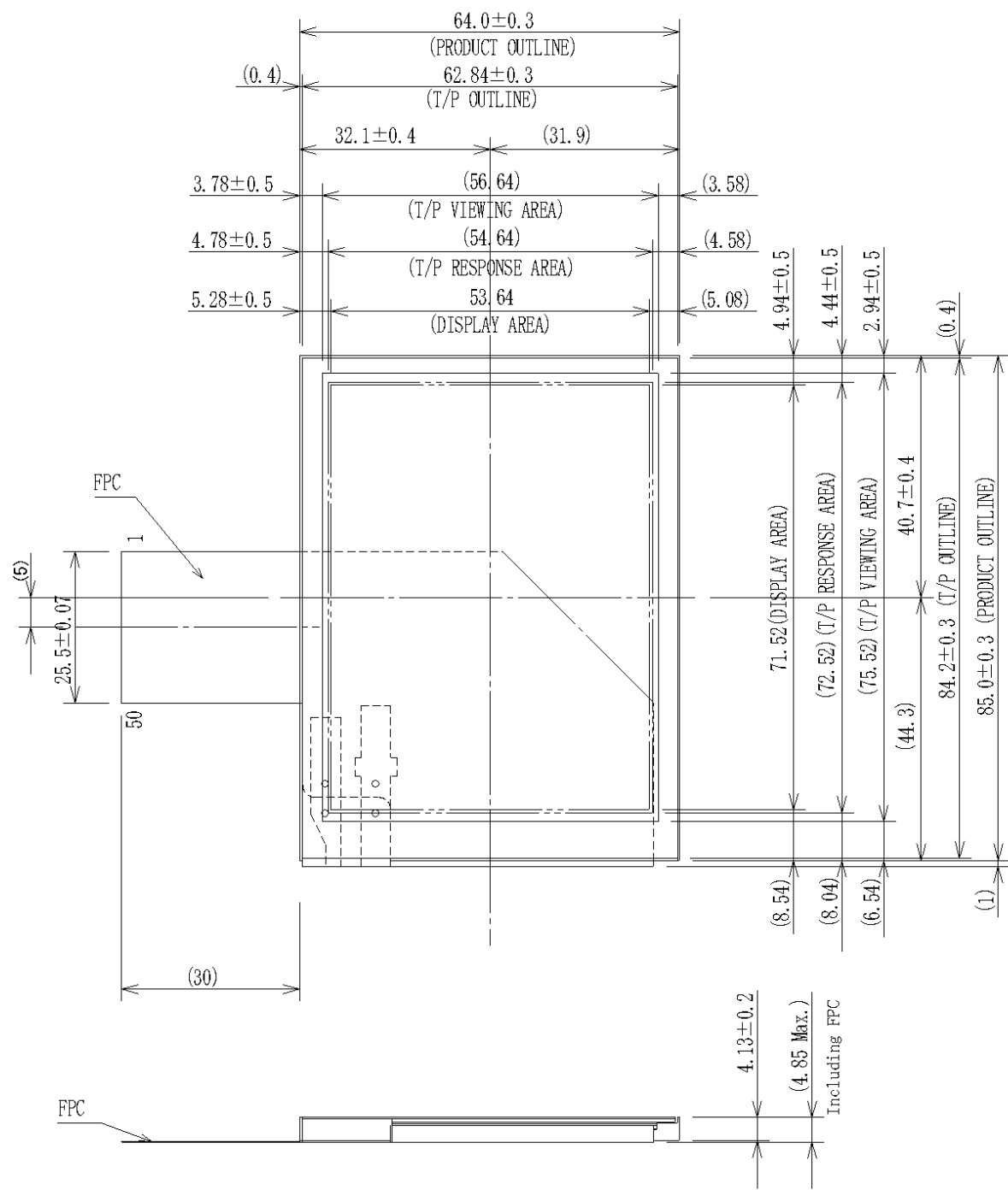

Pin No.	Symbol	Pin No.	Symbol
1	GND	26	D11
2	COM	27	D12
3	V0	28	D13
4	V1	29	D14
5	V2	30	D15
6	V3	31	D00
7	V4	32	D01
8	GAM	33	D02
9	VCOM	34	D03
10	N.C.	35	D04
11	INV	36	D05
12	POL	37	GND
13	STB	38	VDD
14	AP	39	VCK
15	VCC	40	VG OFF
16	HCK	41	VOE
17	HSP	42	VGON
18	GND	43	VSP
19	D20	44	GND
20	D21	45	YU
21	D22	46	XR
22	D23	47	YD
23	D24	48	XL
24	D25	49	CATHODE
25	D10	50	ANODE

Note1: The values in parentheses are for reference.

Note2: Frame width of product chassis

Note3: When installing the product to the customer equipment, do not apply undue stress to the A area, FPC and FPC Soldering area. If not, it may cause display un-uniformity or product breaking.

Unit: mm

8. RECOMMENDATION DESIGN OF FRONT BEZEL

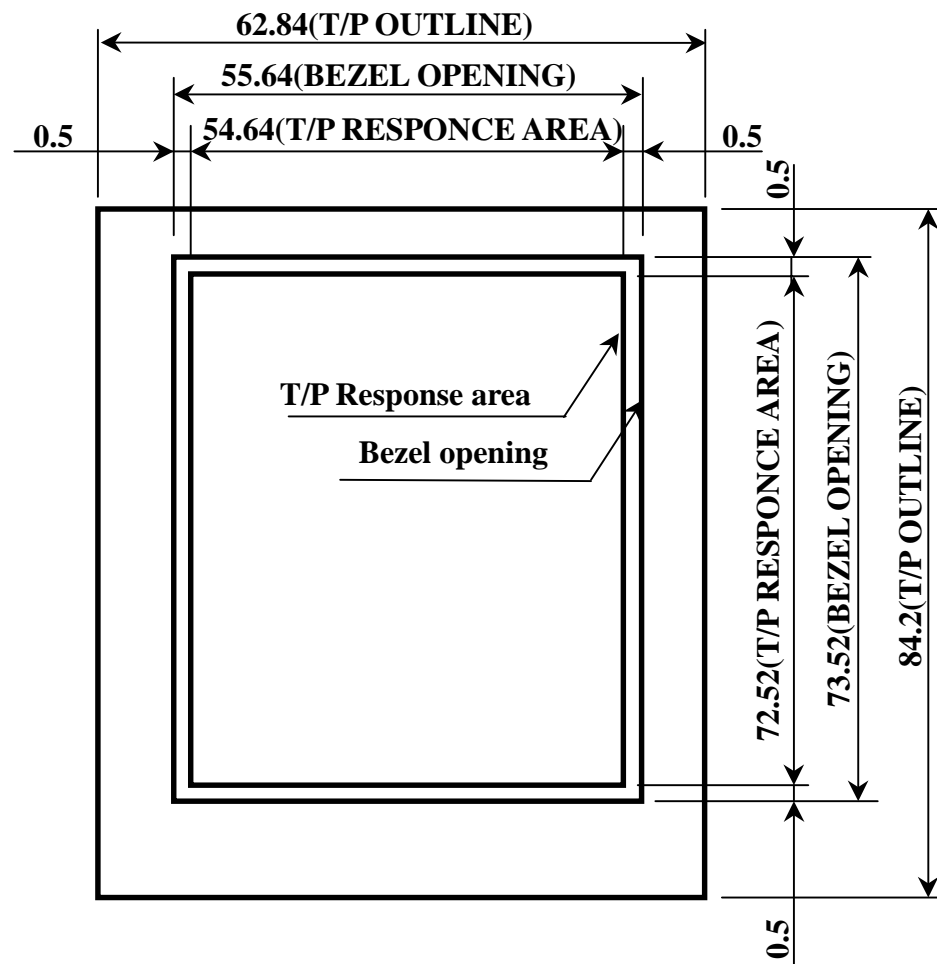
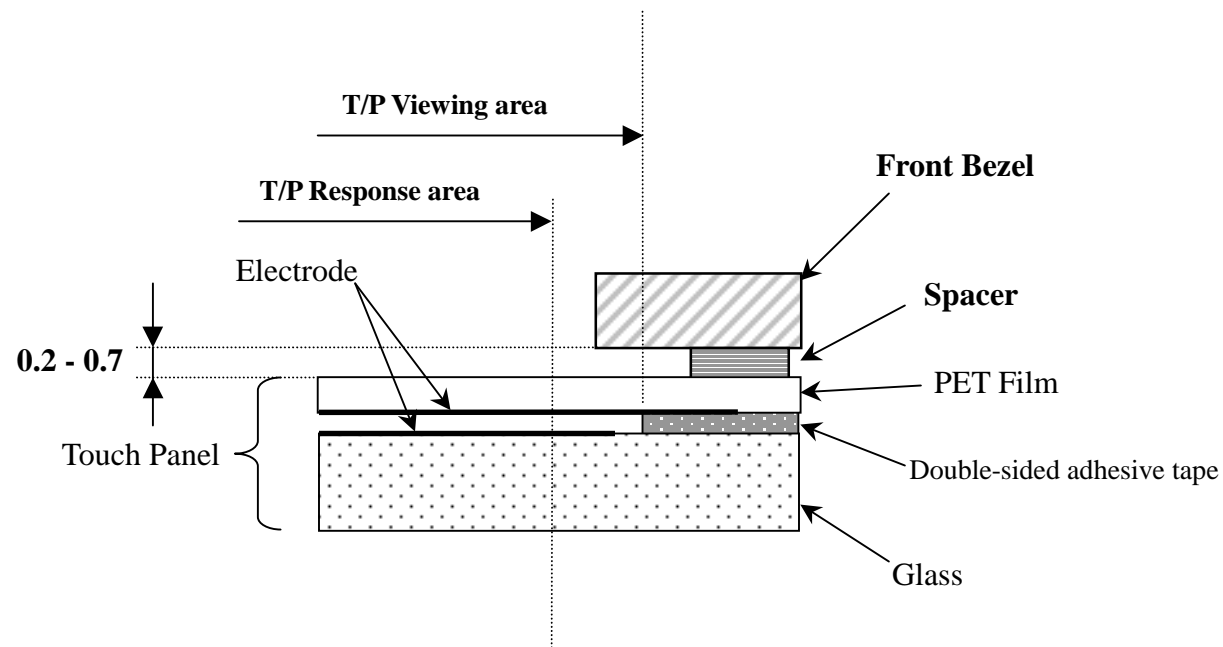

Front Bezel opening design

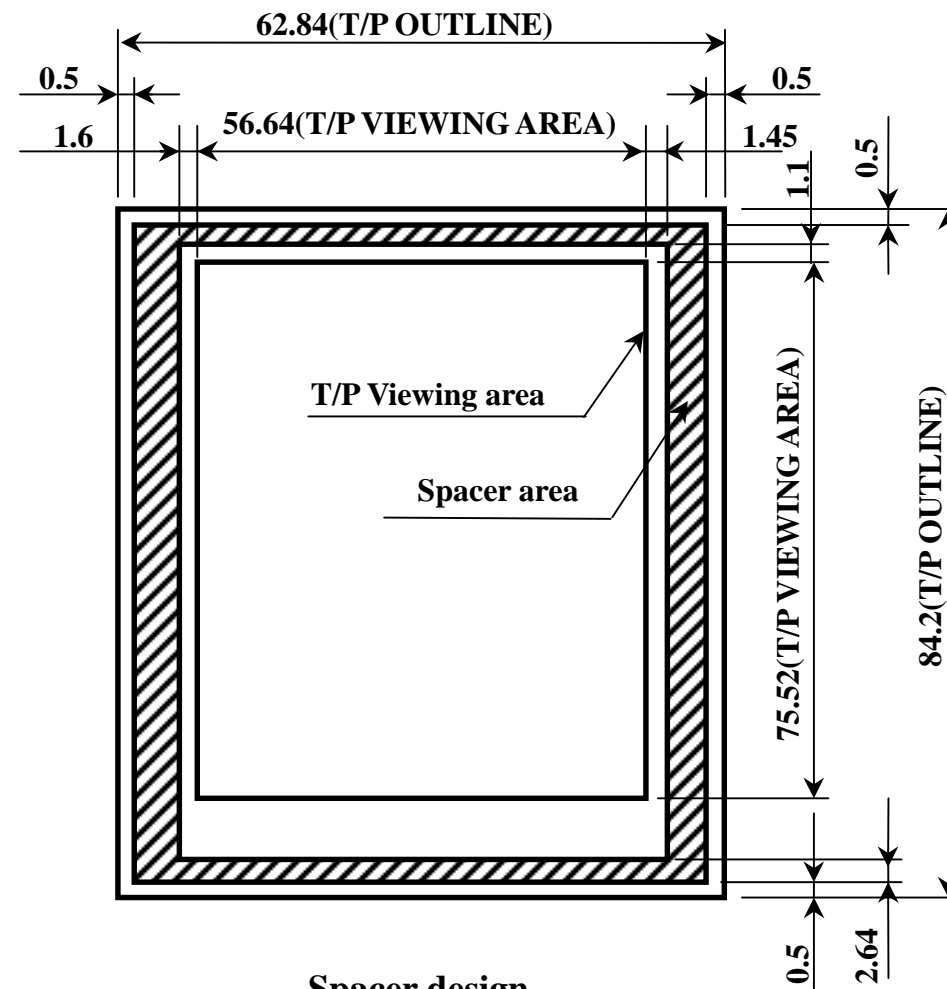

Spacer design

Design guidance for the front bezel & the spacer

1. **Front Bezel** opening design

- a. Please place the front bezel opening to maintain the operation by a stylus pen inside the T/P response area.
- b. The any pressures in the area between T/P response area and T/P viewing area is prohibited. Please use the appropriate material as the front bezel.

2. **Spacer** design

- a. Please put the spacer, a cushion, on the front bezel, do not use an adhesive tape to stick on the touch panel surface.
- b. Please position the spacer over the **Spacer area** to avoid a "short".

(Unit: mm)