

● Features :

1. 0.56 inch (14.20mm) Digit Height.
2. Continuous uniform segments.
3. Low power requirement.
4. Excellent characters appearance.
5. Solid state reliability.
6. Categorized for luminous intensity.
7. Direct drive common cathode.

● Description :

1. The BD-C51DRD is a 14.20mm(0.56") high dual digit seven segments display.
2. This product use super red chips, which are made from AlGaAs on GaAs substrate..
3. This product have a black face and white segments.
4. This product doesn't contain restriction substance, comply ROHS standard.

● Package Dimensions :

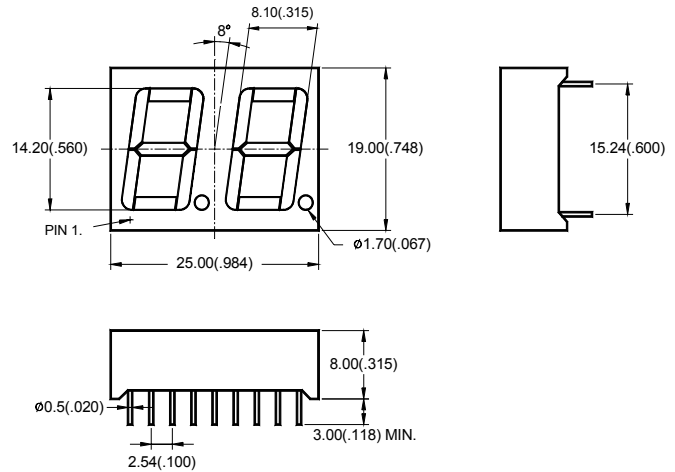

Notes:

1. All dimensions are in millimeters(inches).
2. Tolerance is $\pm 0.25\text{mm}(.01\text{'})$ unless otherwise specified.
3. Specifications are subject to change without notice.

● Internal Circuit Diagram :

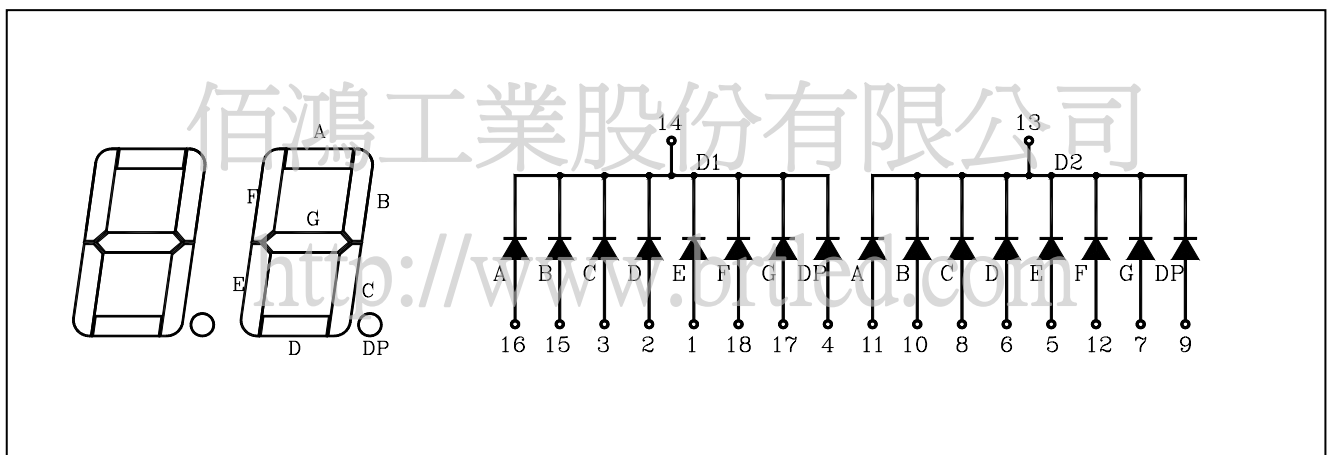

● **Absolute Maximum Ratings(Ta=25°C)**

| Parameter | Symbol | Rating | Unit |
|--|--------------------------------------|---------------------|------|
| Power Dissipation Per Segment | Pd | 80 | mW |
| Forward Current Per Segment | I _F | 30 | mA |
| Peak Forward Current Per Segment | I _{FP} (Duty 1/10, 1KHZ) | 150 | mA |
| Reverse Voltage Per Segment | V _R | 5 | V |
| Operating Temperature | Topr | -40°C~80°C | - |
| Storage Temperature | Tstg | -40°C~85°C | - |
| Soldering Temperature (1/16" From Body) | Tsol | 260°C For 5 Seconds | - |

● **Electrical And Optical Characteristics(Ta=25°C)**

| Parameter | Symbol | Condition | Min. | Typ. | Max. | Unit |
|--------------------------------|----------------|----------------------|------|------|------|------|
| Forward Voltage Per Segment | V _f | I _F =10mA | - | 1.7 | 2.5 | V |
| Luminous Intensity Per Segment | I _v | I _F =10mA | - | 7.5 | - | mcd |
| Reverse Current Per Segment | I _R | V _R =5V | - | - | 100 | μA |
| Peak Wave Length | λ _p | I _F =10mA | - | 660 | - | nm |
| Dominant Wave Length | λ _d | I _F =10mA | 638 | - | 648 | nm |
| Spectral Line Half-width | Δλ | I _F =10mA | - | 20 | - | nm |

<http://www.brtled.com>

● Typical Electro-Optical Characteristics Curves

(25°C Ambient Temperature Unless Otherwise Noted)

Fig.1 Relative Radiant Intensity VS. Wavelength

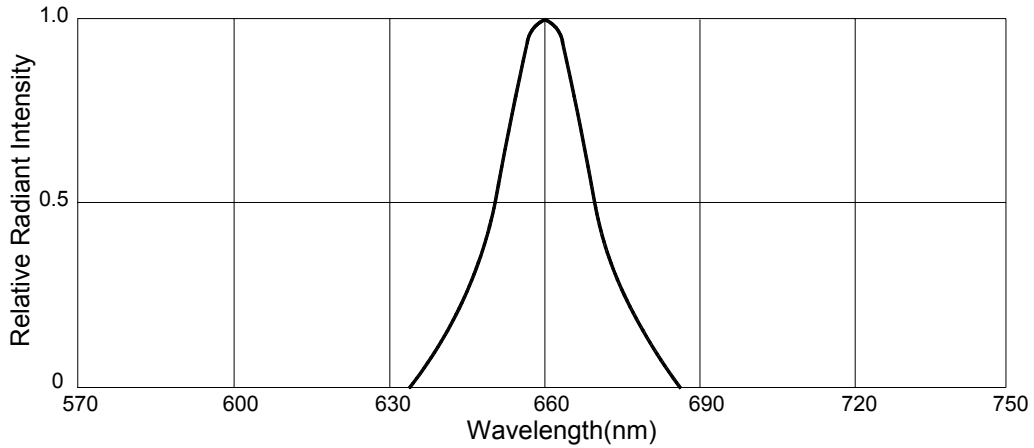

Fig.2 Forward Current VS. Forward Voltage

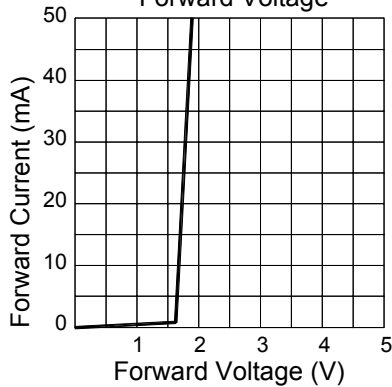

Fig.3 Relative Luminous Intensity VS. Ambient Temperature

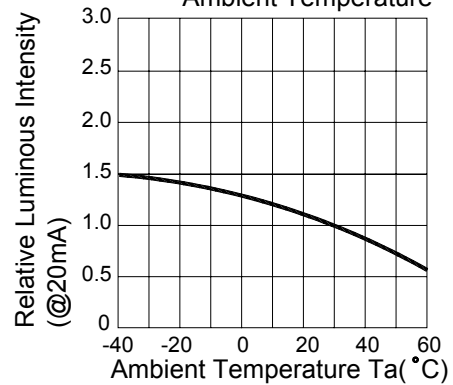

Fig.4 Relative Luminous Intensity VS. Forward Current

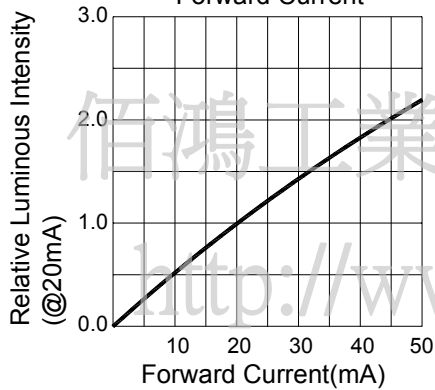

Fig.5 Forward Current Derating Curve VS. Ambient Temperature

