



*The Best USB Audio Single Chip for
Stereo Digital Control Speakers Application*

CM103+ 16-Bit Stereo USB Audio Controller

Datasheet Version 1.01

C-MEDIA ELECTRONICS INC.

TEL: 886-2-8773-1100 FAX: 886-2-8773-2211

6F, 100, Sec. 4, Civil Boulevard, Taipei, Taiwan 106, R.O.C.

For detailed product information, please contact sales@cmedia.com.tw



NOTICES

THIS DOCUMENT IS PROVIDED "AS IS" WITH NO WARRANTIES WHATSOEVER, INCLUDING ANY WARRANTY OF MERCHANTABILITY, NONINFRINGEMENT, FITNESS FOR ANY PARTICULAR PURPOSE, OR ANY WARRANTY OTHERWISE ARISING OUT OF ANY PROPOSAL, DOCUMENT OR SAMPLE.

ALL RIGHTS RESERVED. NO PART OF THIS DOCUMENT MAY BE REPRODUCED OR TRANSMITTED IN ANY FORM OR BY ANY MEANS, ELECTRONIC OR MECHANICAL, INCLUDING INFORMATION STORAGE AND RETRIEVAL SYSTEMS, WITHOUT PERMISSION IN WRITING FROM C-MEDIA ELECTRONICS, INC.

COPYRIGHT

Copyright (c) 2005-2007 C-Media Electronics Inc.

All rights reserved. All content included on this document, such as text, graphics, logos, button icons, images, audio clips, digital downloads, data compilations, and software, is either the exclusive property of C-Media Electronics Inc., its affiliates (collectively, "C-Media"), its content suppliers, or its licensors and protected by Republic of China and international copyright laws.

TRADEMARKS

C-Media, the C-Media Logo, Xear 3D, Xear 3D Logo, Speaker Shifter, Smart Jack, and Smart Audio Jack are trademarks of C-Media Electronics Inc. in Republic of China and/or other countries. All other brand and product names listed are trademarks or registered trademarks of their respective holders and are hereby recognized as such.

****C-Media reserves the right to modify the specifications without further notice****



TABLE OF CONTENTS

1. DESCRIPTIONS AND OVERVIEW	5
2. FEATURES	5
3. PIN DESCRIPTIONS	7
3.1 PIN ASSIGNMENT BY PIN NUMBER	7
3.2 PIN-OUT DIAGRAM	7
3.3 PIN SIGNAL DESCRIPTIONS	8
4. BLOCK DIAGRAM	11
5. ORDERING INFORMATION	12
6. FUNCTION DESCRIPTIONS	13
6.1 USB INTERFACE	13
6.1.1 DEVICE DESCRIPTOR	13
6.1.2 CONFIGURATION DESCRIPTOR	14
6.1.3 USB AUDIO TOPOLOGY DIAGRAM	14
6.2 EEPROM (93C46) CONTENT FORMAT	15
6.3 HID FEATURE	16
6.3.1 WHAT'S HID	16
6.3.2 HID DESCRIPTOR	16
6.4 DYNAMIC RANGE CONTROL (DRC)	18
7. ELECTRICAL CHARACTERISTICS	19
7.1 ABSOLUTE MAXIMUM RATING	19
7.2 OPERATION CONDITIONS	19
7.3 SPERKER IMPEDANCE VS. OUTPUT POWER CONSUMPTION	20
7.4 AUDIO PERFORMANCE	20



8. AUDIO PERFORMANCE CURVES	22
8.1 FREQUENCY RESPONSE (10K OHM LOADING)	22
8.1.1 FREQUENCY RESPONSE @ 44.1 KS/SEC	22
8.1.2 FREQUENCY RESPONSE @ 48 KS/SEC	22
8.2 PASSBAND RIPPLE (10K OHM LOADING)	23
8.2.1 PASSBAND RIPPLE @ 44.1 KS/SEC	23
8.2.2 PASSBAND RIPPLE @ 48 KS/SEC	23
9. REFERENCE APPLICATION CIRCUIT	24
10. REFERENCE	25



1. DESCRIPTIONS AND OVERVIEW

CM103+ is a highly integrated single chip for USB digital control speaker application. It is a truly plug-and-play USB audio device and provided high quality digital sound playback. This one chip solution not only embedded USB transceiver, ADC, DAC component but also integrated digital control power amplifier function for USB digital sound application. Minimum external components are needed for building a high-end 2CH USB speaker system, which makes CM103+ a simple and very cost-effective solution. Since no driver is necessary for audio playback on all major OS.

The innovation technology DRC feature was integrated on CM103+. This Dynamic Range Control function can support high efficiency volume output to get loudness sound effect similar D class amplifier capability. Vender can just using single chip to saving external amplifier component and getting a better listening experience when listen to a music source with wide dynamic range.

Customers can use an EEPROM to define vendor specific VID / PID / Product String, and even special hardware configuration. More flexible and customized design is possible with GPIO pin, which is accessible by USB vendor specific request. For energy saving, USB suspend mode and resume is supported by CM103+. With power amplifier enable pin and volume control VR input pin, a traditional speaker front panel design can be built. Moreover, CM103+ support USB standard HID Interface which provide Vol_up / Vol_dn / Play_mute Buttons and Rotary Encoder for pure digital volume control.

2. FEATURES

- USB 2.0 Full Speed Compatible and USB IF certification
- USB Audio Devices Class Specification Ver1.0 Compatible
- USB Bus Powered 500mA, without External Power Supply
- High performance 16-Bit Stereo, 48 / 44.1 KHz Sampling Rate for Audio Playback
- S/PDIF Output Interface
- Embedded USB Transceiver
- Embedded High Performance 16-Bit Audio DAC



- Embedded Digital Control Power Amplifier for Speaker Driving
- Support Power Amplifier Enable / Disable Control Pin
- Support Dynamic Range Control (DRC) Feature to Provide a Better Listen Experience
- Embedded Power-On-Reset Block
- Embedded 5V to 3.3V Regulator with Voltage Level Detector for Single 5V External Power Supply
- Embedded Temperature Protection Circuit
- Embedded X2 Modulation for Higher Audio Quality
- Embedded Anti-Pop Circuit with Internal Feedback Structure
- Single 12MHz Crystal Input with Embedded PLL
- Isochronous Transfer using Adaptive Synchronization with Internal PLL
- External EEPROM Interface for Vendor Specific VID / PID / Product String
- EEPROM Read / Write Function via Vendor Specific Request for Mass Production Convenience
- Analog Volume Control Input with Simple External VR Circuit
- Digital Volume Control Input with Digital Rotary Encoder or Vol_up / Vol_dn / Play_mute Bottoms
- Vol_up / Vol_dn / Play_mute Pins and Digital Rotary Encoder Interface Support USB HID Devices Class Ver1.11 for Host Volume Control Synchronization
- Supports USB Suspend / Resume Mode and Remote Wakeup with Digital Volume Control Pins
- LED Indicator Pin During Playback
- 1 GPIO pin for Application Specific Usage
- 3.3V I/O with 5V Tolerance
- Dolby® Digital and DTS Audio Streaming via S/PDIF Output
- Compatible with Win 98SE / Win ME / Win 2000 / Win XP, and Mac OS 10.X without additional driver

3. PIN DESCRIPTIONS

3.1 PIN ASSIGNMENT BY PIN NUMBER

Pin #	Signal Name	Pin #	Signal Name	Pin #	Signal Name	Pin #	Signal Name
1	EESK	13	NC	25	AVDD	37	NC
2	DVDD5V	14	NC	26	AVDD	38	DRCEN
3	EECS	15	REGV	27	LOL	39	SPDIFO
4	EEDW	16	NC	28	LOL	40	PDSW
5	EEDR	17	USB_DP	29	LOL	41	PAEN
6	LEDO	18	NC	30	LOL	42	GPIO
7	MUTE	19	USB_DM	31	LOR	43	VOL_UP
8	DVDD5V	20	NC	32	LOR	44	VOL_DN
9	DVDD5V	21	DVSS	33	LOR	45	DVSS
10	VP	22	TEST	34	LOR	46	NC
11	VN	23	VREF	35	AVSS	47	XTAL_O
12	NC	24	VOLADJ	36	AVSS	48	XTAL_I

***Note:** -NC- means No-Connect

3.2 PIN-OUT DIAGRAM

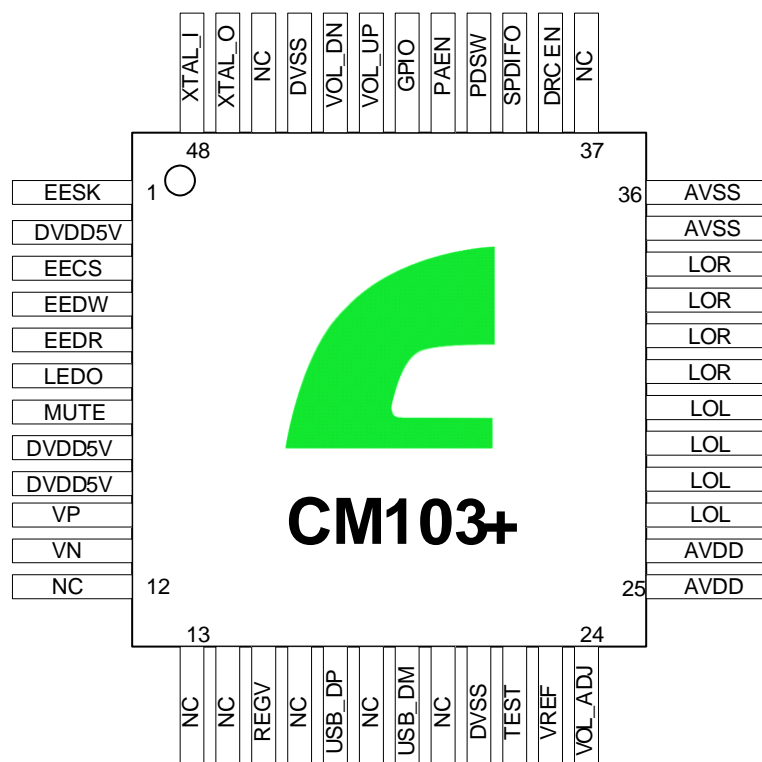

3.3 PIN SIGNAL DESCRIPTIONS

Pin #	Symbol	Type	Description
1	EESK	DO, 8mA, SR	EEPROM Interface Clock
2	DVDD5V	P	5V Power Supply for Digital Circuit
3	EECS	DO, 8mA, SR	EEPROM Interface Chip Select
4	EEDW	DO, 8mA, SR	EEPROM Interface Write to EEPROM
5	EEDR	DI, ST, PD, 5VT	EEPROM Interface Read from EEPROM
6	LEDO	DO, 8mA, SR	LED Indicator for Playback
7	MUTE	DI, ST, PU	Mute Pin (HID Standard)
8	DVDD5V	P	5V Power Supply
9	DVDD5V	P	5V Power Supply
10	VP	DI, ST, PU	Digital Rotary Encoder Interface Pin A
11	VN	DI, ST, PU	Digital Rotary Encoder Interface Pin B
12	NC	-	No Connect
13	NC	-	No Connect
14	NC	-	No Connect
15	REGV	AO	Regulator output 3.3V
16	NC	-	No Connect
17	USB_DP	AIO	USB Data D+
18	NC	-	No Connect
19	USB_DM	AIO	USB Data D-
20	NC	-	No Connect
21	DVSS	P	Digital Ground
22	TEST	DI, ST, PD	Test Mode Select Pin, Pull-Down in normal Operation
23	VREF	AO	Connecting to External Decoupling Capacitor for Embedded Bandgap Circuit; 2.25V Output



CM103+

USB Stereo Audio Chip for Digital Speakers Application

24	VOLADJ	AI	Analog Volume Control Input from external VR circuit. 0 ~ 2.25V: +3dB / mute 3.5 ~ 5V: 0dB
25	AVDD	P	5V Power Supply for Analog Circuit
26	AVDD	P	5V Power Supply for Analog Circuit
27	LOL	AO	Line Out Left Channel
28	LOL	AO	Line Out Left Channel
29	LOL	AO	Line Out Left Channel
30	LOL	AO	Line Out Left Channel
31	LOR	AO	Line Out Right Channel
32	LOR	AO	Line Out Right Channel
33	LOR	AO	Line Out Right Channel
34	LOR	AO	Line Out Right Channel
35	AVSS	P	Analog Ground
36	AVSS	P	Analog Ground
37	NC	-	No Connect
38	DRCEN	DI	1:DRC ON (default) 0:DRC Off
39	SPDIFO	DO, 8mA, SR	S/PDIF Data Output
40	PDSW	DO, 8mA, SR	Power Down Switch Control Signal Output 1: Normal Mode 0: Power Down Mode (Suspend Mode)
41	PAEN	DI, ST	Power Amplifier Control Input, Connect to a Switch or Pull-High in Normal Operation. H: Enable Power Amplifier (Normal Mode) L: Disable Power Amplifier
42	GPIO	DIO, 8mA, ST, SR, PD	GPIO Pin, Controlled via Vendor Specific Command

Date: 09/25/2005

Version: 1.01



CM103+

USB Stereo Audio Chip for Digital Speakers Application

43	VOL_UP	DI, ST, PU	Volume Up Pin (HID Standard)
44	VOL_DN	DI, ST, PU	Volume Down Pin (HID Standard)
45	DVSS	P	Digital Ground
46	NC	-	No Connect
47	XTAL_O	AO	Output Pin for 12MHz Oscillator
48	XTAL_I	AI	Input Pin for 12MHz Oscillator

***Note:** **DI / DO / DIO** – Digital Input / Output / Bi-Directional Pad

AI / AO / AIO – Analog Input / Output / Bi-Directional Pad

P – Power Pin

SR – Slew Rate Control

ST – Schmitt Trigger

PD / PU – Pull Down / Pull Up

5VT – 5 Volt Tolerant (3.3V Pad)

4. BLOCK DIAGRAM

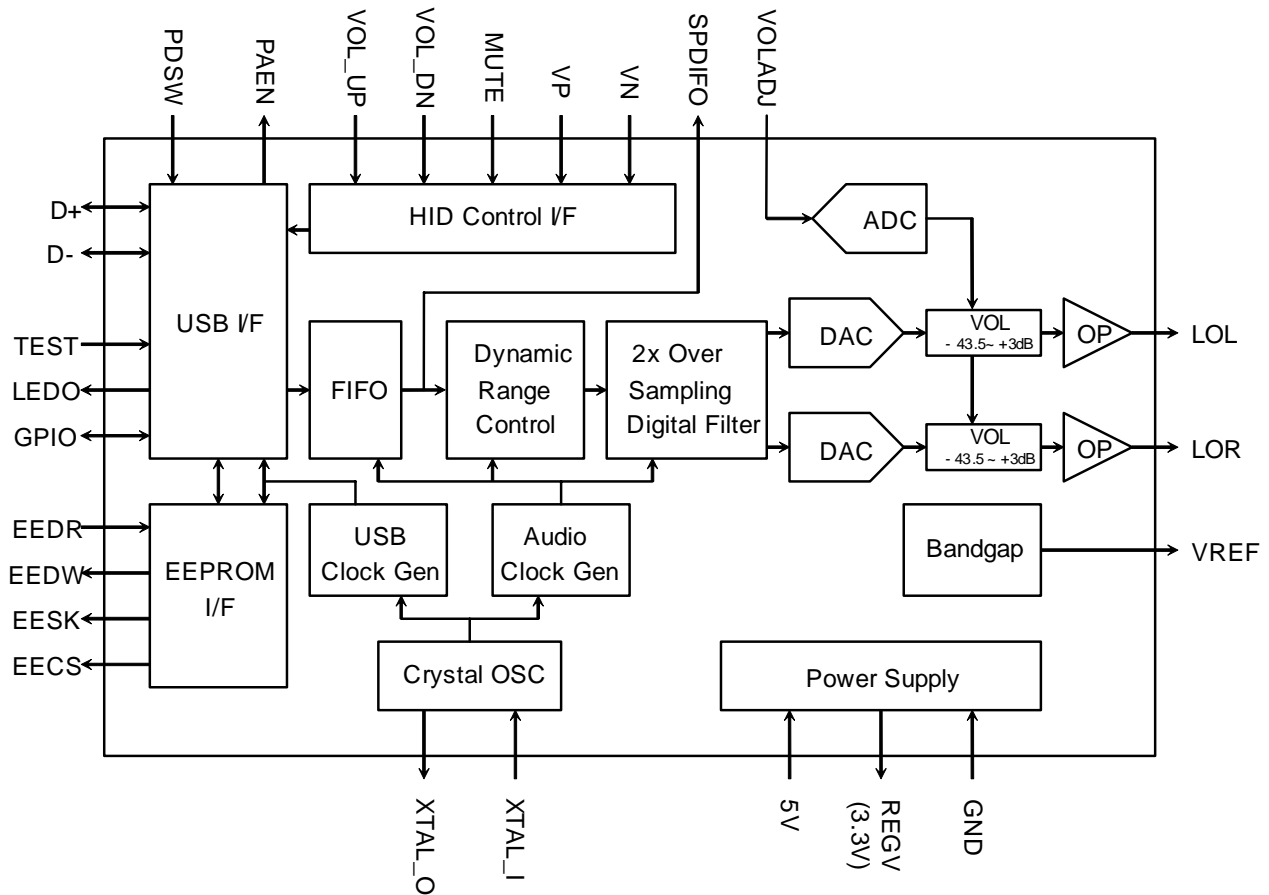

Block Diagram Of CM103+

5. ORDERING INFORMATION

Model Number	Package	Operating Ambient Temperature	Supply Range
CM103+	48-Pin LQFP 7mm×7mm×1.4mm (Plastic)	0°C to +70°C	DVdd = 5V, AVdd = 5V

48-Lead Thin Plastic Quad Flatpack (LQFP)

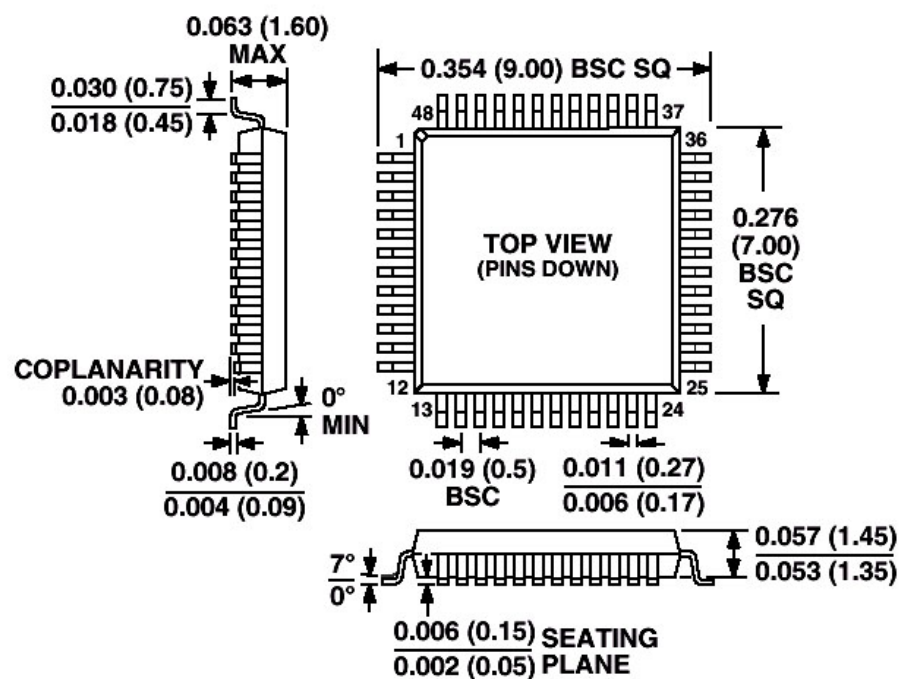

Outline Dimensions *Dimensions shown in inches and (mm)

6. FUNCTION DESCRIPTIONS

6.1 USB INTERFACE

6.1.1 DEVICE DESCRIPTOR

Offset	Field	Size	Value (Hex)	Description
0	bLength	1	12	Total 18 Bytes
1	bDescriptorType	1	01	Device Descriptor
2	bcdUSB	2	0110	USB 1.1 compliant.
4	bDeviceClass	1	00	
5	bDeviceSubClass	1	00	
6	bDeviceProtocol	1	00	
7	bMaxPacketSize0	1	08	Endpoint Zero Size = 8 bytes
8	idVendor	2	0D8C	Vendor ID
10	idProduct	2	0104	Product ID
12	bcdDevice	2	0010	Device Release Number
14	iManufacturer	1	01	Index of string descriptor describing manufacturer -> "C-Media INC."
15	iProduct	1	02	Index of string descriptor describing product -> "C-Media USB Audio"
16	iSerialNumber	1	00	Index of string descriptor describing the device's serial number
17	bNumConfigurations	1	01	Configurations number = 1

6.1.2 CONFIGURATION DESCRIPTOR

Offset	Field	Size	Value (Hex)	Description
0	bLength	1	09	Total 9 Bytes
1	bDescriptorType	1	02	Configuration Descriptor
2	wTotalLength	2	008D	Total length of data returned for this configuration.
4	bNumInterfaces	1	03	Number of interfaces supported by this Configuration.
5	bConfigurationValue	1	01	
6	iConfiguration	1	00	
7	bmAttributes	1	80	Self-powered without Remote Wakeup
8	bMaxPower	2	FA	Maximum power consumption of the USB. 0xFA=500 mA

6.1.3 USB AUDIO TOPOLOGY DIAGRAM

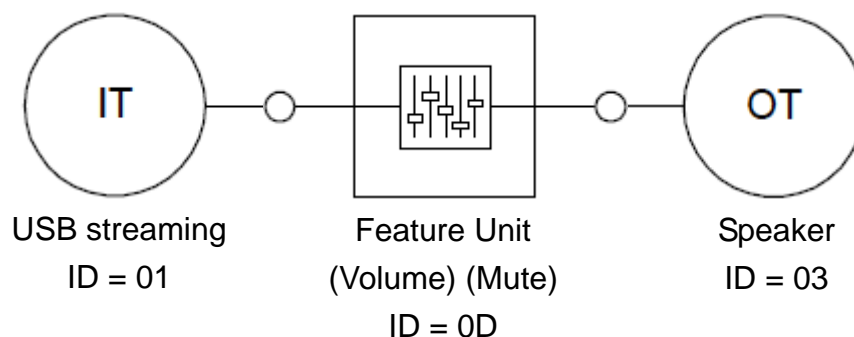

6.2 EEPROM (93C46) CONTENT FORMAT

CM103+ supports four-wire serial EEPROM interface. When an external serial EEPROM is detected, Vendor ID, Product ID, and Product String reported within Device Descriptor will be derived from the content of serial EEPROM. The setting values of serial EEPROM is shown below:

Address	Contents
00	0x434D (*Note1)
01	Vender ID
02	Product ID
03	String1, String0
04	String3, String2
05	String5, String4
06	String7, String6
07	String9, String8
08	String11, String10
09	String13, String12
10	String15, String14
11	String17, String16
12	String19, String18
13	String21, String20
14	String23, String22
15	Bit 0: DRC Enable / Disable
16~63	--

***Note:** The first word of the EEPROM is a magic code. Only when it matches, the IC will regard the serial EEPROM valid.



6.3 HID FEATURE

HID feature is provided by CM103+ so user setting to Volume-Up, Volume-Down, Playback-Mute button pin, and the Digital-Rotary-Encoder for Volume Control is reported to the host to synchronize host side setting.

6.3.1 WHAT'S HID

USB protocols can configure devices at startup or when they are plugged in at run time. These devices are broken into various device classes. Each device class defines the common behavior and protocols for devices that serve similar functions. The HID (Human Interface Device) class is one of the device classes.

The HID class consists primarily of devices that are used by humans to control the operation of computer systems. Typical examples of HID class devices include:

- Keyboards and pointing devices, for example: mouse, trackballs, and joysticks.
- Front-panel controls, for example: knobs, switches, buttons, and sliders.
- Controls that might be found on devices such as VCR remote controls, games or simulation devices, for example: data gloves, throttles, and steering wheels.
- Devices that may not require human interaction but provide data in a similar format to HID class devices, for example: bar-code readers, thermometers, or voltmeters.

6.3.2 HID DESCRIPTOR

HID Interface Descriptor

Offset	Field	Size	Value (Hex)	Description
0	bLength	1	09	Size of this descriptor: 9 byte
1	bDescriptorType	1	04	INTERFACE descriptor type
2	bInterfaceNumber	1	02	Number of Interface
3	bAlternateSetting	1	00	alternate 0

**CM103+****USB Stereo Audio Chip for Digital Speakers Application**

4	bNumEndpoints	1	01	Number of endpoints used by this Interface: 1
5	bInterfaceClass	1	03	HID Interface Class
6	bInterfaceSubClass	1	00	No Subclass
7	bInterfaceProtocol	1	00	Must be set to 0
8	iInterface	1	00	Index of a string descriptor that describes this interface.

HID Descriptor

Offset	Field	Size	Value (Hex)	Description
0	bLength	1	09	Total 9 Bytes
1	bDescriptorType	1	21	HID Descriptor Type
2	bcdHID	2	0100	HID class version 1.00
4	bCountryCode	1	00	
5	bNumDescriptors	1	01	
6	bDescriptorType	1	22	Report Descriptor
7	wDescriptorLength	2	002A	Numeric expression that is the total size of the optional descriptor

Interrupt IN Endpoint Descriptor

Offset	Field	Size	Value (Hex)	Description
0	bLength	1	07	Total 7 Bytes
1	bDescriptorType	1	05	ENDPOINT Descriptor Type
2	bEndpointAddress	1	81	IN Endpoint Endpoint number = 3
3	bmAttributes	1	03	Interrupt endpoint type
4	wMaxPacketSize	2	0003	Maximum packet size: 4 bytes
6	bInterval	1	04	Interrupt Interval: 4ms

6.4 DYNAMIC RANGE CONTROL (DRC)

CM103+ include a new feature called Dynamic Range Control (DRC), and with a default ON setting (Users can still turn it off within the Windows audio advance control panel)

Dynamic range is defined as the difference, in decibels (dB), between the loudest and quietest sounds in any particular piece of audio content. Classical music is a good example, with ranges from piano (soft) to forte to FFF (for extremely loud). Movies also typically have a wide dynamic range, which may cause you to have to turn the volume up and down as scenes change. For example, when watching a movie at home, you may be forced to turn up volume to hear the dialog in a quiet scene, and then quickly turn it down again during a car chase scene that follows. In this way, there may be times in a home theater environment when it would be useful to be able to control the dynamic range.

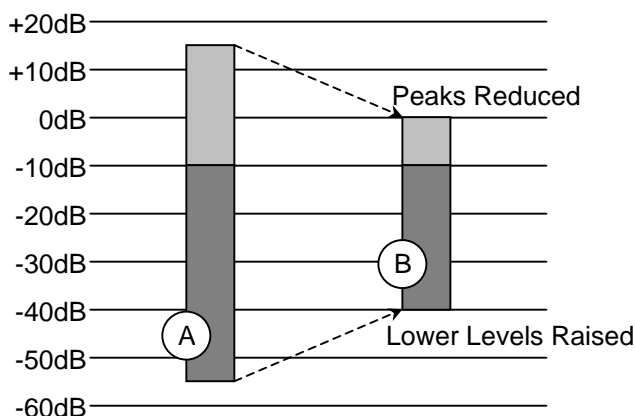

With Dynamic Range Control enabled, the full dynamic range (A) of the program is reduced (B).

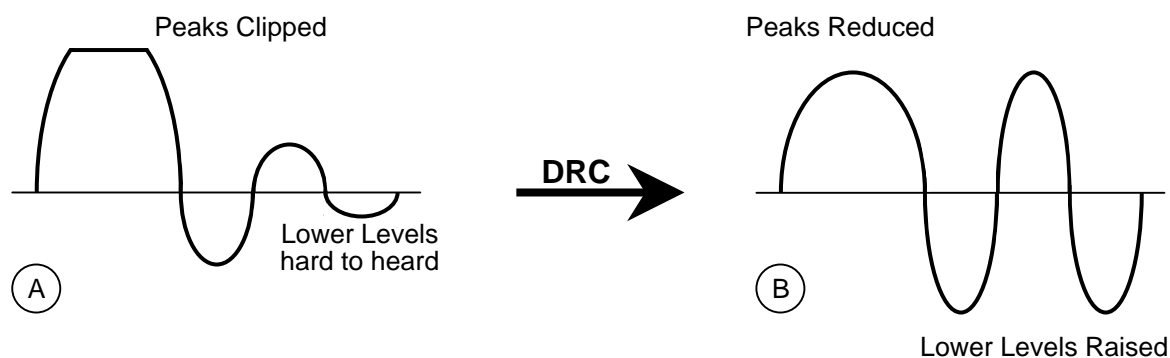

7. ELECTRICAL CHARACTERISTICS

7.1 ABSOLUTE MAXIMUM RATING

Symbol	Parameter	Value	Unit
Dvmin	Min Digital Supply Voltage	- 0.3	V
Dvmax	Max Digital Supply Voltage	+ 6	V
Avmin	Min Analog Supply Voltage	- 0.3	V
Avmax	Max Analog Supply Voltage	+ 6	V
Dvinout	Voltage on any Digital Input or Output Pin	-0.3 to +5.5	V
Avinout	Voltage on any Analog Input or Output Pin	-0.3 to +5.5	V
T _{stg}	Storage Temperature Range	-40 to +125	°C
ESD (HBM)	ESD Human Body Mode	2000	V
ESD (MM)	ESD Machine Mode	200	V
Latchup	Latch Up Test	200	mA

7.2 OPERATION CONDITIONS

	Min	Typ	Max	Unit
Analog Supply Voltage	4.5	5.0	5.5	V
Digital Supply Voltage	4.5	5.0	5.5	V
Total Power Consumption	-	-	500	mA
Suspend Mode Power Consumption	-	-	320	uA
Operating ambient temperature	0	-	70	°C

7.3 SPERKER IMPEDANCE VS. OUTPUT POWER (PER CHANNEL)

Items	Loading (Ohm)	4 Ohm	8 Ohm	32 Ohm	10K Ohm
Vpp		3.14	3.4	3.635	3.722
Vrms		1.11	1.202	1.285	1.316
W(rms/sin wave)		308 mW	181 mW	52 mW	0.17 mW
W(rms/square wave)		616 mW	361 mW	103 mW	0.35 mW
W(PMPO)		2460 mW	1450 mW	410 mW	1 mW

***Note1:** Test Condition @ 25°C, 5 Volt +/- 10%, 1KHz Sin Wave

***Note2:** Typical Output with THD+N < 1%; Maximal Output with THD+N < 10%

7.4 AUDIO PERFORMANCE

	Min	Typ	Max	Unit
Resolution	--	16	--	Bits
Frequency response @ 48KHz	20	--	20K	Hz
Frequency Response @ 44.1KHz	20	--	20K	Hz
Passband Ripple @ 48 KHz	40	--	9.6K	Hz
Passband Ripple @ 44.1 KHz	40	--	8.8K	Hz
DAC (10K Ohm Loading)				
SNR	--	97.75	--	dB
Dynamic Range	--	96.27	--	dB
THD + N	--	-67.97	--	dB
Output Voltage (rms)	-	1.316	-	Vrms

**CM103+****USB Stereo Audio Chip for Digital Speakers Application**

DAC (32 Ohm Loading)				
SNR	--	97.68	--	dB
Dynamic Range	--	95.99	--	dB
THD + N	--	-57.82	--	dB
Output Voltage (rms)	-	1.285	-	Vrms
DAC (8 Ohm Loading)				
SNR	--	97.67	--	dB
Dynamic Range	--	96.03	--	dB
THD + N	--	-53.28	--	dB
Output Voltage (rms)	-	1.202	-	Vrms
DAC (4 Ohm Loading)				
SNR	--	97.45	--	dB
Dynamic Range	--	95.89	--	dB
THD + N	--	-52.76	--	dB
Output Voltage (rms)	-	1.11	-	Vrms



CM103+
USB Stereo Audio Chip for Digital Speakers Application

8. AUDIO PERFORMANCE CURVES

8.1 FREQUENCY RESPONSE (10K OHM LOADING)

8.1.1 FREQUENCY RESPONSE @ 44.1 KS/SEC

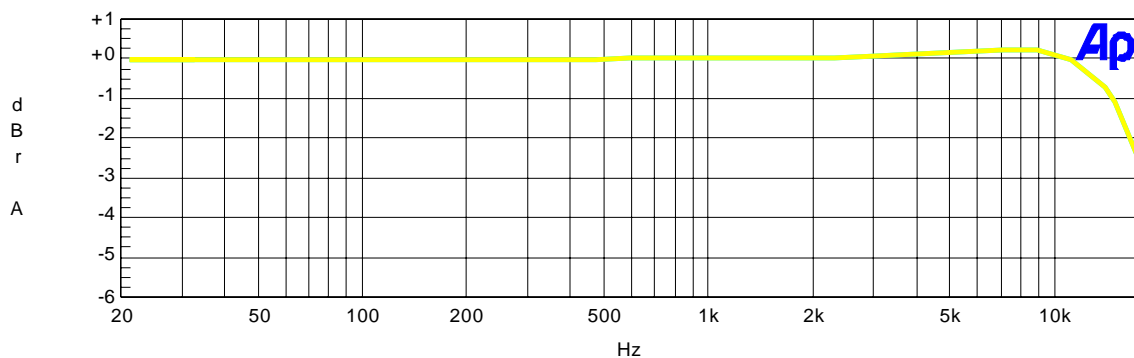
C-MEDIA Digital Playback (PC-D-A) for Line Output Frequency Response 05/31/05 14:10:33



Sweep	Trace	Color	Line Style	Thick	Data	Axis	Comment
1	1	Cyan	Solid	3	Fasttest.Ch.1 Ampl!Normalize	Left	
1	2	Yellow	Solid	3	Fasttest.Ch.2 Ampl!Normalize	Left	

WL-Multitone-44k.at2c

8.1.2 FREQUENCY RESPONSE @ 48 KS/SEC

C-MEDIA Digital Playback (PC-D-A) for Line Output Frequency Response 05/31/05 14:07:22

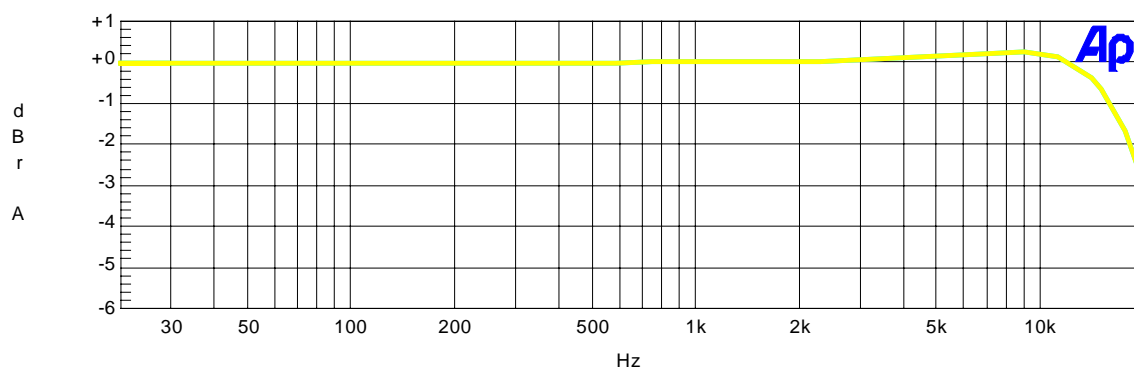

Sweep	Trace	Color	Line Style	Thick	Data	Axis	Comment
1	1	Cyan	Solid	3	Fasttest.Ch.1 Ampl!Normalize	Left	
1	2	Yellow	Solid	3	Fasttest.Ch.2 Ampl!Normalize	Left	

WL-Multitone-48k.at2c

Date: 09/25/2005

Version: 1.01

CM103+
USB Stereo Audio Chip for Digital Speakers Application

8.2 PASSBAND RIPPLE (10K OHM LOADING)

8.2.1 PASSBAND RIPPLE @ 44.1 KS/SEC

C-MEDIA Digital Playback (PC-D-A) for Line Output Passband 05/31/05 14:11:07
Ripple @44.1ks/sec

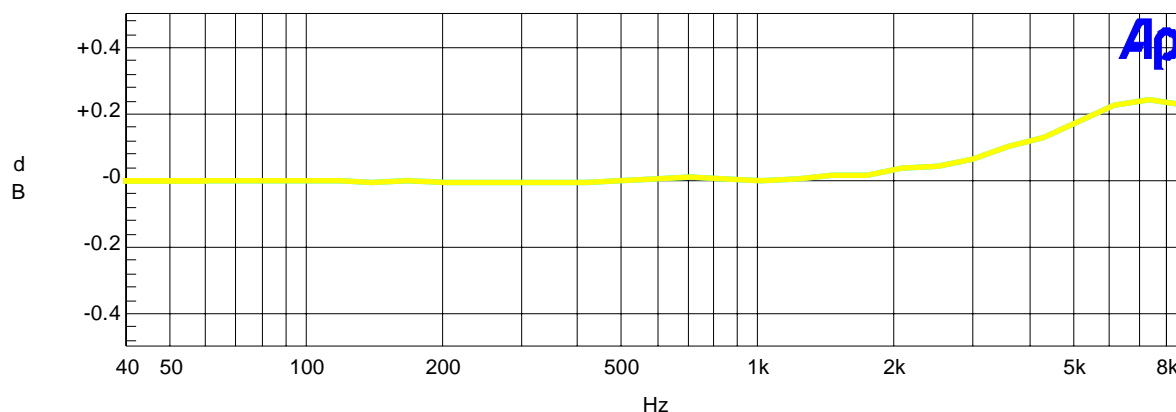

Sweep	Trace	Color	Line Style	Thick	Data	Axis	Comment
1	1	Cyan	Solid	3	Fasttest.Ch.1 Ampl!Normalize	Left	
1	2	Yellow	Solid	3	Fasttest.Ch.2 Ampl!Normalize	Left	

WL-PassbandRipple-M44k.at2c

8.2.2 PASSBAND RIPPLE @ 48 KS/SEC

C-MEDIA Digital Playback (PC-D-A) for Line Output Passband 05/31/05 14:09:08
Ripple @48ks/sec

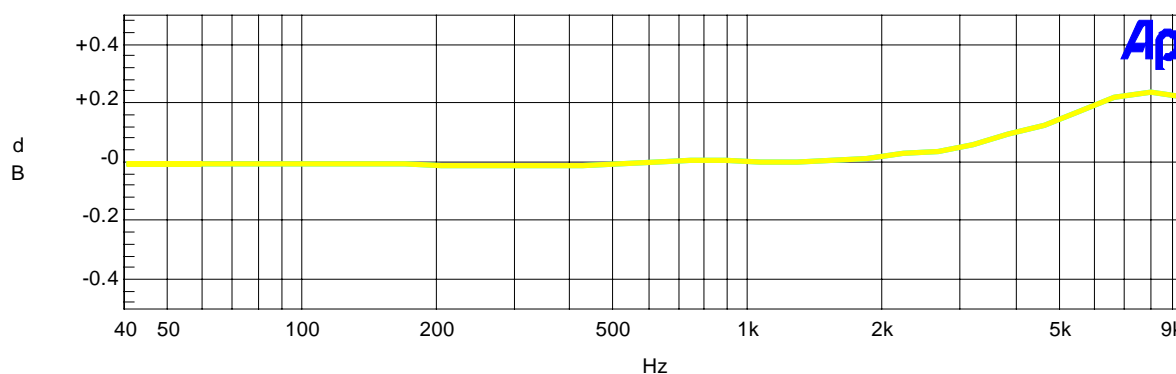

Sweep	Trace	Color	Line Style	Thick	Data	Axis	Comment
1	1	Cyan	Solid	3	Fasttest.Ch.1 Ampl!Normalize	Left	
1	2	Yellow	Solid	3	Fasttest.Ch.2 Ampl!Normalize	Left	

WL-PassbandRipple-M48k.at2c

Date: 09/25/2005

Version: 1.01

9. REFERENCE APPLICATION CIRCUIT

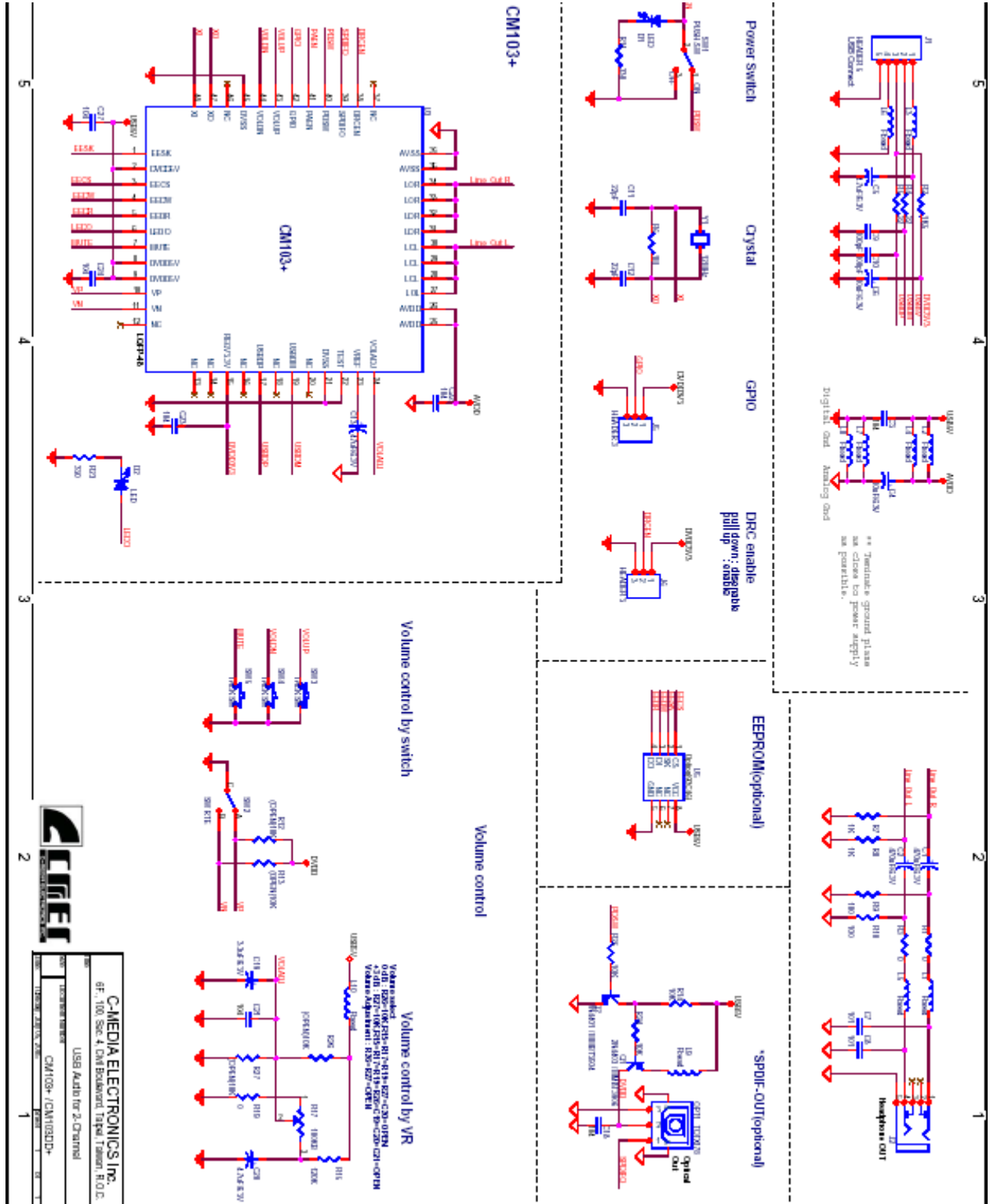



10. Reference

- ◆ Universal Serial Bus Specification, Version 2.0
- ◆ Universal Serial Bus Device Class Definition for Audio Devices, Version 1.0.
- ◆ Universal Serial Bus Device Class Definition for Human Interface Devices (HID), Version 1.11

— **End of Specifications** —

C-MEDIA ELECTRONICS INC.

6F., 100, Sec. 4, Civil Boulevard, Taipei, Taiwan 106 R.O.C.

TEL:886-2-8773-1100

FAX:886-2-8773-2211

E-mail : sales@cmedia.com.tw URL : <http://www.cmedia.com.tw>