

Dual Synchronous DC/DC Controllers With Current Sharing Circuitry

FEATURES

- Two sets of integrated MOSFET drivers
- Fixed operating frequency of 300, 600 or 1000kHz
- Dual-phase current-sharing controller to minimize ripple and improve transient response
- Wide input supply range: 4.5V to 16V
- Programmable output as low as 0.8v
- Internal error amplifier reference voltage of 0.7V +/- 1%
- Programmable over-current protection (OCP) with 50% fold-back
- Over-voltage protection (OVP)
- Soft-start
- Remote ON/OFF control
- High voltage pin up to 30V for bootstrap voltage
- Power-good output signal provided
- Current-sharing balance within +/-5% matching (SS9175CS/SS9176CS)
- Two independent PWM controllers (SS9175)
- Packaged in SO-20 (9175/CS) or SO-16 (9176CS)

DESCRIPTION

The SS9175/6 series are dual-phase synchronous DC/DC PWM controllers for power supplies requiring a single high-current output, or two independent outputs with high conversion efficiency. They integrate two sets of internal MOSFET drivers consisting of high-side and low side driving circuits. The internal temperature-independent reference voltage is trimmed to 0.7V +/- 1%, and is connected to the error amplifier's positive terminal for voltage feedback regulation. The over-current protection (OCP) level, with 50% fold-back, can be programmed by an external resistor. The over-voltage protection (OVP) point is fixed at 25% higher above 0.7V. The soft-start circuit ensures the duty cycle of the PWM output can be gradually and smoothly increased from zero to its desired value. The controllers can be remotely turned ON or OFF to enter into either active or standby mode, respectively. The SS9175/6 series provides three different options:

APPLICATIONS

- CPU and DSP Vcore Power Supply
- Graphic cards
- Telecomm and datacomm POL boards
- Power supplies requiring two independent outputs

The SS9175 is a 20-pin version that is designed for two independent outputs without current sharing capability.

The SS9175CS is a 20-pin version designed for current sharing applications.

The SS9176CS is a 16-pin version for current sharing applications.

TYPICAL APPLICATION CIRCUIT

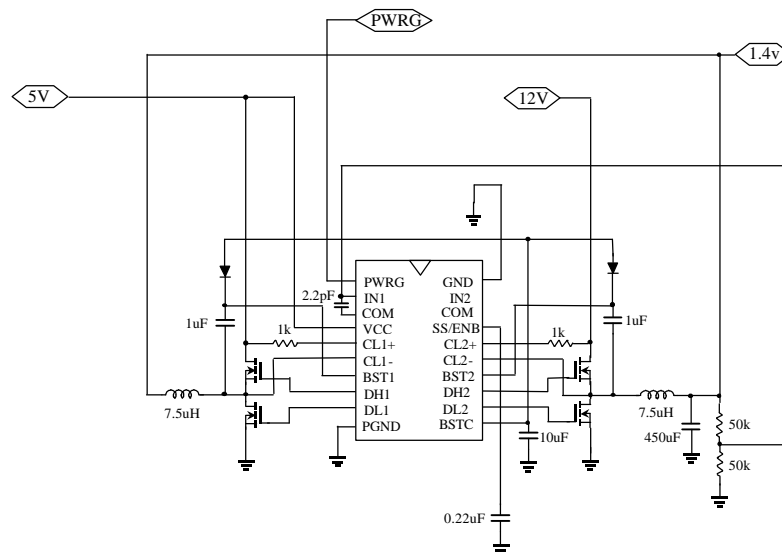

ORDERING INFORMATION

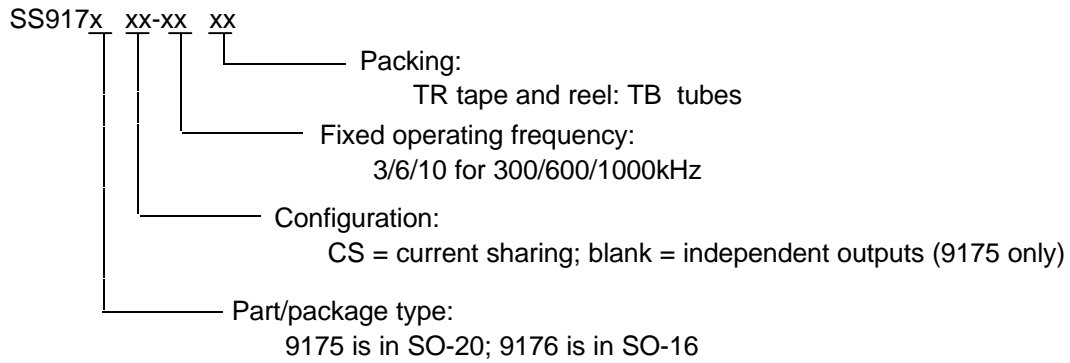

Examples: SS9176CS-10TR
 SS9176 with current-sharing outputs, 1000kHz in SO-16 on tape and reel

SS9175-6TR
 SS9175 with independent outputs, 600kHz in SO-20 on tape and reel

MARKING INFORMATION

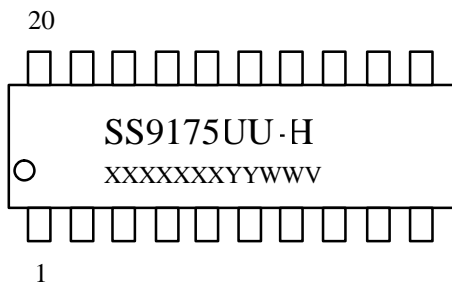

UU: = SS9175
 UU: CS = SS9175CS
 H: 3, 6 or 10
 XXXXXXXX: Wafer Lot
 YY: Year; WW: Week
 V: Assembly Location

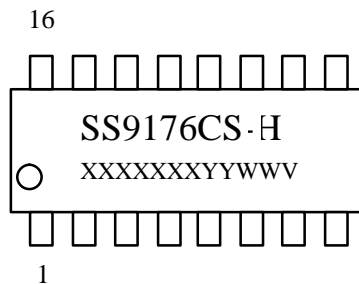

H: 3, 6 or 10
 XXXXXXXX: Wafer Lot
 YY: Year; WW: Week
 V: Assembly Location

ABSOLUTE MAXIMUM RATINGS

Symbol	Parameter	Test Condition	Value	Unit
<i>V_{CC}</i>	Supply voltage, VCC to GND	Low impedance source	20	V
<i>PGND</i>	PGND to GND		± 0.7	V
<i>VBST</i>	BST to PGND		30	V
<i>RT j-a</i>	Thermal resistance, Junction-air		90	°C/W
<i>T_J</i>	Operating junction temperature	-	-40 to +125	°C
<i>T_A</i>	Operating ambient temperature	-	-30 to +85	°C
<i>T_{stg}</i>	Storage temperature range	-	-65 to +150	°C
	ESD Capability, HBM model		2.0	kV
	ESD Capability, Machine model		200	V

RECOMMENDED OPERATING CONDITIONS

Symbol	Parameter	Min.	Max.	Unit
<i>VCC</i>	Supply voltage	4.5	16	V
<i>T_A</i>	Operating ambient temperature	0	70	°C

ELECTRICAL CHARACTERISTICS (V_{CC}=12V, T_a=25°C)
Oscillator Section

Symbol	Parameter	Test Condition	Min.	Typ.	Max.	Unit
<i>Fosc-3</i>	Oscillator frequency -3 version	T _a =25°C	270	300	330	KHz
<i>Fosc-6</i>	Oscillator frequency -6 version	T _a =25°C	550	600	650	KHz
<i>Fosc-10</i>	Oscillator frequency -10 version	T _a =25°C	920	1000	1080	KHz
<i>fdv</i>	Frequency change with VCC	VCC=4.5 to 16V	-	0.2		%
<i>fdt</i>	Frequency change with temp.	T _a =0 to 70°C	-	0.02	-	%/°C
<i>DC_{Max}</i>	Maximum duty cycle		85	95		%

Error Amplifier Section

Symbol	Parameter	Test Condition	Min.	Typ.	Max.	Unit
<i>V_{ref}</i>	Internal reference voltage	T _a =25°C	0.693	0.7	0.707	V
<i>A_{vol}</i>	Open-loop voltage gain	-	45	55	-	dB
<i>BW</i>	Unity gain bandwidth	-	0.7	1.2	-	MHz
<i>PSRR</i>	Power supply rejection ratio	-	50	-	-	dB
<i>I_{source}</i>	Output source current					mA
<i>I_{sink}</i>	Output sink current					mA
<i>V_{H COMP}</i>	Output voltage					V
<i>V_{L COMP}</i>	Output voltage					mV

Output Section

Symbol	Parameter	Test Condition	Min.	Typ.	Max.	Unit
<i>T_r</i>	Rising time	T _a =25°C, CL=10nF	-	20	50	nS
<i>T_f</i>	Falling time	T _a =25°C, CL=10nF	-	20	50	nS
<i>I_{DH, CH}</i>	High side source current		1			A
<i>I_{DH, DIS}</i>	High side sink current		1			A

Total Operating Current Section

Symbol	Parameter	Test Condition	Min.	Typ.	Max.	Unit
<i>I_{CC OP}</i>	Operating supply current	VCC=12V, OUTPUT=1000pF	-	5.0		mA
<i>I_{CC SBY}</i>	Standby current (disabled)			0.5		mA

BLOCK DIAGRAMS

SS9175

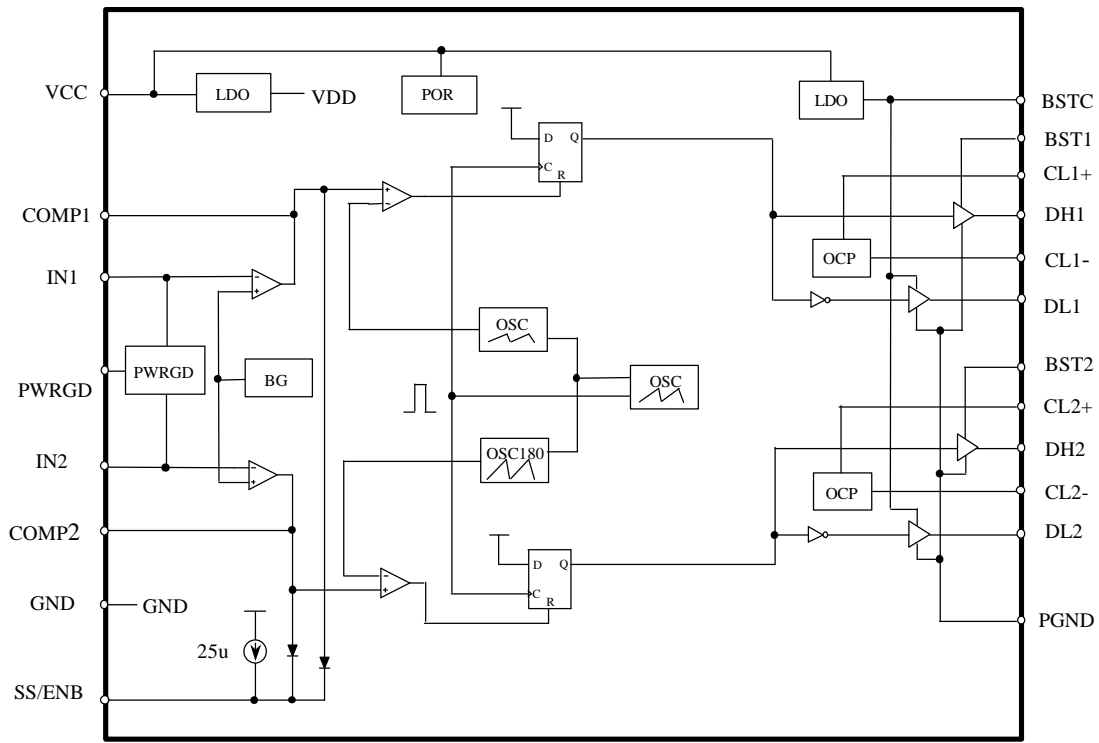

SS9175CS

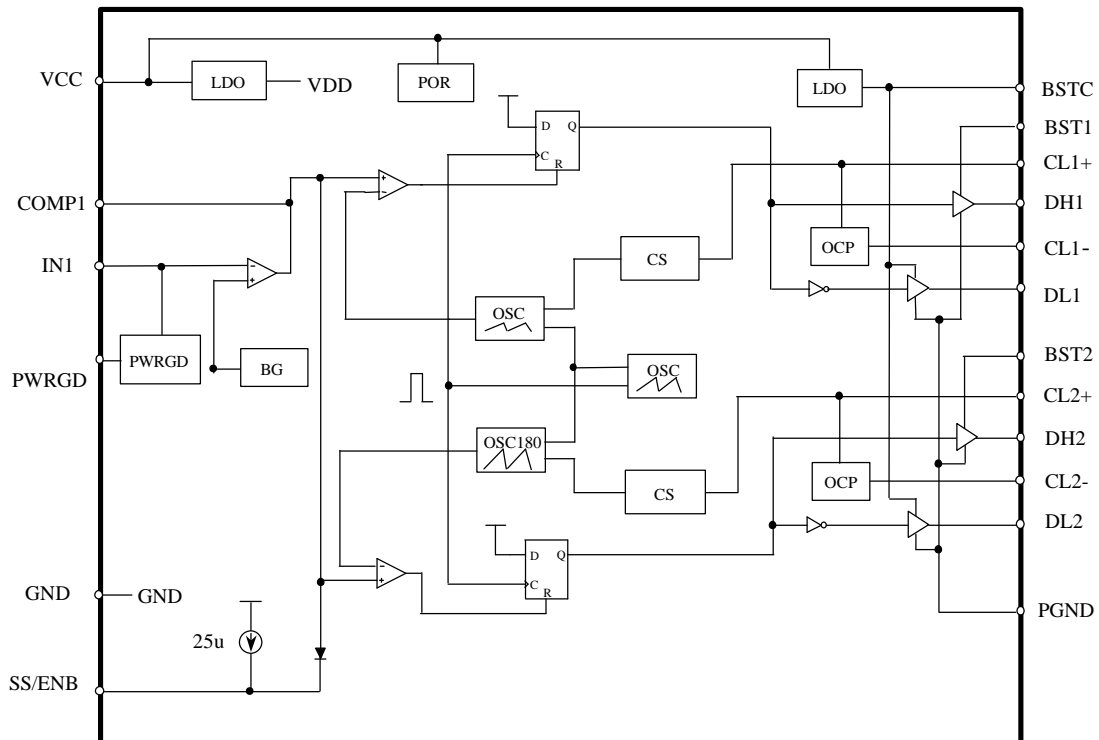

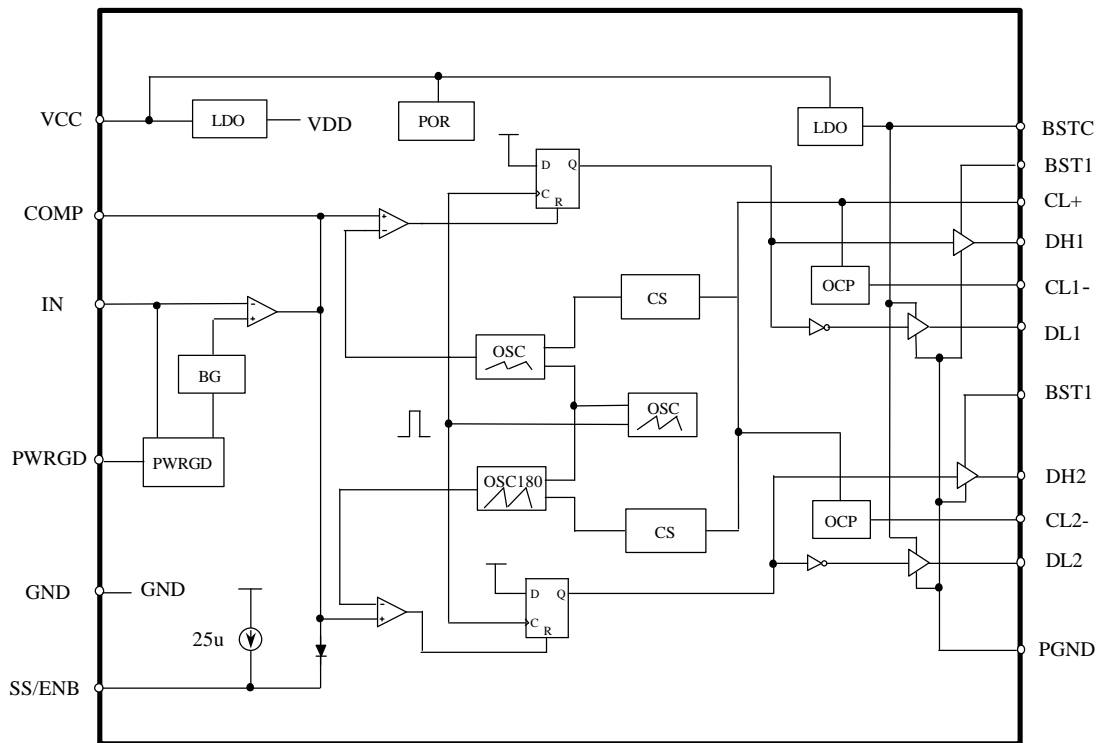
BLOCK DIAGRAMS (cont.)
SS9176CS

PIN DESCRIPTIONS

Pin No.	Symbol	Function	Description
1 (1)	PWRGD	Power-good	Output of the error amplifier and input to the PWM comparator. It is used for feedback loop compensation.
2 (2)	IN1	Feedback	Inverting input of the error amplifier. It is normally connected to the switching power supply output through a resistor divider.
3 (3)	COMP1	Compensation	Output of the error amplifier and input to the PWM comparator. It is used for feedback loop compensation.
4 (4)	VCC	Power Supply	Supply voltage input.
5	CL1+	Over-current	Over-current adjustment and high-side MOSFET supply voltage sense pin. Connect a resistor from this pin to high-side supply voltage.
6	CL1-	Over-current	Over-current sense pin.
7 (5)	BST1	Boost supply	Supply for high-side driver. Connect to bootstrap circuit.
8 (6)	DH1	High-side drive	High-side MOSFET gate driver pin.
9 (7)	DL1	Low-side drive	Low-side MOSFET gate driver pin.
10 (8)	PGND	Driver ground	Driver circuit GND supply. Connect to MOSFET's GND.
11 (9)	BSTC	Buffered supply	Voltage supply for internal low-side driver circuit and for high-side bootstrap circuit's diode input. Its output is 6V if chip supply voltage VCC > 6.5V. If VCC < 6.5V, then BSTC = VCC. Need a 10uF decoupling capacitor connected to PGND.
12 (10)	DL2	Low-side drive	Low-side MOSFET gate driver pin.
13 (11)	DH2	High-side drive	High-side MOSFET gate driver pin.
14 (12)	BST2	Boost supply	Supply for high-side driver. Connect to bootstrap circuit.
15 (13)	CL2-	Over-current	Over-current sense pin.
16 (14)	CL2+	Over-current	Over-current adjustment and high-side MOSFET supply voltage sense pin. Connect a resistor from this pin to high-side supply voltage.
17 (15)	SS/EN	Soft-start/Enable	A 25uA internal current source charges an external capacitor for soft start. Pull down this pin to disable the chip.
18	COMP2 [NC]	Compensation	Output of the error amplifier and input to the PWM comparator. It is used for feedback loop compensation.
19	IN2 [NC]	Feedback	Inverting input of the error amplifier. It is normally connected to the switching power supply output through a resistor divider.
20 (16)	GND	Control ground	Control circuit GND supply.

Note: Inside () is the pin assignment for SS9176CS. Inside [] is for SS9175CS.

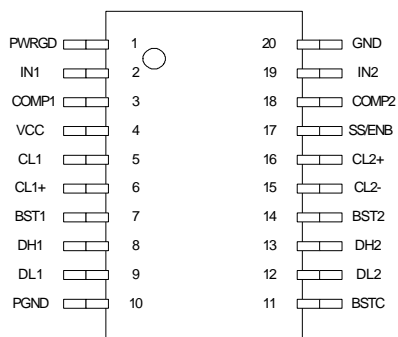
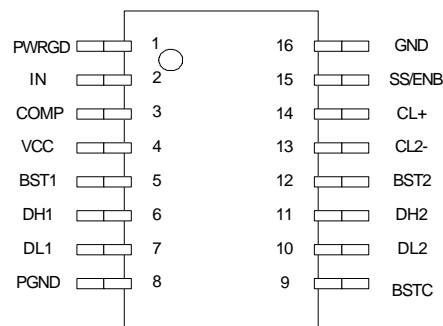
PIN CONFIGURATIONS
SS9175

SS9176

APPLICATION INFORMATION

OPERATION

The SS9175/6 series controllers integrate two sets of synchronous MOSFET driver circuits with current sharing capability. The following descriptions highlight the advantages of the SS917x designs.

Soft-start

A 25uA start-up current is provided by the SS/EN pin for the start-up sequence. During this start-up sequence, the SS917x is disabled when the SS/EN pin is less than 1.0V. From 1.0V to 3.0V, PWM output duty cycle is gradually and smoothly increased to its desired value. During this time, the current sharing circuit is disabled for smooth soft start. After 3.0V, the current sharing circuit is enabled and the whole circuit operates normally.

Oscillator operation

The SS9175/6 series have three versions with different oscillation frequencies. The oscillation frequency is fixed at 300 kHz, 600 kHz or 1 MHz. The voltage amplitude of the internal saw tooth oscillator is from 1.2V to 2.8V.

Error amplifier

The error amplifier's inverting input is connected to the IN pin, and the output is connected to the COMP pin. The COMP output is available for external compensation, allowing designers to control the feedback-loop frequency-response. Non-inverting input is not wired out to a pin, but it is internally biased to a fixed $0.7V \pm 1\%$ voltage.

Over-current protection

The over-current protection (OCP) is implemented by adding a resistor from the MOSFET supply voltage to the CL+ pin, which sinks a 100uA current source. An internal comparator senses the voltage difference between CL+ and CL- pin. If the CL- pin voltage is lower than the CL+ pin voltage, meaning there is a larger current flowing through the high-side MOSFET, the comparator will trigger the OCP protection. The OCP function also has a 50% fold-back circuit to limit the MOSFET current within the desired over-current value.

Output driver

The high-side driver uses an external bootstrap circuit to provide the required boost supply voltage. The external bootstrap circuit uses the BSTC output voltage for providing the diode voltage. For the low-side driver, the supply voltage is coming from the BSTC output voltage, which is roughly 6V if VCC is larger than 6.5V. The output stage is designed to ensure zero cross-conduction current.

Current Sharing

The dual-phase controller has current-sharing capability to match both channels to within 5%.

APPLICATION INFORMATION (cont.)
REFERENCE CIRCUITS

Current sharing application using SS9176CS

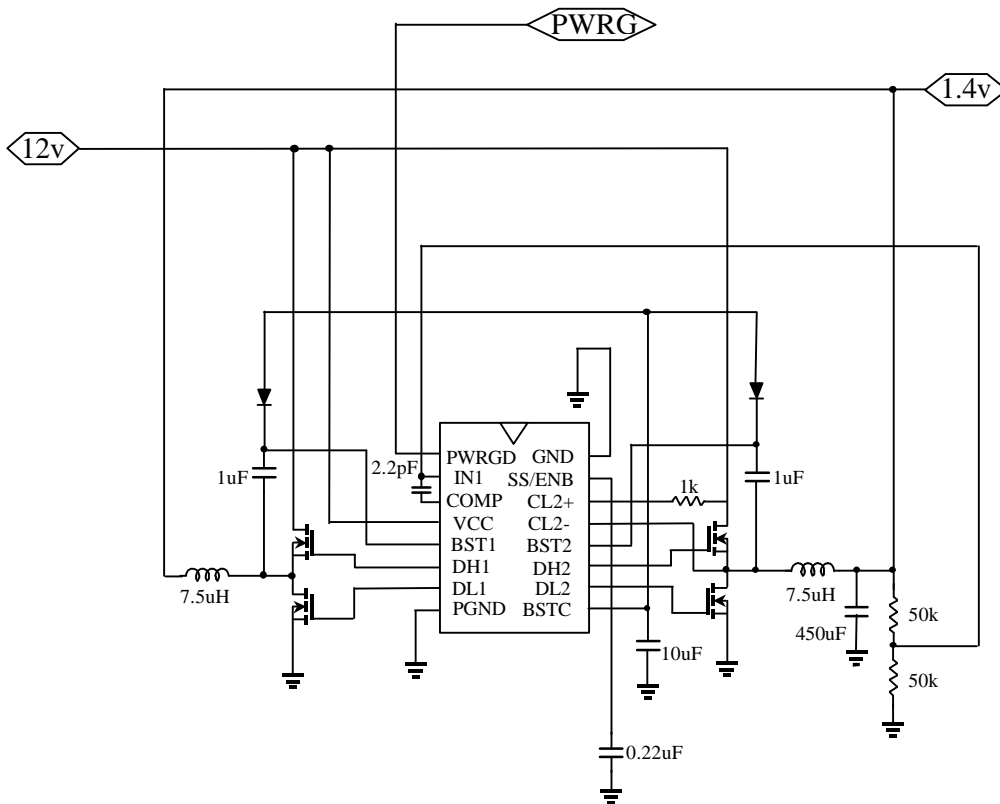

This current sharing circuit is implemented using the SS9176CS. The dual phase MOSFETs **must** be supplied from the same supply voltage (in this case, from 12V). They can also be supplied from a 5V supply voltage. As there is only a single output voltage (1.4V in this case), the divided voltage is fed back to the IN pin. The VCC supply voltage can be either 12V or 5V, depending on the

convenience of PCB layout, but VCC = 12V is recommended. If VCC > 6.5V, the BSTC output is fixed at 6V. This BSTC voltage is used as the supply voltage for the bootstrap circuit's diodes input. A 10uF capacitor is recommended for BSTC decoupling. A 1k resistor is connected from CL2+ to the MOSFET's high-side voltage. This 1k resistor is used to program the OCP level.

APPLICATION INFORMATION (cont.)

Current sharing application using SS9175CS

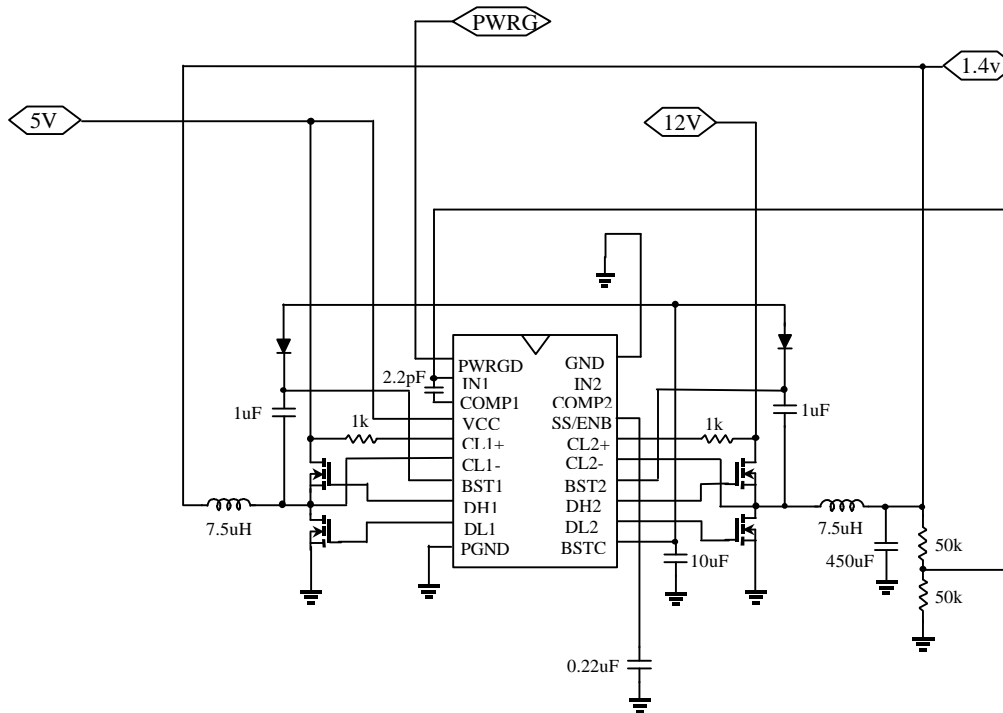

This current-sharing circuit is implemented using SS9175CS. The dual phase MOSFETs can be supplied from different supply voltages (in this case, from 12V for channel 2, and 5V for channel 1). They can be supplied from the same supply voltage, too. As there is only a single output voltage (1.4V in this case), the divided voltage is fed back to the IN1 pin. The VCC supply voltage can be either 12V or 5V, depending on the

convenience of PCB layout, but VCC = 12V is recommended. If VCC > 6.5V, the BSTC output is fixed at 6V. This BSTC voltage is used as the supply voltage for the bootstrap circuit's diodes input. A 10uF capacitor is recommended for BSTC decoupling. A 1k resistor is connected from CL2+ to the MOSFET's high-side voltage. This 1k resistor is used to program the OCP level.

■ APPLICATION INFORMATION (cont.)

Two independent voltage outputs using SS9175

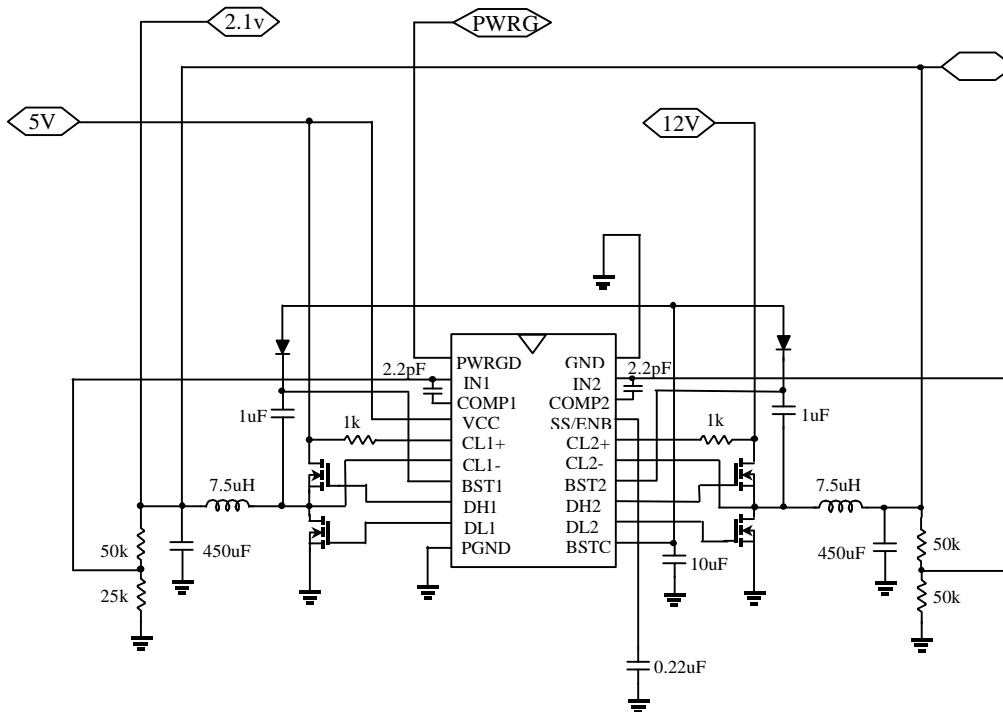

For independent outputs, this design is implemented using SS9175. The dual-phase MOSFETs can be supplied from different supply voltages (in this case, from 12V for channel 2, and 5V for channel 1). They can be supplied from the same supply voltage, too. As there are two independent output voltages (2.1V and 1.4V in this case), the divided voltages are fed back to their respective IN1 and IN2 pins. The VCC supply voltage can be either

12V or 5V, depending on the convenience of PCB layout, but VCC = 12V is recommended. If VCC > 6.5V, the BSTC output is fixed at 6V. This BSTC voltage is used as the supply voltage for the bootstrap circuit's diodes input. A 10uF capacitor is recommended for BSTC decoupling. A 1k resistor is connected from CL1+ and CL2+ to the MOSFET's high-side voltages. This 1k resistor is used to program the OCP level.

PHYSICAL DIMENSIONS

20 LEAD SOP (unit: inches)

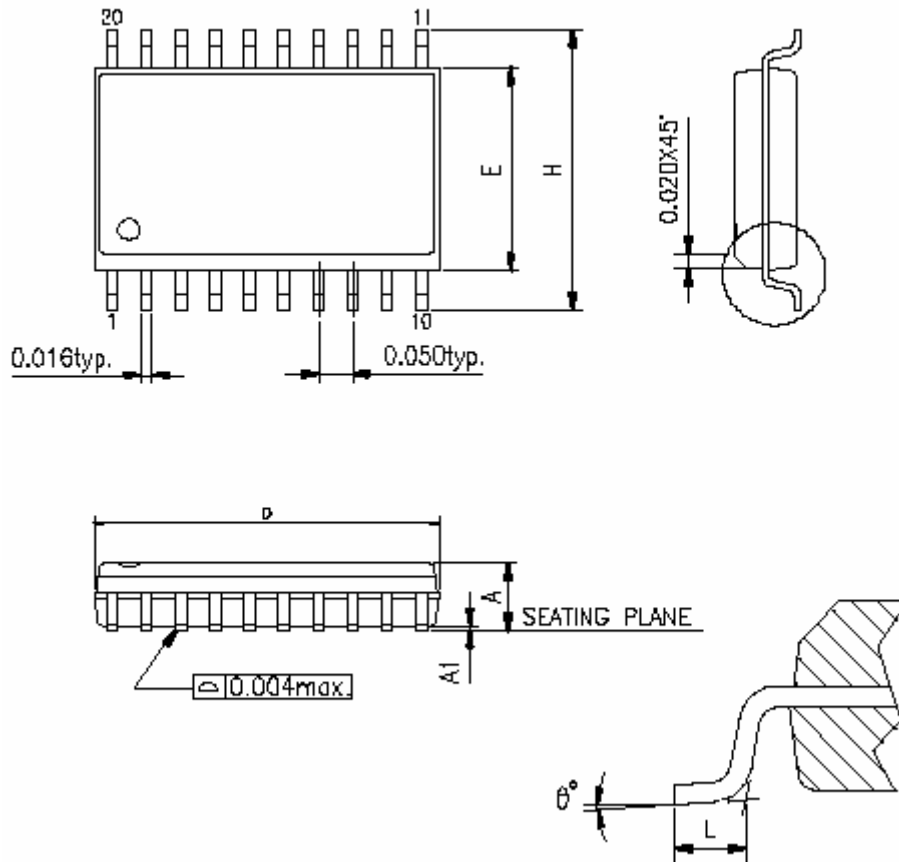

Dimensions:

SYMBOLS	MIN.	MAX.
A	0.093	0.104
A1	0.004	0.012
D	0.496	0.508
E	0.291	0.299
H	0.394	0.419
L	0.016	0.050
θ°	0	8

UNIT : INCH

PHYSICAL DIMENSIONS (cont.)

16 LEAD SOP (units: inches)

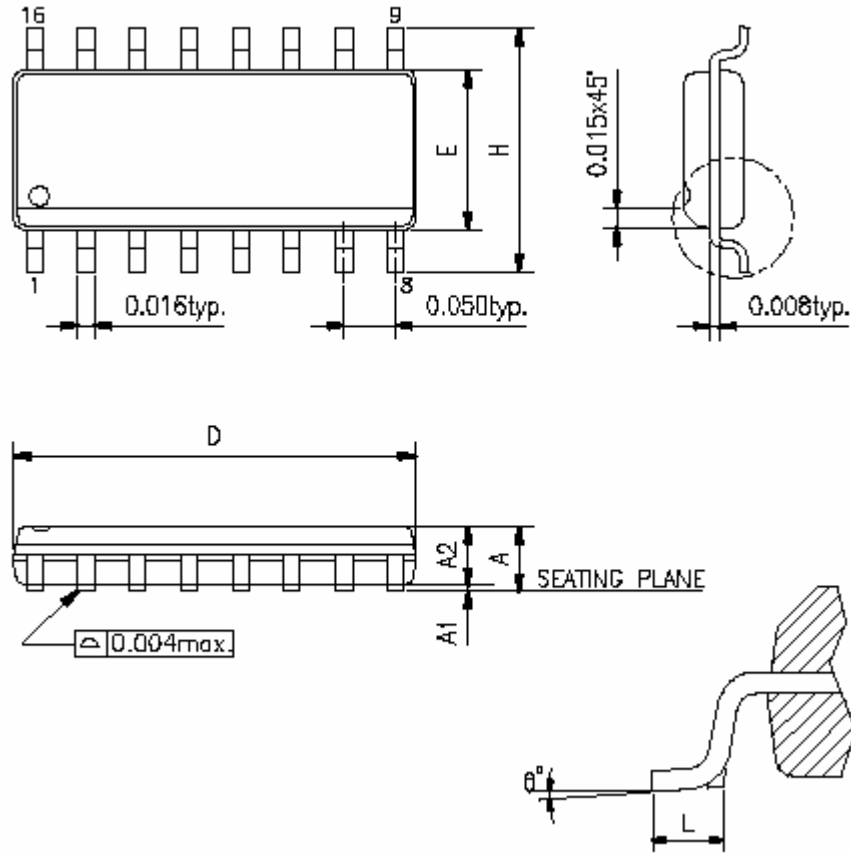

Dimensions:

SYMBOLS	MIN.	MAX.
A	0.053	0.069
A1	0.004	0.010
D	0.386	0.394
E	0.150	0.157
H	0.228	0.244
L	0.016	0.050
Ø	0	8

UNIT : INCH

Information furnished by Silicon Standard Corporation is believed to be accurate and reliable. However, Silicon Standard Corporation makes no guarantee or warranty, express or implied, as to the reliability, accuracy, timeliness or completeness of such information and assumes no responsibility for its use, or for infringement of any patent or other intellectual property rights of third parties that may result from its use. Silicon Standard reserves the right to make changes as it deems necessary to any products described herein for any reason, including without limitation enhancement in reliability, functionality or design. No license is granted, whether expressly or by implication, in relation to the use of any products described herein or to the use of any information provided herein, under any patent or other intellectual property rights of Silicon Standard Corporation or any third parties.