

UNCONTROLLED DOCUMENT

PART NUMBER
OCP-PCP116-TR

REV.
D

REV.	E.C.N. NUMBER AND REVISION COMMENTS	DATE
A	E.C.N. #10BRDR. & #10776.	8.16.01
B	E.C.N. #10815.	12.3.01
C	E.C.N. #1114B.	5.15.07
D	E.C.N. #11462.	12.14.07

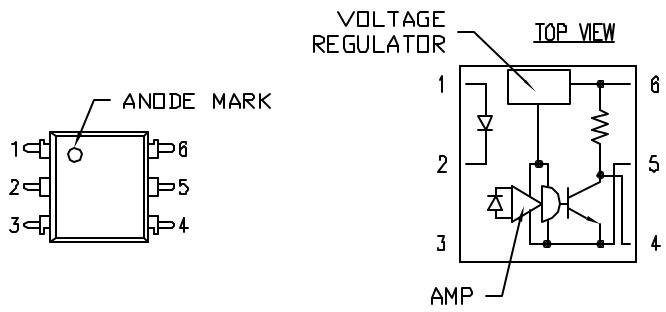

- NOTES:
1. ANODE
 2. CATHODE
 3. NO CONNECT
 4. COLLECTOR
 5. EMITTER
 6. VOLTAGE REGULATOR, V_{CC}
 7. RESISTOR IS 15K OHMS.

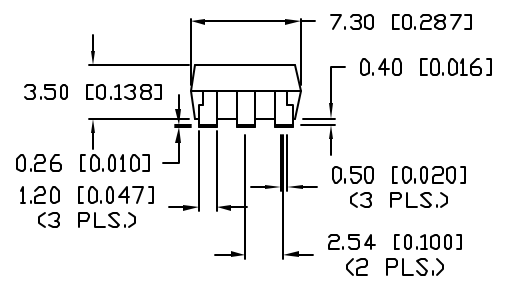
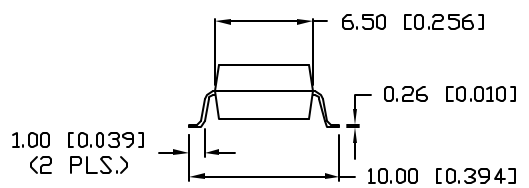

RECOMMENDED SOLDER PAD LAYOUT

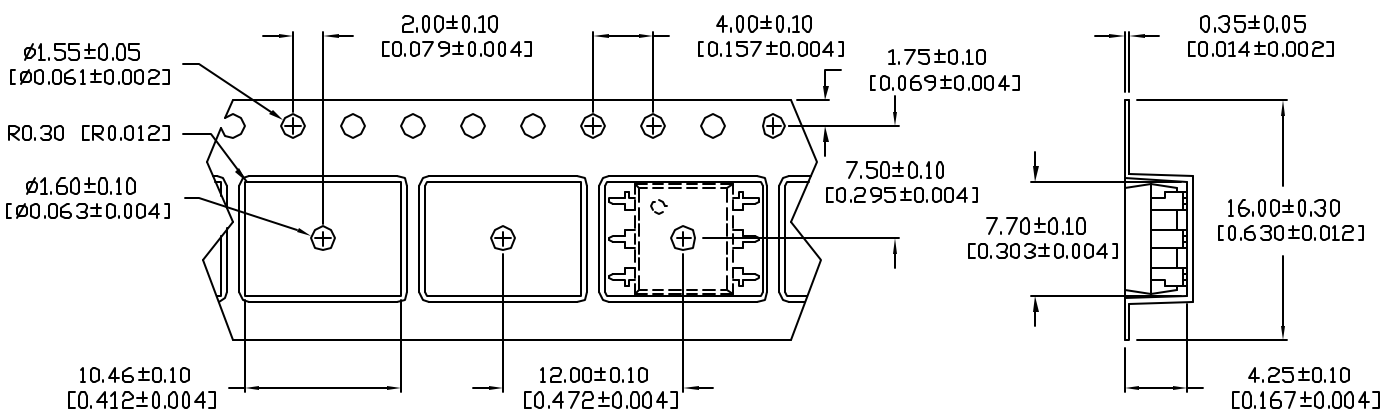
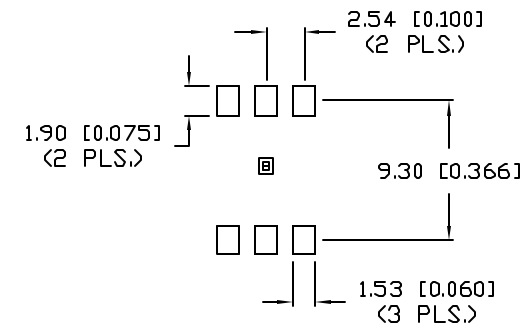

TAPE FEED DIRECTION →

*UNLESS OTHERWISE SPECIFIED TOLERANCES PER DECIMAL PRECISION ARE: X=±1 (±0.039), XX=±0.5 (±0.020), XXX=±0.25 (±0.010), XXXX=±0.127 (±0.005). LEAD SIZE=±0.05 (±0.002), LEAD LENGTH=±0.75 (±0.030), MIN.=+DECIMAL PRECISION -0.00, MAX.=+0.00 -DECIMAL PRECISION

UNCONTROLLED DOCUMENT

REV. D	PART NUMBER OCP-PCP116-TR
SIX PIN SINGLE CHANNEL SURFACE MOUNT PHOTO IC PHOTOCOUPLER.	

CONFIDENTIAL INFORMATION
THE INFORMATION CONTAINED IN THIS DOCUMENT IS THE PROPERTY OF LUMEX INC. EXCEPT AS SPECIFICALLY AUTHORIZED IN WRITING BY LUMEX INC., THE HOLDER OF THIS DOCUMENT SHALL KEEP ALL INFORMATION CONTAINED HEREIN CONFIDENTIAL AND SHALL PROTECT SAME IN WHOLE OR IN PART FROM DISCLOSURE AND DISSEMINATION TO ALL THIRD PARTIES.

RELIABILITY NOTE
OUR MANY YEARS OF EXPERIENCE DATA ACCUMULATION INDICATE THAT SOLDER HEAT IS A MAJOR CAUSE OF EARLY AND FUTURE FAILURE. PLEASE PAY ATTENTION TO YOUR SOLDERING PROCESS.

290 E. HELEN ROAD
PALATINE, IL 60067-6976
PHONE: +1.847.359.2790
US WEB: www.lumex.com
TW WEB: www.lumex.com.tw

DRAWN BY: JC
CHECKED BY:
APPROVED BY:
DATE: 9.29.99
PAGE: 1 OF 1
SCALE: N/A

DATE: 9.29.99
PAGE: 1 OF 1
SCALE: N/A

PART NUMBER		REV.
OCP-PCP116-TR		D
REV.	E.C.N. NUMBER AND REVISION COMMENTS	DATE
	SEE PAGE 1.	

ELECTRO-OPTICAL CHARACTERISTICS (T _a =25°C)							
	PARAMETER	SYMBOL	CONDITIONS	MIN	TYP	MAX	UNITS
I	FORWARD VOLTAGE	V _f	I _F =20mA	-	1.2	1.4	V
	PEAK FORWARD VOLTAGE	V _{FM}	I _{FM} =0.5A	-	-	3.5	V
	REVERSE CURRENT	I _R	V _R =4V	-	-	10	μA
	TERMINAL CAPACITANCE	C _t	V=0, f=1kHz	-	30	-	pF
O	OPERATING SUPPLY VOLTAGE	V _{CC}		4.5	-	17	V
	LOW LEVEL OUTPUT VOLTAGE	V _{OL}	I _{OL} =16mA, V _{CC} =5V, I _F =0	-	0.15	0.4	V
	HIGH LEVEL OUTPUT VOLTAGE	V _{OH}	V _{CC} =5V, I _F =1mA	3.5	-	-	V
	LOW LEVEL SUPPLY CURRENT	I _{CCL}	V _{CC} =5V, I _F =0	-	1.7	3.8	mA
	HIGH LEVEL SUPPLY CURRENT	I _{CCH}	V _{CC} =5V, I _F =1mA	-	0.7	2.2	mA
T	'HIGH->LOW' THRESHOLD INPUT CURRENT	I _{FHL}	V _{CC} =5V, R _L =280 ohms	0.1	0.4	-	mA
	'LOW->HIGH' THRESHOLD INPUT CURRENT	I _{FLH}	V _{CC} =5V, R _L =280 ohms	-	0.5	1.0	mA
	HYSTERESIS	I _{FHL} /I _{FLH}	V _{CC} =5V, R _L =280 ohms	-	0.7	-	-
	ISOLATION RESISTANCE	R _{ISO}	DC5000V	5x10 ¹⁰	10 ¹¹	-	ohm
R	'HIGH->LOW' PROPAGATION DELAY TIME	t _{PHL}	V _{CC} =5V, I _F =1mA, R _L =280 ohm	-	5	15	μS
	'LOW->HIGH' PROPAGATION DELAY TIME	t _{PLH}	V _{CC} =5V, I _F =1mA, R _L =280 ohm	-	3	9	μS
	FALL TIME	t _f	V _{CC} =5V, I _F =1mA, R _L =280 ohm	-	0.05	0.5	μS
	RISE TIME	t _r	V _{CC} =5V, I _F =1mA, R _L =280 ohm	-	0.1	0.5	μS

I=INPUT, O=OUTPUT, T=TRANSFER CHARACTERISTICS, R=RESPONSE TIME.

ABSOLUTE MAXIMUM RATINGS (T _a =25°C)				
	PARAMETER	SYMBOL	MAX	UNITS
I	FORWARD CURRENT	I _F	50	mA
	PEAK FORWARD CURRENT	I _{FM}	1	A
	REVERSE VOLTAGE	V _R	6	V
	POWER DISSIPATION	P _D	70	mW
O	SUPPLY VOLTAGE	V _{CC}	-0.5 TO 17	V
	OUTPUT CURRENT	I _O	50	mA
	POWER DISSIPATION	P _O	150	mW
	TOTAL POWER DISSIPATION	P _{TOT}	170	mW
	ISOLATION VOLTAGE 1 MIN.	V _{ISO}	5000	V _{RMS}
	OPERATING TEMP.	T _{opr}	- 25 TO + 85	°C
	STORAGE TEMP.	T _{stg}	- 40 TO + 125	°C
	SOLDERING TEMP.	T _{sol}	+260	°C
	2.0mm FROM BODY			10 SEC. MAX

I=INPUT, O=OUTPUT.

*UNLESS OTHERWISE SPECIFIED TOLERANCES PER DECIMAL PRECISION ARE: X=±1 (±0.039), XX=±0.5 (±0.020), XXX=±0.25 (±0.010), XXXX=±0.127 (±0.005). LEAD SIZE=±0.05 (±0.002), LEAD LENGTH=±0.75 (±0.030). MIN.= +DECIMAL PRECISION -0.00, MAX.= +0.00 -DECIMAL PRECISION

REV.	PART NUMBER		290 E. HELEN ROAD PALATINE, IL 60067-6976 PHONE: +1.847.359.2790 US WEB: www.lumex.com TW WEB: www.lumex.com.tw
D	OCP-PCP116-TR		
SIX PIN SINGLE CHANNEL SURFACE MOUNT PHOTO IC PHOTOCOUPLER.		CONFIDENTIAL INFORMATION THE INFORMATION CONTAINED IN THIS DOCUMENT IS THE PROPERTY OF LUMEX INC. EXCEPT AS SPECIFICALLY AUTHORIZED IN WRITING BY LUMEX INC., THE HOLDER OF THIS DOCUMENT SHALL KEEP ALL INFORMATION CONTAINED HEREIN CONFIDENTIAL AND SHALL PROTECT SAME IN WHOLE OR IN PART FROM DISCLOSURE AND DISSEMINATION TO ALL THIRD PARTIES.	RELIABILITY NOTE OUR MANY YEARS OF EXPERIENCE DATA ACCUMULATION INDICATE THAT SOLDER HEAT IS A MAJOR CAUSE OF EARLY AND FUTURE FAILURE. PLEASE PAY ATTENTION TO YOUR SOLDERING PROCESS.
		DRAWN BY: JG	CHECKED BY: APPROVED BY: DATE: 9.29.99 PAGE: 2 OF 2 SCALE: N/A