

## **SPLC783A**

---

### **16COM/80SEG Controller/Driver**

MAR. 10, 2005

Version 1.4

## Table of Contents

	<u>PAGE</u>
<b>1. GENERAL DESCRIPTION</b> .....	4
<b>2. BLOCK DIAGRAM</b> .....	4
<b>3. FEATURES</b> .....	4
<b>4. SIGNAL DESCRIPTIONS</b> .....	5
4.1. PIN MAP .....	6
<b>5. FUNCTIONAL DESCRIPTIONS</b> .....	7
5.1. OSCILLATOR .....	7
5.2. CONTROL AND DISPLAY INSTRUCTIONS .....	7
5.3. INSTRUCTION TABLE .....	9
5.4. 8-BIT OPERATION AND 8-DIGIT 1-LINE DISPLAY (USING INTERNAL RESET) .....	10
5.5. 4-BIT OPERATION AND 8-DIGIT 1-LINE DISPLAY (USING INTERNAL RESET) .....	11
5.6. 8-BIT OPERATION AND 8-DIGIT 2-LINE DISPLAY (USING INTERNAL RESET) .....	11
5.7. RESET FUNCTION .....	12
5.8. DISPLAY DATA RAM (DD RAM) .....	14
5.9. TIMING GENERATION CIRCUIT .....	14
5.10. LCD DRIVER CIRCUIT .....	14
5.11. CHARACTER GENERATOR ROM (CG ROM) .....	14
5.12. CHARACTER GENERATOR RAM (CG RAM) .....	14
5.13. CURSOR/BLINK CONTROL CIRCUIT .....	18
5.14. INTERFACING TO MPU .....	19
5.15. SUPPLY VOLTAGE FOR LCD DRIVE .....	20
5.16. REGISTER --- IR (INSTRUCTION REGISTER) AND DR (DATA REGISTER) .....	23
5.17. BUSY FLAG (BF) .....	23
5.18. ADDRESS COUNTER (AC) .....	23
5.19. I/O PORT CONFIGURATION .....	23
<b>6. ELECTRICAL SPECIFICATIONS</b> .....	24
6.1. ABSOLUTE MAXIMUM RATINGS .....	24
6.2. DC CHARACTERISTICS (VDD = 2.7V TO 4.5V, TA = 25°C) .....	24
6.3. AC CHARACTERISTICS (VDD = 2.7V TO 4.5V, TA = 25°C) .....	25
6.4. DC CHARACTERISTICS (VDD = 4.5V TO 5.5V, TA = 25°C) .....	26
6.5. AC CHARACTERISTICS (VDD = 4.5V TO 5.5V, TA = 25°C) .....	26
<b>7. APPLICATION CIRCUITS</b> .....	29
7.1. R-OSCILLATOR .....	29
7.2. INTERFACE TO MPU .....	29
7.3. SPLC783A APPLICATION CIRCUIT .....	30
7.4. APPLICATIONS FOR LCD .....	30
<b>8. CHARACTER GENERATOR ROM</b> .....	33
8.1. SPLC783A - 001 .....	33
8.2. SPLC783A - 003 .....	34

---

<b>9. PACKAGE/PAD LOCATIONS</b> .....	<b>35</b>
9.1. PAD ASSIGNMENT AND LOCATIONS .....	35
9.2. PACKAGE INFORMATION .....	35
9.3. ORDERING INFORMATION .....	35
9.4. STORAGE CONDITION AND PERIOD FOR PACKAGE .....	36
9.5. RECOMMENDED SMT TEMPERATURE PROFILE .....	36
<b>10. DISCLAIMER</b> .....	<b>37</b>
<b>11. REVISION HISTORY</b> .....	<b>38</b>

Sunplus Confidential  
For PARTMINER Use Only

## 16COM/80SEG CONTROLLER/DRIVER

### 1. GENERAL DESCRIPTION

The SPLC783A, a dot-matrix LCD controller and driver from SUNPLUS, is a unique design for displaying alpha-numeric, Japanese-Kana characters and symbols. The SPLC783A provides two types of interfaces to MPU: 4-bit and 8-bit interfaces. The transferring speed of 8-bit is twice faster than 4-bit. A single SPLC783A is able to display up to two 16-character lines. By cascading with SPLC100 or SPLC063, the display capability can be extended. The CMOS technology ensures the power saves in the most efficient way and the performance keeps in the highest rank.

### 2. BLOCK DIAGRAM

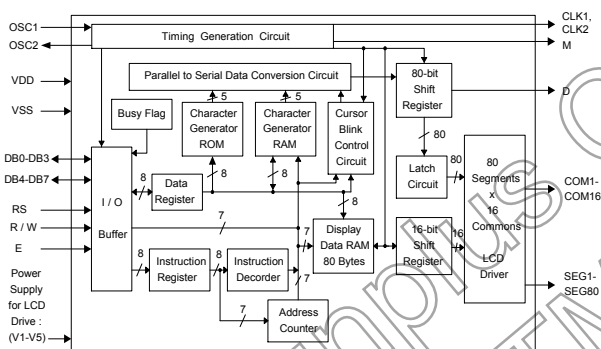

### 3. FEATURES

- Character generator ROM: 10880 bits
  - Character font 5 x 8 dots: 192 characters
  - Character font 5 x 10 dots: 64 characters
- Character generator RAM: 512 bits
  - Character font 5 x 8 dots: 8 characters
  - Character font 5 x 10 dots: 4 characters
- 4-bit or 8-bit MPU interfaces
- Direct driver for LCD: 16 COMs x 80 SEGs
- Duty factor (selected by program):
  - 1/8 duty: 1 line of 5 x 8 dots
  - 1/11 duty: 1 line of 5 x 10 dots
  - 1/16 duty: 2 lines of 5 x 8 dots / line
- Built-in power on automatic reset circuit
- Built-in oscillator circuit (with external resistor)
- Support external clock operation
- Low Power Consumption
- Package form: bare chip available

**4. SIGNAL DESCRIPTIONS**

Mnemonic	PIN No.	Type	Description
VDD	49	I	Power input
VSS	34	I	Ground
OSC1 OSC2	36 35	-	Both OSC1 and OSC2 are connected to resistor for internal oscillator circuit. For external clock operation, the clock is input to OSC1.
V1 - V5	37 - 41	I	Supply voltage for LCD driving.
E	48	I	A start signal for reading or writing data.
R/W	47	I	A signal for selecting read or write actions. 1: Read, 0: Write.
RS	46	I	A signal for selecting registers. 1: Data Register (for read and write) 0: Instruction Register (for write), Busy flag - Address Counter (for read)
DB0 - DB3	50 - 53	I/O	Low 4-bit data
DB4 - DB7	54 - 57	I/O	High 4-bit data
CLK1	42	O	Clock to latch serial data D.
CLK2	43	O	Clock to shift serial data D.
M	44	O	Switch signal to convert LCD waveform to AC.
D	45	O	Sends character pattern data corresponding to each common signal serially. 1: Selection, 0: Non-selection.
SEG1 - SEG33 SEG34 - SEG80	33 - 1 121 - 75	O	Segment signals for LCD.
COM1 - COM16	59 - 74	O	Common signals for LCD.
TEST	58	I	TEST pin. This pin must be fixed to VDD or open.

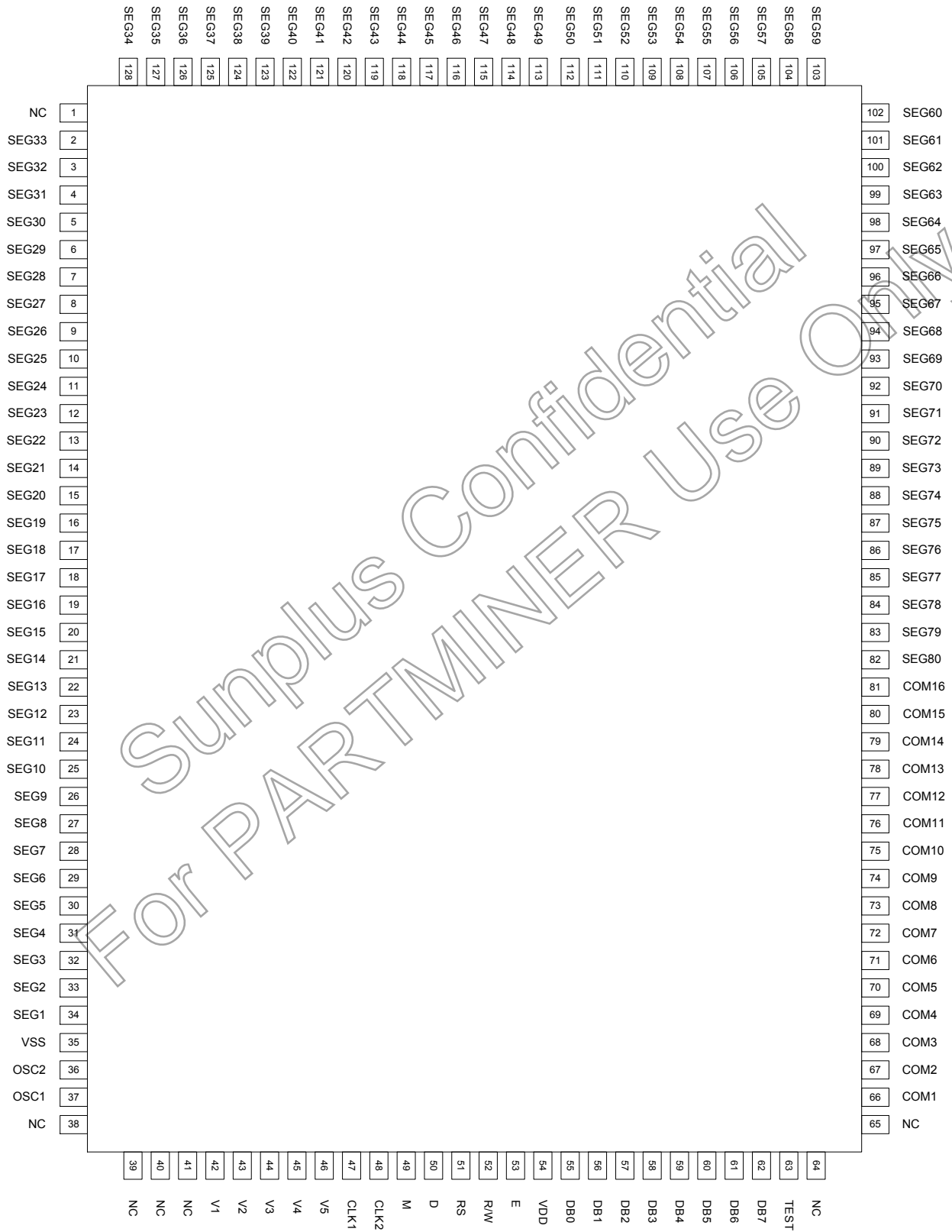
**4.1. PIN Map**

## 5. FUNCTIONAL DESCRIPTIONS

### 5.1. Oscillator

SPLC783A oscillator supports not only the internal oscillator operation, but also the external clock operation.

### 5.2. Control and Display Instructions

Control and display instructions are described in details as follows:

#### 5.2.1. Clear display

	RS	R/W	DB7	DB6	DB5	DB4	DB3	DB2	DB1	DB0
Code	0	0	0	0	0	0	0	0	0	1

It clears the entire display and sets Display Data RAM Address 0 in Address Counter.

#### 5.2.2. Return home

	RS	R/W	DB7	DB6	DB5	DB4	DB3	DB2	DB1	DB0
Code	0	0	0	0	0	0	0	0	1	X

X: Do not care (0 or 1)

It sets Display Data RAM Address 0 in Address Counter and the display returns to its original position. The cursor or blink goes to the most-left side of the display (to the 1st line if 2 lines are displayed). The contents of the Display Data RAM do not change.

#### 5.2.3. Entry mode set

During writing and reading data, it defines cursor moving direction and shifts the display.

	RS	R/W	DB7	DB6	DB5	DB4	DB3	DB2	DB1	DB0
Code	0	0	0	0	0	0	0	1	I/D	S

I / D = 1: Increment, I / D = 0: Decrement.

S = 1: The display shift, S = 0: The display does not shift.

S = 1	I / D = 1	It shifts the display to the left
S = 1	I / D = 0	It shifts the display to the right

#### 5.2.4. Display ON/OFF control

	RS	R/W	DB7	DB6	DB5	DB4	DB3	DB2	DB1	DB0
Code	0	0	0	0	0	0	1	D	C	B

D = 1: Display on, D = 0: Display off

C = 1: Cursor on, C = 0: Cursor off

B = 1: Blinks on, B = 0: Blinks off

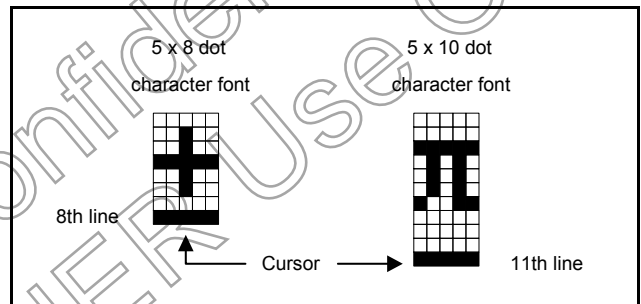

#### 5.2.5. Cursor or display shift

Without changing DD RAM data, it moves cursor and shifts display.

	RS	R/W	DB7	DB6	DB5	DB4	DB3	DB2	DB1	DB0
Code	0	0	0	0	0	1	S/C	R/L	X	X

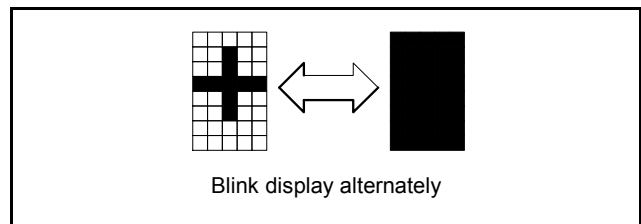

S/C	R/L	Description	Address Counter
0	0	Shift cursor to the left	AC = AC - 1
0	1	Shift cursor to the right	AC = AC + 1
1	0	Shift display to the left. Cursor follows the display shift	AC = AC
1	1	Shift display to the right. Cursor follows the display shift	AC = AC

**5.2.6. Function set**

	RS	R/W	DB7	DB6	DB5	DB4	DB3	DB2	DB1	DB0
Code	0	0	0	0	1	DL	N	F	X	X

X: Do not care (0 or 1)

DL: It sets interface data length.

DL = 1: Data transferred with 8-bit length (DB7 - 0).

DL = 0: Data transferred with 4-bit length (DB7 - 4).

It requires two times to accomplish data transferring.

N: It sets the number of the display line.

N = 0: One-line display.

N = 1: Two-line display.

F: It sets the character font.

F = 0: 5 x 8 dots character font.

F = 1: 5 x 10 dots character font.

N	F	No. of Display Lines	Character Font	Duty Factor
0	0	1	5 x 8 dots	1 / 8
0	1	1	5 x 10 dots	1 / 11
1	X	2	5 x 8 dots	1 / 16

It cannot display two lines with 5 x 10 dots character font.

**5.2.7. Set character generator RAM address**

	RS	R/W	DB7	DB6	DB5	DB4	DB3	DB2	DB1	DB0
Code	0	0	0	1	a	a	a	a	a	a

It sets Character Generator RAM Address (aaaaaa)<sub>2</sub> to the Address Counter.

Character Generator RAM data can be read or written after this setting.

**5.2.8. Set display data RAM address**

	RS	R/W	DB7	DB6	DB5	DB4	DB3	DB2	DB1	DB0
Code	0	0	1	a	a	a	a	a	a	a

It sets Display Data RAM Address (aaaaaa)<sub>2</sub> to the Address Counter.

Display data RAM can be read or written after this setting.

In one-line display (N = 0),

$$(aaaaaaa)_2: (00)_{16} - (4F)_{16}.$$

In two-line display (N = 1),

$$(aaaaaaa)_2: (00)_{16} - (27)_{16} \text{ for the first line,}$$

$$(aaaaaaa)_2: (40)_{16} - (67)_{16} \text{ for the second line.}$$

**5.2.9. Read busy flag and address**

	RS	R/W	DB7	DB6	DB5	DB4	DB3	DB2	DB1	DB0
Code	0	1	BF	a	a	a	a	a	a	a

When BF = 1, it indicates the system is busy now and it will not accept any instruction until not busy (BF = 0). At the same time, the content of Address Counter (aaaaaa)<sub>2</sub> is read.

**5.2.10. Write data to character generator RAM or display data RAM**

	RS	R/W	DB7	DB6	DB5	DB4	DB3	DB2	DB1	DB0
Code	1	0	d	d	d	d	d	d	d	d

It writes data (ddddddd)<sub>2</sub> to character generator RAM or display data RAM.

**5.2.11. Read data from character generator RAM or display data RAM**

	RS	R/W	DB7	DB6	DB5	DB4	DB3	DB2	DB1	DB0
Code	1	1	d	d	d	d	d	d	d	d

It reads data (ddddddd)<sub>2</sub> from character generator RAM or display data RAM.

To read data correctly, do the following:

- 1). The address of the Character Generator RAM or Display Data RAM or shift the cursor instruction.
- 2). The "Read" instruction.



**5.3. Instruction Table**

Instruction	Instruction Code										Description	Execution time			
	RS	R/W	DB7	DB6	DB5	DB4	DB3	DB2	DB1	DB0		Fosc= 190KHz	Fosc= 270KHz	Fosc= 350KHz	
Clear Display	0	0	0	0	0	0	0	0	0	0	1	Write "20H" to DDRAM and set DDRAM address to "00H" from AC	2.16ms	1.52ms	1.18ms
Return Home	0	0	0	0	0	0	0	0	0	1	-	Set DDRAM address to "00H" from AC and return cursor to its original position if shifted. The contents of DDRAM are not changed.	2.16ms	1.52ms	1.18ms
Entry Mode Set	0	0	0	0	0	0	0	0	1	I/D	S	Assign cursor moving direction and enable the shift of entire display	53μs	38μs	29μs
Display ON/OFF Control	0	0	0	0	0	0	0	1	D	C	B	Set display (D), cursor(C), and blinking of cursor(B) on/off control bit.	53μs	38μs	29μs
Cursor or Display Shift	0	0	0	0	0	1	S/C	R/L	-	-	-	Set cursor moving and display shift control bit, and the direction, without changing of DDRAM data.	53μs	38μs	29μs
Function Set	0	0	0	0	1	DL	N	F	-	-	-	Set interface data length (DL: 8-bit/4-bit), numbers of display line (N: 2-line/1-line) and, display font type (F:5x10 dots/5x8 dots)	53μs	38μs	29μs
Set CGRAM Address	0	0	0	1	AC5	AC4	AC3	AC2	AC1	AC0		Set CGRAM address in address counter.	53μs	38μs	29μs
Set DDRAM Address	0	0	1	AC6	AC5	AC4	AC3	AC2	AC1	AC0		Set DDRAM address in address counter	53μs	38μs	29μs
Read Busy Flag and Address Counter	0	1	BF	AC6	AC5	AC4	AC3	AC2	AC1	AC0		Whether during internal operation or not can be known by reading BF. The contents of address counter can also be read.			
Write Data to RAM	1	0	D7	D6	D5	D4	D3	D2	D1	D0		Write data into internal RAM (DDRAM/CGRAM).	53μs	38μs	29μs
Read Data from RAM	1	1	D7	D6	D5	D4	D3	D2	D1	D0		Read data from internal RAM (DDRAM/CGRAM).	53μs	38μs	29μs

Note: "-": don't care

**5.4. 8-Bit Operation and 8-Digit 1-Line Display (Using Internal Reset)**

No.	Instruction	Display	Operation
1	Power on. (SPLC783A starts initializing)	<input type="text"/>	Power on reset. No display.
2	Function set RS R/W DB7 DB6 DB5 DB4 DB3 DB2 DB1 DB0 <input type="text"/>	<input type="text"/>	Set to 8-bit operation and select 1-line display line and character font.
3	Display on / off control <input type="text"/>	<input type="text"/>	Display on. Cursor appear.
4	Entry mode set <input type="text"/>	<input type="text"/>	Increase address by one. It will shift the cursor to the right when writing to the DD RAM/CG RAM. Now the display has no shift.
5	Write data to CG RAM / DD RAM <input type="text"/>	<input type="text"/>	Write " W ". The cursor is incremented by one and shifted to the right.
6	Write data to CG RAM / DD RAM <input type="text"/>	<input type="text"/>	Write " E ". The cursor is incremented by one and shifted to the right.
7	:	:	
8	Write data to CG RAM / DD RAM <input type="text"/>	<input type="text"/>	Write " E ". The cursor is incremented by one and shifted to the right.
9	Entry mode set <input type="text"/>	<input type="text"/>	Set mode for display shift when writing
10	Write data to CG RAM / DD RAM <input type="text"/>	<input type="text"/>	Write " "(space). The cursor is incremented by one and shifted to the right.
11	Write data to CG RAM / DD RAM <input type="text"/>	<input type="text"/>	Write " C ". The cursor is incremented by one and shifted to the right.
12	:	:	
13	Write data to CG RAM / DD RAM <input type="text"/>	<input type="text"/>	Write " Y ". The cursor is incremented by one and shifted to the right.
14	Cursor or display shift <input type="text"/>	<input type="text"/>	Only shift the cursor's position to the left (Y).
15	Cursor or display shift <input type="text"/>	<input type="text"/>	Only shift the cursor's position to the left (M).
16	Write data to CG RAM / DD RAM <input type="text"/>	<input type="text"/>	Write " N ". The display moves to the left.
17	Cursor or display shift <input type="text"/>	<input type="text"/>	Shift the display and the cursor's position to the right.
18	Cursor or display shift <input type="text"/>	<input type="text"/>	Shift the display and the cursor's position to the right.
19	Write data to CG RAM / DD RAM <input type="text"/>	<input type="text"/>	Write " "(space). The cursor is incremented by one and shifted to the right.
20	:	:	
21	Return home <input type="text"/>	<input type="text"/>	Both the display and the cursor return to the original position (address 0).

**5.5. 4-Bit Operation and 8-Digit 1-Line Display (Using Internal Reset)**

No.	Instruction	Display	Operation												
1	Power on. (SPLC783A starts initializing)	<input type="text"/>	Power on reset. No display.												
2	Function set RS R/W DB7 DB6 DB5 DB4 <table border="1"><tr><td>0</td><td>0</td><td>0</td><td>0</td><td>1</td><td>0</td></tr></table>	0	0	0	0	1	0	<input type="text"/>	Set to 4-bit operation.						
0	0	0	0	1	0										
3	<table border="1"><tr><td>0</td><td>0</td><td>0</td><td>0</td><td>1</td><td>0</td></tr><tr><td>0</td><td>0</td><td>0</td><td>0</td><td>X</td><td>X</td></tr></table>	0	0	0	0	1	0	0	0	0	0	X	X	<input type="text"/>	Set to 4-bit operation and select 1-line display line and character font.
0	0	0	0	1	0										
0	0	0	0	X	X										
4	<table border="1"><tr><td>0</td><td>0</td><td>0</td><td>0</td><td>0</td><td>0</td></tr><tr><td>0</td><td>0</td><td>1</td><td>1</td><td>1</td><td>0</td></tr></table>	0	0	0	0	0	0	0	0	1	1	1	0	<input type="text" value="-"/>	Display on. Cursor appears.
0	0	0	0	0	0										
0	0	1	1	1	0										
5	<table border="1"><tr><td>0</td><td>0</td><td>0</td><td>0</td><td>0</td><td>0</td></tr><tr><td>0</td><td>0</td><td>0</td><td>1</td><td>1</td><td>0</td></tr></table>	0	0	0	0	0	0	0	0	0	1	1	0	<input type="text" value="-"/>	Increase address by one. It will shift the cursor to the right when writing to the DD RAM / CG RAM. Now the display has no shift.
0	0	0	0	0	0										
0	0	0	1	1	0										
6	<table border="1"><tr><td>1</td><td>0</td><td>0</td><td>1</td><td>0</td><td>1</td></tr><tr><td>1</td><td>0</td><td>0</td><td>1</td><td>1</td><td>1</td></tr></table>	1	0	0	1	0	1	1	0	0	1	1	1	<input type="text" value="W_"/>	Write " W ". The cursor is incremented by one and shifted to the right.
1	0	0	1	0	1										
1	0	0	1	1	1										

**5.6. 8-Bit Operation and 8-Digit 2-Line Display (Using Internal Reset)**

No.	Instruction	Display	Operation										
1	Power on. (SPLC783A starts initializing)	<input type="text"/>	Power on reset. No display.										
2	Function set RS R/W DB7 DB6 DB5 DB4 DB3 DB2 DB1 DB0 <table border="1"><tr><td>0</td><td>0</td><td>0</td><td>0</td><td>1</td><td>1</td><td>1</td><td>0</td><td>X</td><td>X</td></tr></table>	0	0	0	0	1	1	1	0	X	X	<input type="text"/>	Set to 8-bit operation and select 2-line display line and 5 x 8 dot character font.
0	0	0	0	1	1	1	0	X	X				
3	Display on / off control <table border="1"><tr><td>0</td><td>0</td><td>0</td><td>0</td><td>0</td><td>0</td><td>1</td><td>1</td><td>1</td><td>0</td></tr></table>	0	0	0	0	0	0	1	1	1	0	<input type="text" value="-"/>	Display on. Cursor appear.
0	0	0	0	0	0	1	1	1	0				
4	Entry mode set <table border="1"><tr><td>0</td><td>0</td><td>0</td><td>0</td><td>0</td><td>0</td><td>0</td><td>1</td><td>1</td><td>0</td></tr></table>	0	0	0	0	0	0	0	1	1	0	<input type="text" value="-"/>	Increase address by one. It will shift the cursor to the right when writing to the DD RAM / CG RAM. Now the display has no shift.
0	0	0	0	0	0	0	1	1	0				
5	Write data to CG RAM / DD RAM <table border="1"><tr><td>1</td><td>0</td><td>0</td><td>1</td><td>0</td><td>1</td><td>0</td><td>1</td><td>1</td><td>1</td></tr></table>	1	0	0	1	0	1	0	1	1	1	<input type="text" value="W_"/>	Write " W ". The cursor is incremented by one and shifted to the right.
1	0	0	1	0	1	0	1	1	1				
6	:	:	:										
7	Write data to CG RAM / DD RAM <table border="1"><tr><td>1</td><td>0</td><td>0</td><td>1</td><td>0</td><td>0</td><td>0</td><td>1</td><td>0</td><td>1</td></tr></table>	1	0	0	1	0	0	0	1	0	1	<input type="text" value="WELCOME_"/>	Write " E ". The cursor is incremented by one and shifted to the right.
1	0	0	1	0	0	0	1	0	1				
8	Set DD RAM address <table border="1"><tr><td>0</td><td>0</td><td>1</td><td>1</td><td>0</td><td>0</td><td>0</td><td>0</td><td>0</td><td>0</td></tr></table>	0	0	1	1	0	0	0	0	0	0	<input type="text" value="WELCOME"/> <input type="text" value="-"/>	It sets DD RAM's address. The cursor is moved to the beginning position of the 2nd line.
0	0	1	1	0	0	0	0	0	0				
9	Write data to CG RAM / DD RAM <table border="1"><tr><td>1</td><td>0</td><td>0</td><td>1</td><td>0</td><td>1</td><td>0</td><td>1</td><td>0</td><td>0</td></tr></table>	1	0	0	1	0	1	0	1	0	0	<input type="text" value="WELCOME"/> <input type="text" value="T_"/>	Write " T ". The cursor is incremented by one and shifted to the right.
1	0	0	1	0	1	0	1	0	0				
10	:	:	:										
11	Write data to CG RAM / DD RAM <table border="1"><tr><td>1</td><td>0</td><td>0</td><td>1</td><td>0</td><td>1</td><td>0</td><td>1</td><td>0</td><td>0</td></tr></table>	1	0	0	1	0	1	0	1	0	0	<input type="text" value="WELCOME"/> <input type="text" value="TO PART_"/>	Write " T ". The cursor is incremented by one and shifted to the right.
1	0	0	1	0	1	0	1	0	0				

No.	Instruction	Display	Operation
12	Entry mode set 0 0 0 0 0 0 0 1 1 1	WELCOME TO PART_	When writing, it sets mode for the display shift.
13	Write data to CG RAM / DD RAM 1 0 0 1 0 1 1 0 0 1	ELCOME O PARTY_	Write " Y ". The cursor is incremented by one and shifted to the right.
14	:	:	:
15	Return home 0 0 0 0 0 0 0 0 1 0	WELCOME TO PARTY	Both the display and the cursor return to the original position (address 0).

### 5.7. RESET Function

At power on, SPLC783A starts the internal auto-reset circuit and executes the initial instructions. The initial procedures are shown as follows:

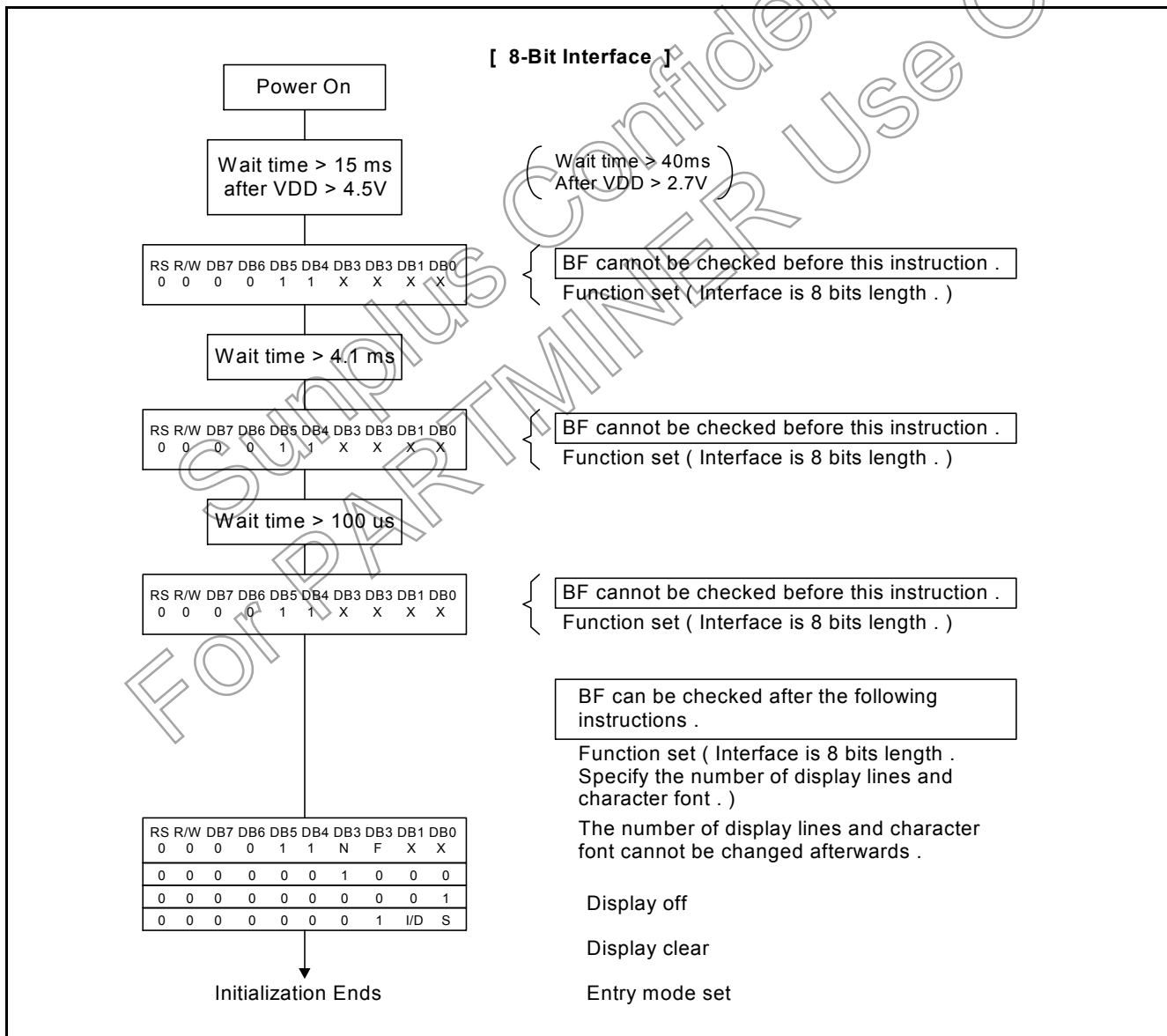

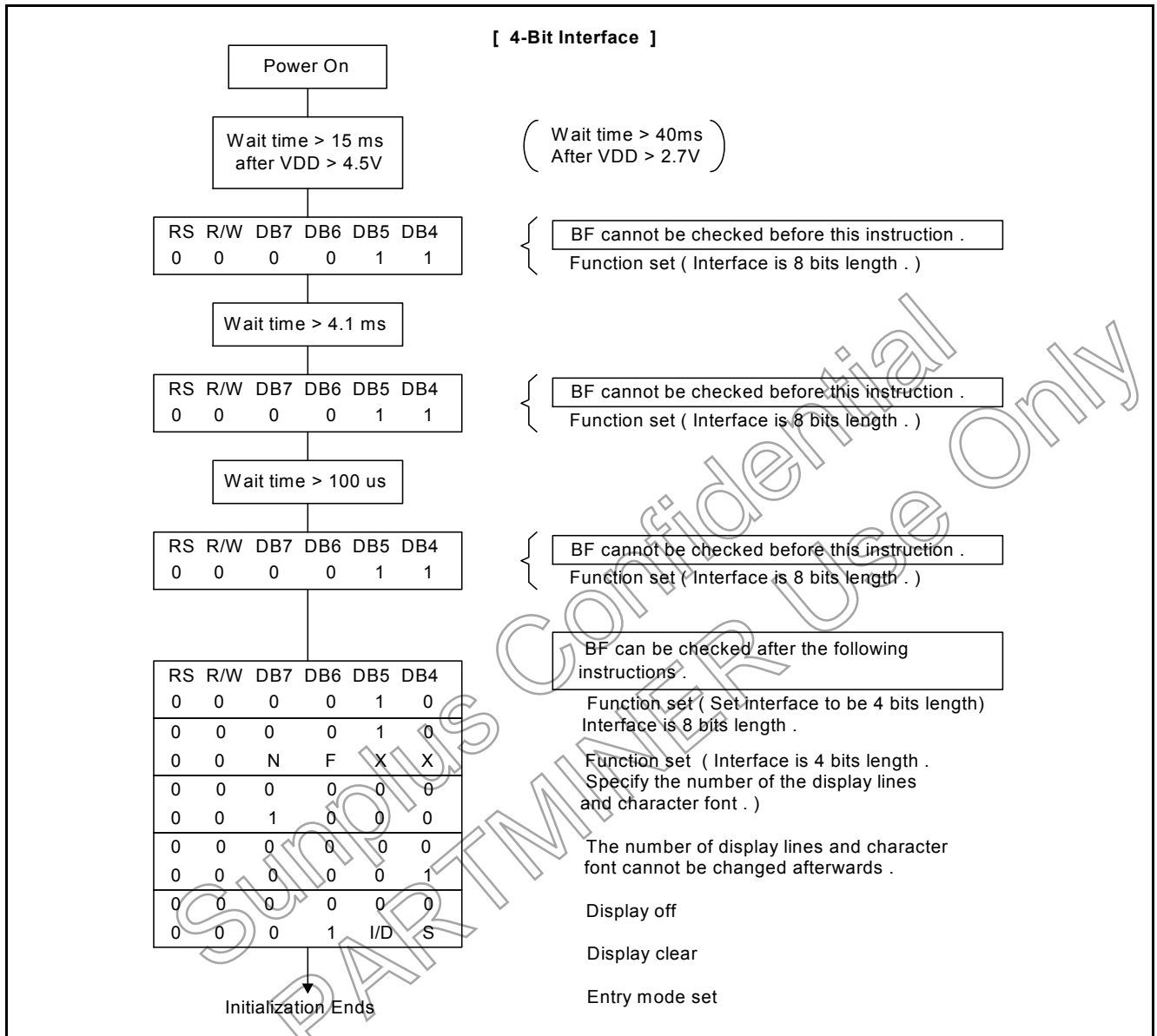

### 5.8. Display Data RAM (DD RAM)

The 80-bit DD RAM is normally used for storing display data. Those DD RAM not used for display data can be used as general data RAM. Its address is configured in the Address Counter.

The relationships between Display Data RAM Address and LCD's position are depicted as follows.

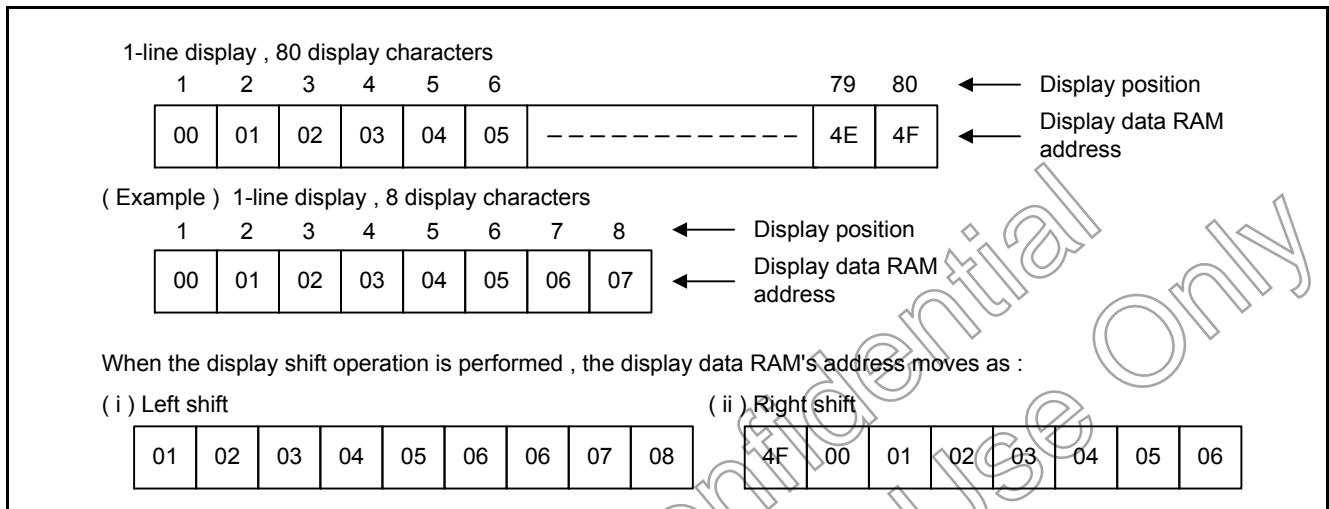

### 5.9. Timing Generation Circuit

The timing generating circuit is able to generate timing signals to the internal circuits. In order to prevent the internal timing interface, the MPU access timing and the RAM access timing are generated independently.

### 5.10. LCD Driver Circuit

Total of 16 commons and 80 segments signal drivers are valid in the LCD driver circuit. When a program specifies the character fonts and line numbers, the corresponding common signals output drive-waveforms and the others still output unselected waveforms.

### 5.11. Character Generator ROM (CG ROM)

Using 8-bit character code, the character generator ROM generates 5 x 8 dots or 5 x 10 dots character patterns. It also can generate 192's 5 x 8 dots character patterns and 64's 5 x 10 dots character patterns.

### 5.12. Character Generator RAM (CG RAM)

Users can easily change the character patterns in the character generator RAM through program. It can be written to 5 x 8 dots, 8-character patterns or 5 x 10 dots for 4-character patterns.

The following diagram shows the SPLC783A character patterns:

Correspondence between Character Codes and Character Patterns.

		Higher 4-bit (D4 to D7) of Character Code (Hexadecimal)																
		0	1	2	3	4	5	6	7	8	9	A	B	C	D	E	F	
Lower 4-bit (D0 to D3) of Character Code (Hexadecimal)	0	CG RAM (1)																
	1	CG RAM (2)																
	2	CG RAM (3)																
	3	CG RAM (4)																
	4	CG RAM (5)																
	5	CG RAM (6)																
	6	CG RAM (7)																
	7	CG RAM (8)																
	8	CG RAM (1)																
	9	CG RAM (2)																
	A	CG RAM (3)																
	B	CG RAM (4)																
	C	CG RAM (5)																
	D	CG RAM (6)																
	E	CG RAM (7)																
	F	CG RAM (8)																

The relationships between Character Generator RAM Addresses, Character Generator RAM Data (character patterns), and Character Codes are depicted as follows:



**1. 5 x 8 dot character patterns**

Character Code (DD RAM Data)								CG RAM Address						Character Patterns (CG RAM Data)											
b7	b6	b5	b4	b3	b2	b1	b0	b5	b4	b3	b2	b1	b0	b7	b6	b5	b4	b3	b2	b1	b0				
0	0	0	0	X	0	0	0	0	0	0	0	0	0	1	1	1	X	X	X	1	1	1	1	1	1
											0	0	1	0	0	0				0	0	1	0	0	
											0	1	0	0	0	0				0	0	1	0	0	
											0	1	1	0	0	0				0	0	1	0	0	
											1	0	0	0	0	0				0	0	1	0	0	
											1	0	1	0	0	0				0	0	1	0	0	
											1	1	0	0	0	0				0	0	1	0	0	
											1	1	1	0	0	0				0	0	0	0	0	
0	0	0	0	X	0	0	1	0	0	1	0	0	0	0	0	0	X	X	X	0	1	1	1	1	0
											0	0	1	0	0	0				0	0	1	0	0	
											0	1	0	0	0	0				0	0	1	0	0	
											0	1	1	0	0	0				0	0	1	0	0	
											1	0	0	0	0	0				0	0	1	0	0	
											1	0	1	0	0	0				0	0	1	0	0	
											1	1	0	0	0	0				0	1	1	1	0	
											1	1	1	0	0	0				0	0	0	0	0	

Character Pattern Example (1)

Cursor Position ←

Character Pattern Example (2)

- Note1:**  It means that the bit0~2 of the character code correspond to the bit3~5 of the CG RAM address.
- Note2:**  These areas are not used for display, but can be used for the general data RAM.
- Note3:** When all of the bit4~7 of the character code are 0, CG RAM character patterns are selected.
- Note4:** " 1 " : Selected , " 0 " : No selected , " X " : Do not care (0 or 1).
- Note5:** For example (1), set character code (b2 = b1 = b0 = 0, b3 = 0 or 1, b7-b4 = 0) to display " T ". That means character code (00) 16, and (08) 16 can display " T " character.
- Note6:** The bits 0-2 of the character code RAM is the character pattern line position. The 8th line is the cursor position and display is formed by logical OR with the cursor.





**2). 5 X 10 dot character patterns**

Character Code ( DD RAM Data )								CG RAM Address						Character Patterns ( CG RAM Data )							
b7	b6	b5	b4	b3	b2	b1	b0	b5	b4	b3	b2	b1	b0	b7	b6	b5	b4	b3	b2	b1	b0
										0	0	0	0								
										0	0	0	1								
										0	0	1	0								
										0	0	1	1								
										0	1	0	0								
0	0	0	0	X	0	0	X	0	0	0	1	0	1	X	X	X	1	0	0	0	1
										0	1	1	0								
										0	1	1	1								
										1	0	0	0								
										1	0	0	1								
										1	0	1	0								
										1	0	1	1								
										1	1	0	0								
										1	1	0	1	X	X	X	X	X	X	X	X
										1	1	1	0								
										1	1	1	1								

Character Pattern Example (1)

Cursor Position ←

- Note1:**  It means that the bit1~2 of the character code correspond to the bit4~5 of the CG RAM address.
- Note2:**  These areas are not used for display, but can be used for the general data RAM.
- Note3:** When all of the bit4-7 of the character code are 0, CG RAM character patterns are selected.
- Note4:** " 1 ": Selected, " 0 ": No selected, " X ": Do not care (0 or 1).
- Note5:** For example (1), set character code (b2 = b1 = 0, b3 = b0 = 0 or 1, b7-b4 = 0) to display " U ". That means all of the character codes (00) 16, (01) 16, (08) 16, and (09) 16 can display " U " character.
- Note6:** The bits 0-3 of the character code RAM is the character pattern line position. The 11th line is the cursor position and display is formed by logical OR with the cursor.

**5.13. Cursor/Blink Control Circuit**

This circuit generates the cursor or blink in the cursor / blink control circuit. The cursor or the blink appears in the digit at the Display Data RAM Address defined in the Address Counter.

When the Address Counter is (07) 16, the cursor position is shown as belows:

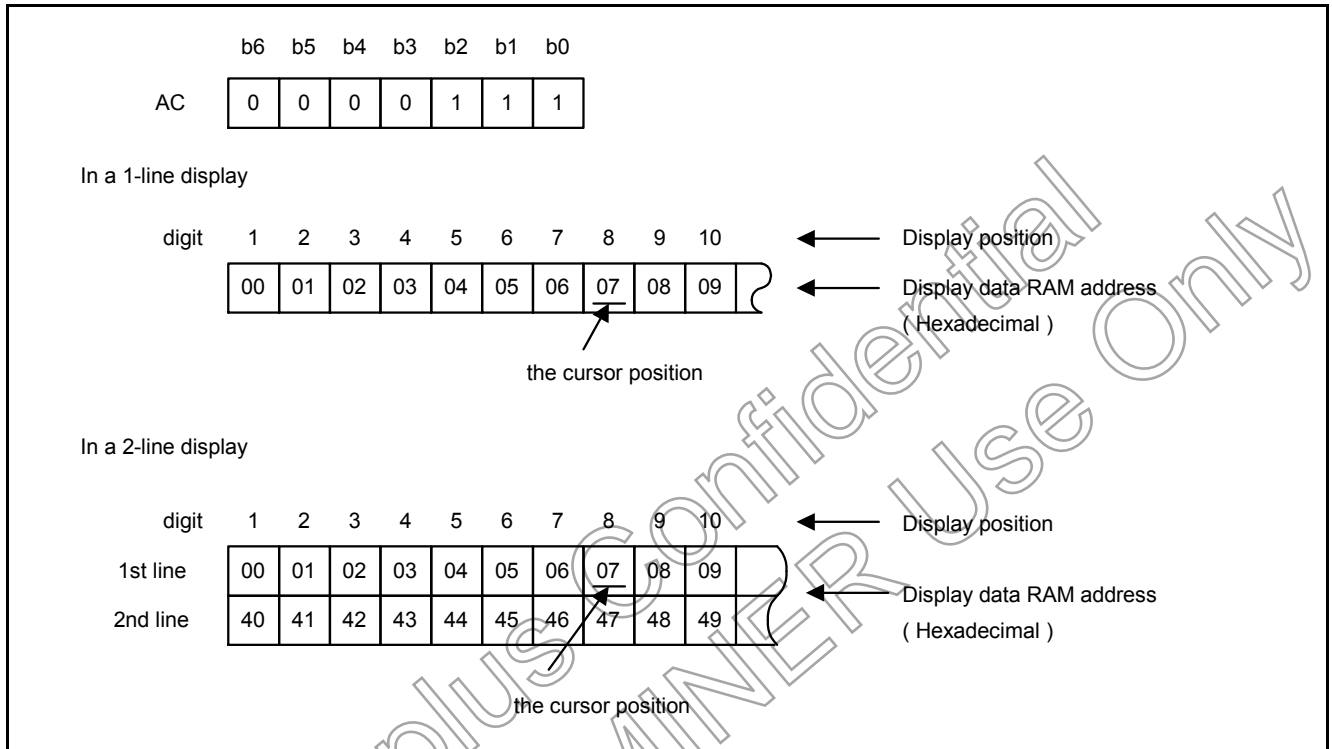

**5.14. Interfacing to MPU**

There are two types of data operations: 4-bit and 8-bit operations. Using 4-bit MPU, the interfacing 4-bit data is transferred by 4-busline (DB4 to DB7). Thus, DB0 to DB3 bus lines are not used. Using 4-bit MPU to interface 8-bit data requires two times transferring. First, the higher 4-bit data is transferred by

4-busline (for 8-bit operation, DB7 to DB4). Secondly, the lower 4-bit data is transferred by 4-busline (for 8-bit operation, DB3 to DB0). For 8-bit MPU, the 8-bit data is transferred by 8-buslines (DB0 to DB7).

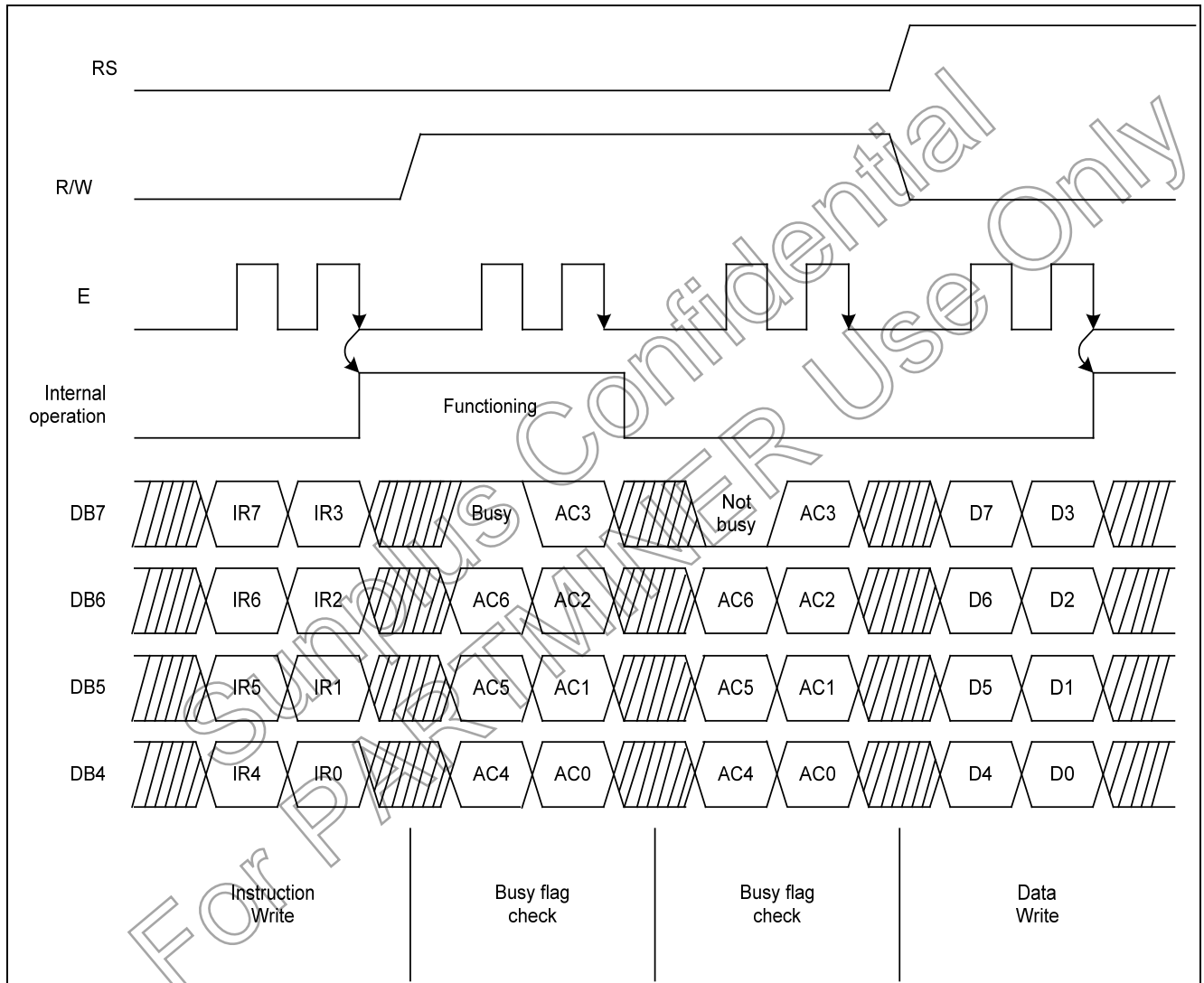

Example of 4-bit Data Transfer Timing Sequence

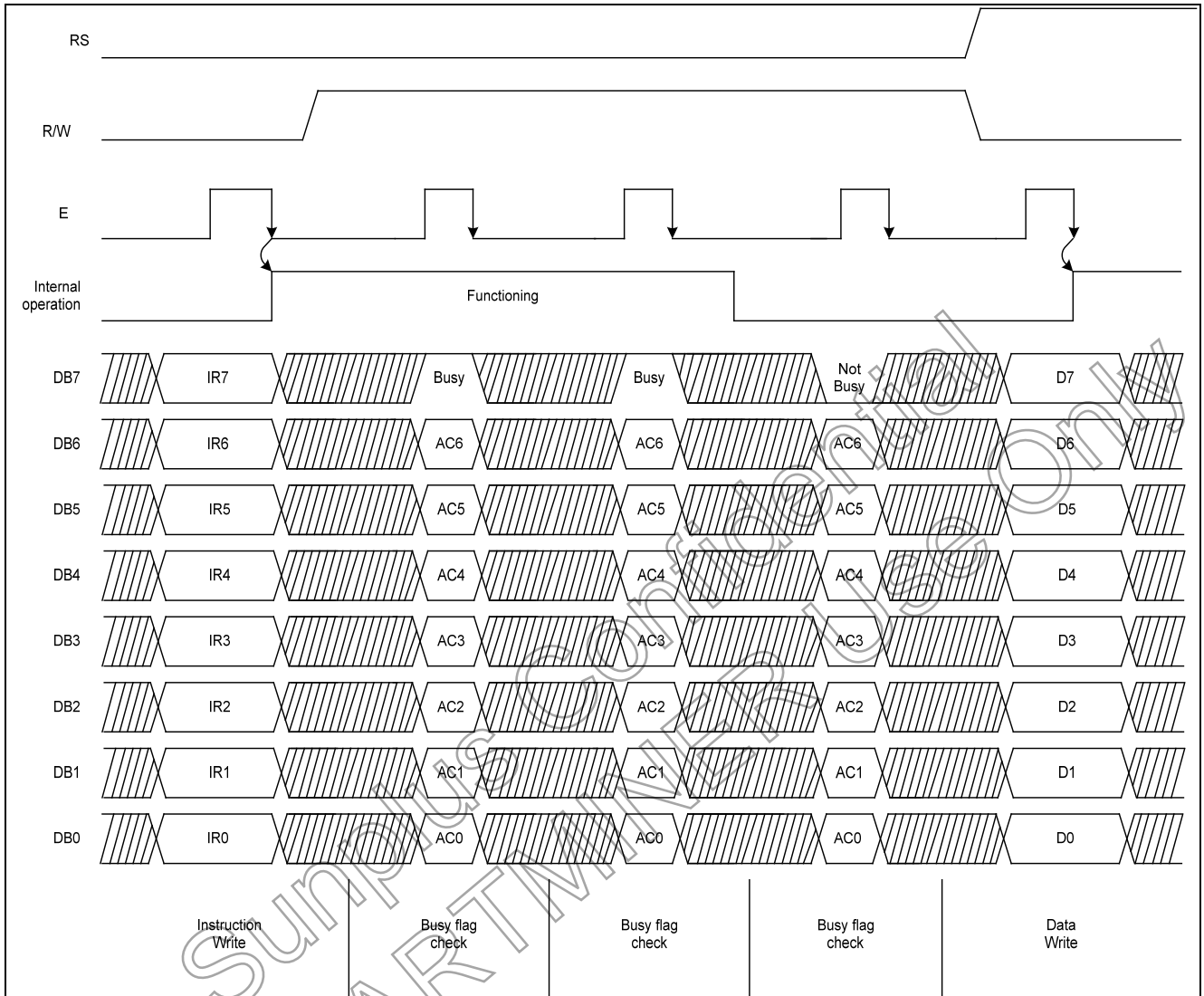

Example of 8-bit Data Transfer Timing Sequence

### 5.15. Supply Voltage for LCD Drive

Different voltages can be supplied to SPLC783A's pins (V5 - 1) for obtaining LCD drive-waveform. The relationships between bias, duty factor and supply voltages are shown as follows:

Supply Voltage	Duty Factor	1/8, 1/11	1/16
		1/4	1/5
V1		$VDD - 1/4 V_{LCD}$	$VDD - 1/5 V_{LCD}$
V2		$VDD - 1/2 V_{LCD}$	$VDD - 2/5 V_{LCD}$
V3		$VDD - 1/2 V_{LCD}$	$VDD - 3/5 V_{LCD}$
V4		$VDD - 3/4 V_{LCD}$	$VDD - 4/5 V_{LCD}$
V5		$VDD - V_{LCD}$	$VDD - V_{LCD}$

5.15.1. The power connections for LCD (1/4 Bias, 1/5 Bias) are shown belows:

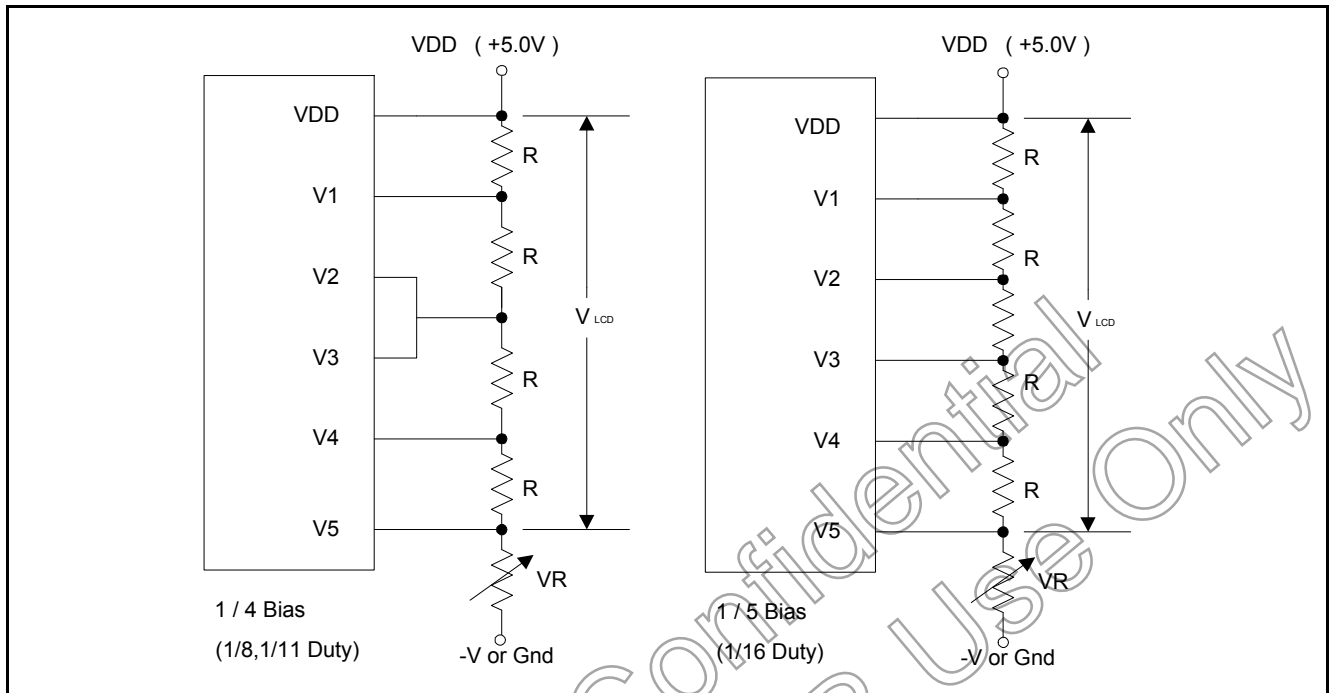

The bypass-capacitor improves the LCD display quality.

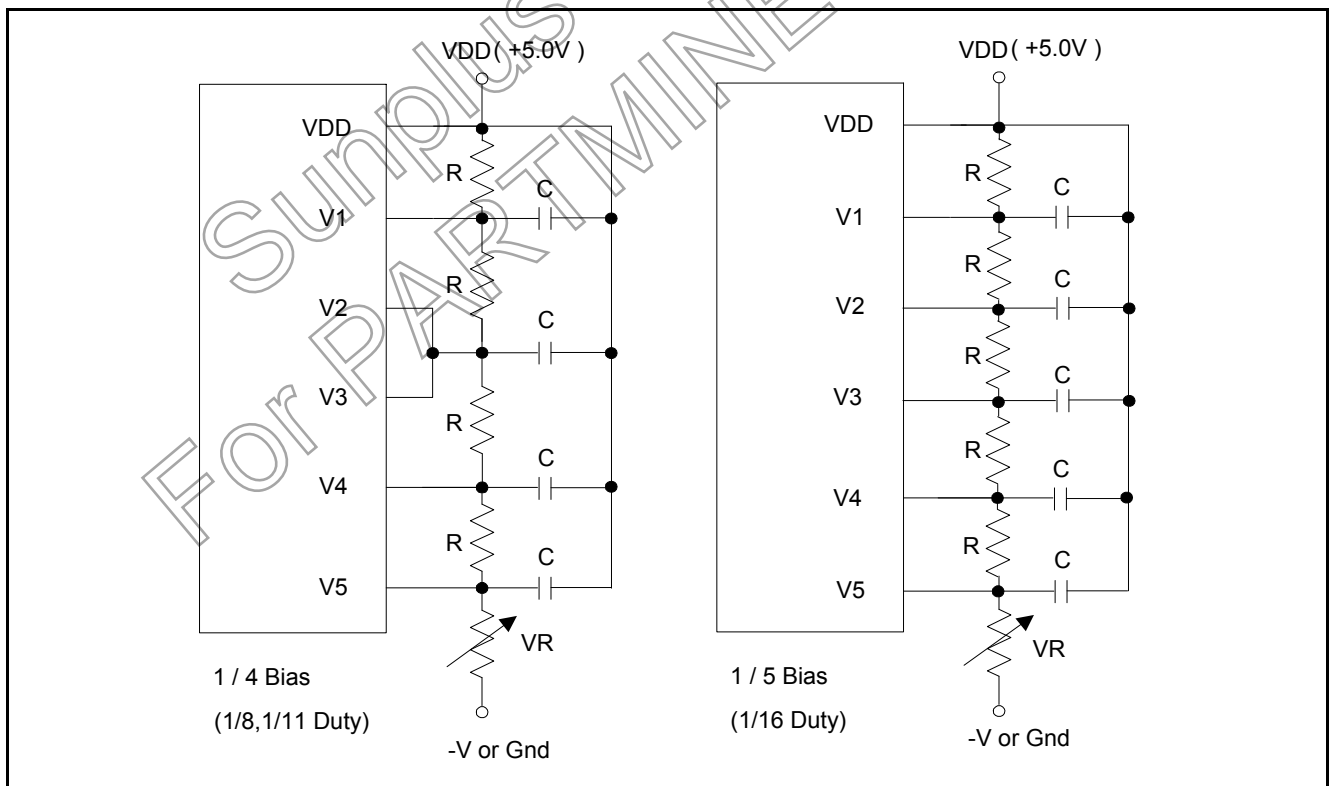

The bias voltage must have the following relations:

$$VDD > V1 > V2 \geq V3 > V4 > V5.$$

**5.15.2. The relationship between LCD frame's frequency and oscillator's frequency.**

(Assume the oscillation frequency is 250KHz, 1 clock cycle time = 4.0μs)

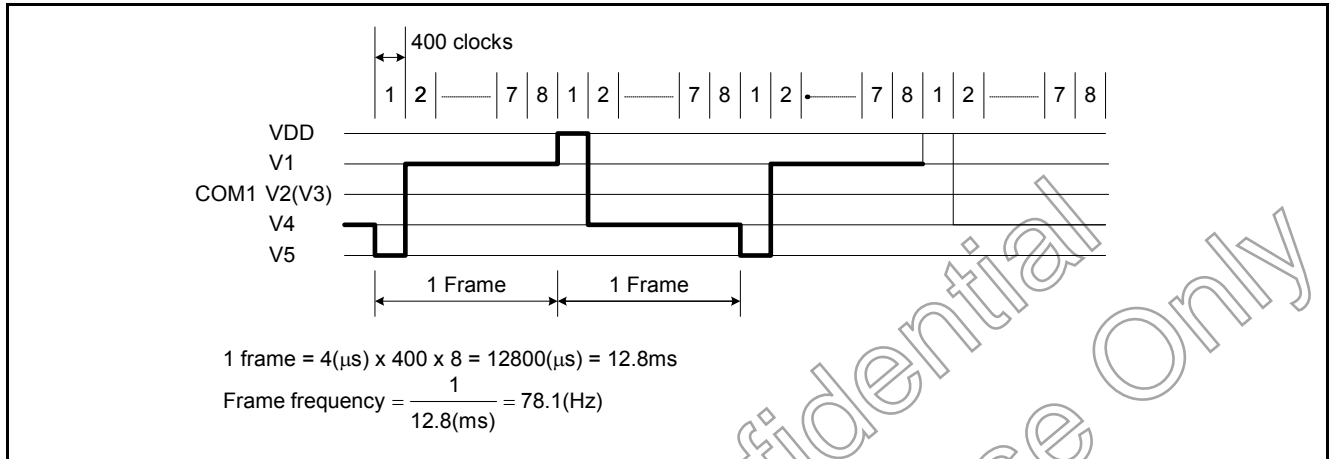
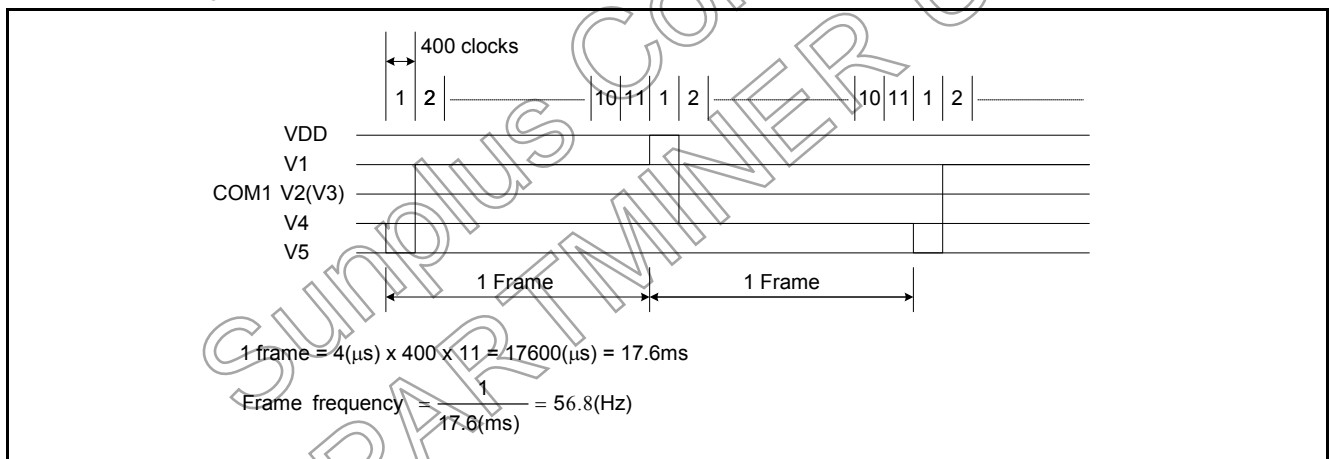
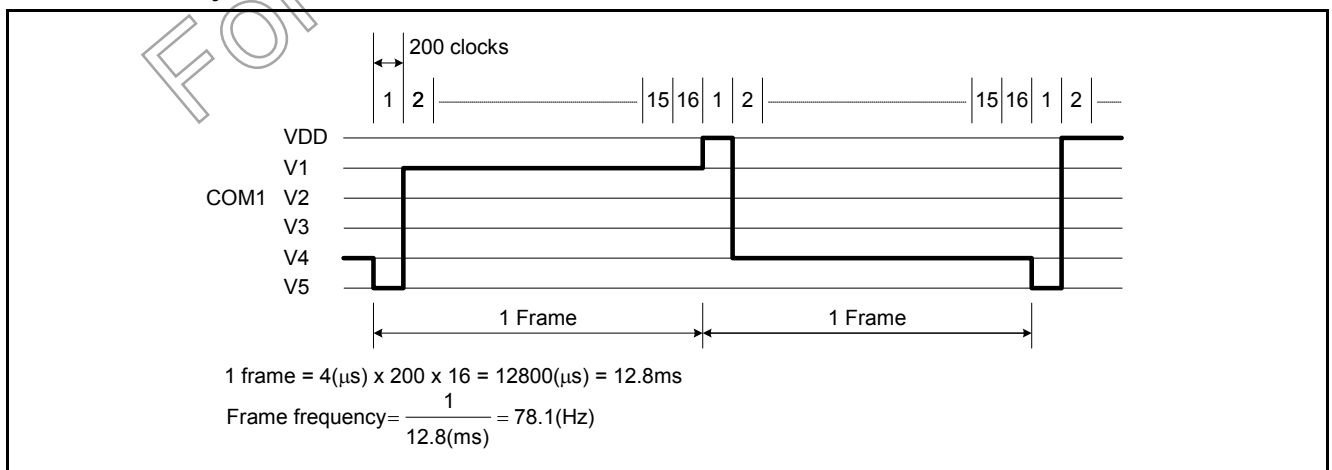
**5.15.2.1. 1/8 duty, TYPE-B waveform**

**5.15.2.2. 1/11 duty, TYPE-B waveform**

**5.15.2.3. 1/16 duty, TYPE-B waveform**

### 5.16. REGISTER --- IR (Instruction Register) and DR (Data Register)

SPLC783A contains two 8-bit registers: Instruction Register (IR) and Data Register (DR). Using combinations of the RS pin and the R/W pin selects the IR and DR, see below:

RS	R/W	Operation
0	0	IR write (Display clear, etc.)
0	1	Read busy flag (DB7) and Address Counter (DB0 - DB6)
1	0	DR write (DR to Display data RAM or Character generator RAM)
1	1	DR read (Display data RAM or Character generator RAM to DR)

The IR can be written by MPU, but it cannot be read by MPU.

### 5.17. Busy Flag (BF)

When RS = 0 and R/W = 1, the busy flag is output to DB7. As the busy flag = 1, SPLC783A is in busy state and does not accept any instruction until the busy flag = 0.

### 5.18. Address Counter (AC)

The Address Counter assigns addresses to Display Data RAM and Character Generator RAM. When an instruction for address is written in IR, the address information is sent from IR to AC. After writing to/reading from Display Data RAM or Character Generator RAM, AC is automatically incremented by one (or decremented by one). The contents of AC are output to DB0 - DB6 when RS = 0 and R/W = 1.

### 5.19. I/O Port Configuration

#### 5.19.1. Input port: E

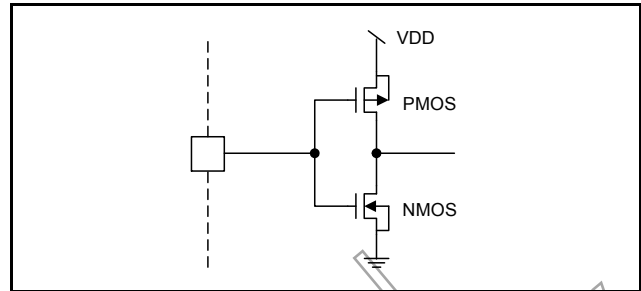

#### 5.19.2. Input port: R / W, RS

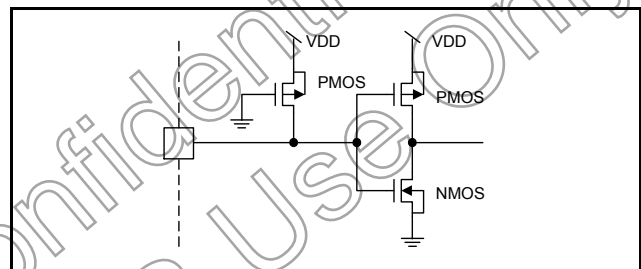

#### 5.19.3. Output port: CLK1, CLK2, M, D

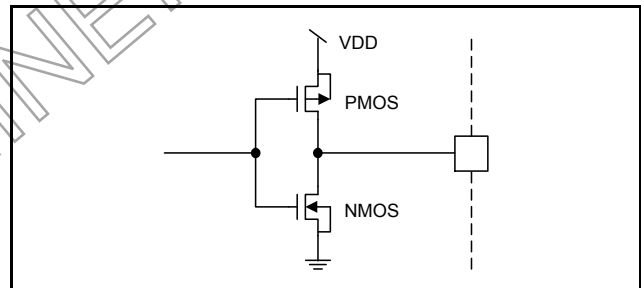

#### 5.19.4. Input / Output port: DB7 - 0

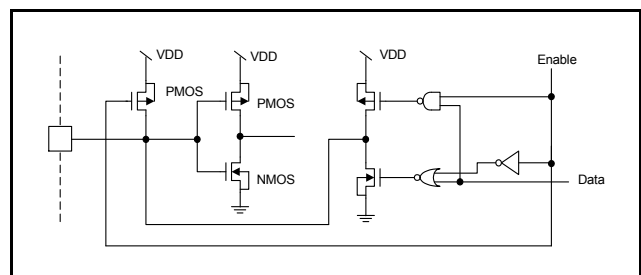

## 6. ELECTRICAL SPECIFICATIONS

### 6.1. Absolute Maximum Ratings

Characteristics	Symbol	Ratings
Operating Voltage	VDD	-0.3V to +7.0V
Driver Supply Voltage	V <sub>LCD</sub>	VDD - 12V to VDD + 0.3V
Input Voltage Range	V <sub>IN</sub>	-0.3V to VDD + 0.3V
Operating Temperature	T <sub>A</sub>	-30°C to +80°C
Storage Temperature	T <sub>STO</sub>	-55°C to +125°C

**Note:** Stresses beyond those given in the Absolute Maximum Rating table may cause operational errors or damage to the device. For normal operational conditions see AC/DC Electrical Characteristics.

### 6.2. DC Characteristics (VDD = 2.7V to 4.5V, T<sub>A</sub> = 25°C)

Characteristics	Symbol	Limit			Unit	Test Condition
		Min.	Typ.	Max.		
Operating Current	I <sub>DD</sub>	-	0.2	0.4	mA	External clock (Note)
Input High Voltage	V <sub>IH1</sub>	0.7VDD	-	VDD	V	Pins:(E, RS, R/W, DB0 - DB7)
Input Low Voltage	V <sub>IL1</sub>	-0.3	-	0.4	V	
Input High Voltage	V <sub>IH2</sub>	0.7VDD	-	VDD	V	Pin OSC1
Input Low Voltage	V <sub>IL2</sub>	-0.2	-	0.2VDD	V	
Input High Current	I <sub>IH</sub>	-1.0	-	1.0	μA	Pins: (RS, R/W, DB0 - DB7) VDD = 3.0V
Input Low Current	I <sub>IL</sub>	-5.0	-15	-30	μA	
Output High Voltage (TTL)	V <sub>OH1</sub>	2.0	-	-	V	I <sub>OH</sub> = - 0.1mA Pins: DB0 - DB7
Output Low Voltage (TTL)	V <sub>OL1</sub>	-	-	0.2VDD	V	I <sub>OL</sub> = 0.1mA Pins: DB0 - DB7
Output High Voltage (CMOS)	V <sub>OH2</sub>	0.8VDD	-	-	V	I <sub>OH</sub> = - 40μA, Pins: CLK1, CLK2, M, D
Output Low Voltage (CMOS)	V <sub>OL2</sub>	-	-	0.2VDD	V	I <sub>OL</sub> = 40μA, Pins: CLK1, CLK2, M, D
Driver ON Resistance (COM)	R <sub>COM</sub>	-	-	10	KΩ	I <sub>O</sub> = ±50μA, V <sub>LCD</sub> = 4.0V Pins: COM1 - COM16
Driver ON Resistance (SEG)	R <sub>SEG</sub>	-	-	15	KΩ	I <sub>O</sub> = ±50μA, V <sub>LCD</sub> = 4.0V Pins: SEG1 - SEG80
LCD Voltage	V <sub>LCD</sub>	3.0	-	11	V	VDD-V5, 1/4 bias or 1/5 bias

**Note:** F<sub>OSC</sub> = 270KHz, VDD = 3.0V, pin E = "L", RS, R/W, DB0 - DB7 are open, all outputs are no loads.



**6.3. AC Characteristics (VDD = 2.7V to 4.5V, T<sub>A</sub> = 25°C)**
**6.3.1. Internal clock operation**

Characteristics	Symbol	Limit			Unit	Test Condition
		Min.	Typ.	Max.		
OSC Frequency	F <sub>OSC1</sub>	190	270	350	KHz	VDD = 3.0V, Rf = 75KΩ±2%

**6.3.2. External clock operation**

Characteristics	Symbol	Limit			Unit	Test Condition
		Min.	Typ.	Max.		
External Frequency	F <sub>OSC2</sub>	125	250	350	KHz	
Duty Cycle		45	50	55	%	
Rise/Fall Time	t <sub>r</sub> , t <sub>f</sub>	-	-	0.2	μs	

**6.3.3. Write mode (Writing data from MPU to SPLC783A)**

Characteristics	Symbol	Limit			Unit	Test Condition
		Min.	Typ.	Max.		
E Cycle Time	t <sub>C</sub>	1400	-	-	ns	Pin E
E Pulse Width	t <sub>PW</sub>	400	-	-	ns	Pin E
E Rise/Fall Time	t <sub>R</sub> , t <sub>F</sub>	-	-	25	ns	Pin E
Address Setup Time	t <sub>SP1</sub>	60	-	-	ns	Pins: RS, R/W, E
Address Hold Time	t <sub>HD1</sub>	20	-	-	ns	Pins: RS, R/W, E
Data Setup Time	t <sub>SP2</sub>	140	-	-	ns	Pins: DB0 - DB7
Data Hold Time	t <sub>HD2</sub>	10	-	-	ns	Pins: DB0 - DB7

**6.3.4. Read mode (Reading data from SPLC783A to MPU)**

Characteristics	Symbol	Limit			Unit	Test Condition
		Min.	Typ.	Max.		
E Cycle Time	t <sub>C</sub>	1400	-	-	ns	Pin E
E Pulse Width	t <sub>W</sub>	400	-	-	ns	Pin E
E Rise/Fall Time	t <sub>R</sub> , t <sub>F</sub>	-	-	25	ns	Pin E
Address Setup Time	t <sub>SP1</sub>	60	-	-	ns	Pins: RS, R/W, E
Address Hold Time	t <sub>HD1</sub>	20	-	-	ns	Pins: RS, R/W, E
Data Output Delay Time	t <sub>D</sub>	-	-	360	ns	Pins: DB0 - DB7
Data hold time	t <sub>HD2</sub>	5.0	-	-	ns	Pin DB0 - DB7

**6.4. DC Characteristics (VDD = 4.5V to 5.5V, TA = 25°C)**

Characteristics	Symbol	Limit			Unit	Test Condition
		Min.	Typ.	Max.		
Operating Current	I <sub>DD</sub>	-	0.4	0.6	mA	External clock (Note)
Input High Voltage	V <sub>IH1</sub>	2.2	-	VDD	V	Pins:(E, RS, R/W, DB0 - DB7)
Input Low Voltage	V <sub>IL1</sub>	-0.3	-	0.6	V	
Input High Voltage	V <sub>IH2</sub>	VDD-1	-	VDD	V	Pin OSC1
Input Low Voltage	V <sub>IL2</sub>	-0.2	-	1.0	V	Pin OSC1
Input High Current	I <sub>IH</sub>	-1.0	-	1.0	μA	Pins: (RS, R/W, DB0 - DB7) VDD = 5.0V
Input Low Current	I <sub>IL</sub>	-20	-50	-100	μA	
Output High Voltage (TTL)	V <sub>OH1</sub>	2.4	-	VDD	V	I <sub>OH</sub> = -0.205mA Pins: DB0 - DB7
Output Low Voltage (TTL)	V <sub>OL1</sub>	-	-	0.4	V	I <sub>OL</sub> = 1.2mA Pins: DB0 - DB7
Output High Voltage (CMOS)	V <sub>OH2</sub>	0.9VDD	-	VDD	V	I <sub>OH</sub> = -40μA, Pins: CLK1, CLK2, M, D
Output Low Voltage (CMOS)	V <sub>OL2</sub>	-	-	0.1VDD	V	I <sub>OL</sub> = 40μA, Pins: CLK1, CLK2, M, D
Driver ON Resistance (COM)	R <sub>COM</sub>	-	-	10K	KΩ	I <sub>O</sub> = ±50μA, V <sub>LCD</sub> = 4.0V Pins: COM1 - COM16
Driver ON Resistance (SEG)	R <sub>SEG</sub>	-	-	15K	KΩ	I <sub>O</sub> = ±50μA, V <sub>LCD</sub> = 4.0V Pins: SEG1 - SEG80
LCD Voltage	V <sub>LCD</sub>	3.0	-	11	V	VDD-V5, 1/4 bias or 1/5 bias

Note: F<sub>OSC</sub> = 270KHz, VDD = 5.0V, pin E = "L", RS, R/W, DB0 - DB7 are open, all outputs are no loads.

**6.5. AC Characteristics (VDD = 4.5V to 5.5V, TA = 25°C)**
**6.5.1. Internal clock operation**

Characteristics	Symbol	Limit			Unit	Test Condition
		Min.	Typ.	Max.		
OSC Frequency	F <sub>OSC1</sub>	190	270	350	KHz	VDD = 5.0V, Rf = 91KΩ±2%

**6.5.2. External clock operation**

Characteristics	Symbol	Limit			Unit	Test Condition
		Min.	Typ.	Max.		
External Frequency	F <sub>OSC2</sub>	125	250	350	KHz	
Duty Cycle		45	50	55	%	
Rise/Fall Time	tr, tf	-	-	0.2	μs	

**6.5.3. Write mode (Writing Data from MPU to SPLC783A)**

Characteristics	Symbol	Limit			Unit	Test Condition
		Min.	Typ.	Max.		
E Cycle Time	$t_C$	500	-	-	ns	Pin E
E Pulse Width	$t_{PW}$	220	-	-	ns	Pin E
E Rise/Fall Time	$t_R, t_F$	-	-	25	ns	Pin E
Address Setup Time	$t_{SP1}$	40	-	-	ns	Pins: RS, R/W, E
Address Hold Time	$t_{HD1}$	10	-	-	ns	Pins: RS, R/W, E
Data Setup Time	$t_{SP2}$	60	-	-	ns	Pins: DB0 - DB7
Data Hold Time	$t_{HD2}$	10	-	-	ns	Pins: DB0 - DB7

**6.5.4. Read mode (Reading Data from SPLC783A to MPU)**

Characteristics	Symbol	Limit			Unit	Test Condition
		Min.	Typ.	Max.		
E Cycle Time	$t_C$	500	-	-	ns	Pin E
E Pulse Width	$t_W$	220	-	-	ns	Pin E
E Rise/Fall Time	$t_R, t_F$	-	-	25	ns	Pin E
Address Setup Time	$t_{SP1}$	40	-	-	ns	Pins: RS, R/W, E
Address Hold Time	$t_{HD1}$	10	-	-	ns	Pins: RS, R/W, E
Data Output Delay Time	$t_D$	-	-	120	ns	Pins: DB0 - DB7
Data hold time	$t_{HD2}$	20	-	-	ns	Pin DB0 - DB7

**6.5.5. Interface mode with LCD Driver (SPLC100A1)**

Characteristics	Symbol	Limit			Unit	Test Condition
		Min.	Typ.	Max.		
Clock pulse width high	$t_{PWH}$	800	-	-	ns	Pins: CLK1, CLK2
Clock pulse width low	$t_{PWL}$	800	-	-	ns	Pins: CLK1, CLK2
Clock setup time	$t_{CSP}$	500	-	-	ns	Pins: CLK1, CLK2
Data setup time	$t_{DSP}$	300	-	-	ns	Pins: D
Data hold time	$t_{HD}$	300	-	-	ns	Pins: D
M delay time	$t_D$	-1000	-	1000	ns	Pins: M

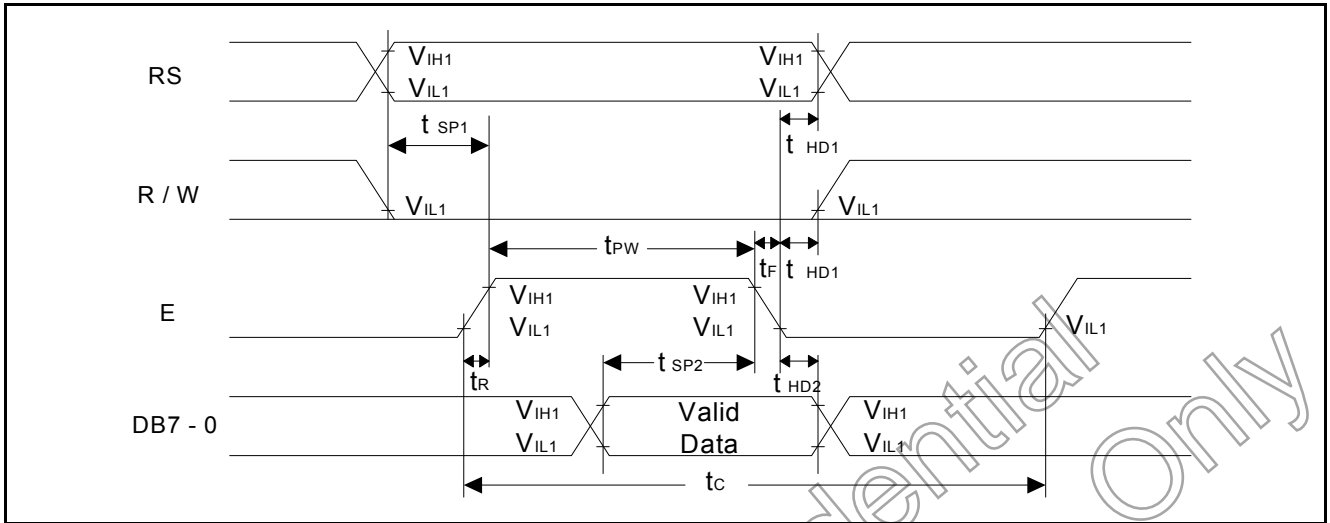
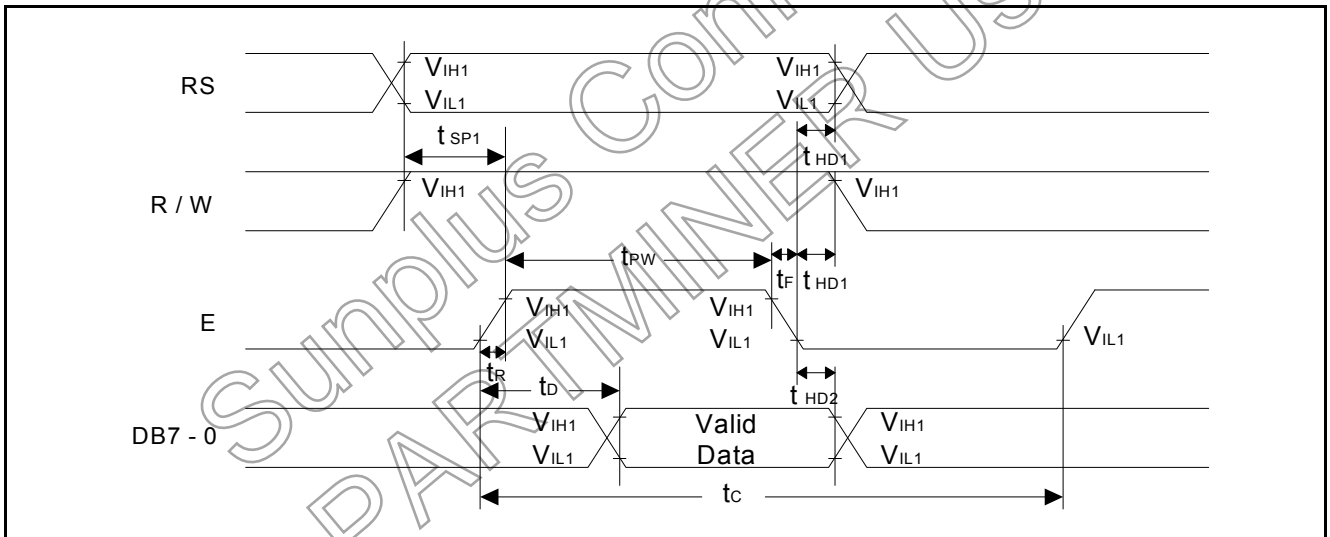
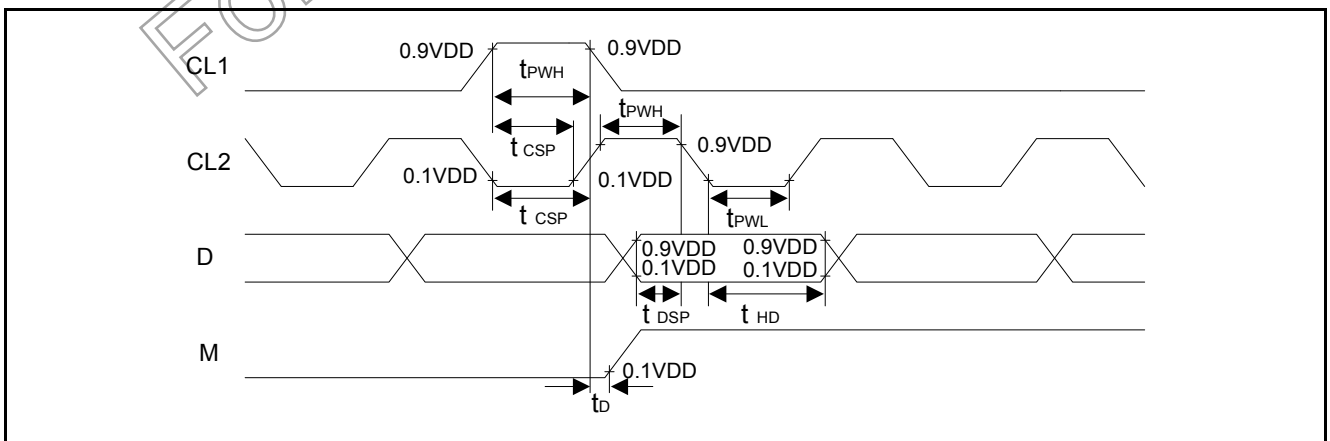
**6.5.6. Write mode timing diagram (Writing Data from MPU to SPLC783A)**

**6.5.7. Read mode timing diagram (Reading Data from SPLC783A to MPU)**

**6.5.8. Interface mode with SPLC100A1 timing diagram**

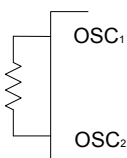
**7. APPLICATION CIRCUITS**
**7.1. R-Oscillator**

The oscillation resistor  $R_f$  is used only for the internal oscillator operation mode.



$R_f$  : 75K $\Omega$   $\pm$  2% ( when VDD = 3.0V )  
 $R_f$  : 91K $\Omega$   $\pm$  2% ( when VDD = 5.0V )

Since the oscillation frequency varies depending on the OSC<sub>1</sub> and OSC<sub>2</sub> pin capacitance, the wiring length to these pins should be minimized.

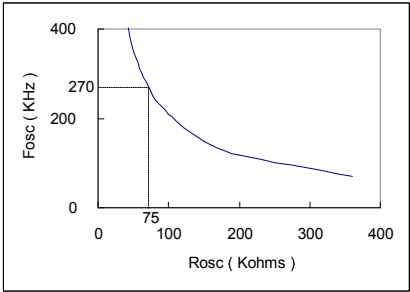

VDD = 3.0V

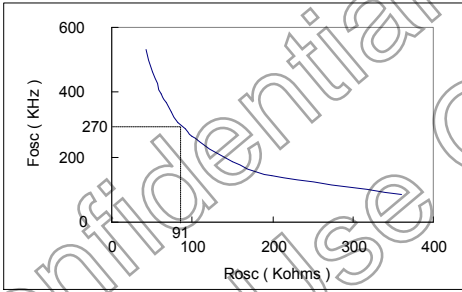

VDD = 5.0V

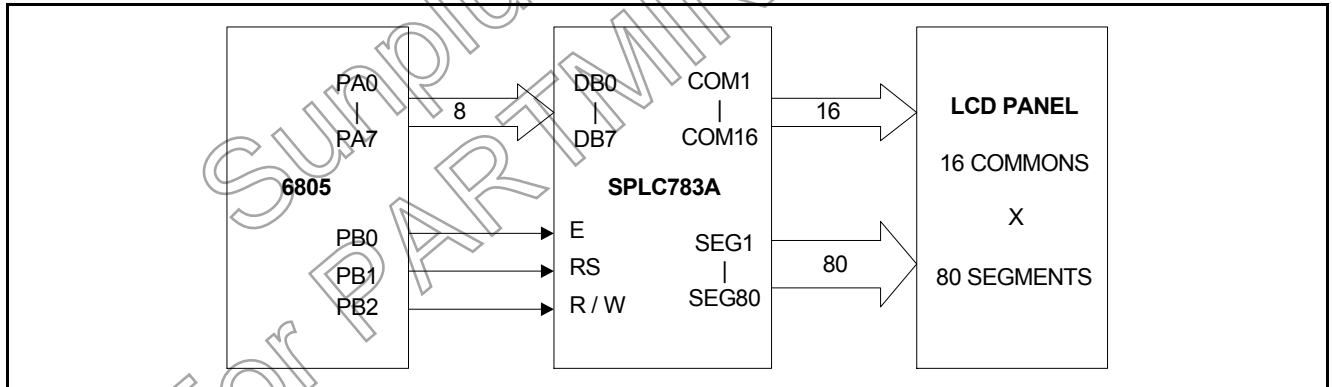
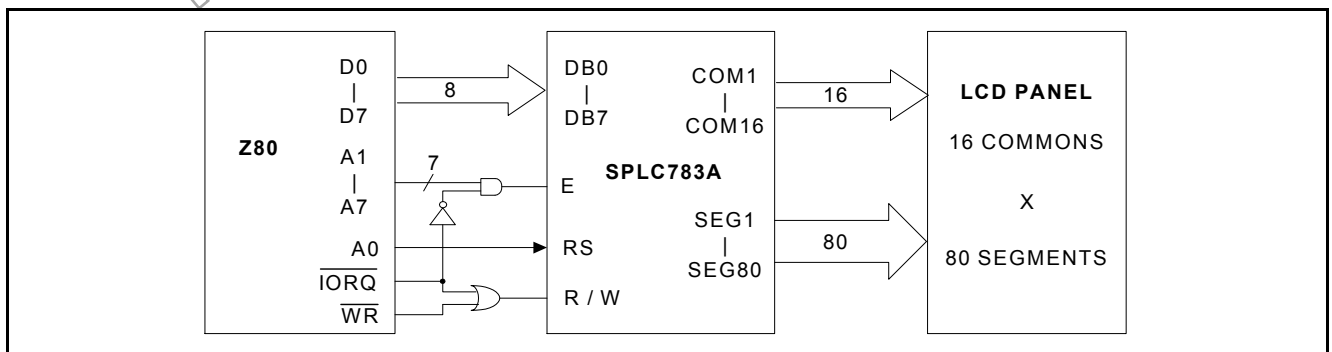
**7.2. Interface to MPU**
**7.2.1. Interface to 8-bit MPU (6805)**

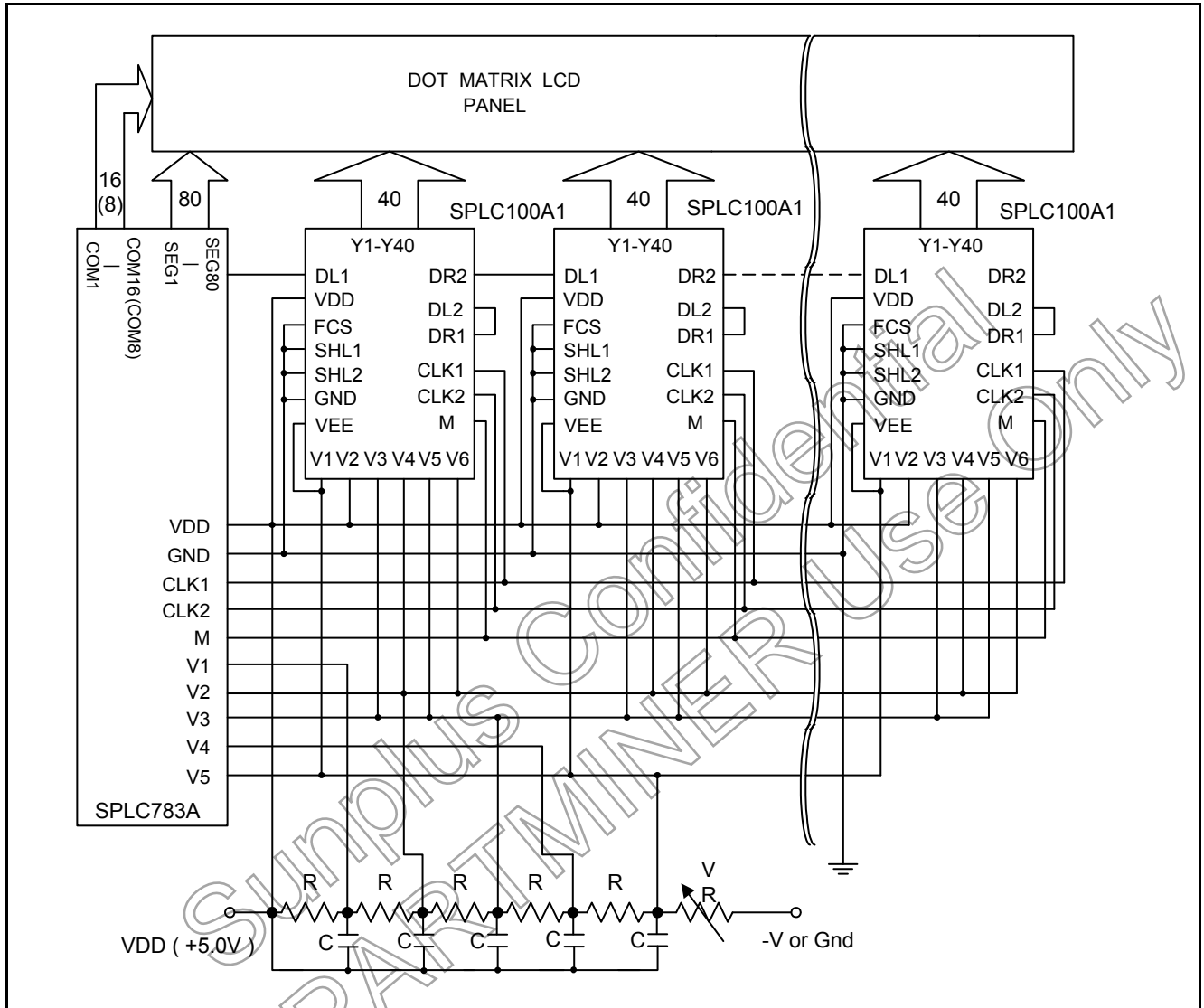
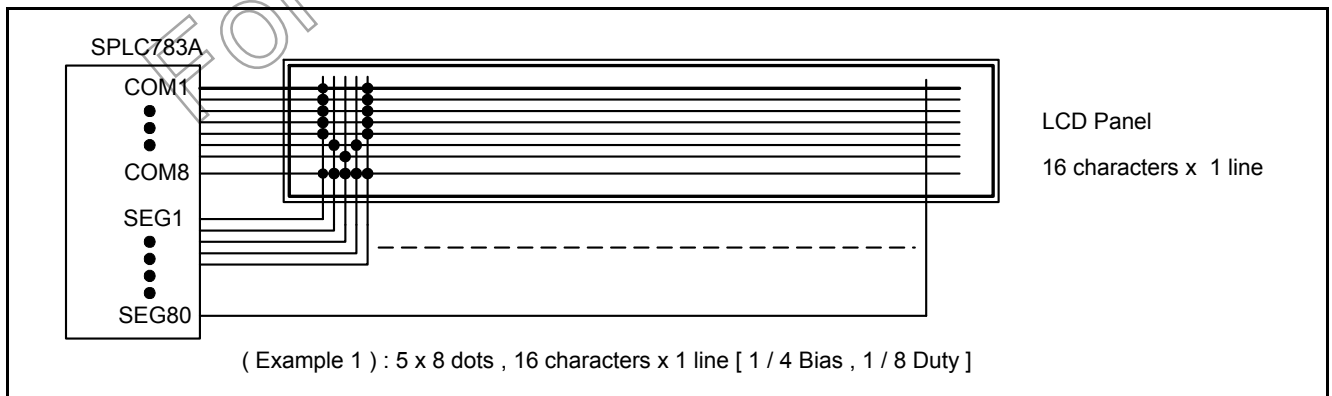
**7.2.2. Interface to 8-bit MPU (Z80)**

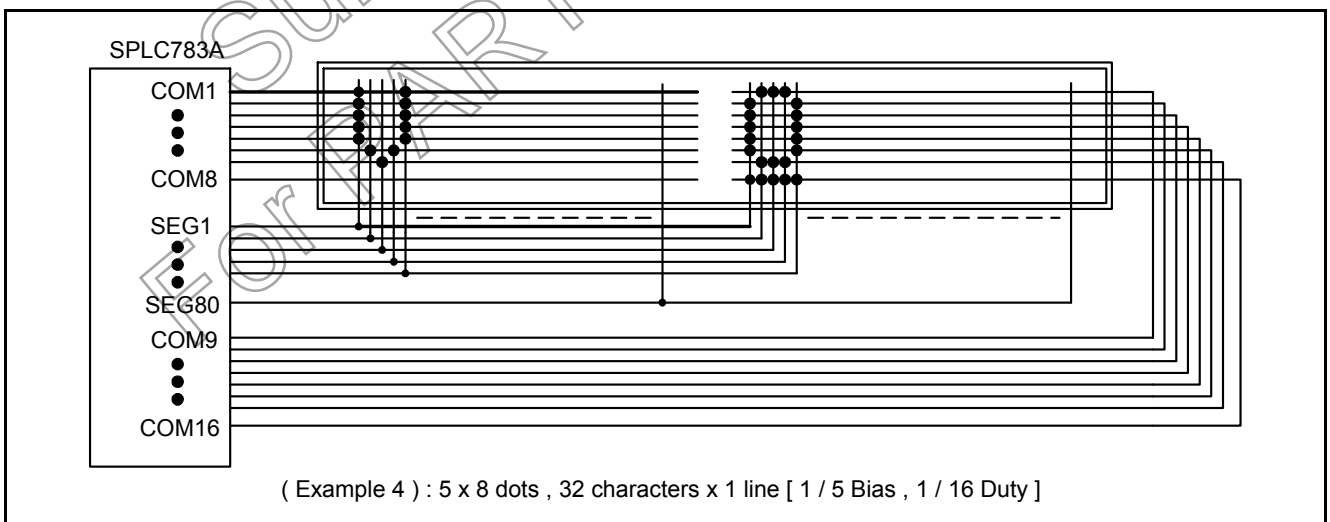
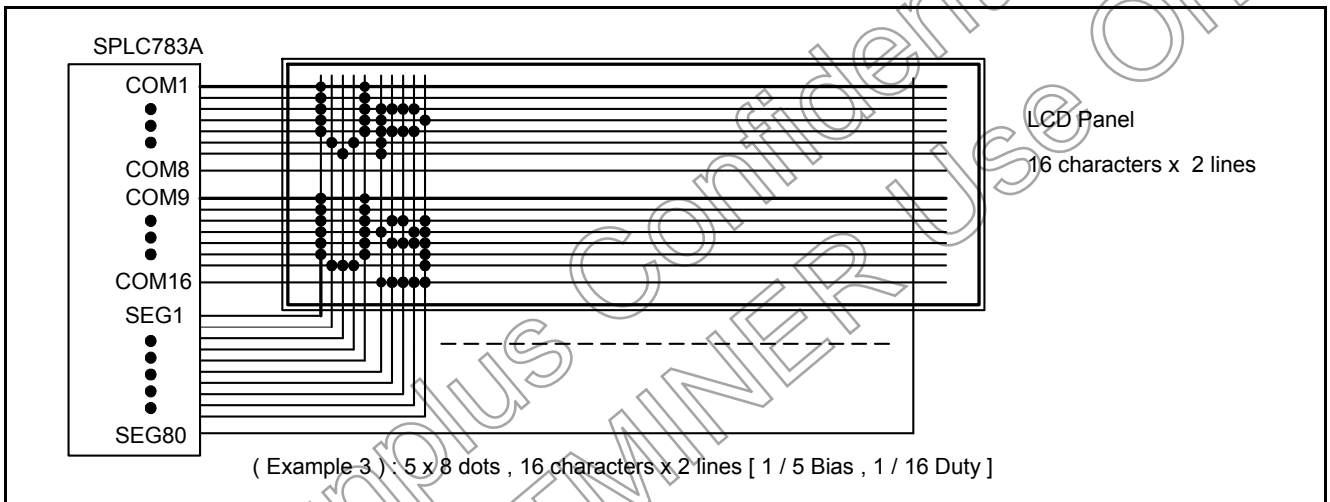
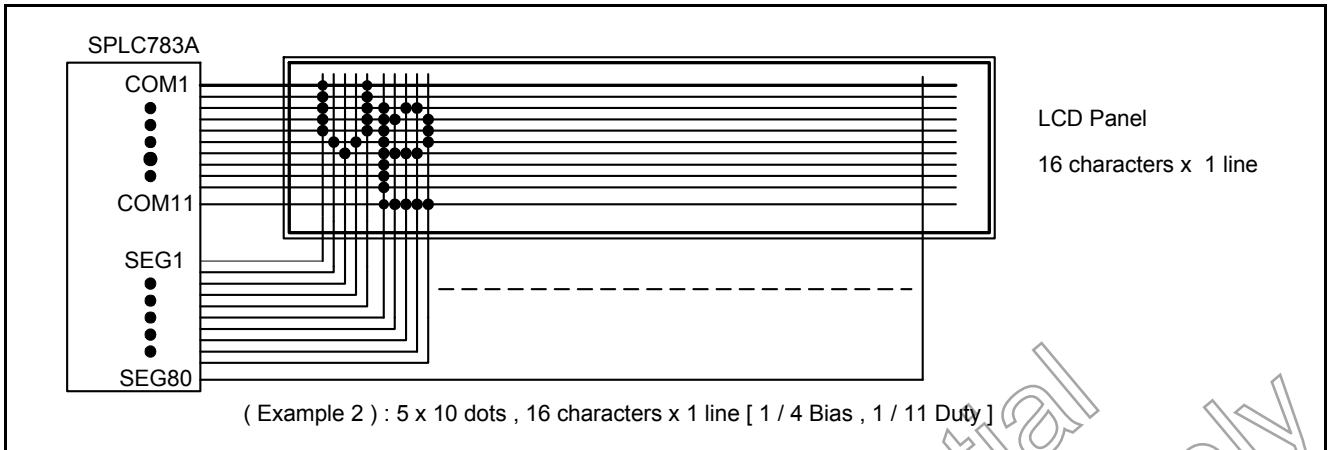
**7.3. SPLC783A Application Circuit**

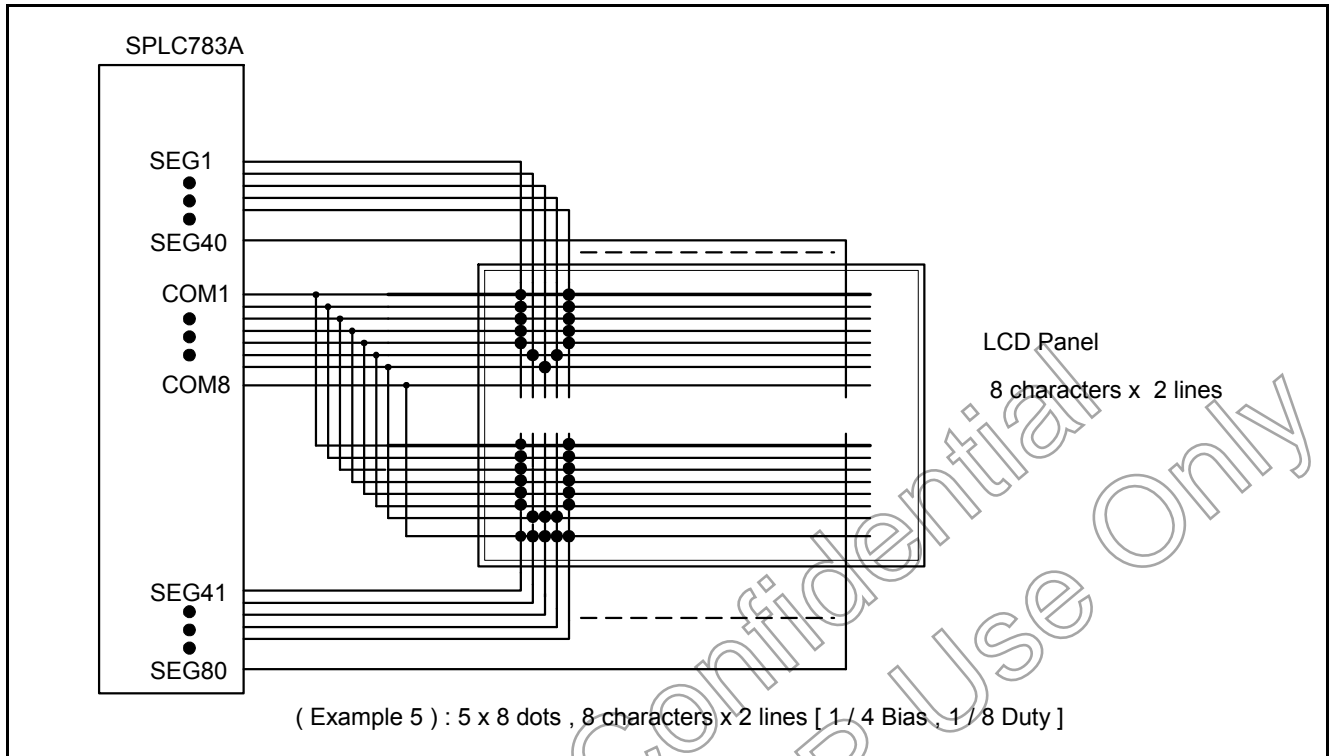
**7.4. Applications for LCD**





Sunplus Confidential  
For PARTMINER Use Only



**8. CHARACTER GENERATOR ROM**
**8.1. SPLC783A - 001**

Upper 4 bit Lower 4 bit	LLLL	LLLH	LLHL	LLHH	LHLL	LHLH	LHHL	LHHH	HLLL	HLLH	HLHL	HLHH	HHLL	HHLH	HHHL	HHHH
LLLL				0	1	2	3	4				一	夕	三	※	0
LLLH			!	1	0	3	4				。	ア	チ	ウ	音	0
LLHL			"	2	R	b	r				「	イ	ウ	※	0	0
LLHH			#	3	S	S	S				」	ウ	テ	モ	※	0
LHLL			*	4	D	T	d	t			、	工	ト	ホ	0	0
LHLH			%	5	E	U	e	u			・	オ	カ	工	0	0
LHHL			&	6	F	V	f	v			ヲ	カ	ニ	ヨ	0	0
LHHH			'	7	G	W	g	w			ヲ	キ	※	ウ	0	0
HLLL			0	8	H	X	h	x			、	ウ	※	ル	0	0
HLLH			>	9	I	V	i	v			ウ	ウ	ル	0	0	0
HLHL			*	*	J	Z	j	z			エ	コ	0	0	0	0
HLHH			+	*	K	K	<				オ	オ	0	0	0	0
HHLL			,	<	L	1	l	1			カ	0	0	0	0	0
HHLH			-	=	M	M	>				ユ	※	0	0	0	0
HHHL			.	>	N	n	*				ヨ	0	0	0	0	0
HHHH			/	?	O	o	*				ウ	ウ	0	0	0	0

**8.2. SPLC783A - 003**

Upper 4 bit Lower 4 bit	LLLL	LLLH	LLHL	LLHH	LHLL	LHLH	LHHL	LHHH	HLLL	HLLH	HLHL	HLHH	HHLL	HHLH	HHHL	HHHH
LLLL	0	1	2	3	4	5	6	7	8	9	A	B	C	D	E	F
LLLH	G	H	I	J	K	L	M	N	O	P	Q	R	S	T	U	V
LLHL	W	X	Y	Z	[	\	]	^	_	`	a	b	c	d	e	f
LLHH	g	h	i	j	k	l	m	n	o	p	q	r	s	t	u	v
LHLL	w	x	y	z	{		}	~								
LHLH																
LHHL																
LHHH																
HLLL																
HLLH																
HLHL																
HLHH																
HHLL																
HHLH																
HHHL																
HHHH																

**9. PACKAGE/PAD LOCATIONS**
**9.1. PAD Assignment and Locations**

Please contact Sunplus sales representatives for more information.

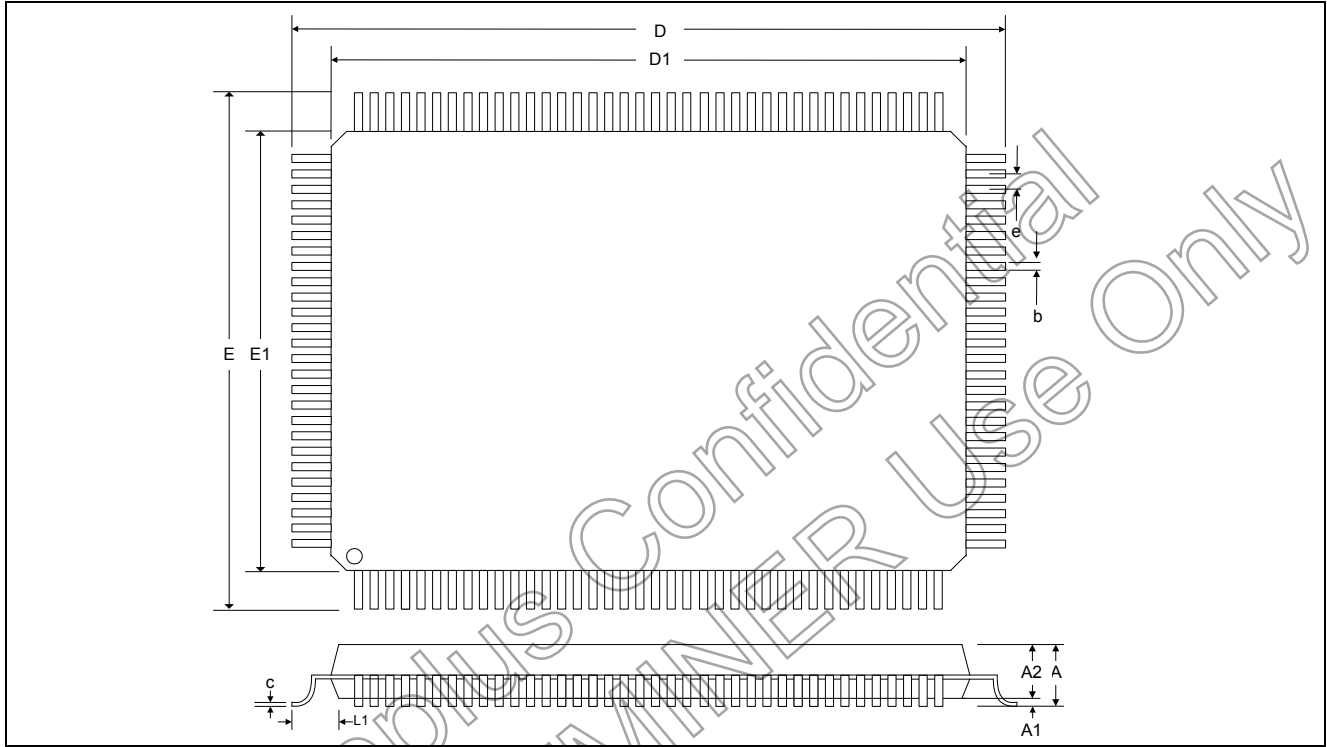
**9.2. Package Information**

Symbol	Min.	Nom.	Max.
A		-	1.60
A1	0.05	-	0.15
A2	1.35	1.40	1.45
D	21.90	22.00	22.10
D1	19.90	20.00	20.10
E	15.90	16.00	16.10
E1	13.90	14.00	14.10
e	0.50 BSC.		
b	0.17	0.22	0.27
c	0.09	-	0.20
L1	1.00 REF		

Unit: Millimeter

**9.3. Ordering Information**

Product Number	Package Type
SPLC783A-NnnV-C	Chip form
SPLC783A-NnnV-PL11	Package form - LQFP 128*
SPLC783A-NnnV-HL11	Green Package form - LQFP 128**

**Note1:** Code number is assigned for customer.

**Note2:** Code number (N = A - Z or 0 - 9, nn = 00 - 99); version (V = A - Z).

**9.4. Storage Condition and Period for Package**

Package	Moisture sensitivity level	Max. Reflow temperature	Floor life storage condition	Dry pack
*LQFP	LEVEL 3	220 +5/-0°C	168Hrs @ $\leq 30^\circ\text{C}$ / 60% R.H.	Yes
**LQFP	LEVEL 3	255 +5/-0°C	168Hrs @ $\leq 30^\circ\text{C}$ / 60% R.H.	Yes

**Note1:** Please refer to IPC/JEDEC standard J-STD-020A and EIA JEDEC stand JFSD22-A112

**Note2:** or refer to the "CAUTION Note" on dry pack bag.

**9.5. Recommended SMT Temperature Profile**

This "Recommended" temperature profile is a rough guideline for SMT process reference. Most of SUNPLUS leadframe base product choice Matte Tin and Sn/Bi for plating recipe. For

PPF(Pre-Plated Frame) product with 63/37 solder paste, we recommend 240°C~245°C for peak temperature.

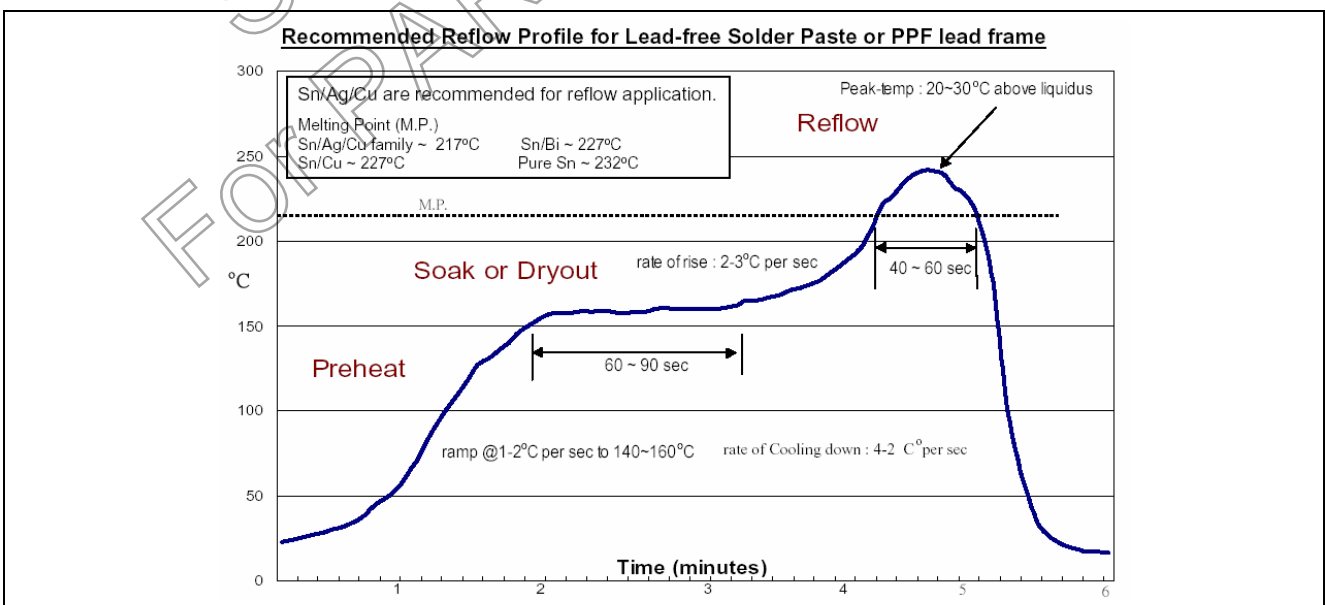
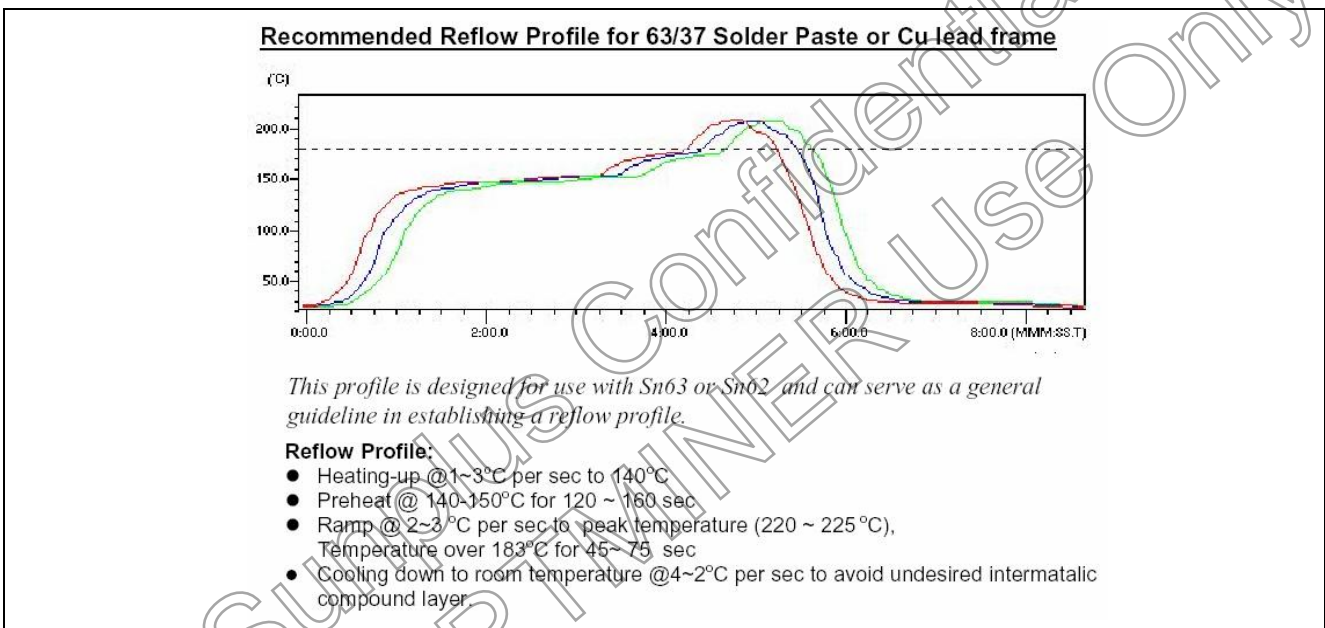

**10. DISCLAIMER**

The information appearing in this publication is believed to be accurate.

Integrated circuits sold by Sunplus Technology are covered by the warranty and patent indemnification provisions stipulated in the terms of sale only. SUNPLUS makes no warranty, express, statutory implied or by description regarding the information in this publication or regarding the freedom of the described chip(s) from patent infringement. FURTHER, SUNPLUS MAKES NO WARRANTY OF MERCHANTABILITY OR FITNESS FOR ANY PURPOSE. SUNPLUS reserves the right to halt production or alter the specifications and prices at any time without notice. Accordingly, the reader is cautioned to verify that the data sheets and other information in this publication are current before placing orders. Products described herein are intended for use in normal commercial applications. Applications involving unusual environmental or reliability requirements, e.g. military equipment or medical life support equipment, are specifically not recommended without additional processing by SUNPLUS for such applications. Please note that application circuits illustrated in this document are for reference purposes only.

Sunplus Confidential  
For PARTMINER Use Only

**11. REVISION HISTORY**

Date	Revision #	Description	Page
MAR. 10, 2005	1.4	1. Modify 8.1 and 8.2 code numbers from 2 digits to 3 digits 2. Add Green Package Product Number 3. Add sections 9.4 and 9.5 4. Correct pin name: from RW to R/W	33, 34 35 36 5, 9 19, 20
APR. 01, 2004	1.3	1. Add min. and max. value in Instruction Table 2. Add 8-bit/4-bit data transfer timing sequence example	9 19 - 20
NOV. 25, 2003	1.2	1. Add package information: LQFP 128 pin 2. Remove " <u>9. PACKAGE/PAD LOCATIONS</u> "	5, 6, 34
SEP. 27, 2002	1.1	Correct " <u>9. PACKAGE/PAD LOCATIONS</u> "	31 - 33
OCT. 02, 2001	1.0	Original	

Sunplus Confidential  
 For PARTMINER Use Only