

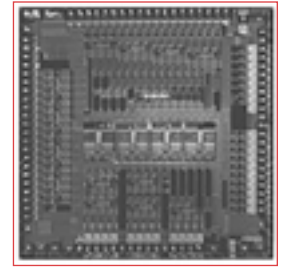

# BCM3360 PRODUCT Brief



## QAMLINK® ADVANCED PHY CABLE MODEM

### BCM3360 FEATURES

- **Advanced single-chip cable modem supporting DOCSIS/EuroDOCSIS 1.0/1.1 and complete FA-TDMA Advanced Physical Layer feature set**
- **The BCM3360 integrates:**
  - Advanced QAMLink® transceiver supporting Annex A/B/C operation
  - DOCSIS/EuroDOCSIS 1.0/1.1 MAC
  - High-performance, 140-MHz MIPS-32 CPU
  - Advanced QAMLink®, downstream demodulator, supporting 4/16/32/64/128/256/512/1024 QAM
  - Advanced QAMLink®, upstream modulator, supporting FA-TDMA Advanced PHY with 2/4/8/16/ 32/64/128/256 QAM
  - Upstream power amplifier
  - IPSEC Engine for VPN gateway applications
  - 10/100 Ethernet MAC/PHY with MII interface
  - USB 1.1 slave port with integrated transceiver
  - Single 28-MHz reference crystal
  - Extended device interface
- **Advanced RF and control interface to BCM3415 CMOS Tuner for DOCSIS/EuroDOCSIS solutions**
- **On-chip support for PROPANE™ packet acceleration**
- **1.8/3.3 volt operation**
- **356-pin PBGA package**

### SUMMARY OF BENEFITS

- **First complete Advanced PHY, single-chip cable modem.**
- **Advanced QAMLink® modulator/demodulator provides higher throughputs and superior performance in noisy plant environments.**
- **DOCSIS/EuroDOCSIS 1.0/1.1 MAC is compatible with existing Cable Modem application code, resulting in minimum time to market.**
- **Integrated 10/100 Ethernet MAC/PHY and USB 1.1 with integrated transceiver provides lowest cost CPE interface.**
- **Integrated HPNA 2.0 core provides fast home networking over existed telephone wiring.**
- **EBI interface supports connection to wireless home networking module.**
- **On-chip PROPANE™ supports DOCSIS/EuroDOCSIS based packet acceleration.**
- **EJTAG embedded ICE support is compatible with existing MIPS32 development tools, improving software development and testing.**

Advanced PHY DOCSIS/EuroDOCSIS 1.0/1.1 Cable Modem Home Gateway

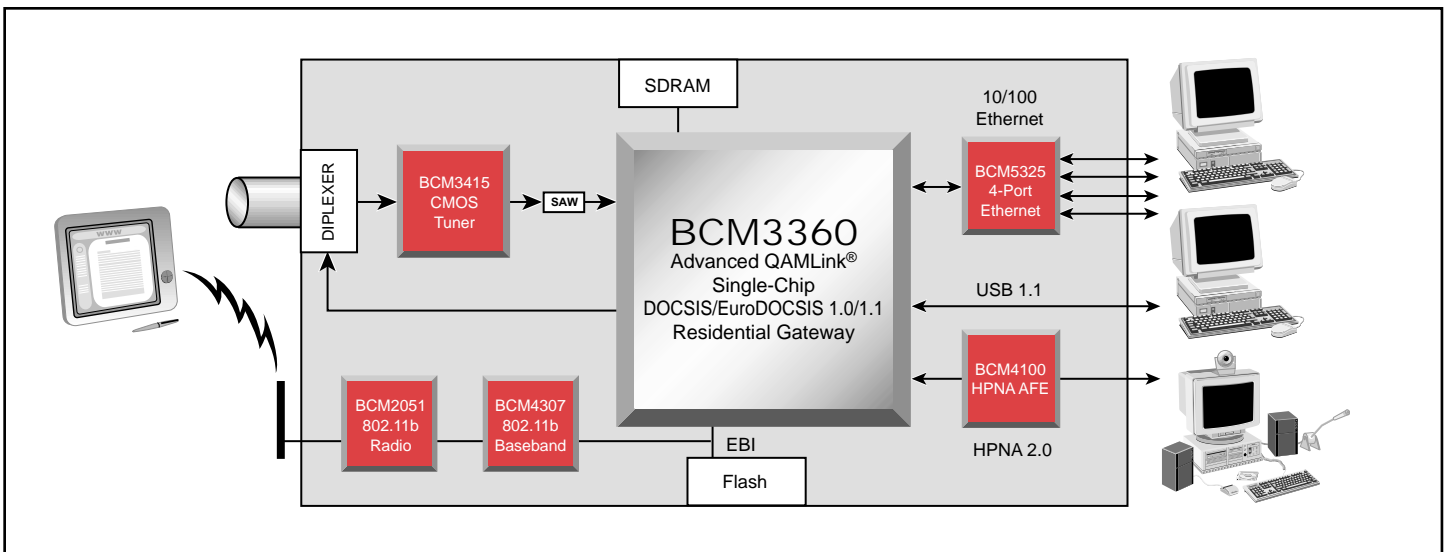

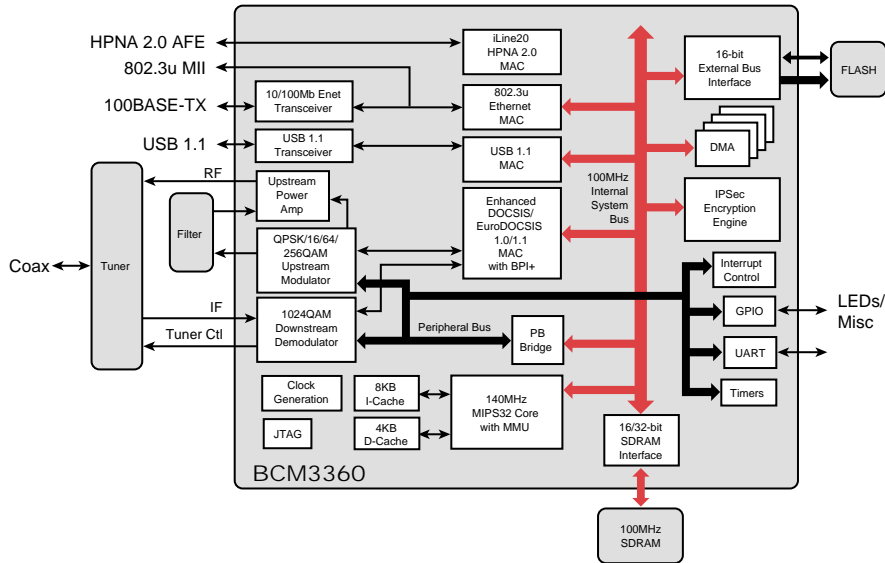

The **BCM3360** combines an Advanced PHY QAM receiver, an Advanced PHY QAM transmitter, a DOCSIS/EuroDOCSIS 1.0/1.1 Media Access Controller (MAC) with complete interleaver support for Advanced PHY, a 140-MHz MIPS32 Processor, an IP Security (IPSec) engine, a 16-bit, 100-MHz SDRAM Interface, 10/100 Ethernet MAC with integrated transceiver and MII Interface, a USB 1.1 controller with integrated transceiver, an HPNA 2.0 MAC and support for extended devices through an EBI interface.

The QAM receiver directly samples a tuner output with a 10-bit A/D converter and input ACG amplifier. The receiver digitally resamples and demodulates the signal with recovered clock and carrier timing, filters and equalizes the data, and passes soft decisions to an ITU-T J.83 Annex A/B/C compatible decoder. A 40-tap adaptive decision feedback equalizer is implemented. The receiver supports variable symbol rate 64/256 QAM FEC decoding. The final received data stream is delivered in a serial MPEG-2 transport format. All gain, clock, and carrier, acquisition and tracking loops are integrated in the QAM receiver.

The upstream transmitter takes burst or continuous data, provides FEC encoding and pre-equalization for DOCSIS/EuroDOCSIS applications, filters and applies QPSK or QAM16 modulation to the data stream, amplifies the signal through the integrated upstream power amplifier, and provides a direct 0–65 MHz analog output.

**Broadcom**<sup>®</sup>, the pulse logo<sup>®</sup>, **QAMLink**<sup>®</sup>, **PROPANE**<sup>™</sup> and **Connecting Everything**<sup>™</sup> are trademarks of Broadcom Corporation and/or its subsidiaries in the United States and certain other countries. All other trademarks are the property of their respective owners.

Connecting  
**everything**<sup>™</sup>

BROADCOM CORPORATION  
16215 Alton Parkway, P.O. Box 57013  
Irvine, California 92619-7013

© 2002 by BROADCOM CORPORATION. All rights reserved.  
3360-PB03-R-4.24.02

The **BCM3360** Media Access Controller (MAC) includes all features required for full DOCSIS/EuroDOCSIS 1.0/1.1 compliance, including full support for baseline privacy (BPI+) encryption and decryption. Multiple user support includes 16 SIDS in downstream, 16 DA perfect match filters, a 256 entry CAM for multicast/unicast hash filter and 16 independent upstream queues for simultaneous support of QoS and BE traffic. To enhance operational support, the **BCM3360** MAC provides extended Network Management MIB/Diagnostic features, as well as immediate UCC (on the fly) using independent resets for downstream and upstream and both individual queue reset/flush for upstream queues. The **BCM3360** uses advanced Propane techniques to provide packet acceleration to significantly improve upstream channel utilization.

The **BCM3360** is the first single-chip cable modem that supports the FA-TDMA Advanced PHY technology. In addition, the **BCM3360** supports advanced QAM rates for higher performance and at the same time offers better performance in noisy plants. With on-chip HPNA support, combined with the EBI support for wireless CPE interface, the BCM3360 provides the ideal platform for a home gateway cable modem.

**Ordering Information:**

**BCM3360** KPB DOCSIS/EuroDOCSIS applications



Phone: 949-450-8700  
FAX: 949-450-8710  
Email: info@broadcom.com  
Web: www.broadcom.com