

## Micro MINI E0C6008

### 4-bit Single Chip Microcomputer



- E0C6200C Core CPU
- Built-in LCD Driver
- Serial Interface

#### ■ DESCRIPTION

Micro MINI "E0C6008" is a single chip microcomputer for battery-driven products with 7-segment LCD display. It achieves low cost performance, and is suitable for a product added some feature instead of standard IC. It consists that Seiko Epson's original core CPU E0C6200C, LCD driver (48 segments × 4 commons), 832 words RAM, 4K words ROM, serial interface, clock timer and so on.

#### ■ FEATURES

- CMOS LSI 4-bit parallel processing
- Main clock ..... 32.768kHz
- Sub clock ..... 500kHz (Typ. CR/Ceramic)
- Instruction set ..... 108 instructions
- ROM capacity ..... 4,096 × 12 bits
- RAM capacity ..... 832 × 4 bits
- I/O port ..... I: 9 bits  
O: 8 bits  
I/O: 8 bits
- Battery low detection circuit (BLD) ..... 1.2V (E0C60L08)  
2.4V (E0C6008)  
2.4V (E0C60A08)
- Clock timer ..... 1ch.
- Stopwatch timer ..... 1ch.
- Watchdog timer ..... Built-in
- Serial interface ..... Synchronous 8 bits
- LCD driver ..... 48 segments × 4/3/2 commons
- Operation voltage ..... 0.9 to 1.7V (E0C60L08)  
1.8 to 3.5V (E0C6008)  
2.2 to 3.5V (E0C60A08)
- Power consumption ..... 1.0μA (32.768kHz X'tal, 3.0V, HALT)  
2.2μA (32.768kHz X'tal, 3.0V, RUN)  
50μA (500kHz Ceramic, 3.0V, RUN)
- Package ..... Die form, QFP15-100pin or QFP5-100pin

# E0C6008

## ■ BLOCK DIAGRAM

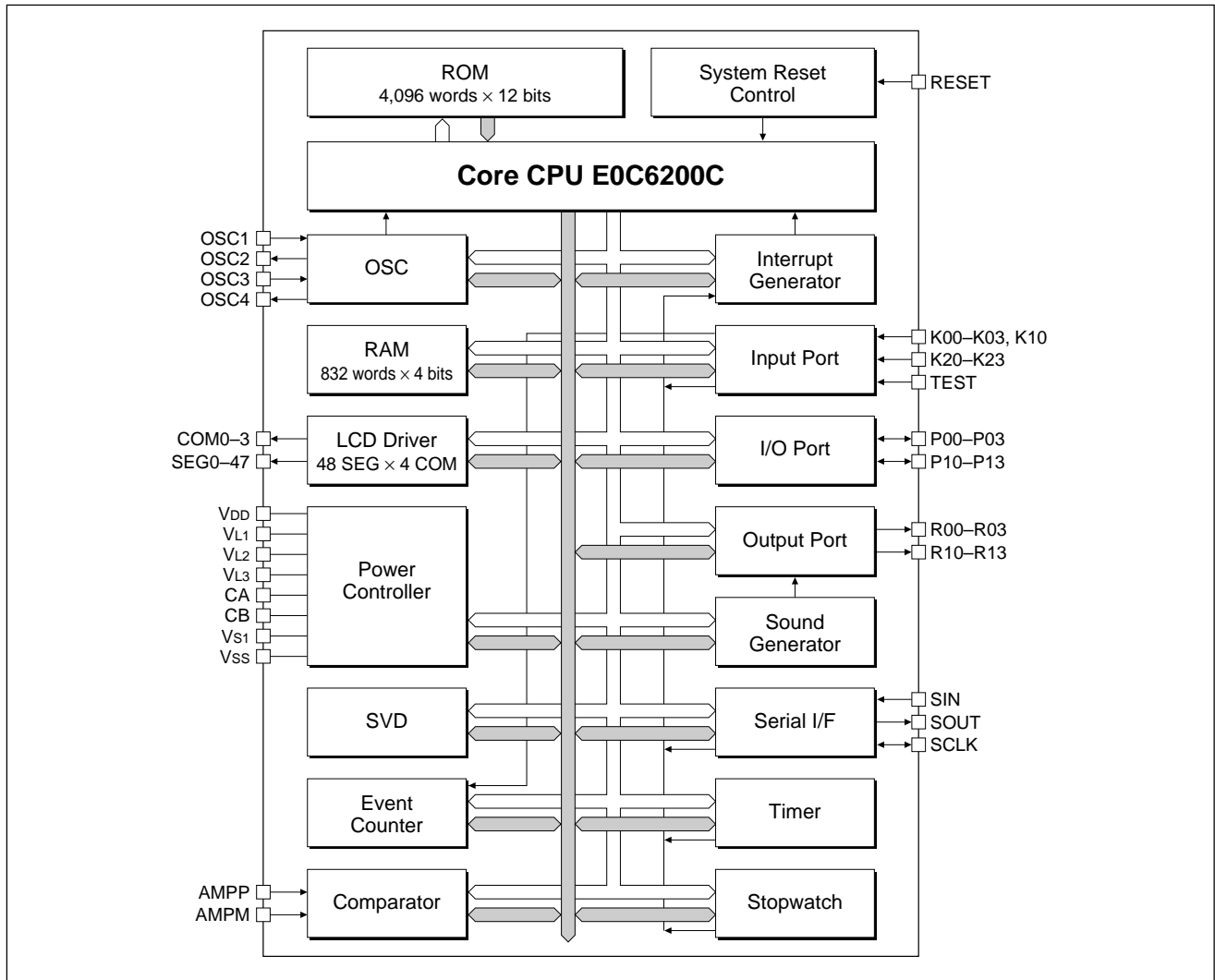

## ■ PIN CONFIGURATION

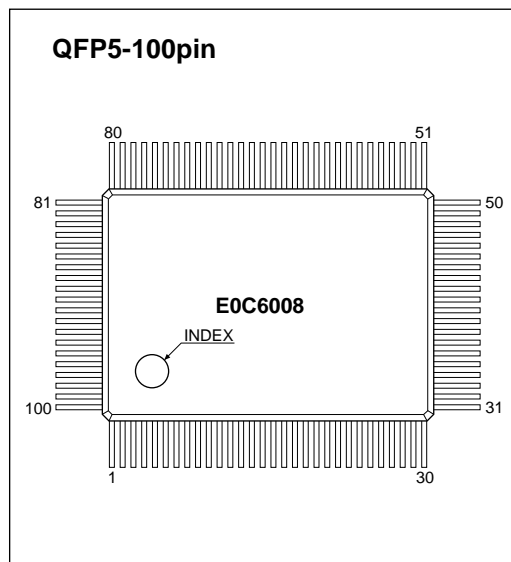

No.	Pin name	No.	Pin name	No.	Pin name	No.	Pin name	No.	Pin name
1	COM1	21	SEG29	41	SEG10	61	K01	81	R12
2	COM0	22	SEG28	42	SEG9	62	K00	82	R11
3	SEG47	23	SEG27	43	SEG8	63	SIN	83	R10
4	SEG46	24	SEG26	44	SEG7	64	SOUT	84	R13
5	SEG45	25	SEG25	45	SEG6	65	N.C.	85	Vss
6	SEG44	26	SEG24	46	SEG5	66	SCLK	86	RESET
7	SEG43	27	TEST	47	SEG4	67	P03	87	OSC4
8	SEG42	28	SEG23	48	SEG3	68	P02	88	OSC3
9	SEG41	29	SEG22	49	SEG2	69	P01	89	Vs1
10	SEG40	30	SEG21	50	SEG1	70	P00	90	OSC2
11	SEG39	31	SEG20	51	SEG0	71	N.C.	91	OSC1
12	SEG38	32	SEG19	52	AMPP	72	N.C.	92	VDD
13	SEG37	33	SEG18	53	AMPM	73	P13	93	VL3
14	SEG36	34	SEG17	54	K23	74	P12	94	VL2
15	SEG35	35	SEG16	55	K22	75	P11	95	VL1
16	SEG34	36	SEG15	56	K21	76	P10	96	CA
17	SEG33	37	SEG14	57	K20	77	R03	97	CB
18	SEG32	38	SEG13	58	K10	78	R02	98	N.C.
19	SEG31	39	SEG12	59	K03	79	R01	99	COM3
20	SEG30	40	SEG11	60	K02	80	R00	100	COM2

N.C. = No Connection

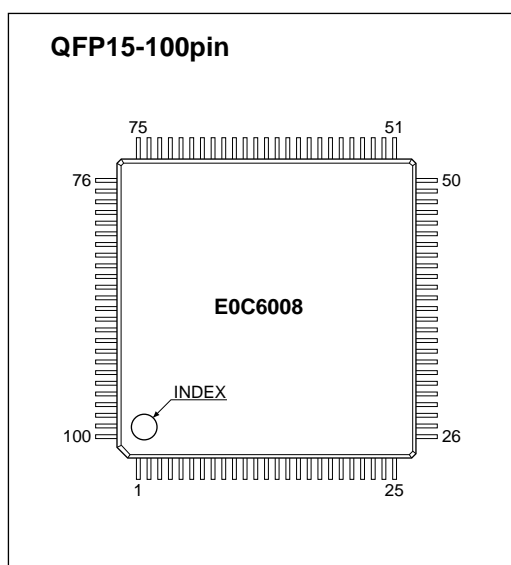

No.	Pin name	No.	Pin name	No.	Pin name	No.	Pin name	No.	Pin name
1	SEG47	21	SEG27	41	SEG9	61	K00	81	R10
2	SEG46	22	SEG26	42	SEG8	62	SIN	82	R13
3	SEG45	23	SEG25	43	SEG7	63	SOUT	83	Vss
4	SEG44	24	SEG24	44	SEG6	64	N.C.	84	RESET
5	SEG43	25	TEST	45	SEG5	65	SCLK	85	OSC4
6	SEG42	26	SEG23	46	SEG4	66	N.C.	86	OSC3
7	SEG41	27	SEG22	47	SEG3	67	P03	87	Vs1
8	SEG40	28	SEG21	48	SEG2	68	P02	88	OSC2
9	SEG39	29	SEG20	49	SEG1	69	P01	89	OSC1
10	SEG38	30	SEG19	50	SEG0	70	P00	90	VDD
11	SEG37	31	SEG18	51	AMPP	71	P13	91	VL3
12	SEG36	32	SEG17	52	AMPM	72	P12	92	VL2
13	SEG35	33	SEG16	53	K23	73	P11	93	VL1
14	SEG34	34	SEG15	54	K22	74	P10	94	CA
15	SEG33	35	SEG14	55	K21	75	R03	95	CB
16	SEG32	36	SEG13	56	K20	76	R02	96	N.C.
17	SEG31	37	SEG12	57	K10	77	R01	97	COM3
18	SEG30	38	N.C.	58	K03	78	R00	98	COM2
19	SEG29	39	SEG11	59	K02	79	R12	99	COM1
20	SEG28	40	SEG10	60	K01	80	R11	100	COM0

N.C. = No Connection

## PIN DESCRIPTION

Pin name	Pin No.		I/O	Function
	QFP5-100	QFP15-100		
VDD	92	90	(I)	Power supply pin (+)
Vss	85	83	(I)	Power supply pin (-)
Vs1	89	87	-	Oscillation and internal logic system voltage output pin
VL1	95	93	-	LCD drive voltage output pin (approx. -1.05 V or 1/2·VL2)
VL2	94	92	-	LCD drive voltage output pin (2·VL1 or approx. -2.10 V)
VL3	93	91	-	LCD drive voltage output pin (3·VL1 or 3/2·VL2)
CA, CB	96, 97	94, 95	-	Boost capacitor connecting pin
OSC1	91	89	I	Crystal oscillation input pin
OSC2	90	88	O	Crystal oscillation output pin
OSC3	88	86	I	CR or ceramic oscillation input pin * (N.C. for E0C6008 and E0C60L08)
OSC4	87	85	O	CR or ceramic oscillation output pin * (N.C. for E0C6008 and E0C60L08)
K00-K03	62-59	61-58	I	Input port pin
K10	58	57	I	Input port pin
K20-K23	57-54	56-53	I	Input port pin
P00-P03	70-67	70-67	I/O	I/O port pin
P10-P13	76-73	74-71	I/O	I/O port pin
R00-R03	80-77	78-75	O	Output port pin
R10	83	81	O	Output port pin or BZ output pin *
R13	84	82	O	Output port pin or $\overline{\text{BZ}}$ output pin *
R11	82	80	O	Output port pin or SIOF output pin *
R12	81	79	O	Output port pin or FOUT output pin *
SIN	63	62	I	Serial interface data input pin
SOUT	64	63	O	Serial interface data output pin
SCLK	66	65	I/O	Serial interface clock input/output pin
AMPP	52	51	I	Analog comparator non-inverted input pin
AMPM	53	52	I	Analog comparator inverted input pin
SEG0-47	51-28, 26-3	50-39, 37-26, 24-1	O	LCD segment output pin or DC output pin *
COM0-3	2, 1, 100, 99	100-97	O	LCD common output pin (1/2, 1/3 or 1/4 duty are selectable *)
RESET	86	84	I	Initial reset input pin
TEST	27	25	I	Input pin for test

\* Can be selected by mask option

# EOC6008

## ■ BASIC EXTERNAL CONNECTION DIAGRAM

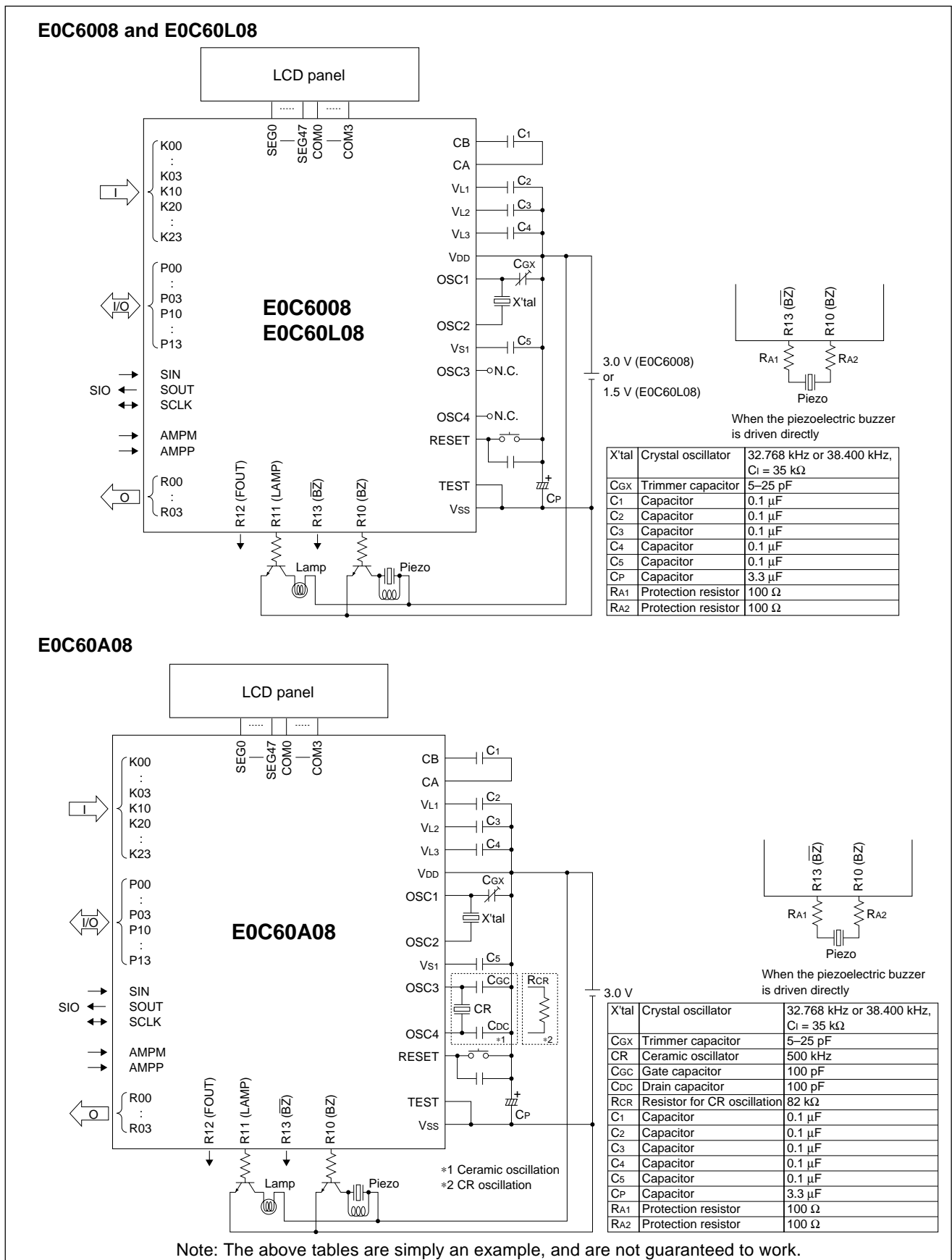

## ■ ELECTRICAL CHARACTERISTICS

### ● Absolute Maximum Ratings

#### E0C6008 and E0C60A08

(V<sub>DD</sub>=0V)

Rating	Symbol	Value	Unit
Supply voltage	V <sub>SS</sub>	-5.0 to 0.5	V
Input voltage (1)	V <sub>I</sub>	V <sub>SS</sub> -0.3 to 0.5	V
Input voltage (2)	V <sub>I</sub> OSC	V <sub>S1</sub> -0.3 to 0.5	V
Permissible total output current *1	ΣI <sub>VSS</sub>	10	mA
Operating temperature	T <sub>OPR</sub>	-20 to 70	°C
Storage temperature	T <sub>STG</sub>	-65 to 150	°C
Soldering temperature / time	T <sub>SOL</sub>	260°C, 10sec (lead section)	—
Permissible dissipation *2	P <sub>D</sub>	250	mW

\*1: The permissible total output current is the sum total of the current (average current) that simultaneously flows from the output pins (or is drawn in).

\*2: In case of plastic package.

#### E0C60L08

(V<sub>DD</sub>=0V)

Rating	Symbol	Value	Unit
Supply voltage	V <sub>SS</sub>	-2.0 to 0.5	V
Input voltage (1)	V <sub>I</sub>	V <sub>SS</sub> -0.3 to 0.5	V
Input voltage (2)	V <sub>I</sub> OSC	V <sub>S1</sub> -0.3 to 0.5	V
Permissible total output current *1	ΣI <sub>VSS</sub>	10	mA
Operating temperature	T <sub>OPR</sub>	-20 to 70	°C
Storage temperature	T <sub>STG</sub>	-65 to 150	°C
Soldering temperature / time	T <sub>SOL</sub>	260°C, 10sec (lead section)	—
Permissible dissipation *2	P <sub>D</sub>	250	mW

\*1: The permissible total output current is the sum total of the current (average current) that simultaneously flows from the output pins (or is drawn in).

\*2: In case of plastic package.

### ● Recommended Operating Conditions

#### E0C6008

(T<sub>a</sub>=-20 to 70°C)

Condition	Symbol	Remark	Min.	Typ.	Max.	Unit
Supply voltage	V <sub>SS</sub>	V <sub>DD</sub> =0V	-3.5	-3.0	-1.8	V
Oscillation frequency	f <sub>OSC1</sub>	Either one is selected	—	32.768	—	kHz
			—	38.400	—	

#### E0C60L08

(T<sub>a</sub>=-20 to 70°C)

Condition	Symbol	Remark	Min.	Typ.	Max.	Unit
Supply voltage	V <sub>SS</sub>	V <sub>DD</sub> =0V	-1.7	-1.5	-1.1	V
		V <sub>DD</sub> =0V, with software control *1	-1.7	-1.5	-0.9 *2	V
		V <sub>DD</sub> =0V, when analog comparator is used	-1.7	-1.5	-1.2	V
Oscillation frequency	f <sub>OSC1</sub>	Either one is selected	—	32.768	—	kHz
			—	38.400	—	

\*1: When switching to heavy load protection mode.

\*2: The possibility of LCD panel display differs depending on the characteristics of the LCD panel.

#### E0C60A08

(T<sub>a</sub>=-20 to 70°C)

Condition	Symbol	Remark	Min.	Typ.	Max.	Unit
Supply voltage	V <sub>SS</sub>	V <sub>DD</sub> =0V	-3.5	-3.0	-2.2	V
Oscillation frequency (1)	f <sub>OSC1</sub>	Either one is selected	—	32.768	—	kHz
			—	38.400	—	
Oscillation frequency (2)	f <sub>OSC3</sub>	duty 50±5%	50	500	600	kHz

# E0C6008

## ● DC Characteristics

### E0C6008 and E0C60A08

(Unless otherwise specified:  $V_{DD}=0V$ ,  $V_{SS}=-3.0V$ ,  $f_{osc1}=32.768kHz$ ,  $T_a=25^{\circ}C$ ,  $V_{S1}/V_{L1}-V_{L3}$  are internal voltage,  $C_1-C_5=0.1\mu F$ )

Characteristic	Symbol	Condition	Min.	Typ.	Max.	Unit
High level input voltage (1)	$V_{IH1}$	K00-03, K10, K20-23, P00-03 P10-13, SIN	$0.2 \cdot V_{SS}$		0	V
High level input voltage (2)	$V_{IH2}$	SCLK, RESET, TEST	$0.1 \cdot V_{SS}$		0	V
Low level input voltage (1)	$V_{IL1}$	K00-03, K10, K20-23, P00-03 P10-13, SIN	$V_{SS}$		$0.8 \cdot V_{SS}$	V
Low level input voltage (2)	$V_{IL2}$	SCLK, RESET, TEST	$V_{SS}$		$0.9 \cdot V_{SS}$	V
High level input current (1)	$I_{IH1}$	$V_{IH1}=0V$ No pull-down	0		0.5	$\mu A$
High level input current (2)	$I_{IH2}$	$V_{IH2}=0V$ With pull-down	4		16	$\mu A$
High level input current (3)	$I_{IH3}$	$V_{IH3}=0V$ With pull-down	25		100	$\mu A$
Low level input current	$I_{IL}$	$V_{IL}=V_{SS}$	-0.5		0	$\mu A$
High level output current (1)	$I_{OH1}$	$V_{OH1}=0.1 \cdot V_{SS}$			-1.8	mA
High level output current (2)	$I_{OH2}$	$V_{OH2}=0.1 \cdot V_{SS}$			-0.9	mA
Low level output current (1)	$I_{OL1}$	$V_{OL1}=0.9 \cdot V_{SS}$	6.0			mA
Low level output current (2)	$I_{OL2}$	$V_{OL2}=0.9 \cdot V_{SS}$	3.0			mA
Common output current	$I_{OH3}$	$V_{OH3}=-0.05V$			-3	$\mu A$
	$I_{OL3}$	$V_{OL3}=V_{L3}+0.05V$	3			$\mu A$
Segment output current (during LCD output)	$I_{OH4}$	$V_{OH4}=-0.05V$			-3	$\mu A$
	$I_{OL4}$	$V_{OL4}=V_{L3}+0.05V$	3			$\mu A$
Segment output current (during DC output)	$I_{OH5}$	$V_{OH5}=0.1 \cdot V_{SS}$			-200	$\mu A$
	$I_{OL5}$	$V_{OL5}=0.9 \cdot V_{SS}$	200			$\mu A$

### E0C60L08

(Unless otherwise specified:  $V_{DD}=0V$ ,  $V_{SS}=-1.5V$ ,  $f_{osc1}=32.768kHz$ ,  $T_a=25^{\circ}C$ ,  $V_{S1}/V_{L1}-V_{L3}$  are internal voltage,  $C_1-C_5=0.1\mu F$ )

Characteristic	Symbol	Condition	Min.	Typ.	Max.	Unit
High level input voltage (1)	$V_{IH1}$	K00-03, K10, K20-23, P00-03 P10-13, SIN	$0.2 \cdot V_{SS}$		0	V
High level input voltage (2)	$V_{IH2}$	SCLK, RESET, TEST	$0.1 \cdot V_{SS}$		0	V
Low level input voltage (1)	$V_{IL1}$	K00-03, K10, K20-23, P00-03 P10-13, SIN	$V_{SS}$		$0.8 \cdot V_{SS}$	V
Low level input voltage (2)	$V_{IL2}$	SCLK, RESET, TEST	$V_{SS}$		$0.9 \cdot V_{SS}$	V
High level input current (1)	$I_{IH1}$	$V_{IH1}=0V$ No pull-down	0		0.5	$\mu A$
High level input current (2)	$I_{IH2}$	$V_{IH2}=0V$ With pull-down	2		10	$\mu A$
High level input current (3)	$I_{IH3}$	$V_{IH3}=0V$ With pull-down	12		60	$\mu A$
Low level input current	$I_{IL}$	$V_{IL}=V_{SS}$	-0.5		0	$\mu A$
High level output current (1)	$I_{OH1}$	$V_{OH1}=0.1 \cdot V_{SS}$			-300	$\mu A$
High level output current (2)	$I_{OH2}$	$V_{OH2}=0.1 \cdot V_{SS}$			-150	$\mu A$
Low level output current (1)	$I_{OL1}$	$V_{OL1}=0.9 \cdot V_{SS}$	1400			$\mu A$
Low level output current (2)	$I_{OL2}$	$V_{OL2}=0.9 \cdot V_{SS}$	700			$\mu A$
Common output current	$I_{OH3}$	$V_{OH3}=-0.05V$			-3	$\mu A$
	$I_{OL3}$	$V_{OL3}=V_{L3}+0.05V$	3			$\mu A$
Segment output current (during LCD output)	$I_{OH4}$	$V_{OH4}=-0.05V$			-3	$\mu A$
	$I_{OL4}$	$V_{OL4}=V_{L3}+0.05V$	3			$\mu A$
Segment output current (during DC output)	$I_{OH5}$	$V_{OH5}=0.1 \cdot V_{SS}$			-100	$\mu A$
	$I_{OL5}$	$V_{OL5}=0.9 \cdot V_{SS}$	100			$\mu A$

## ● Analog Circuit Characteristics and Current Consumption

### E0C6008 (Normal Operating Mode)

(Unless otherwise specified:  $V_{DD}=0V$ ,  $V_{SS}=-3.0V$ ,  $f_{osc1}=32.768kHz$ ,  $T_a=25^{\circ}C$ ,  $C_G=25pF$ ,  $V_{S1}/V_{L1}-V_{L3}$  are internal voltage,  $C_1-C_5=0.1\mu F$ )

Characteristic	Symbol	Condition	Min.	Typ.	Max.	Unit
LCD drive voltage	$V_{L1}$	Connect 1 M $\Omega$ load resistor between $V_{DD}$ and $V_{L1}$ (without panel load)	1/2· $V_{L2}$ - 0.1		1/2· $V_{L2}$ $\times 0.9$	V
	$V_{L2}$	Connect 1 M $\Omega$ load resistor between $V_{DD}$ and $V_{L2}$ (without panel load)	-2.30	-2.10	-1.90	V
	$V_{L3}$	Connect 1 M $\Omega$ load resistor between $V_{DD}$ and $V_{L3}$ (without panel load)	3/2· $V_{L2}$ - 0.1		3/2· $V_{L2}$ $\times 0.9$	V
BLD voltage *1	$V_{B0}$	BLC="0"	-2.35	-2.20	-2.05	V
	$V_{B1}$	BLC="1"	-2.40	-2.25	-2.10	V
	$V_{B2}$	BLC="2"	-2.45	-2.30	-2.15	V
	$V_{B3}$	BLC="3"	-2.50	-2.35	-2.20	V
	$V_{B4}$	BLC="4"	-2.55	-2.40	-2.25	V
	$V_{B5}$	BLC="5"	-2.60	-2.45	-2.30	V
	$V_{B6}$	BLC="6"	-2.65	-2.50	-2.35	V
	$V_{B7}$	BLC="7"	-2.70	-2.55	-2.40	V
BLD circuit response time	$t_B$				100	$\mu$ sec
Sub-BLD voltage	$V_{BS}$		-2.55	-2.40	-2.25	V
Sub-BLD circuit response time	$t_{BS}$				100	$\mu$ sec
Analog comparator input voltage	$V_{IP}$	Non-inverted input (AMPP)	$V_{SS}+0.3$		$V_{DD}-0.9$	V
	$V_{IM}$	Inverted input (AMPM)				
Analog comparator offset voltage	$V_{OF}$				10	mV
Analog comparator response time	$t_{AMP}$	$V_{IP}=-1.5V$ $V_{IM}=V_{IP}\pm 15mV$			3	msec
Current consumption	IOP	During HALT	Without panel load	1.0	2.0	$\mu$ A
		During operation *2		2.2	4.0	$\mu$ A

\*1: The relationships among  $V_{B0}-V_{B7}$  are  $V_{B0}>V_{B1}>V_{B2}>...>V_{B5}>V_{B6}>V_{B7}$ .

\*2: The BLD circuit, sub-BLD circuit and analog comparator are in the OFF status.

### E0C6008 (Heavy Load Protection Mode)

(Unless otherwise specified:  $V_{DD}=0V$ ,  $V_{SS}=-3.0V$ ,  $f_{osc1}=32.768kHz$ ,  $T_a=25^{\circ}C$ ,  $C_G=25pF$ ,  $V_{S1}/V_{L1}-V_{L3}$  are internal voltage,  $C_1-C_5=0.1\mu F$ )

Characteristic	Symbol	Condition	Min.	Typ.	Max.	Unit
LCD drive voltage	$V_{L1}$	Connect 1 M $\Omega$ load resistor between $V_{DD}$ and $V_{L1}$ (without panel load)	1/2· $V_{L2}$ - 0.1		1/2· $V_{L2}$ $\times 0.9$	V
	$V_{L2}$	Connect 1 M $\Omega$ load resistor between $V_{DD}$ and $V_{L2}$ (without panel load)	-2.30	-2.10	-1.90	V
	$V_{L3}$	Connect 1 M $\Omega$ load resistor between $V_{DD}$ and $V_{L3}$ (without panel load)	3/2· $V_{L2}$ - 0.1		3/2· $V_{L2}$ $\times 0.9$	V
BLD voltage *1	$V_{B0}$	BLC="0"	-2.35	-2.20	-2.05	V
	$V_{B1}$	BLC="1"	-2.40	-2.25	-2.10	V
	$V_{B2}$	BLC="2"	-2.45	-2.30	-2.15	V
	$V_{B3}$	BLC="3"	-2.50	-2.35	-2.20	V
	$V_{B4}$	BLC="4"	-2.55	-2.40	-2.25	V
	$V_{B5}$	BLC="5"	-2.60	-2.45	-2.30	V
	$V_{B6}$	BLC="6"	-2.65	-2.50	-2.35	V
	$V_{B7}$	BLC="7"	-2.70	-2.55	-2.40	V
BLD circuit response time	$t_B$				100	$\mu$ sec
Sub-BLD voltage	$V_{BS}$		-2.55	-2.40	-2.25	V
Sub-BLD circuit response time	$t_{BS}$				100	$\mu$ sec
Analog comparator input voltage	$V_{IP}$	Non-inverted input (AMPP)	$V_{SS}+0.3$		$V_{DD}-0.9$	V
	$V_{IM}$	Inverted input (AMPM)				
Analog comparator offset voltage	$V_{OF}$				10	mV
Analog comparator response time	$t_{AMP}$	$V_{IP}=-1.5V$ $V_{IM}=V_{IP}\pm 15mV$			3	msec
Current consumption	IOP	During HALT	Without panel load	10	20	$\mu$ A
		During operation *2		12	25	$\mu$ A

\*1: The relationships among  $V_{B0}-V_{B7}$  are  $V_{B0}>V_{B1}>V_{B2}>...>V_{B5}>V_{B6}>V_{B7}$ .

\*2: The BLD circuit and sub-BLD circuit are in the ON status (HLMOD="1", BLS="0").

The analog comparator is in the OFF status.

# E0C6008

## E0C60L08 (Normal Operating Mode)

(Unless otherwise specified:  $V_{DD}=0V$ ,  $V_{SS}=-1.5V$ ,  $f_{osc1}=32.768kHz$ ,  $T_a=25^{\circ}C$ ,  $C_G=25pF$ ,  $V_{S1}/V_{L1}-V_{L3}$  are internal voltage,  $C_1-C_5=0.1\mu F$ )

Characteristic	Symbol	Condition	Min.	Typ.	Max.	Unit
LCD drive voltage	VL1	Connect 1 MΩ load resistor between VDD and VL1 (without panel load)	-1.15	-1.05	-0.95	V
	VL2	Connect 1 MΩ load resistor between VDD and VL2 (without panel load)	2·VL1 - 0.1		2·VL1 ×0.9	V
	VL3	Connect 1 MΩ load resistor between VDD and VL3 (without panel load)	3·VL1 - 0.1		3·VL1 ×0.9	V
BLD voltage *1	VB0	BLC="0"	-1.15	-1.05	-0.95	V
	VB1	BLC="1"	-1.20	-1.10	-1.00	V
	VB2	BLC="2"	-1.25	-1.15	-1.05	V
	VB3	BLC="3"	-1.30	-1.20	-1.10	V
	VB4	BLC="4"	-1.35	-1.25	-1.15	V
	VB5	BLC="5"	-1.40	-1.30	-1.20	V
	VB6	BLC="6"	-1.45	-1.35	-1.25	V
BLD circuit response time	t <sub>B</sub>				100	μsec
Sub-BLD voltage	V <sub>BS</sub>		-1.30	-1.20	-1.10	V
Sub-BLD circuit response time	t <sub>BS</sub>				100	μsec
Analog comparator input voltage	V <sub>IP</sub>	Non-inverted input (AMPP)	V <sub>SS</sub> +0.3		V <sub>DD</sub> -0.9	V
	V <sub>IM</sub>	Inverted input (AMPM)				
Analog comparator offset voltage	V <sub>OF</sub>				20	mV
Analog comparator response time	t <sub>AMP</sub>	V <sub>IP</sub> =-1.1V V <sub>IM</sub> =V <sub>IP</sub> ±30mV			3	msec
Current consumption	I <sub>OP</sub>	During HALT		1.0	2.0	μA
		During operation *2	Without panel load	2.2	4.0	μA

\*1: The relationships among V<sub>B0</sub>-V<sub>B7</sub> are V<sub>B0</sub>>V<sub>B1</sub>>V<sub>B2</sub>>...>V<sub>B5</sub>>V<sub>B6</sub>>V<sub>B7</sub>.

\*2: The BLD circuit, sub-BLD circuit and analog comparator are in the OFF status.

## E0C60L08 (Heavy Load Protection Mode)

(Unless otherwise specified:  $V_{DD}=0V$ ,  $V_{SS}=-1.5V$ ,  $f_{osc1}=32.768kHz$ ,  $T_a=25^{\circ}C$ ,  $C_G=25pF$ ,  $V_{S1}/V_{L1}-V_{L3}$  are internal voltage,  $C_1-C_5=0.1\mu F$ )

Characteristic	Symbol	Condition	Min.	Typ.	Max.	Unit
LCD drive voltage	VL1	Connect 1 MΩ load resistor between VDD and VL1 (without panel load)	-1.15	-1.05	-0.95	V
	VL2	Connect 1 MΩ load resistor between VDD and VL2 (without panel load)	2·VL1 - 0.1		2·VL1 ×0.85	V
	VL3	Connect 1 MΩ load resistor between VDD and VL3 (without panel load)	3·VL1 - 0.1		3·VL1 ×0.85	V
BLD voltage *1	VB0	BLC="0"	-1.15	-1.05	-0.95	V
	VB1	BLC="1"	-1.20	-1.10	-1.00	V
	VB2	BLC="2"	-1.25	-1.15	-1.05	V
	VB3	BLC="3"	-1.30	-1.20	-1.10	V
	VB4	BLC="4"	-1.35	-1.25	-1.15	V
	VB5	BLC="5"	-1.40	-1.30	-1.20	V
	VB6	BLC="6"	-1.45	-1.35	-1.25	V
BLD circuit response time	t <sub>B</sub>				100	μsec
Sub-BLD voltage	V <sub>BS</sub>		-1.30	-1.20	-1.10	V
Sub-BLD circuit response time	t <sub>BS</sub>				100	μsec
Analog comparator input voltage	V <sub>IP</sub>	Non-inverted input (AMPP)	V <sub>SS</sub> +0.3		V <sub>DD</sub> -0.9	V
	V <sub>IM</sub>	Inverted input (AMPM)				
Analog comparator offset voltage	V <sub>OF</sub>				20	mV
Analog comparator response time	t <sub>AMP</sub>	V <sub>IP</sub> =-1.1V V <sub>IM</sub> =V <sub>IP</sub> ±30mV			3	msec
Current consumption	I <sub>OP</sub>	During HALT		6.5	10	μA
		During operation *2	Without panel load	8.5	15	μA

\*1: The relationships among V<sub>B0</sub>-V<sub>B7</sub> are V<sub>B0</sub>>V<sub>B1</sub>>V<sub>B2</sub>>...>V<sub>B5</sub>>V<sub>B6</sub>>V<sub>B7</sub>.

\*2: The BLD circuit and sub-BLD circuit are in the ON status (HLMOD="1", BLS="0").

The analog comparator is in the OFF status.



## E0C60A08 (Normal Operating Mode)

(Unless otherwise specified:  $V_{DD}=0V$ ,  $V_{SS}=-3.0V$ ,  $f_{osc1}=32.768kHz$ ,  $T_a=25^{\circ}C$ ,  $C_G=25pF$ ,  $V_{S1}/V_{L1}-V_{L3}$  are internal voltage,  $C_1-C_5=0.1\mu F$ )

Characteristic	Symbol	Condition	Min.	Typ.	Max.	Unit
LCD drive voltage	VL1	Connect 1 MΩ load resistor between VDD and VL1 (without panel load)	-1.15	-1.05	-0.95	V
	VL2	Connect 1 MΩ load resistor between VDD and VL2 (without panel load)	2·VL1 - 0.1		2·VL1 ×0.9	V
	VL3	Connect 1 MΩ load resistor between VDD and VL3 (without panel load)	3·VL1 - 0.1		3·VL1 ×0.9	V
BLD voltage *1	VB0	BLC="0"	-2.35	-2.20	-2.05	V
	VB1	BLC="1"	-2.40	-2.25	-2.10	V
	VB2	BLC="2"	-2.45	-2.30	-2.15	V
	VB3	BLC="3"	-2.50	-2.35	-2.20	V
	VB4	BLC="4"	-2.55	-2.40	-2.25	V
	VB5	BLC="5"	-2.60	-2.45	-2.30	V
	VB6	BLC="6"	-2.65	-2.50	-2.35	V
BLD circuit response time	tB				100	μsec
Sub-BLD voltage	VBS		-2.55	-2.40	-2.25	V
Sub-BLD circuit response time	tBS				100	μsec
Analog comparator input voltage	VIP	Non-inverted input (AMPP)	VSS+0.3		VDD-0.9	V
	VIM	Inverted input (AMPM)				
Analog comparator offset voltage	VOF				10	mV
Analog comparator response time	tAMP	VIP=-1.5V VIM=VIP±15mV			3	msec
Current consumption	IOP	During HALT		1.1	2.0	μA
		During operation *2	Without panel load	3.0	5.0	μA
		During operation at 500kHz *2		50	70	μA

\*1: The relationships among VB0-VB7 are VB0>VB1>VB2>...VB5>VB6>VB7.

\*2: The BLD circuit, sub-BLD circuit and analog comparator are in the OFF status.

## E0C60A08 (Heavy Load Protection Mode)

(Unless otherwise specified:  $V_{DD}=0V$ ,  $V_{SS}=-3.0V$ ,  $f_{osc1}=32.768kHz$ ,  $T_a=25^{\circ}C$ ,  $C_G=25pF$ ,  $V_{S1}/V_{L1}-V_{L3}$  are internal voltage,  $C_1-C_5=0.1\mu F$ )

Characteristic	Symbol	Condition	Min.	Typ.	Max.	Unit
LCD drive voltage	VL1	Connect 1 MΩ load resistor between VDD and VL1 (without panel load)	-1.15	-1.05	-0.95	V
	VL2	Connect 1 MΩ load resistor between VDD and VL2 (without panel load)	2·VL1 - 0.1		2·VL1 ×0.9	V
	VL3	Connect 1 MΩ load resistor between VDD and VL3 (without panel load)	3·VL1 - 0.1		3·VL1 ×0.9	V
BLD voltage *1	VB0	BLC="0"	-2.35	-2.20	-2.05	V
	VB1	BLC="1"	-2.40	-2.25	-2.10	V
	VB2	BLC="2"	-2.45	-2.30	-2.15	V
	VB3	BLC="3"	-2.50	-2.35	-2.20	V
	VB4	BLC="4"	-2.55	-2.40	-2.25	V
	VB5	BLC="5"	-2.60	-2.45	-2.30	V
	VB6	BLC="6"	-2.65	-2.50	-2.35	V
BLD circuit response time	tB				100	μsec
Sub-BLD voltage	VBS		-2.55	-2.40	-2.25	V
Sub-BLD circuit response time	tBS				100	μsec
Analog comparator input voltage	VIP	Non-inverted input (AMPP)	VSS+0.3		VDD-0.9	V
	VIM	Inverted input (AMPM)				
Analog comparator offset voltage	VOF				10	mV
Analog comparator response time	tAMP	VIP=-1.5V VIM=VIP±15mV			3	msec
Current consumption	IOP	During HALT	Without panel load	6.5	10	μA
		During operation *2		8.5	15	μA
		During operation at 500kHz *2		55	75	μA

\*1: The relationships among VB0-VB7 are VB0>VB1>VB2>...VB5>VB6>VB7.

\*2: The BLD circuit and sub-BLD circuit are in the ON status (HLMOD="1", BLS="0").  
The analog comparator is in the OFF status.

# E0C6008

## ● Oscillation Characteristics

Oscillation characteristics will vary according to different conditions (elements used, board pattern). Use the following characteristics as reference values.

### E0C6008 (OSC1 Crystal Oscillation)

(Unless otherwise specified:  $V_{DD}=0V$ ,  $V_{SS}=-3.0V$ , Crystal: C-002R ( $C_I=35k\Omega$ ),  $C_G=25pF$ ,  $C_D=$ built-in,  $T_a=25^\circ C$ )

Characteristic	Symbol	Condition	Min.	Typ.	Max.	Unit
Oscillation start voltage	$V_{sta}$	$t_{sta} \leq 5sec$ ( $V_{SS}$ )	-1.8			V
Oscillation stop voltage	$V_{stp}$	$t_{stp} \leq 10sec$ ( $V_{SS}$ )	-1.8			V
Built-in capacitance (drain)	$C_D$	Including the parasitic capacitance inside the chip		20		pF
Frequency/voltage deviation	$\Delta f/\Delta V$	$V_{SS}=-1.8$ to $-3.5V$			5	ppm
Frequency/IC deviation	$\Delta f/\Delta IC$		-10		10	ppm
Frequency adjustment range	$\Delta f/\Delta C_G$	$C_G=5$ to $25pF$	35	45		ppm
Harmonic oscillation start voltage	$V_{hho}$	( $V_{SS}$ )			-3.5	V
Permitted leak resistance	$R_{leak}$	Between OSC1 and $V_{DD}$	200			$M\Omega$

### E0C60L08 (OSC1 Crystal Oscillation)

(Unless otherwise specified:  $V_{DD}=0V$ ,  $V_{SS}=-1.5V$ , Crystal: C-002R ( $C_I=35k\Omega$ ),  $C_G=25pF$ ,  $C_D=$ built-in,  $T_a=25^\circ C$ )

Characteristic	Symbol	Condition	Min.	Typ.	Max.	Unit
Oscillation start voltage	$V_{sta}$	$t_{sta} \leq 5sec$ ( $V_{SS}$ )	-1.1			V
Oscillation stop voltage	$V_{stp}$	$t_{stp} \leq 10sec$ ( $V_{SS}$ )	-1.1 (-0.9)*1			V
Built-in capacitance (drain)	$C_D$	Including the parasitic capacitance inside the chip		20		pF
Frequency/voltage deviation	$\Delta f/\Delta V$	$V_{SS}=-1.1$ (-0.9)*1 to $-1.7V$			5	ppm
Frequency/IC deviation	$\Delta f/\Delta IC$		-10		10	ppm
Frequency adjustment range	$\Delta f/\Delta C_G$	$C_G=5$ to $25pF$	35	45		ppm
Harmonic oscillation start voltage	$V_{hho}$	( $V_{SS}$ )			-1.7	V
Permitted leak resistance	$R_{leak}$	Between OSC1 and $V_{DD}$	200			$M\Omega$

\*1: Parentheses indicate value for operation in heavy load protection mode.

### E0C60A08 (OSC1 Crystal Oscillation)

(Unless otherwise specified:  $V_{DD}=0V$ ,  $V_{SS}=-3.0V$ , Crystal: C-002R ( $C_I=35k\Omega$ ),  $C_G=25pF$ ,  $C_D=$ built-in,  $T_a=25^\circ C$ )

Characteristic	Symbol	Condition	Min.	Typ.	Max.	Unit
Oscillation start voltage	$V_{sta}$	$t_{sta} \leq 5sec$ ( $V_{SS}$ )	-2.2			V
Oscillation stop voltage	$V_{stp}$	$t_{stp} \leq 10sec$ ( $V_{SS}$ )	-2.2			V
Built-in capacitance (drain)	$C_D$	Including the parasitic capacitance inside the chip		20		pF
Frequency/voltage deviation	$\Delta f/\Delta V$	$V_{SS}=-2.2$ to $-3.5V$			5	ppm
Frequency/IC deviation	$\Delta f/\Delta IC$		-10		10	ppm
Frequency adjustment range	$\Delta f/\Delta C_G$	$C_G=5$ to $25pF$	35	45		ppm
Harmonic oscillation start voltage	$V_{hho}$	( $V_{SS}$ )			-3.5	V
Permitted leak resistance	$R_{leak}$	Between OSC1 and $V_{DD}$	200			$M\Omega$

### E0C60A08 (OSC3 CR Oscillation)

(Unless otherwise specified:  $V_{DD}=0V$ ,  $V_{SS}=-3.0V$ ,  $R_{CR}=82k\Omega$ ,  $T_a=25^\circ C$ )

Characteristic	Symbol	Condition	Min.	Typ.	Max.	Unit
Oscillation frequency dispersion	$f_{osc3}$		-30	480kHz	30	%
Oscillation start voltage	$V_{sta}$	( $V_{SS}$ )	-2.2			V
Oscillation start time	$t_{sta}$	$V_{SS}=-2.2$ to $-3.5V$			3	msec
Oscillation stop voltage	$V_{stp}$	( $V_{SS}$ )	-2.2			V

### E0C60A08 (OSC3 Ceramic Oscillation)

(Unless otherwise specified:  $V_{DD}=0V$ ,  $V_{SS}=-3.0V$ , Ceramic oscillator: 500kHz,  $C_{GC}=C_{DC}=100pF$ ,  $T_a=25^\circ C$ )

Characteristic	Symbol	Condition	Min.	Typ.	Max.	Unit
Oscillation start voltage	$V_{sta}$	( $V_{SS}$ )	-2.2			V
Oscillation start time	$t_{sta}$	$V_{SS}=-2.2$ to $-3.5V$			5	msec
Oscillation stop voltage	$V_{stp}$	( $V_{SS}$ )	-2.2			V

**NOTICE:**

No part of this material may be reproduced or duplicated in any form or by any means without the written permission of Seiko Epson. Seiko Epson reserves the right to make changes to this material without notice. Seiko Epson does not assume any liability of any kind arising out of any inaccuracies contained in this material or due to its application or use in any product or circuit and, further, there is no representation that this material is applicable to products requiring high level reliability, such as, medical products. Moreover, no license to any intellectual property rights is granted by implication or otherwise, and there is no representation or warranty that anything made in accordance with this material will be free from any patent or copyright infringement of a third party. This material or portions thereof may contain technology or the subject relating to strategic products under the control of the Foreign Exchange and Foreign Trade Control Law of Japan and may require an export license from the Ministry of International Trade and Industry or other approval from another government agency.

© Seiko Epson Corporation 1999 All right reserved.

---

**SEIKO EPSON CORPORATION**

**ELECTRONIC DEVICES MARKETING DIVISION**

**IC Marketing & Engineering Group**

**ED International Marketing Department I (Europe & U.S.A.)**

421-8, Hino, Hino-shi, Tokyo 191-8501, JAPAN  
Phone : 042-587-5812 FAX : 042-587-5564

**ED International Marketing Department II (Asia)**

421-8, Hino, Hino-shi, Tokyo 191-8501, JAPAN  
Phone : 042-587-5814 FAX : 042-587-5110

