

4-bit Single Chip Microcomputer



- Core CPU Architecture
- Dot Matrix LCD Driver
- Serial Interface
- Programmable SVD Circuit

■ DESCRIPTION

The E0C624C is a CMOS 4-bit single chip microcomputer with a Core CPU E0C6200 as main component, ROM, RAM, dot matrix LCD driver, serial interface, time base counter, programmable SVD circuit, and others. The E0C624C is most suitable for applications with equipment requiring dot matrix display functions.

■ FEATURES

- CMOS LSI 4-bit parallel processing
- Clock OSC1 crystal or CR oscillation circuit : 32.768kHz
OSC3 ceramic or CR oscillation circuit : 2MHz (Max.)
- Instruction set 108 instructions
- Instruction cycle time Execution at 32.768kHz : 153μsec, 214μsec, 366μsec
Execution at 2MHz : 2.5μsec, 3.5μsec, 6.0μsec
- ROM capacity 5,120 × 12 bits
- RAM capacity Data : 1,152 × 4 bits
Segment : 204 × 4 bits
- External memory capacity Read/write (RAM) : 64K × 4 bits (Max.)
Read only (ROM) : 128K × 4 bits (Max.)
- Input port 8 bits (pull-up resistors are available by mask option)
- Output port 20 bits (can be switched to external memory bus and buzzer output by software)
- I/O port 16 bits (can be switched to external memory bus, special outputs and serial I/O by software)
- Serial interface 8-bit clock synchronous type
- Dot matrix LCD driver 51 segments × 8 commons/16 commons
- Time base counter 3 systems
- Programmable timer 8-bit : 1 system, with event counter function
- Watchdog timer
- Programmable SVD circuit 4 values programmable (2.2V to 4.2V)
- Sound generator With digital envelope function, volume control function (8 levels)
- Interrupt External : Input interrupt : 2 systems
Internal : Clock timer interrupt : 3 systems
Serial interface interrupt : 3 systems
- Supply voltage 1.8V to 5.5V
- Current consumption HALT mode (32.768kHz/3.0V) : 2.5μA (Typ.)
OPERATING mode (2MHz/5.0V) : 1.0mA (Typ.)
- Package QFP8-144pin (plastic)
Die form

E0C624C

■ BLOCK DIAGRAM

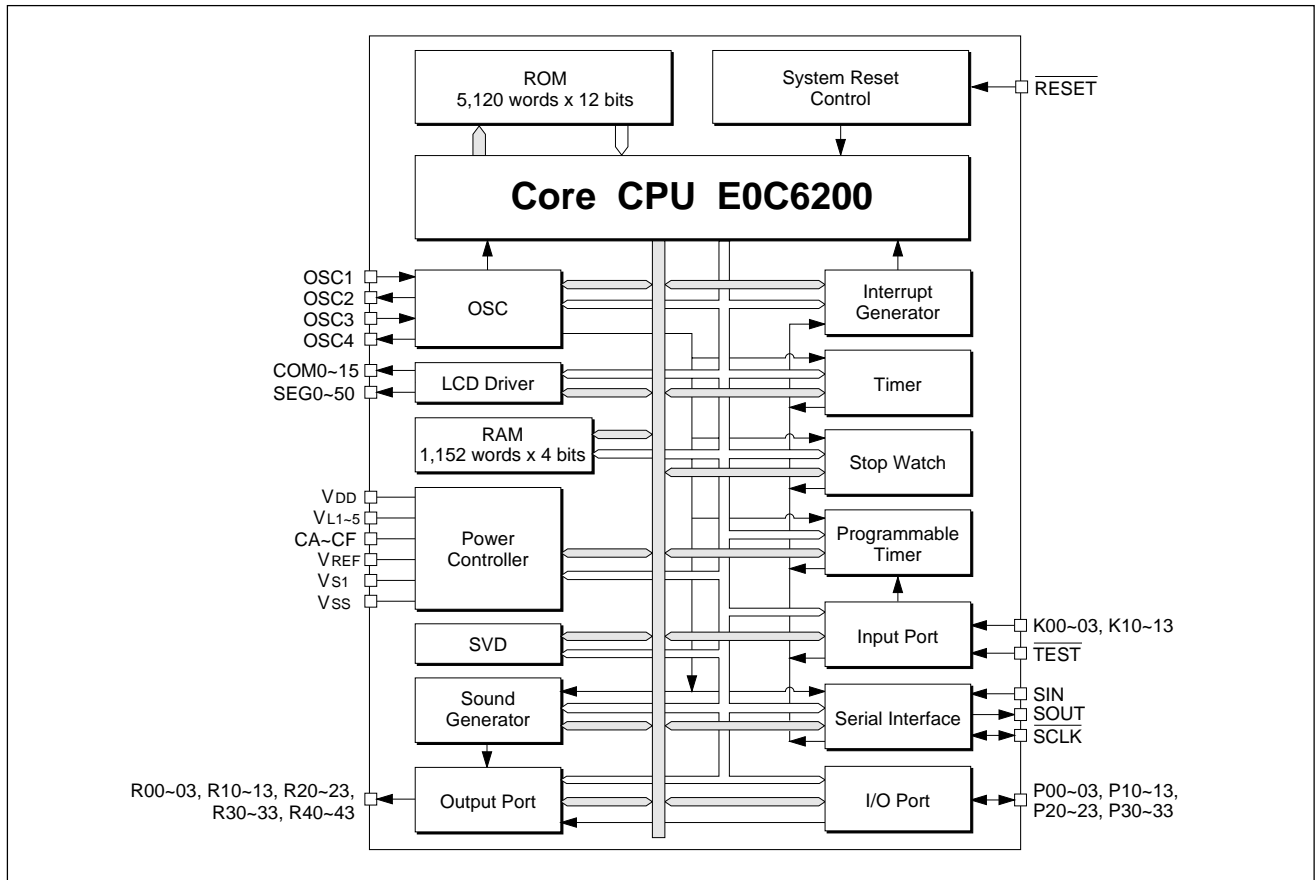

■ PIN CONFIGURATION

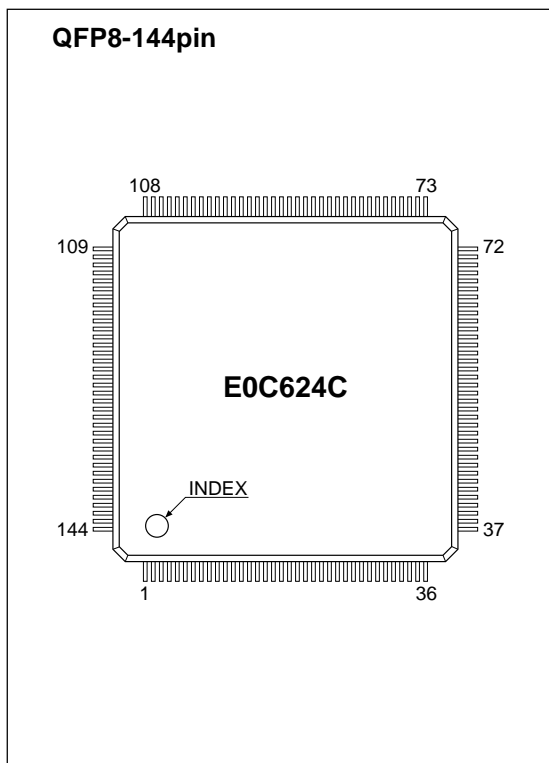

No.	Pin name	No.	Pin name	No.	Pin name	No.	Pin name	No.	Pin name
1	CB	30	SEG41	59	SEG15	88	P33	117	R13
2	CA	31	SEG40	60	SEG14	89	P32	118	R12
3	N.C.	32	SEG39	61	SEG13	90	P31	119	R11
4	COM0	33	SEG38	62	SEG12	91	P30	120	R10
5	COM1	34	SEG37	63	SEG11	92	P23	121	R03
6	COM2	35	N.C.	64	SEG10	93	P22	122	R02
7	COM3	36	N.C.	65	SEG9	94	P21	123	R01
8	COM4	37	SEG36	66	SEG8	95	P20	124	R00
9	COM5	38	SEG35	67	SEG7	96	P13	125	VSS
10	COM6	39	SEG34	68	SEG6	97	N.C.	126	RESET
11	COM7	40	SEG33	69	SEG5	98	P12	127	TEST
12	COM8	41	SEG32	70	SEG4	99	P11	128	OSC4
13	COM9	42	SEG31	71	SEG3	100	P10	129	OSC3
14	COM10	43	SEG30	72	SEG2	101	P03	130	VS1
15	COM11	44	SEG29	73	SEG1	102	P02	131	OSC2
16	COM12	45	SEG28	74	SEG0	103	P01	132	OSC1
17	COM13	46	SEG27	75	N.C.	104	P00	133	N.C.
18	COM14	47	SEG26	76	SCLK	105	R43	134	VDD
19	N.C.	48	SEG25	77	SOUT	106	R42	135	VREF
20	COM15	49	SEG24	78	SIN	107	R41	136	VL1
21	SEG50	50	N.C.	79	K13	108	R40	137	VL2
22	SEG49	51	SEG23	80	K12	109	R33	138	VL3
23	SEG48	52	SEG22	81	K11	110	R32	139	VL4
24	SEG47	53	SEG21	82	K10	111	R31	140	VL5
25	SEG46	54	SEG20	83	K03	112	R30	141	CF
26	SEG45	55	SEG19	84	N.C.	113	R23	142	CE
27	SEG44	56	SEG18	85	K02	114	R22	143	CD
28	SEG43	57	SEG17	86	K01	115	R21	144	CC
29	SEG42	58	SEG16	87	K00	116	R20		

N.C. = No Connection

PIN DESCRIPTION

Pin name	Pin No.	In/Out	Function
VDD	134	I	Power source (+) terminal
VSS	125	I	Power source (-) terminal
VS1	130	-	Oscillation and internal logic system regulated voltage
VL1-VL5	136-140	-	LCD system power (1/4 or 1/5 bias may be selected by mask option)
VREF	135	O	LCD system power test terminal
CA-CF	2, 1, 144-141	-	Booster capacitor connecting terminal
OSC1	132	I	Crystal or CR oscillation input terminal (selected by mask option)
OSC2	131	O	Crystal or CR oscillation output terminal (selected by mask option)
OSC3	129	I	Ceramic or CR oscillation input terminal (selected by mask option)
OSC4	128	O	Ceramic or CR oscillation output terminal (selected by mask option)
K00-K03, K10-K13	87-85, 83-79	I	Input terminal (Use of pull up resistor is selected by mask option)
P00-P03, P10-P13	104-98, 96	I/O	I/O terminal (Setting for data bus may be selected by mask option)
P20-P23	95-92	I/O	I/O terminal (CS output may be selected by mask option)
P30-P33	91-88	I/O	I/O terminal
R00-R03, R10-R13 R20-R23, R30	124-112	O	Output terminal (Setting for address bus may be selected by mask option)
R31	111	O	Output terminal (DC, address or \overline{WR} output may be selected by mask option)
R32	110	O	Output terminal (DC or \overline{RD} output may be selected by mask option)
R33	109	O	Output terminal (DC or \overline{SRDY} output may be selected by mask option)
R40	108	O	Output terminal (DC, CL or \overline{FOUT} output may be selected by mask option)
R41	107	O	Output terminal (DC or FR output may be selected by mask option)
R42	106	O	Output terminal (DC, BZ or FOUT output may be selected by mask option)
R43	105	O	Output terminal (DC or BZ output may be selected by mask option)
SIN	78	I	Serial interface input terminal
SOUT	77	O	Serial interface output terminal
SCLK	76	I/O	Serial interface clock input/output terminal
SEG0-50	74-51, 49-37 34-21	O	LCD segment output terminal
COM0-15	4-18, 20	O	LCD common output terminal
RESET	126	I	Initial reset input terminal
TEST	127	I	Test input terminal

BASIC EXTERNAL CONNECTION DIAGRAM

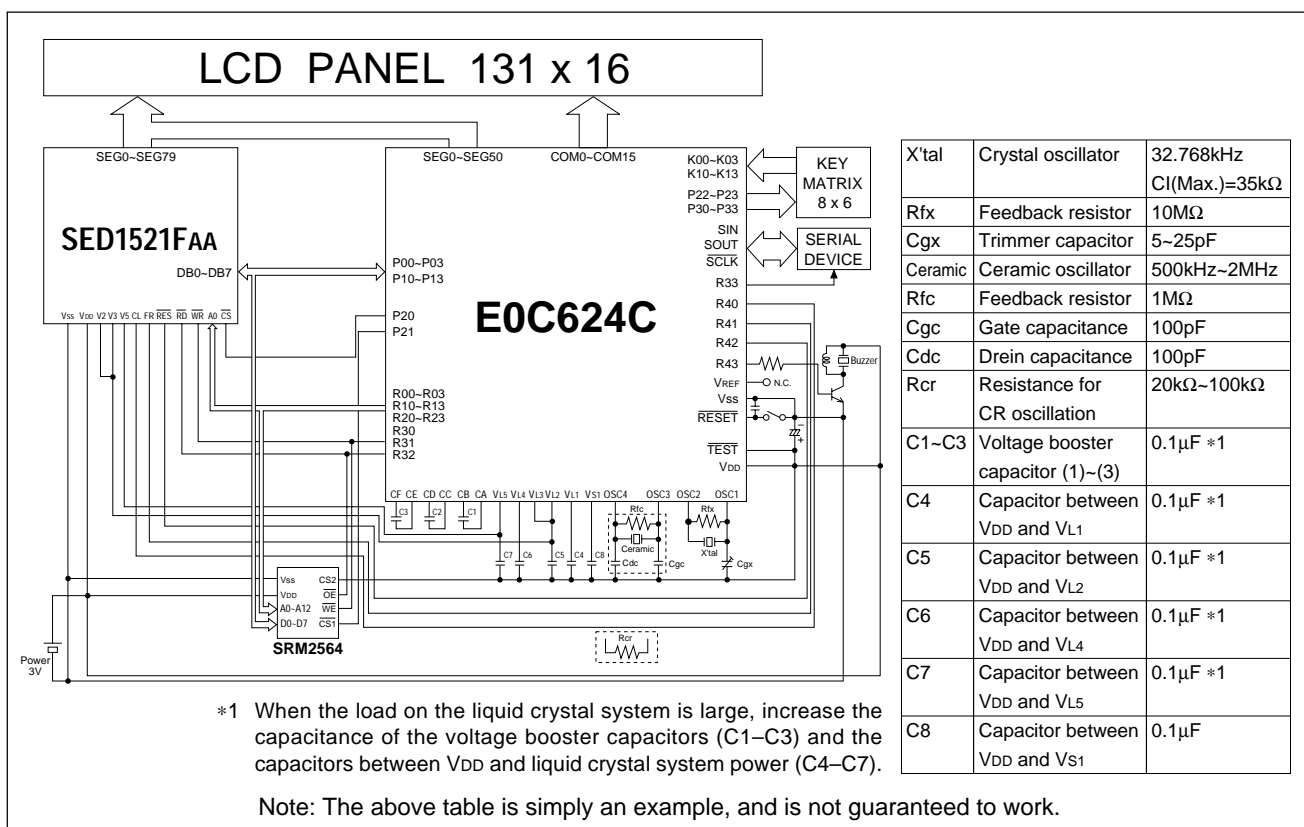

E0C624C

■ ELECTRICAL CHARACTERISTICS

● Absolute Maximum Ratings

(V_{DD}=0V)

Rating	Symbol	Value	Unit
Supply voltage	V _{SS}	-7.0 to 0.5	V
Input voltage (1)	V _I	V _{SS} - 0.3 to 0.5	V
Input voltage (2)	V _I OSC	V _{S1} - 0.3 to 0.5	V
Operating temperature	T _{OPR}	-20 to 70	°C
Storage temperature	T _{STG}	-65 to 150	°C
Soldering temperature / Time	T _{SOL}	260°C, 10sec (lead section)	—
Permissible dissipation *1	P _D	250	mW

*1: In case of plastic package (QFP8-144pin).

● Recommended Operating Conditions

(T_a=-20 to 70°C)

Condition	Symbol	Remark	Min.	Typ.	Max.	Unit	
Supply voltage	V _{SS}	V _{DD} =0V	V _{SC} ="0"	-3.8	-3.0	-1.8	V
			V _{SC} ="1"	-5.5	-3.0	-2.2	V
			V _{SC} ="2"	-5.5	-3.0	-3.5	V
Oscillation frequency (1)	f _{OSC1}		20	32.768	50	kHz	
Oscillation frequency (2)	f _{OSC3}	V _{SC} ="1"	50	1,000	1,200	kHz	
Oscillation frequency (3)	f _{OSC3}	V _{SC} ="2"	50	2,000	2,300	kHz	
Voltage booster capacitor (1)	C1			0.1		μF	
Voltage booster capacitor (2)	C2			0.1		μF	
Voltage booster capacitor (3)	C3			0.1		μF	
Capacitor between V _{DD} and VL1	C4			0.1		μF	
Capacitor between V _{DD} and VL2	C5			0.1		μF	
Capacitor between V _{DD} and VL4	C6			0.1		μF	
Capacitor between V _{DD} and VL5	C7			0.1		μF	
Capacitor between V _{DD} and VS1	C8			0.1		μF	

● DC Characteristics

(Unless otherwise specified: V_{DD}=0V, V_{SS}=-3.0V, VL1=-1.0V, VL2=-2.0V, VL4=-3.0V, VL5=-4.0V, f_{OSC1}=32.768kHz, f_{OSC3}=1MHz, T_a=25°C, C1-C8=0.047μF)

Characteristic	Symbol	Condition	Min.	Typ.	Max.	Unit
High level input voltage	V _{HIN}	V _{SS} =-2.2 to -5.5V	0.2•V _{SS}		0	V
Low level input voltage	V _{LIN}	T _a =25°C	V _{SS}		0.8•V _{SS}	V
High level input voltage	V _{HIN}	V _{SS} =-2.2 to -5.5V	-0.2		0	V
Low level input voltage	V _{LIN}	T _a =25°C	V _{SS}		V _{SS} +0.2	V
High level input current	I _{IH}	V _{SS} =-3.0V V _{IH} =0V	0		0.5	μA
Low level input current (1)	I _{IL1}	V _{SS} =-3.0V V _{IL1} =V _{SS} With pull-up resistor	-45		-15	μA
Low level input current (2)	I _{IL2}	V _{SS} =-3.0V V _{IL2} =V _{SS} No pull-up resistor	-0.5		0	μA
High level output current (1)	I _{OH1}	V _{SS} =-2.2V V _{OH1} =-0.5V			-1.0	mA
Low level output current (1)	I _{OL1}	V _{SS} =-2.2V V _{OL1} =V _{SS} +0.5V	4.0			mA
High level output current (2)	I _{OH2}	V _{SS} =-2.2V V _{OH2} =-0.5V			-2.0	mA
Low level output current (2)	I _{OL2}	V _{SS} =-2.2V V _{OL1} =V _{SS} +0.5V	8.0			mA
Common output current	I _{OH3}	V _{OH3} =-0.05V			-30	μA
	I _{OL3}	V _{OL3} =V _{L5} +0.05V	30			μA
Segment output current	I _{OH4}	V _{OH4} =-0.05V			-10	μA
	I _{OL4}	V _{OL4} =V _{L5} +0.05V	10			μA

● Analog Circuit Characteristics and Current Consumption

(Unless otherwise specified: $V_{DD}=0V$, $V_{SS}=-3.0V$, $V_{L1}=-1.0V$, $V_{L2}=-2.0V$, $V_{L4}=-3.0V$, $V_{L5}=-4.0V$, $f_{osc1}=32.768kHz$, $f_{osc3}=1MHz$, $T_a=25^{\circ}C$, $C_1-C_8=0.047\mu F$)

Characteristic	Symbol	Condition	Min.	Typ.	Max.	Unit	
Liquid crystal drive voltage (Normal mode)	VL1	Connect 1MΩ load resistor between V _{DD} and VL1 (No panel load)	1/2•VL2		1/2•VL2	V	
			-0.1		×0.95		
	VL2	Connect 1MΩ load resistor between V _{DD} and VL2 (No panel load)	LC="0"	Typ.×1.12	-1.80	Typ.×0.88	V
			LC="1"		-1.85		
			LC="2"		-1.90		
			LC="3"		-1.95		
			LC="4"		-2.01		
			LC="5"		-2.06		
			LC="6"		-2.11		
			LC="7"		-2.17		
			LC="8"		-2.22		
			LC="9"		-2.27		
			LC="10"		-2.32		
			LC="11"		-2.38		
			LC="12"		-2.43		
LC="13"	-2.48						
LC="14"	-2.53						
LC="15"	-2.59						
VL4	Connect 1MΩ load resistor between V _{DD} and VL4 (No panel load)	3/2•VL2		3/2•VL2	V		
VL5	Connect 1MΩ load resistor between V _{DD} and VL5 (No panel load)	2•VL2		2•VL2	V		
				×0.95			
Liquid crystal drive voltage (Heavy load protection mode)	VL1	Connect 1MΩ load resistor between V _{DD} and VL1 (No panel load)	Typ.×1.12	-0.92	Typ.×0.88	V	
				LC="1"			-0.95
				LC="2"			-0.97
				LC="3"			-1.00
				LC="4"			-1.03
				LC="5"			-1.05
				LC="6"			-1.08
				LC="7"			-1.11
				LC="8"			-1.13
				LC="9"			-1.16
				LC="10"			-1.18
				LC="11"			-1.21
				LC="12"			-1.24
	LC="13"	-1.26					
	LC="14"	-1.29					
	LC="15"	-1.32					
	VL2	Connect 1MΩ load resistor between V _{DD} and VL2 (No panel load)	2•VL1		2•VL1	V	
VL4	Connect 1MΩ load resistor between V _{DD} and VL4 (No panel load)	3•VL1		3•VL1	V		
VL5	Connect 1MΩ load resistor between V _{DD} and VL5 (No panel load)	4•VL1		4•VL1	V		
				×0.90			
SVD voltage	V _{SVD0}	SVC="0"	-2.35	-2.20	-2.05	V	
	V _{SVD1}	SVC="1"	-2.70	-2.50	-2.30	V	
	V _{SVD2}	SVC="2"	-3.30	-3.10	-2.90	V	
	V _{SVD3}	SVC="3"	-4.50	-4.20	-3.90	V	
SVD circuit response time	t _{SVD}			100	μs		
Current consumption	I _{hlt}	During HALT	No panel load *1	2.5	5.0	μA	
	I _{EX1}	During operation at 32kHz		6.5	9.0	μA	
	I _{EX2}	During operation at 1MHz	No panel load *2	400	600	μA	
	I _{EX3}	During operation at 2MHz	No panel load *3	1,000	1,500	μA	
Current consumption (OSC1•CR oscillation)	I _{hlt}	During HALT	No panel load *4	20	70	μA	
	I _{EX1}	During operation at f _{osc1}		25	80	μA	
	I _{EX2}	During operation at 1MHz		420	600	μA	
	I _{EX3}	During operation at 2MHz	No panel load *5	1,000	1,500	μA	

*1: SVD circuit: OFF status, VSC = "0", OSC1: oscillating with crystal, OSCC = "0"

*2: SVD circuit: OFF status, VSC = "1", OSC1: oscillating with crystal

*3: SVD circuit: OFF status, VSC = "2", OSC1: oscillating with crystal, V_{SS} = -5.0V

*4: SVD circuit: OFF status, VSC = "0" or "1", OSC1: oscillating with CR, OSCC = "0", Rosc for OSC1 = 1.6MΩ

*5: SVD circuit: OFF status, VSC = "2", OSC1: oscillating with CR, OSCC = "0", Rosc for OSC1 = 1.6MΩ

E0C624C

● Oscillation Characteristics

The oscillation characteristics change depending on the conditions (components used, board pattern, etc.). Use the following characteristics as reference values.

OSC1 crystal oscillation circuit

(Unless otherwise specified: $V_{DD}=0V$, $V_{SS}=-3.0V$, Crystal: C-002R ($C_I=35k\Omega$), $C_{Gx}=25pF$, $C_{Dx}=\text{built-in}$, $R_{fx}=10M\Omega$, $VSC="0"$, $T_a=25^\circ C$)

Characteristic	Symbol	Condition	Min.	Typ.	Max.	Unit
Oscillation start time	t_{sta}	$V_{SS}=-2.2$ to $-5.5V$			5	Sec
Built-in capacitance (drain)	C_D	Package as assembled		22		pF
		Bare chip		21		pF
Frequency/voltage deviation	$\partial f/\partial V$	$V_{SS}=-2.2$ to $-5.5V$			5	ppm
Frequency/IC deviation	$\partial f/\partial IC$		-10		10	ppm
Frequency adjustment range	$\partial f/\partial C_G$	$C_G=5$ to $25pF$	35	45		ppm
Harmonic oscillation start voltage	V_{hho}	$C_G=5pF$			-5.5	V
Permitted leak resistance	R_{leak}	Between OSC1 and V_{DD} , V_{S1}	200			$M\Omega$

OSC1 CR oscillation circuit

(Unless otherwise specified: $V_{DD}=0V$, $V_{SS}=-3.0V$, $VSC="0"$ or $"1"$, $T_a=25^\circ C$)

Characteristic	Symbol	Condition	Min.	Typ.	Max.	Unit
Oscillation start time	t_{sta}	$V_{SS}=-2.2$ to $-5.5V$			3	mS
Frequency/voltage deviation	$\partial f/\partial V$	$V_{SS}=-2.2$ to $-5.5V$	-5		5	%
Oscillation frequency	f_{CR}	$R_{osc}=1.6M\Omega$	$32\times 70\%$	32	$32\times 130\%$	kHz

OSC3 CR oscillation circuit (1)

(Unless otherwise specified: $V_{DD}=0V$, $V_{SS}=-3.0V$, $VSC="1"$, $T_a=25^\circ C$)

Characteristic	Symbol	Condition	Min.	Typ.	Max.	Unit
Oscillation start time	t_{sta}	$V_{SS}=-2.2$ to $-5.5V$			3	mS
Frequency/voltage deviation	$\partial f/\partial V$	$V_{SS}=-2.2$ to $-5.5V$	-5		5	%
Oscillation frequency	f_{CR}	$R_{osc}=40k\Omega$	$860\times 70\%$	860	$860\times 130\%$	kHz

OSC3 CR oscillation circuit (2)

(Unless otherwise specified: $V_{DD}=0V$, $V_{SS}=-5.0V$, $VSC="2"$, $T_a=25^\circ C$)

Characteristic	Symbol	Condition	Min.	Typ.	Max.	Unit
Oscillation start time	t_{sta}	$V_{SS}=-3.5$ to $-5.5V$			3	mS
Frequency/voltage deviation	$\partial f/\partial V$	$V_{SS}=-3.5$ to $-5.5V$	-5		5	%
Oscillation frequency	f_{CR}	$R_{osc}=20k\Omega$	$1.7\times 70\%$	1.7	$1.7\times 130\%$	MHz

OSC3 ceramic oscillation circuit (1)

(Unless otherwise specified: $V_{DD}=0V$, $V_{SS}=-3.0V$, $VSC="1"$, Ceramic: CSB 1000J (Murata Mfg. Co.), $C_{Gc}=C_{Dc}=100pF$, $R_{fc}=1M\Omega$, $T_a=25^\circ C$)

Characteristic	Symbol	Condition	Min.	Typ.	Max.	Unit
Oscillation start time	t_{sta}	$V_{SS}=-2.2$ to $-5.5V$			3	mS
Frequency/voltage deviation	$\partial f/\partial V$	$V_{SS}=-2.2$ to $-5.5V$	-3		3	%

OSC3 ceramic oscillation circuit (2)

(Unless otherwise specified: $V_{DD}=0V$, $V_{SS}=-5.0V$, $VSC="2"$, Ceramic: CSA 2.00MG (Murata Mfg. Co.), $C_{Gc}=C_{Dc}=100pF$, $R_{fc}=1M\Omega$, $T_a=25^\circ C$)

Characteristic	Symbol	Condition	Min.	Typ.	Max.	Unit
Oscillation start time	t_{sta}	$V_{SS}=-3.5$ to $-5.5V$			3	mS
Frequency/voltage deviation	$\partial f/\partial V$	$V_{SS}=-3.5$ to $-5.5V$	-3		3	%

■ PACKAGE DIMENSIONS

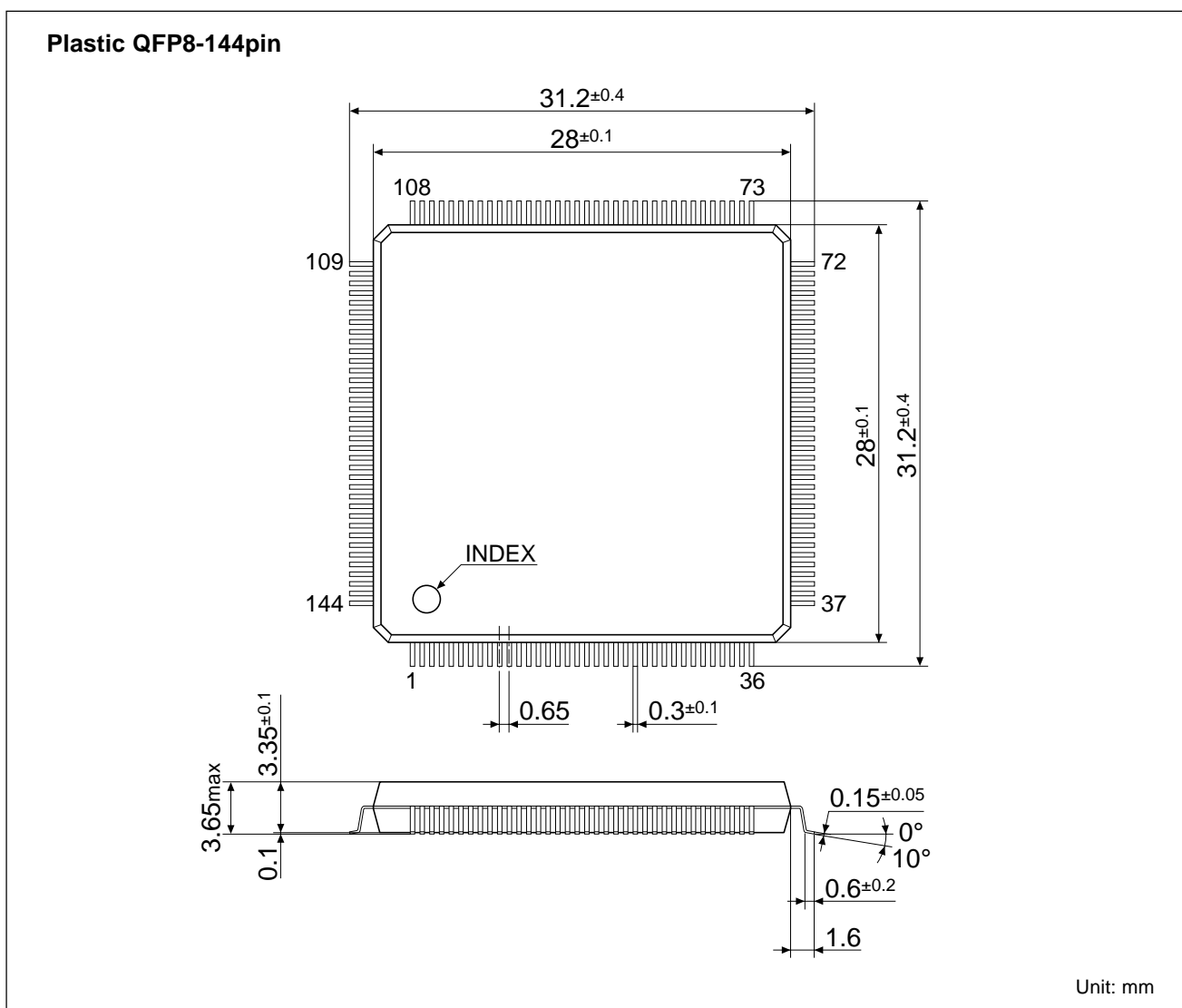

NOTICE:

No part of this material may be reproduced or duplicated in any form or by any means without the written permission of Seiko Epson. Seiko Epson reserves the right to make changes to this material without notice. Seiko Epson does not assume any liability of any kind arising out of any inaccuracies contained in this material or due to its application or use in any product or circuit and, further, there is no representation that this material is applicable to products requiring high level reliability, such as, medical products. Moreover, no license to any intellectual property rights is granted by implication or otherwise, and there is no representation or warranty that anything made in accordance with this material will be free from any patent or copyright infringement of a third party. This material or portions thereof may contain technology or the subject relating to strategic products under the control of the Foreign Exchange and Foreign Trade Control Law of Japan and may require an export license from the Ministry of International Trade and Industry or other approval from another government agency.

© Seiko Epson Corporation 1999 All right reserved.

SEIKO EPSON CORPORATION

ELECTRONIC DEVICES MARKETING DIVISION

IC Marketing & Engineering Group

ED International Marketing Department I (Europe & U.S.A.)

421-8, Hino, Hino-shi, Tokyo 191-8501, JAPAN
Phone : 042-587-5812 FAX : 042-587-5564

ED International Marketing Department II (Asia)

421-8, Hino, Hino-shi, Tokyo 191-8501, JAPAN
Phone : 042-587-5814 FAX : 042-587-5110

