

8 Pin Mini DIP and Mini DIL 5 Tap TTL Compatible Active Delay Lines

Delays are $\pm 5\%$ or ± 2 nS† Tap		DIP Part Number	DIL Part Number	Delays are $\pm 5\%$ or ± 2 nS† Tap		DIP Part Number	DIL Part Number
5, 10, 15, 20	25	EP9458-25	EP9458-25W	30, 60, 90, 120	150	EP9458-150	EP9458-150W
6, 12, 18, 24	30	EP9458-30	EP9458-30W	35, 70, 105, 140	175	EP9458-175	EP9458-175W
7, 14, 21, 28	35	EP9458-35	EP9458-35W	40, 80, 120, 160	200	EP9458-200	EP9458-200W
8, 16, 24, 32	40	EP9458-40	EP9458-40W	45, 90, 135, 180	225	EP9458-225	EP9458-225W
9, 18, 27, 36	45	EP9458-45	EP9458-45W	50, 100, 150, 200	250	EP9458-250	EP9458-250W
10, 20, 30, 40	50	EP9458-50	EP9458-50W	60, 120, 180, 240	300	EP9458-300	EP9458-300W
12, 24, 36, 48	60	EP9458-60	EP9458-60W	70, 140, 210, 280	350	EP9458-350	EP9458-350W
15, 30, 45, 60	75	EP9458-75	EP9458-75W	80, 160, 240, 320	400	EP9458-400	EP9458-400W
20, 40, 60, 80	100	EP9458-100	EP9458-100W	90, 180, 270, 360	450	EP9458-450	EP9458-450W
25, 50, 75, 100	125	EP9458-125	EP9458-125W	100, 200, 300, 400	500	EP9458-500	EP9458-500W

†Whichever is greater. Delay times referenced from input to leading edges at 25°C, 5.0V, with no load.

DC Electrical Characteristics			Min	Max	Unit
Parameter	Test Conditions				
V _{OH}	High-Level Output Voltage	V _{CC} = min. V _{IL} = max. I _{OH} = max	2.7		V
V _{OL}	Low-Level Output Voltage	V _{CC} = min. V _{IH} = min. I _{OL} = max		0.5	V
V _{IK}	Input Clamp Voltage	V _{CC} = min. I _I = I _{IK}		-1.2	V
I _{IH}	High-Level Input Current	V _{CC} = max. V _{IN} = 2.7V		50	μA
		V _{CC} = max. V _{IN} = 5.25V		1.0	mA
I _{IL}	Low-Level Input Current	V _{CC} = max. V _{IN} = 0.5V		-2	mA
I _{OS}	Short Circuit Output Current	V _{CC} = max. V _{OUT} = 0.	-40	-100	mA
		(One output at a time)			
I _{CCH}	High-Level Supply Current	V _{CC} = max. V _{IN} = OPEN		75	mA
I _{CCL}	Low-Level Supply Current	V _{CC} = max. V _{IN} = 0		75	mA
T _{RO}	Output Rise Time	T _d ≤ 500 nS (0.75 to 2.4 Volts)		4	nS
N _H	Fanout High-Level Output	V _{CC} = max. V _{OH} = 2.7V		20 TTL LOAD	
N _L	Fanout Low-Level Output	V _{CC} = max. V _{OL} = 0.5V		10 TTL LOAD	

Schematic

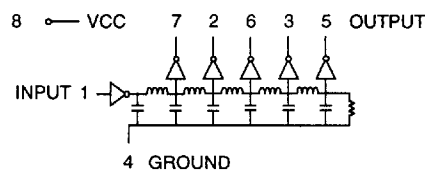

Recommended Operating Conditions		Min	Max	Unit
V _{CC}	Supply Voltage	4.75	5.25	V
V _{IH}	High-Level Input Voltage	2.0		V
V _{IL}	Low-Level Input Voltage		0.8	V
I _{IK}	Input Clamp Current		-18	mA
I _{OH}	High-Level Output Current		-1.0	mA
I _{OL}	Low-Level Output Current		20	mA
PW*	Pulse Width of Total Delay	40		%
d*	Duty Cycle		40	%
T _A	Operating Free-Air Temperature	0	+70	°C

Input Pulse Test Conditions @ 25° C		Unit
E _{IN}	Pulse Input Voltage	3.2 Volts
PW	Pulse Width % of Total Delay	110 %
TRI	Pulse Rise Time (0.75 - 2.4 Volts)	2.0 nS
PRR	Pulse Repetition Rate @ T _d ≤ 200 nS	1.0 MHz
	Pulse Repetition Rate @ T _d > 200 nS	100 KHz
V _{CC}	Supply Voltage	5.0 Volts

*These two values are inter-dependent.

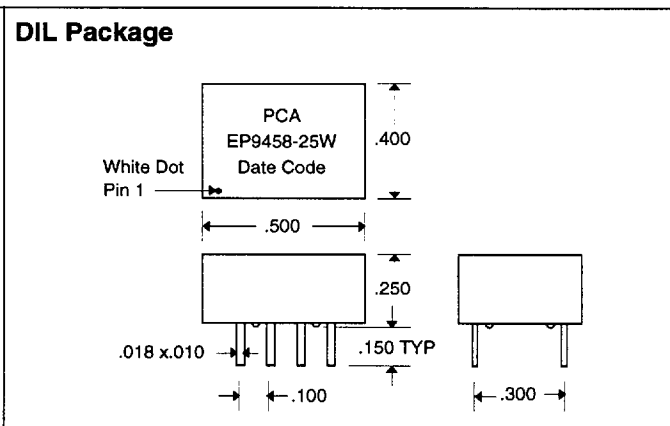
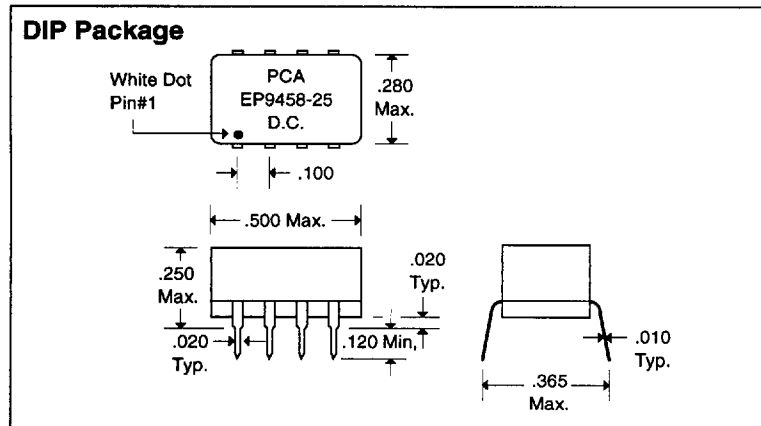

DSD9458 Rev. A 2/5/96

6852109 0000589 256

QAF-CSO1 Rev. B 8/25/94

Unless Otherwise Noted Dimensions in Inches

Tolerances:

Fractional = ± 1/32

30

.XX = ± .030 .XXX = ± .010



16799 SCHOENBORN ST.
NORTH HILLS, CA 91343
TEL: (818) 892-0761
FAX: (818) 894-5791