

# WJ-PA2 / SMPA2

10 to 300 MHz  
TO-8 CASCADABLE AMPLIFIER

- ◆ AVAILABLE IN SURFACE MOUNT
- ◆ HIGH OUTPUT POWER: +25 dBm (TYP.) @ +24 V
- ◆ HIGH EFFICIENCY
- ◆ WIDE POWER SUPPLY RANGE:  
+5 TO +24 VOLTS

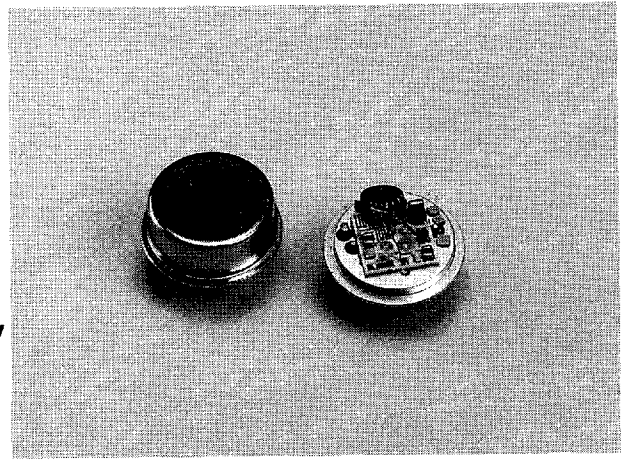

## Specifications \*

Characteristics	Typical	Guaranteed	
		0° to 50°C	-54°C to +85°C
Frequency (Min.)	5-350 MHz	10-300 MHz	10-300 MHz
Small Signal Gain (Min.)	12.5 dB	11.5 dB	11.0 dB
Gain Flatness (Max.)	±0.5 dB	±0.8 dB	±1.0 dB
Noise Figure (Max.)			
V <sub>CC</sub> = +24 Volts	8.0 dB	9.5 dB	10.0 dB
V <sub>CC</sub> = +15 Volts	7.5 dB	9.0 dB	9.5 dB
Power Output			
at 1 dB Compression (Min.)			
V <sub>CC</sub> = +24 Volts	+25 dBm	+24 dBm	+23.5 dBm
V <sub>CC</sub> = +15 Volts	+21 dBm	+19.5 dBm	+19.0 dBm
VSWR (Max.)			
Input	<1.5:1	1.8:1	2.0:1
Output	<1.7:1	2.0:1	2.2:1
DC Current			
At +24 Volts (Max.)	95 mA	100 mA	105 mA
At +15 Volts (Max.)	58 mA	61 mA	64 mA

\* Measured in a 50-ohm system at +24 Vdc Nominal.

### Notes:

1. WJ-CPA2 is a standard WJ-PA2 installed in a miniature SMA connector housing and guaranteed over 0°C to 50°C temperature range.

## Typical Intermodulation Performance at 25°C (At +24 Vdc)

Second Order Harmonic Intercept Point.....+63 dBm (Typ.)  
 Second Order Two Tone Intercept Point.....+56 dBm (Typ.)  
 Third Order Two Tone Intercept Point.....+38 dBm (Typ.)

## Absolute Maximum Ratings (At +24 Vdc)

Storage Temperature .....-62°C to +125°C  
 Maximum Case Temperature .....85°C  
 Maximum DC Voltage.....+25 Volts  
 Maximum Continuous RF Input Power.....+20 dBm  
 Maximum Short Term RF Input Power (1 Minute Max.).....200 Milliwatts  
 Maximum Peak Power.....0.5 Watt (3 µsec Max.)  
 "S" Series Burn-in Temperature (Case).....85°C

Proper heatsinking required to insure reliable performance.

Weight approximately 2.0 grams (0.07 oz)



## Outline Drawings

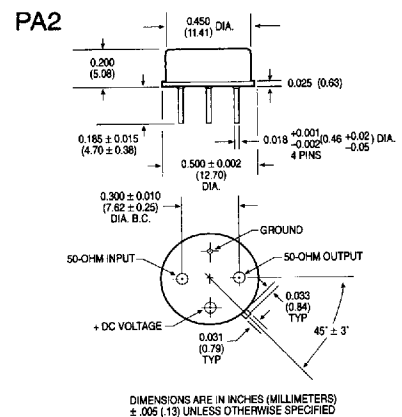

## SMPA2

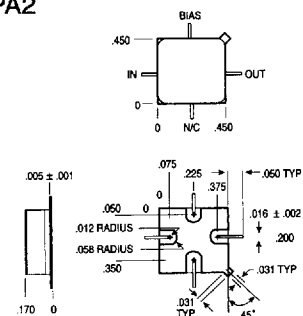

## CPA2

See note 1

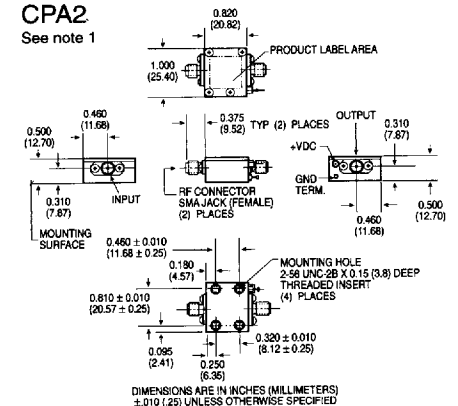

# Typical Performance at 25°C

## Gain

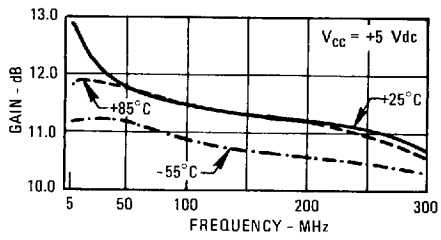
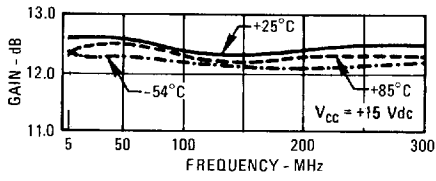
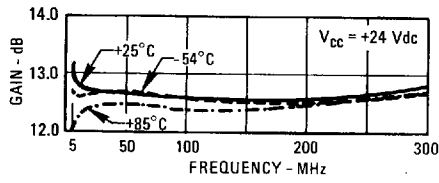

## Noise Figure

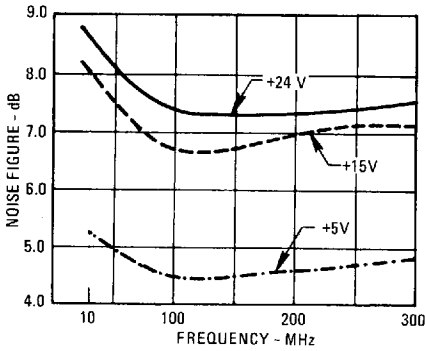

## I<sub>T</sub> vs V<sub>cc</sub>

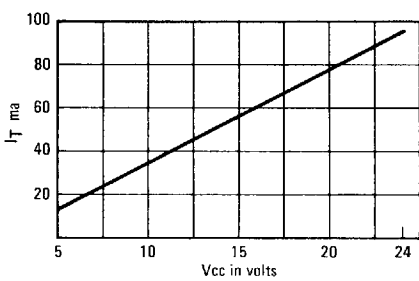

## Power Output\*

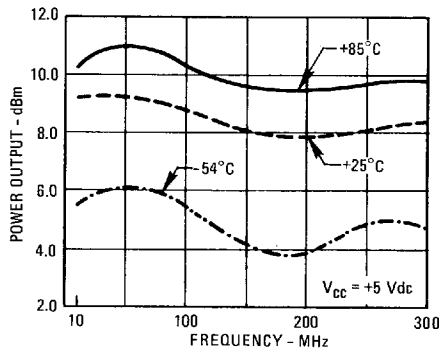
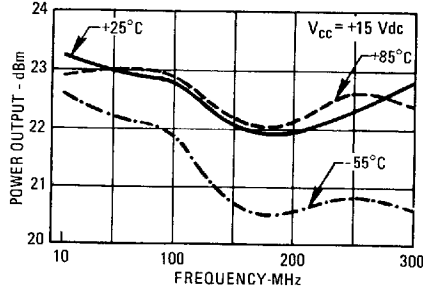
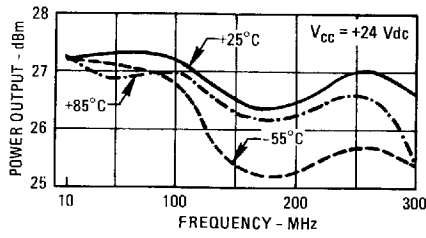

\* at 1 dB Gain Compression

## VSWR

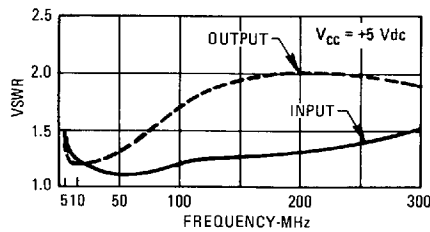
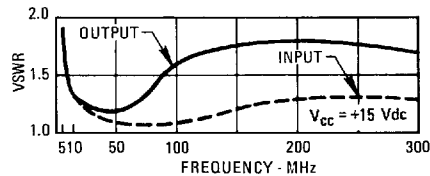
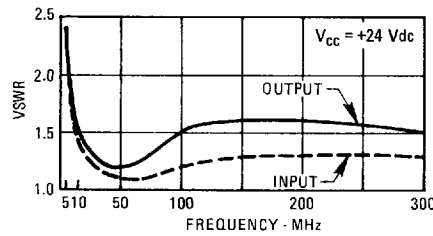

## Harmonics

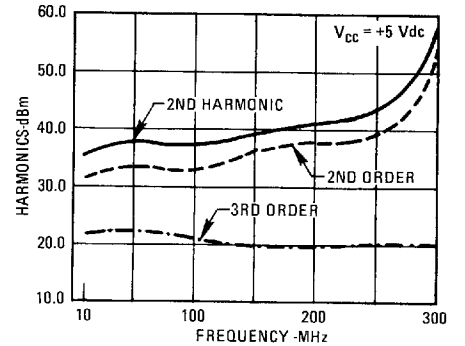
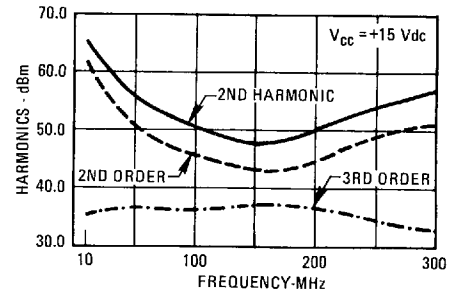
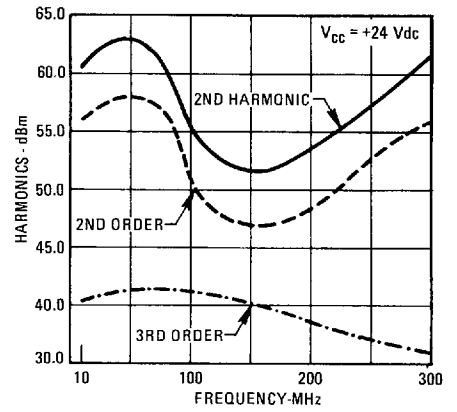

1

## Typical Automatic Test Data

### V<sub>CC</sub> = 24.0 V

Frequency MHz	VSWR IN	VSWR OUT	GAIN DB
5.0	1.5	1.6	13.2
10.0	1.2	1.3	13.1
50.0	1.1	1.2	13.3
100.0	1.0	1.4	13.1
150.0	1.1	1.5	12.8
200.0	1.2	1.6	12.6
250.0	1.3	1.6	12.7
300.0	1.5	1.5	12.9
350.0	1.7	1.4	12.8
400.0	1.7	1.7	12.5

### Linear S-Parameters

Frequency MHz	S11		S21		S12		S22	
	MAG	ANG	MAG	ANG	MAG	ANG	MAG	ANG
5.0	.191	-87	4.564	-169	.116	10	.221	125
10.0	.100	-110	4.509	-177	.124	4	.127	138
50.0	.035	-173	4.615	163	.130	-8	.107	-166
100.0	.005	180	4.497	143	.129	-20	.154	-159
150.0	.041	-56	4.386	124	.128	-29	.199	-169
200.0	.085	-78	4.387	106	.128	-39	.221	176
250.0	.140	-93	4.302	88	.130	-49	.220	153
300.0	.200	-111	4.394	67	.131	-59	.191	121
350.0	.249	-133	4.368	46	.136	-72	.173	67
400.0	.268	-154	4.233	20	.138	-86	.255	2

### V<sub>CC</sub> = 15.0 V

Frequency MHz	VSWR IN	VSWR OUT	GAIN DB
5.0	1.4	1.4	12.9
10.0	1.2	1.2	12.9
50.0	1.1	1.2	13.0
100.0	1.0	1.4	12.8
150.0	1.1	1.6	12.6
200.0	1.2	1.7	12.6
250.0	1.3	1.7	12.4
300.0	1.5	1.6	12.6
350.0	1.7	1.5	12.5
400.0	1.8	1.8	12.1

### Linear S-Parameters

Frequency MHz	S11		S21		S12		S22	
	MAG	ANG	MAG	ANG	MAG	ANG	MAG	ANG
5.0	.158	-94	4.440	-171	.119	9	.180	125
10.0	.090	-114	4.421	-177	.125	4	.104	139
50.0	.040	-175	4.487	162	.129	-8	.100	-155
100.0	.013	177	4.389	142	.128	-19	.166	-152
150.0	.037	-66	4.278	123	.127	-29	.220	-166
200.0	.086	-83	4.257	105	.127	-38	.248	177
250.0	.138	-99	4.182	86	.129	-47	.250	152
300.0	.200	-116	4.248	66	.132	-57	.225	119
350.0	.251	-136	4.209	43	.138	-71	.213	67
400.0	.278	-158	4.044	18	.141	-85	.292	4

### V<sub>CC</sub> = 5.0 V

Frequency MHz	VSWR IN	VSWR OUT	GAIN DB
5.0	1.3	1.3	12.0
10.0	1.2	1.1	12.1
50.0	1.1	1.2	12.1
100.0	1.1	1.5	11.8
150.0	1.2	1.8	11.5
200.0	1.3	1.9	11.3
250.0	1.5	2.0	11.0
300.0	1.7	1.8	10.9
350.0	2.0	1.8	10.6
400.0	2.0	2.1	9.8

### Linear S-Parameters

Frequency MHz	S11		S21		S12		S22	
	MAG	ANG	MAG	ANG	MAG	ANG	MAG	ANG
5.0	.125	-82	3.994	-170	.129	11	.123	111
10.0	.070	-90	4.014	-178	.131	5	.054	111
50.0	.030	-116	4.018	160	.134	-8	.099	-112
100.0	.039	-91	3.874	138	.132	-18	.209	-134
150.0	.088	-81	3.738	117	.131	-27	.284	-158
200.0	.144	-98	3.670	97	.134	-35	.320	178
250.0	.204	-114	3.539	76	.139	-45	.324	150
300.0	.271	-132	3.519	54	.146	-55	.298	114
350.0	.323	-150	3.375	30	.154	-69	.289	62
400.0	.339	-171	3.101	3	.159	-85	.364	3

### Thermal Data: V<sub>CC</sub> = 15 Vdc

Thermal Resistance  $\theta_{jc}$  ..... 45°C/W  
 Transistor Power Dissipation P<sub>d</sub> ..... 1.565 W  
 Junction Temperature Rise Above Case T<sub>jc</sub> ... 70°C