

BIPOLAR LOW VOLTAGE SWITCHING REGULATOR CONTROLLER

- Supply voltage operating range from 1.8 to 15 V
- Low current consumption: 5.5 mA (typical) operating, 1 μ A or less stand-by
- High speed operation up to 1 MHz
- Error amplifier gain is set in the chip to minimize peripheral components
- Soft-start circuit on-chip
- Timer-latch short-circuit detection circuit (SCP) on-chip
- Totem-pole output with adjustable on/off current for NPN transistors
- Stand-by function
- SOP-8, SOL-8 and SSOP-8 packages available

The GM7001 is a single-channel low-voltage switching regulator control IC with soft-start function and short-circuit detection, capable of 1MHz operation. With its low minimum operating voltage of 1.8V and minimal current consumption, the GM7001 is ideal for power supplies in battery-operated equipment.

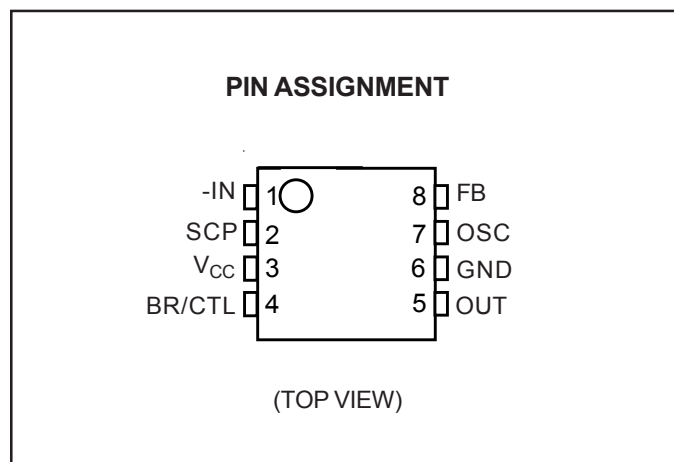

PIN No.	SYMBOL	I/O	DESCRIPTION
1	-IN	I	Error amplifier inverting input pin
2	SCP	-	Soft start and SCP setting capacitor connection pin
3	V _{cc}	-	Power supply pin
4	BR/CTL	I	Output current setting and control pin
5	OUT	O	Totem-pole type output pin
6	GND	-	Ground pin
7	OSC	-	Capacitor and resistor connection pin for setting the oscillation frequency
8	FB	O	Error amplifier output pin

BIPOLAR LOW VOLTAGE SWITCHING REGULATOR CONTROLLER

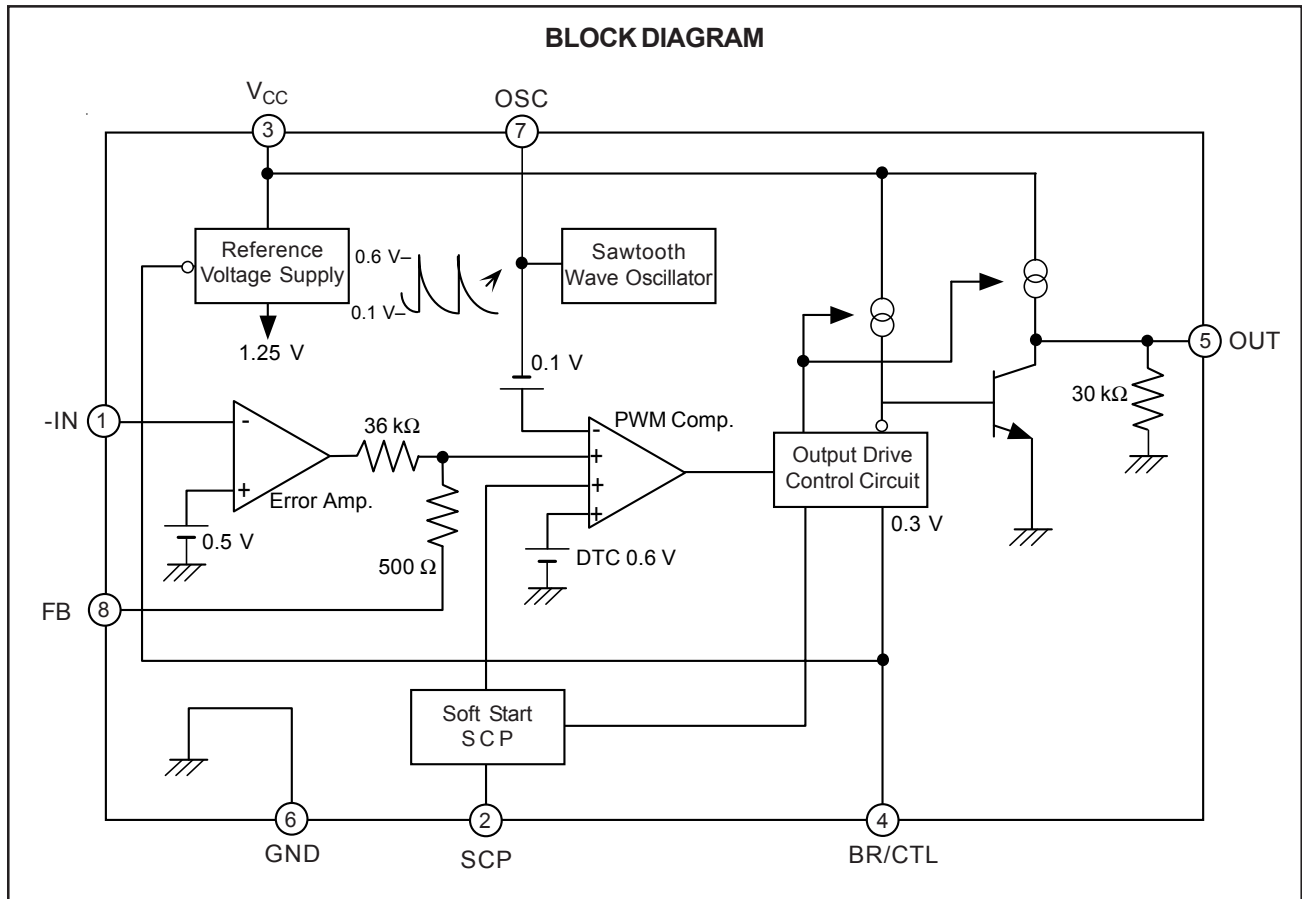

ABSOLUTE MAXIMUM RATINGS

T_A=25°C

PARAMETER	SYMBOL	CONDITION	MIN	MAX	UNITS
Power Supply Voltage	V _{CC}	-	-	16	V
Output Source Current	I _O ⁺	-	-	-50	mA
Output Sink Current	I _O ⁻	-	-	50	ma
Allowable Dissipation	P _D	SOP-8, T _A ≤ +25°C	-	570*	mW
		SOP-8, T _A ≤ +25°C	-	430*	mW
		SSOP-8, T _A ≤ +25°C	-	580*	mW
Operating Temperature	T _{opr}	-	-30	+85	°C
Storage Temperature	T _{stg}	-	-55	+125	°C

* Note: When mounted on a 10 cm square double-sided epoxy board

The devices can be permanently damaged by application of stress (voltage, current, temperature, etc.) in excess of absolute maximum ratings. Do not exceed these ratings. Refer to Recommended Operating Conditions, page 3.

BIPOLAR LOW VOLTAGE SWITCHING REGULATOR CONTROLLER
RECOMMENDED OPERATING CONDITIONS

Parameter	Symbol	MIN.	TYP.	MAX.	Unit
Power supply voltage	V_{CC}	1.8	—	15	V
Error amplifier input voltage	V_I	-0.2	—	1.0	V
BR/CTL pin input voltage	V_{BR}	-0.2	—	V_{CC}	V
Output source current	I_o^+	-40	—	—	mA
Output sink current	I_o^-	—	—	40	mA
SCP pin capacitance	C_{PE}	—	0.1	—	μF
Phase compensation capacitance	C_P	—	0.1	—	μF
Output current setting resistance	R_B	150	390	5000	Ω
Timing resistance	R_T	1.0	3.0	10.0	k Ω
Timing capacitance	C_T	100	270	10000	pF
Oscillation frequency	f_{OSC}	10	500	1000	kHz
Operating temperature	T_{OP}	-30	+25	+85	$^{\circ}C$

NOTE: "Recommended operating conditions" are normal operating ranges for the device. All the device's electrical characteristics are guaranteed when operated within these ranges. Operation outside the recommended ranges may adversely affect reliability and could result in device failure. No warranty is made with respect to uses, operating conditions, or combinations not represented on the data sheet.

BIPOLAR LOW VOLTAGE SWITCHING REGULATOR CONTROLLER
ELECTRICAL CHARACTERISTICS (T_A = 25° C, V_{CC}=+2V)

PARAMETER		SYMBOL	CONDITION	MIN.	TYP.	MAX.	UNIT
Circuit to prevent malfunction at low input voltage (U.V.L.O.)	Reset voltage	V _R	—	—	—	0.9	V
	Threshold voltage	V _{TH}		1.1	1.3	1.5	V
Soft Start	Charging current	I _{CS}	V _{SCP} = 0 V	-1.5	-1.0	-0.7	μA
	Voltage at soft start completion	V _{IS}	—	0.7	0.8	0.9	V
Short Circuit Detection (SCP)	Charging current	I _{CPC}	V _{SCP} = 0 V	-1.5	-1.0	-0.7	μA
	Threshold voltage	V _{IPC}	—	0.7	0.8	0.9	V
Sawtooth Wave Oscillator (OSC)	Oscillation frequency	f _{OCS}	R _T = 3.0 kΩ, C _T = 270 pF	400	500	600	kHz
	Frequency input stability	f _{dV}	V _{CC} = 2 V to 15 V	—	2	10	%
	Frequency variation with temp.	f _{dT}	T _A = -30°C to +85°C	—	5	—	%
Error Amplifier	Input threshold voltage	V _T	V _{FB} = 450 mV	480	500	520	mV
	VT input stability	V _{TdV}	V _{CC} = 2 V to 15 V	—	5	20	mV
	VT variation with temp.	V _{TdT}	T _A = -30°C to +85°C	—	1	—	%
	Input bias current	I _B	V _{IN} = 0 V	-1.0	-0.2	1.0	μA
	Voltage gain	A _V	—	70	100	145	V/V
	Frequency bandwidth	BW	A _V = 0 dB	—	6	—	MHz
	Maximum output voltage range	V _{OM+}	—	0.78	0.87	—	V
		V _{OM-}		—	0.05	0.2	V
	Output source current	I _{OM+}	V _{FB} = 0.45 V	—	-40	-24	μA
Output sink current	I _{OM-}	24		40	—	μA	
Idle Period Adjustment Section	Maximum duty cycle	t _{DUTY}	R _T = 3.0 kΩ, C _T = 270 pF, V _{FB} = 0.8V	65	75	85	%
Output Section	Output voltage	V _{OH1}	R _B = 390 Ω, I _O = -15 mA	1.0	1.2	—	V
		V _{OH2}	R _B = 750 Ω, V _{CC} = 1.8 V, I _O = -10 mA	0.8	1.0	—	V
		V _{OL1}	R _B = 390 Ω, I _O = 15 mA	—	0.1	0.2	V
		V _{OL2}	R _B = 750 Ω, V _{CC} = 1.8 V, I _O = 10 mA	—	0.1	0.2	V
	Output source current	I _{O+}	R _B = 390 Ω, V _O = 0.9 V	—	-30	-20	mA
	Output sink current	I _{O-}	R _B = 390 Ω, V _O = 0.3 V	30	60	—	mA
	Pull down resistance	R _O	—	20	30	40	kΩ
Output Current Setting Section / Control Section	Pin voltage	V _{BR}	R _B = 390 Ω	0.2	0.3	0.4	V
	Input off condition	I _{OFF}	—	-20	—	0	μA
	Input on condition	I _{ON}		—	—	-45	μA
	Pin current range	I _{BR}		-1.8	—	-0.1	mA
Entire Device	Stand-by current	I _{CCS}		BR/CTL pin open or V _{CC}	—	—	1
	Average supply current	I _{CC}	R _B = 390 Ω	—	5.5	9.3	mA

BIPOLAR LOW VOLTAGE SWITCHING REGULATOR CONTROLLER

SETTING THE TIME CONSTANT FOR SOFT START AND SHORT CIRCUIT DETECTION

1. Soft Start

At power on, the capacitor C_{PE} connected to the SCP pin begins charging. The PWM comparator compares the soft start setting voltage (as a proportion of the voltage at the SCP pin) with the sawtooth waveform. This comparison controls the ON duty of the OUT pin, causing soft start operation. Upon completion of soft start operation, the voltage at the SCP pin remains low, the soft start setting voltage remains high, and the circuit enters into output short circuit detection wait state.

Soft start time (The time until the output ON duty reaches approximately 50%)

$$t_s [s] \cong 0.35 \times C_{PE} [\mu F]$$

2. Short Circuit Protection

If the switching regulator output suddenly drops due to load effect, the error amplifier output (FB pin) is fixed at V_{OM+} and capacitor C_{PE} begins charging. When the voltage at the SCP pin reaches approximately 0.8V, the output pin is set low and the SCP pin remains low.

Once the protection circuit activates, operation of the circuit can be restored by resetting the power supply.

Short circuit detection time

$$t_{PE} [s] \cong 0.8 \times C_{PE} [\mu F]$$

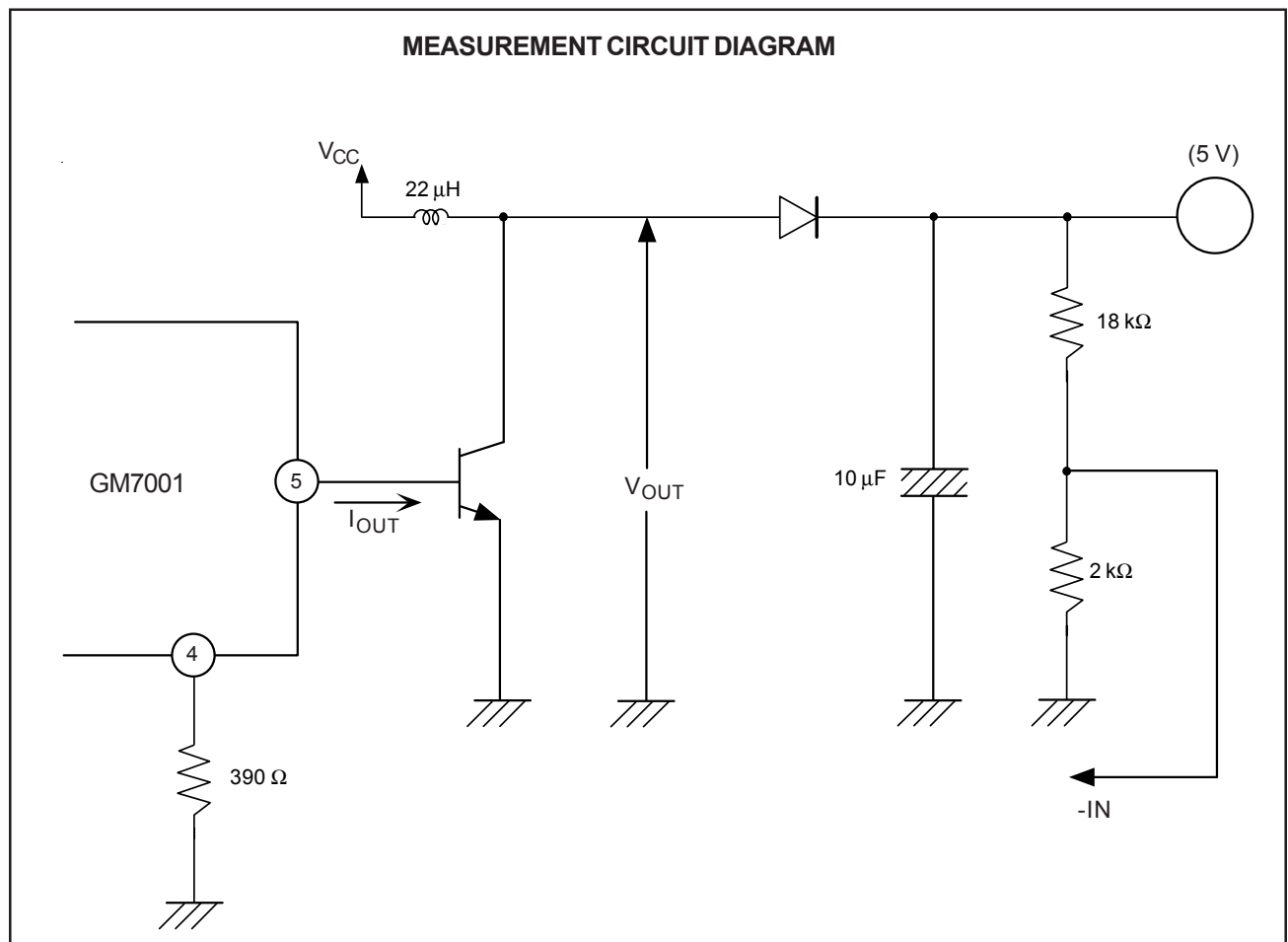

BIPOLAR LOW VOLTAGE SWITCHING REGULATOR CONTROLLER

3. Other Functions

(1) Soft start and short circuit detection

Soft start operation is set by connecting capacitor CPE to the SCP pin (pin 2). Soft start prevents a current spike on start-up. Upon completion of the soft start, the SCP pin (pin 2) remains low and begins the short circuit detection wait state. When an output short circuit occurs, the error amplifier output is fixed at V_{OM+} and capacitor CPE starts charging. After charging to approximately 0.8 V, the output pin (pin 5) is set low and the SCP pin (pin 2) stays low. When the protection circuit is activated, operation of the circuit is restored by resetting the power supply.

(2) Circuit to prevent malfunction at low input voltage

The GM7001 is protected against voltage transients at power-on, or instantaneous glitches in the supply voltage which could lead to malfunction of the control IC and cause system damage or failure. The GM7001's protection circuit to prevent malfunction at low input voltage detects a low input voltage by comparing the supply voltage to the internal reference voltage. On detection, the circuit sets the output pin to Low. The GM7001 recovers when the supply voltage rises above the threshold voltage of the malfunction prevention circuit.

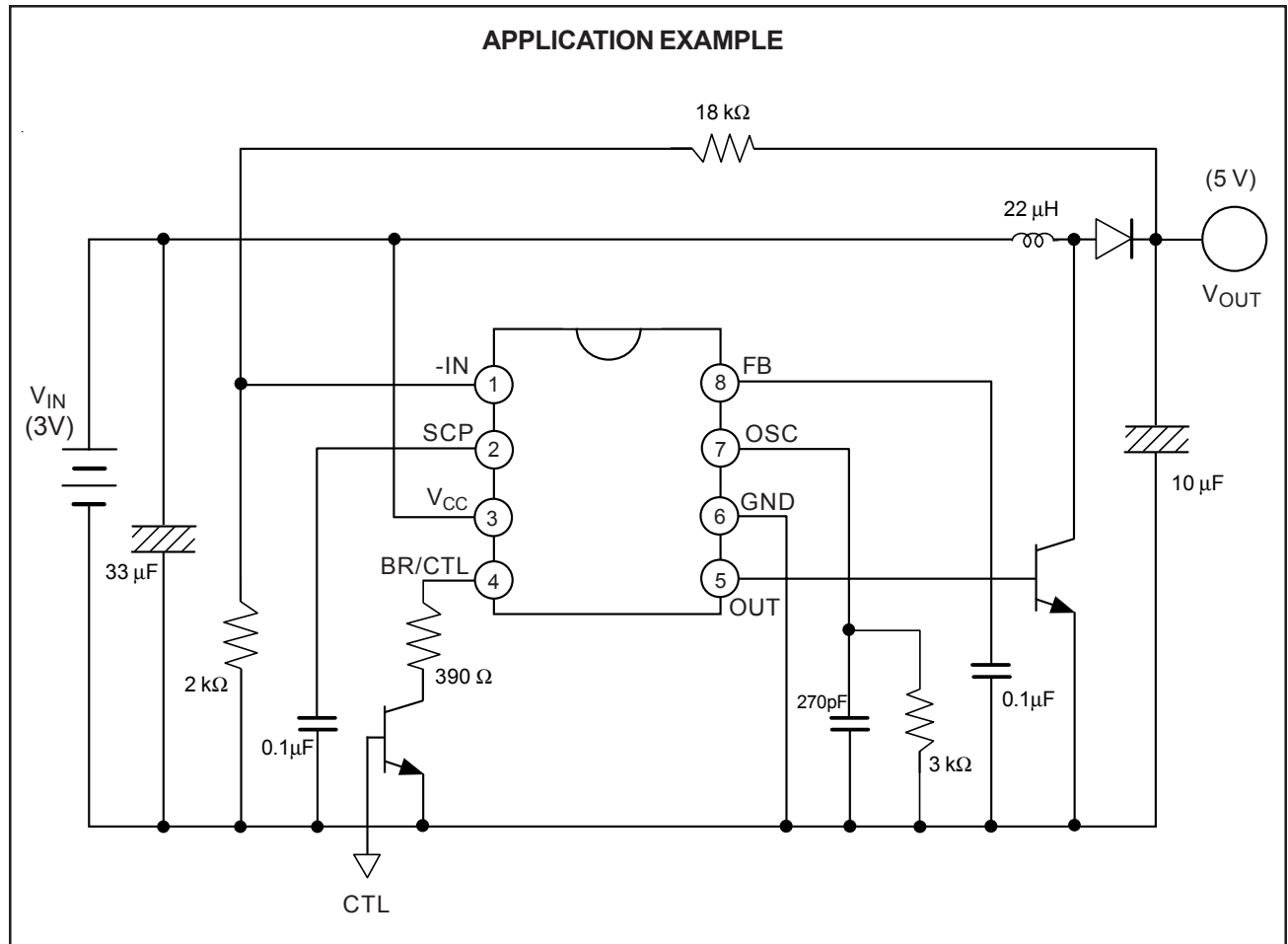

BIPOLAR LOW VOLTAGE SWITCHING REGULATOR CONTROLLER

■ **Switching Regulator Function**

(1) Reference voltage circuit

The reference voltage circuit generates a temperature-compensated reference voltage ($\approx 1.25V$) from voltage supplied via the power supply pin (pin 3). Besides providing the reference voltage for the switching regulator, the circuit sets the idle period.

(2) Sawtooth wave oscillator

The sawtooth oscillator generates a sawtooth wave (up to 1 MHz) that is stable with respect to supply voltage and temperature. The capacitor and resistor that set the oscillation frequency are connected to OSC (pin 7).

(3) Error amplifier

The error amplifier detects the output voltage of the switching regulator and outputs the PWM control signal. The voltage gain is fixed, and connecting a phase compensation capacitor to FB (pin 8) provides stable phase compensation for the system.

(4) PWM comparator

The voltage comparator has one inverting and three non-inverting inputs. The comparator is a voltage/pulse-width converter that controls the ON time of the output pulse depending on the input voltage. The output level is high (H) when the sawtooth wave is lower than the error amplifier output voltage, soft-start setting voltage, and idle period setting voltage.

(5) Output circuit

The totem pole output circuit can drive an external NPN transistor directly. The value of the ON/OFF current is set by a resistor connected to BR/CTL (pin 4).

■ **Power Supply Control Function**

Stand-by mode (supply current 1 μA or less) can be set by connecting the BR/CTL pin (pin 4) to V_{CC} or by making the pin open circuit.

SW	MODE
OFF	Stand-By Mode
ON	Operating Mode

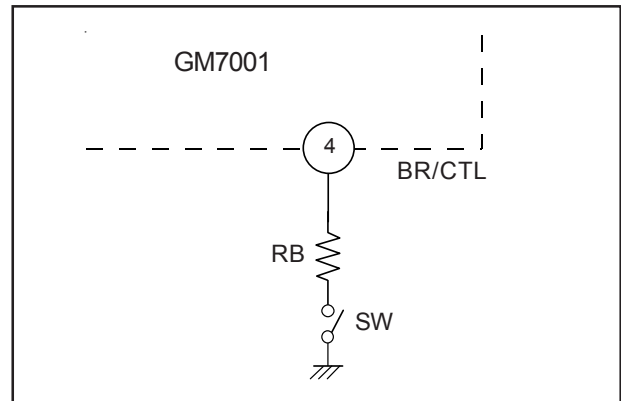

■ **Ordering Information**

GM7001	PACKAGE	PART No.
	SOP-8	GM7001S8
	MSOP8	GM7001M8

BIPOLAR LOW VOLTAGE SWITCHING REGULATOR CONTROLLER

■ **SOP-8 PACKAGE OUTLINE DIMENSIONS**

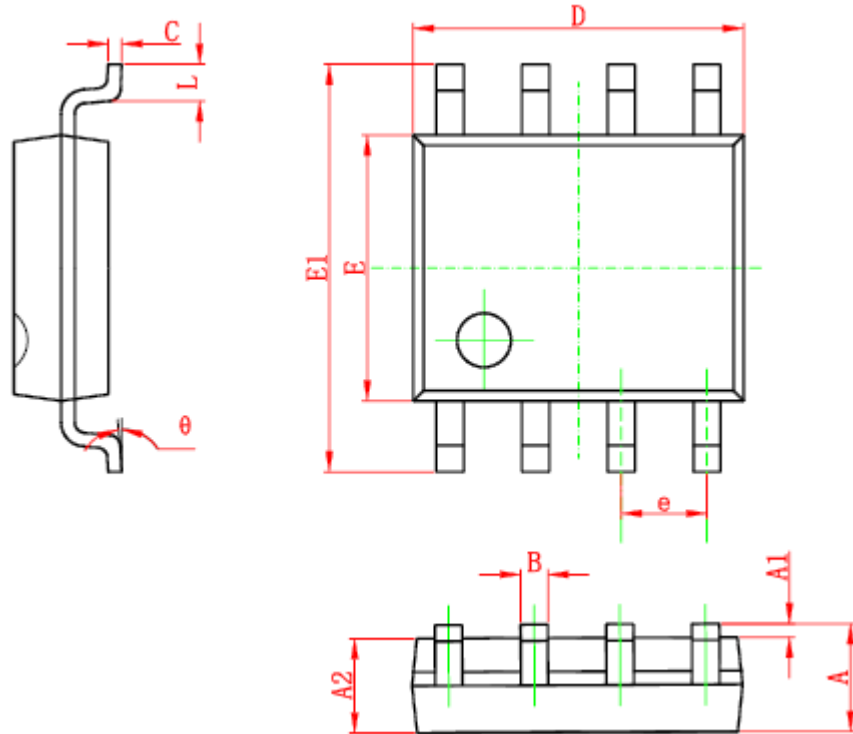

SYMBOL	Dimensions In Millimeters		Dimensions In Inches	
	MIN	MAX	MIN	MAX
A	1.45	1.75	0.057	0.069
A1	0.1	0.25	0.004	0.01
A2	1.35	1.55	0.053	0.061
B	0.306	0.506	0.012	0.02
C	0.153	0.253	0.006	0.01
D	4.81	5.01	0.189	1.197
E	3.84	4.04	0.151	0.159
E1	5.84	6.24	0.23	0.246
e	1.27		0.05	
L	0.45	1	0.018	0.039
θ	0°	8°	0°	8°

BIPOLAR LOW VOLTAGE SWITCHING REGULATOR CONTROLLER

■ **MSOP-8 PACKAGE OUTLINE DIMENSIONS**

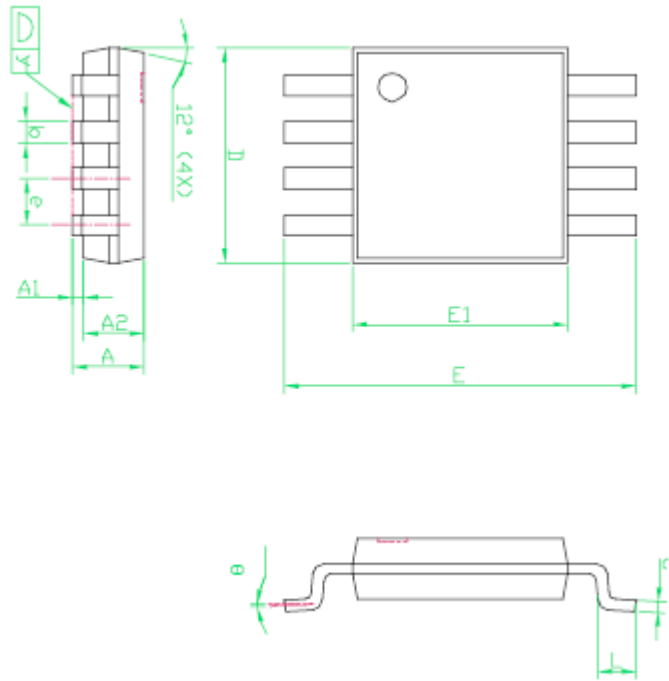

SYMBOL	Dimensions In Millimeters			Dimensions In Inches		
	MIN	NOM	MAX	MIN	NOM	MAX
A	0.81	1.02	1.12	0.032	0.0040	0.048
A1	0.05		0.15	0.002		0.006
A2	0.76	0.86	0.97	0.030	0.034	0.038
b	0.28	0.30	0.38	0.011	0.012	0.015
C	0.13	0.15	0.23	0.005	0.006	0.009
D	2.90	3.00	3.10	0.114	0.118	0.122
E	4.70	4.90	5.10	0.185	0.193	0.201
E1	2.90	3.00	3.10	0.114	0.118	0.122
e		0.65			0.026	
L	0.40	0.53	0.66	0.016	0.021	0.026
y			0.10			0.004
θ	0°		6°	0°		6°

NOTE

1. PACKAGE BODY SIZES EXCLUDE MOLD FLASH AND GATE BURRS
2. DIMENSION L IS MEASURED IN GAGE PLANE
3. TOLERANCE 0.10 mm UNLESS OTHERWISE SPECIFIED
4. CONTROLLING DIMENSION IS MILLIMETER. CONVERTED INCH DIMENSIONS ARE NOT NECESSARILY EXACT.
5. DESIGN FOLLOWING JEDEC MO-187.