

DRAM

MT4LC8M8E1, MT4LC8M8B6

For the latest data sheet, please refer to the Micron Web site: www.micron.com/products/datasheets/dramds.html

FEATURES

- Single +3.3V ±0.3V power supply
- Industry-standard x8 pinout, timing, functions, and packages
- 13 row, 10 column addresses (E1) or 12 row, 11 column addresses (B6)
- High-performance CMOS silicon-gate process
- All inputs, outputs and clocks are LVTTTL-compatible
- FAST PAGE MODE (FPM) access
- 4,096-cycle CAS#-BEFORE-RAS# (CBR) REFRESH distributed across 64ms
- Optional self refresh (S) for low-power data retention

OPTIONS

- Refresh Addressing
 - 4,096 (4K) rows
 - 8,192 (8K) rows
- Plastic Packages
 - 32-pin SOJ (400 mil)
 - 32-pin TSOP (400 mil)
- Timing
 - 50ns access
 - 60ns access
- Refresh Rates
 - Standard Refresh (64ms period)
 - Self Refresh (128ms period)

MARKING

B6
E1

DJ
TG

-5
-6

None
S*

NOTE: 1. The 8 Meg x 8 FPM DRAM base number differentiates the offerings in one place—MT4LC8M8E1. The fifth field distinguishes various options: E1 designates an 8K refresh and B6 designates a 4K refresh for FPM DRAMs.
2. The # symbol indicates signal is active LOW.

*Contact factory for availability

Part Number Example:
MT4LC8M8E1DJ-5

KEY TIMING PARAMETERS

SPEED	t _{RC}	t _{RAC}	t _{PC}	t _{AA}	t _{CAC}
-5	90ns	50ns	30ns	25ns	13ns
-6	110ns	60ns	35ns	30ns	15ns

PIN ASSIGNMENT (Top View)

32-Pin SOJ

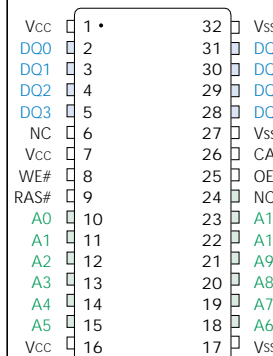

32-Pin TSOP

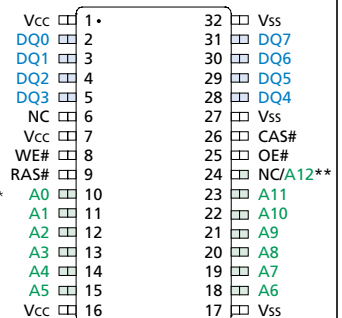

**A12 on E1 version, NC on B6 version

8 MEG x 8 FPM DRAM PART NUMBERS

PART NUMBER	REFRESH ADDRESSING	PACKAGE	REFRESH
MT4LC8M8E1DJ-x	8K	SOJ	Standard
MT4LC8M8E1DJ-x S	8K	SOJ	Self
MT4LC8M8E1TG-x	8K	TSOP	Standard
MT4LC8M8E1TG-x S	8K	TSOP	Self
MT4LC8M8B6DJ-x	4K	SOJ	Standard
MT4LC8M8B6DJ-x S	4K	SOJ	Self
MT4LC8M8B6TG-x	4K	TSOP	Standard
MT4LC8M8B6TG-x S	4K	TSOP	Self

x = speed

GENERAL DESCRIPTION

The 8 Meg x 8 DRAMs are high-speed CMOS, dynamic random-access memory devices containing 67,108,864 bits organized in a x8 configuration. The 8 Meg x 8 DRAMs are functionally organized as 8,388,608 locations containing eight bits each. The 8,388,608 memory locations are arranged in 8,192 rows by 1,024 columns for the MT4LC8M8E1 or 4,096 rows by 2,048 columns for the MT4LC8M8B6. During READ or WRITE cycles, each location is uniquely addressed via the address bits. First, the row address is latched by the

**FUNCTIONAL BLOCK DIAGRAM
MT4LC8M8E1 (13 row addresses)**

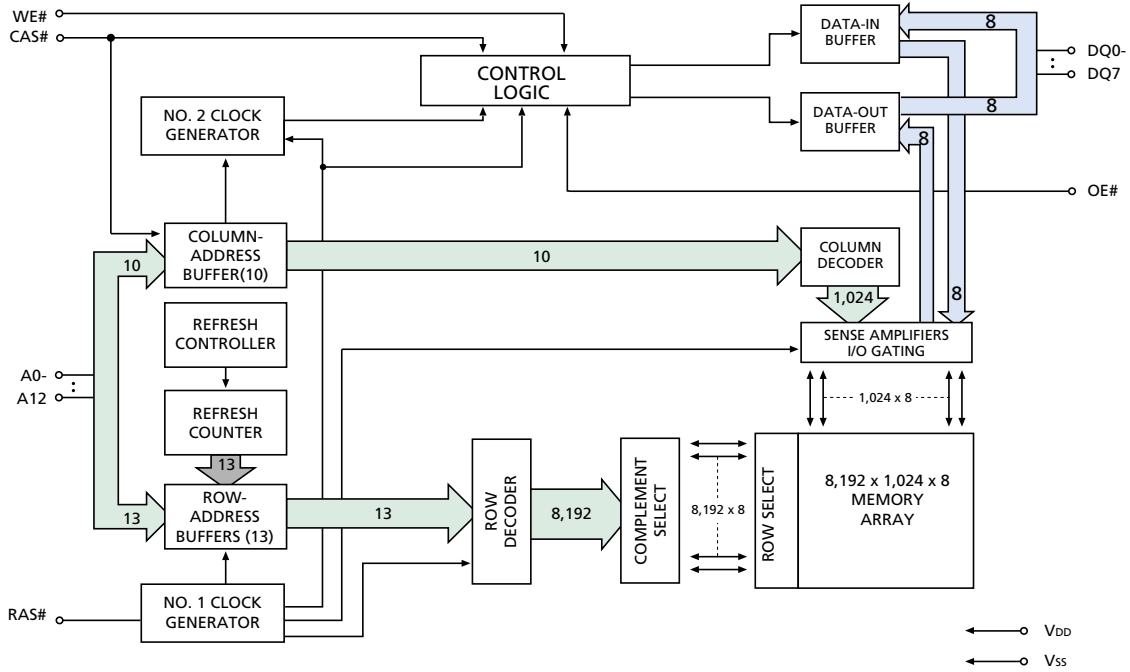

**FUNCTIONAL BLOCK DIAGRAM
MT4LC8M8B6 (12 row addresses)**

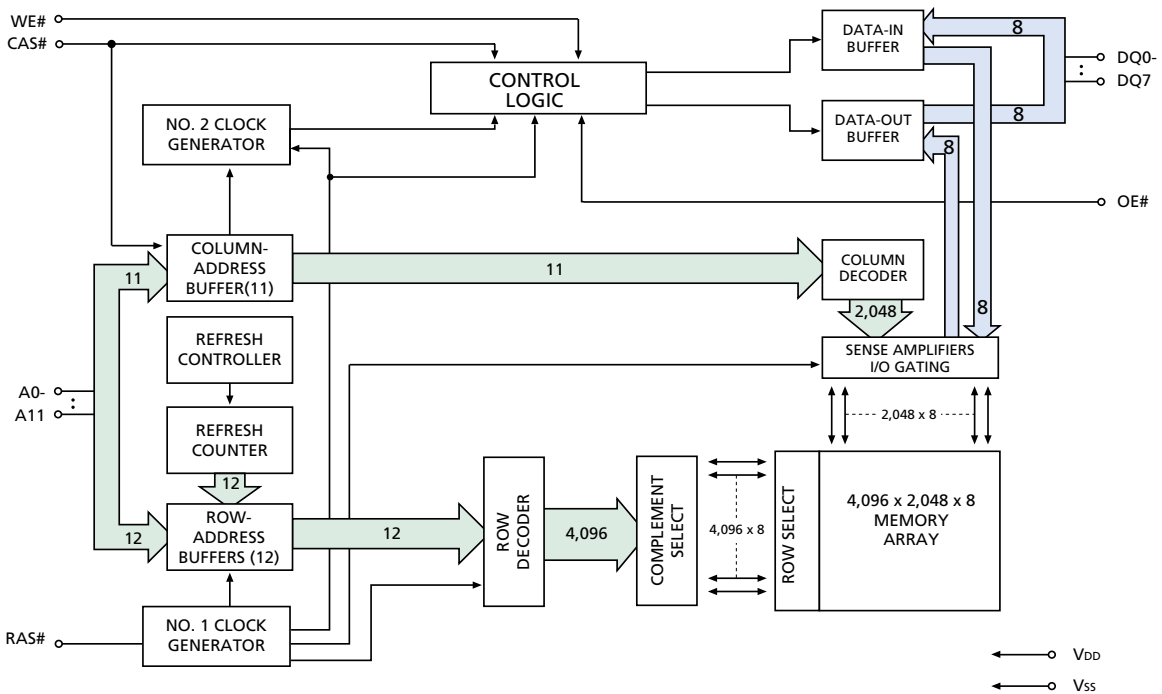

GENERAL DESCRIPTION (continued)

RAS# signal, then the column address by CAS#. Both devices provide FAST-PAGE-MODE operation, allowing for fast successive data operations (READ, WRITE, or READ-MODIFY-WRITE) within a given row.

The MT4LC8M8E1 and MT4LC8M8B6 must be refreshed periodically in order to retain stored data.

FAST PAGE MODE ACCESS

Each location in the DRAM is uniquely addressable as mentioned in the General Description. The data for each location is accessed via the eight I/O pins (DQ0-DQ7). The WE# signal must be activated to execute a WRITE operation; otherwise, a READ operation will be performed. The OE# signal must be activated to enable the DQ output drivers for a read access and can be deactivated to disable output data if necessary.

FAST-PAGE-MODE operations are always initiated with a row address strobed in by the RAS# signal, followed by a column address strobed in by CAS#, just like for single location accesses. However, subsequent column locations within the row may then be accessed at the page mode cycle time. This is accomplished by cycling CAS# while holding RAS# LOW and entering new column addresses with each CAS# cycle. Returning RAS# HIGH terminates the FAST-PAGE-MODE operation.

DRAM REFRESH

The supply voltage must be maintained at the specified levels, and the refresh requirements must be met in order to retain stored data in the DRAM. The refresh requirements are met by refreshing all 8,192 rows (E1) or all 4,096 rows (B6) in the DRAM array at least once every 64ms. The recommended procedure is to execute 4,096 CBR REFRESH cycles, either uniformly spaced or grouped in bursts, every 64ms. The MT4LC8M8E1 internally refreshes two rows for every CBR cycle, whereas

the MT4LC8M8B6 refreshes one row for every CBR cycle. So with either device, executing 4,096 CBR cycles covers all rows. The CBR REFRESH cycle will invoke the internal refresh counter for automatic RAS# addressing. Alternatively, RAS#-ONLY REFRESH capability is inherently provided. However, with this method only one row is refreshed at a time; so for the MT4LC8M8E1, 8,192 RAS#-ONLY REFRESH cycles must be executed every 64ms to cover all rows. Some compatibility issues may become apparent. JEDEC strongly recommends the use of CBR REFRESH for this device.

An optional self refresh mode is also available on the "S" version. The self refresh feature is initiated by performing a CBR REFRESH cycle and holding RAS# LOW for the specified t_{RASS} . The "S" option allows for an extended refresh period of 128ms, or 31.25 μ s per row for a 4K refresh and 15.625 μ s per row for an 8K refresh when using a distributed CBR REFRESH. This refresh rate can be applied during normal operation, as well as during a standby or battery backup mode.

The self refresh mode is terminated by driving RAS# HIGH for a minimum time of t_{RPS} . This delay allows for the completion of any internal refresh cycles that may be in process at the time of the RAS# LOW-to-HIGH transition. If the DRAM controller uses a distributed CBR refresh sequence, a burst refresh is not required upon exiting self refresh. However, if the DRAM controller utilizes RAS#-ONLY or burst CBR refresh sequence, all rows must be refreshed with a refresh rate of t_{RC} minimum prior to the resumption of normal operation.

STANDBY

Returning RAS# and CAS# HIGH terminates a memory cycle and decreases chip current to a reduced standby level. The chip is preconditioned for the next cycle during the RAS# HIGH time.

ABSOLUTE MAXIMUM RATINGS*

Voltage on V_{CC} Relative to V_{SS} -1V to +4.6V
 Voltage on NC, Inputs or I/O Pins
 Relative to V_{SS} -1V to +4.6V
 Operating Temperature, T_A (ambient) ... 0°C to +70°C
 Storage Temperature (plastic) -55°C to +150°C
 Power Dissipation 1W

*Stresses greater than those listed under “Absolute Maximum Ratings” may cause permanent damage to the device. This is a stress rating only, and functional operation of the device at these or any other conditions above those indicated in the operational sections of this specification is not implied. Exposure to absolute maximum rating conditions for extended periods may affect reliability.

DC ELECTRICAL CHARACTERISTICS AND OPERATING CONDITIONS

 (Notes: 1, 5, 6) (V_{CC} = +3.3V ±0.3V)

PARAMETER/CONDITION	SYMBOL	MIN	MAX	UNITS	NOTES
SUPPLY VOLTAGE	V _{CC}	3	3.6	V	
INPUT HIGH VOLTAGE: Valid Logic 1; All inputs, I/Os and any NC	V _{IH}	2	V _{CC} + 0.3	V	26
INPUT LOW VOLTAGE: Valid Logic 0; All inputs, I/Os and any NC	V _{IL}	-0.3	0.8	V	26
INPUT LEAKAGE CURRENT: Any input at V _{IN} (0V ≤ V _{IN} ≤ V _{CC} + 0.3V); All other pins not under test = 0V	I _I	-2	2	μA	
OUTPUT HIGH VOLTAGE: I _{OUT} = -2mA	V _{OH}	2.4	-	V	
OUTPUT LOW VOLTAGE: I _{OUT} = 2mA	V _{OL}	-	0.4	V	
OUTPUT LEAKAGE CURRENT: Any output at V _{OUT} (0V ≤ V _{OUT} ≤ V _{CC} + 0.3V); DQ is disabled and in High-Z state	I _{OZ}	-5	5	μA	

I_{CC} OPERATING CONDITIONS AND MAXIMUM LIMITS

 (Notes: 1, 2, 3, 5, 6) ($V_{CC} = +3.3V \pm 0.3V$)

PARAMETER/CONDITION	SYMBOL	SPEED	4K REFRESH	8K REFRESH	UNITS	NOTES
STANDBY CURRENT: TTL (RAS# = CAS# = V_{IH})	I _{CC1}	ALL	1	1	mA	
STANDBY CURRENT: CMOS (RAS# = CAS# $\geq V_{CC} - 0.2V$; DQs may be left open; Other inputs: $V_{IN} \cdot V_{CC} - 0.2V$ or $V_{IN} \leq 0.2V$)	I _{CC2}	ALL	500	500	μA	
OPERATING CURRENT: Random READ/WRITE Average power supply current (RAS#, CAS#, address cycling: $t_{RC} = t_{RC} [MIN]$)	I _{CC3}	-5 -6	175 165	135 125	mA	25
OPERATING CURRENT: FAST PAGE MODE Average power supply current (RAS# = V_{IL} , CAS#, address cycling: $t_{PC} = t_{PC} [MIN]$)	I _{CC4}	-5 -6	105 95	105 95	mA	25
REFRESH CURRENT: RAS#-ONLY Average power supply current (RAS# cycling, CAS# = V_{IH} : $t_{RC} = t_{RC} [MIN]$)	I _{CC5}	-5 -6	175 165	135 125	mA	22
REFRESH CURRENT: CBR Average power supply current (RAS#, CAS#, address cycling: $t_{RC} = t_{RC} [MIN]$)	I _{CC6}	-5 -6	175 165	175 165	mA	4, 7
REFRESH CURRENT: Extended ("S" version only) Average power supply current: CAS# = 0.2V or CBR cycling; RAS# = $t_{RAS} (MIN)$; WE# = $V_{CC} - 0.2V$; A0-A11, OE# and D _{IN} = $V_{CC} - 0.2V$ or 0.2V (D _{IN} may be left open)	I _{CC7}	ALL	400	400	μA	4, 7
REFRESH CURRENT: Self ("S" version only) Average power supply current: CBR with RAS# $\cdot t_{RASS} (MIN)$ and CAS# held LOW; WE# = $V_{CC} - 0.2V$; A0-A11, OE# and D _{IN} = $V_{CC} - 0.2V$ or 0.2V (D _{IN} may be left open)	I _{CC8}	ALL	400	400	μA	4, 7

CAPACITANCE

(Note: 2)

PARAMETER	SYMBOL	MAX	UNITS
Input Capacitance: Address pins	C _{I1}	5	pF
Input Capacitance: RAS#, CAS#, WE#, OE#	C _{I2}	7	pF
Input/Output Capacitance: DQ	C _{IO}	7	pF

AC ELECTRICAL CHARACTERISTICS

(Notes: 5, 6, 7, 8, 9, 10, 11, 12) (V_{CC} = +3.3V ±0.3V)

AC CHARACTERISTICS PARAMETER	SYMBOL	-5		-6		UNITS	NOTES
		MIN	MAX	MIN	MAX		
Access time from column address	t _{AA}		25		30	ns	
Column-address hold time (referenced to RAS#)	t _{AR}	40		45		ns	
Column-address setup time	t _{ASC}	0		0		ns	
Row-address setup time	t _{ASR}	0		0		ns	
Column address to WE# delay time	t _{AWD}	48		55		ns	18
Access time from CAS#	t _{CAC}		13		15	ns	
Column-address hold time	t _{CAH}	8		10		ns	
CAS# pulse width	t _{CAS}	13	10,000	15	10,000	ns	
CAS# LOW to "Don't Care" during Self Refresh	t _{CHD}	15		15		ns	
CAS# hold time (CBR Refresh)	t _{CHR}	15		15		ns	4
CAS# to output in Low-Z	t _{CLZ}	3		3		ns	
CAS# precharge time (FAST PAGE MODE)	t _{CP}	8		10		ns	13
Access time from CAS# precharge	t _{CPA}		30		35	ns	
CAS# to RAS# precharge time	t _{CRP}	5		5		ns	
CAS# hold time	t _{CSH}	50		60		ns	
CAS# setup time (CBR Refresh)	t _{CSR}	5		5		ns	4
CAS# to WE# delay time	t _{CWD}	36		40		ns	18
WRITE command to CAS# lead time	t _{CWL}	13		15		ns	
Data-in hold time	t _{DH}	8		10		ns	19
Data-in setup time	t _{DS}	0		0		ns	19
Output disable	t _{OD}	3	13	3	15	ns	23, 24
Output enable time	t _{OE}		13		15	ns	20
OE# hold time from WE# during READ-MODIFY-WRITE cycle	t _{OEH}	13		15		ns	24
Output buffer turn-off delay	t _{OFF}	3	13	3	15	ns	17, 23
OE# setup prior to RAS# during HIDDEN REFRESH cycle	t _{ORD}	0		0		ns	
FAST-PAGE-MODE READ or WRITE cycle time	t _{PC}	30		35		ns	
FAST-PAGE-MODE READ-WRITE cycle time	t _{PRWC}	76		85		ns	
Access time from RAS#	t _{RAC}		50		60	ns	

AC ELECTRICAL CHARACTERISTICS

(Notes: 5, 6, 7, 8, 9, 10, 11, 12) ($V_{CC} = +3.3V \pm 0.3V$)

AC CHARACTERISTICS		-5		-6			
PARAMETER	SYMBOL	MIN	MAX	MIN	MAX	UNITS	NOTES
RAS# to column-address delay time	t_{RAD}	13		15		ns	15
Row-address hold time	t_{RAH}	8		10		ns	
RAS# pulse width	t_{RAS}	50	10,000	60	10,000	ns	
RAS# pulse width (FAST PAGE MODE)	t_{RASP}	50	125,000	60	125,000	ns	
RAS# pulse width during Self Refresh	t_{RASS}	100		100		μs	
Random READ or WRITE cycle time	t_{RC}	90		110		ns	
RAS# to CAS# delay time	t_{RCD}	18		20		ns	14
READ command hold time (referenced to CAS#)	t_{RCH}	0		0		ns	16
READ command setup time	t_{RCS}	0		0		ns	
Refresh period	t_{REF}		64		64	ms	22
Refresh period (2,048 cycles) "S" version	t_{REF}		128		128	ms	
RAS# precharge time	t_{RP}	30		40		ns	
RAS# to CAS# precharge time	t_{RPC}	5		5		ns	
RAS# precharge time exiting Self Refresh	t_{RPS}	90		105		ns	
READ command hold time (referenced to RAS#)	t_{RRH}	0		0		ns	16
RAS# hold time	t_{RSH}	13		15		ns	
READ-WRITE cycle time	t_{RWC}	131		155		ns	
RAS# to WE# delay time	t_{RWD}	73		85		ns	18
WRITE command to RAS# lead time	t_{RWL}	13		15		ns	
Transition time (rise or fall)	t_T	2	50	2	50	ns	
WRITE command hold time	t_{WCH}	8		10		ns	
WRITE command hold time (referenced to RAS#)	t_{WCR}	40		45		ns	
WE# command setup time	t_{WCS}	0		0		ns	18
WRITE command pulse width	t_{WCP}	8		10		ns	
WE# hold time (CBR Refresh)	t_{WRH}	10		10		ns	
WE# setup time (CBR Refresh)	t_{WRP}	10		10		ns	

NOTES

1. All voltages referenced to V_{SS} .
2. This parameter is sampled. $V_{CC} = +3.3V$; $f = 1$ MHz.
3. I_{CC} is dependent on output loading and cycle rates. Specified values are obtained with minimum cycle time and the outputs open.
4. Enables on-chip refresh and address counters.
5. The minimum specifications are used only to indicate cycle time at which proper operation over the full temperature range is ensured.
6. An initial pause of 100 μ s is required after power-up, followed by eight RAS# refresh cycles (RAS#-ONLY or CBR with WE# HIGH), before proper device operation is ensured. The eight RAS# cycle wake-ups should be repeated any time the t_{REF} refresh requirement is exceeded.
7. AC characteristics assume $t_T = 5ns$.
8. V_{IH} (MIN) and V_{IL} (MAX) are reference levels for measuring timing of input signals. Transition times are measured between V_{IH} and V_{IL} (or between V_{IL} and V_{IH}).
9. In addition to meeting the transition rate specification, all input signals must transit between V_{IH} and V_{IL} (or between V_{IL} and V_{IH}) in a monotonic manner.
10. If CAS# = V_{IH} , data output is High-Z.
11. If CAS# = V_{IL} , data output may contain data from the last valid READ cycle.
12. Measured with a load equivalent to two TTL gates, 100pF and $V_{OL} = 0.8V$ and $V_{OH} = 2V$.
13. If CAS# is LOW at the falling edge of RAS#, output data will be maintained from the previous cycle. To initiate a new cycle and clear the data-out buffer, CAS# must be pulsed HIGH for t_{CP} .
14. The t_{RCD} (MAX) limit is no longer specified. t_{RCD} (MAX) was specified as a reference point only. If t_{RCD} was greater than the specified t_{RCD} (MAX) limit, then access time was controlled exclusively by t_{CAC} (t_{RAC} [MIN] no longer applied). With or without the t_{RCD} limit, t_{AA} and t_{CAC} must always be met.
15. The t_{RAD} (MAX) limit is no longer specified. t_{RAD} (MAX) was specified as a reference point only. If t_{RAD} was greater than the specified t_{RAD} (MAX) limit, then access time was controlled exclusively by t_{AA} (t_{RAC} and t_{CAC} no longer applied). With or without the t_{RAD} (MAX) limit, t_{AA} , t_{RAC} and, t_{CAC} must always be met.
16. Either t_{RCH} or t_{RRH} must be satisfied for a READ cycle.
17. t_{OFF} (MAX) defines the time at which the output achieves the open circuit condition and is not referenced to V_{OH} or V_{OL} .
18. t_{WCS} , t_{RWD} , t_{AWD} , and t_{CWD} are not restrictive operating parameters. t_{WCS} applies to EARLY WRITE cycles. If $t_{WCS} > t_{WCS}$ MIN, the cycle is an EARLY WRITE cycle and the data output will remain an open circuit throughout the entire cycle. t_{RWD} , t_{AWD} and t_{CWD} define READ-MODIFY-WRITE cycles. Meeting these limits allows for reading and disabling output data and then applying input data. The values shown were calculated for reference allowing 10ns for the external latching of read data and application of write data. OE# held HIGH and WE# taken LOW after CAS# goes LOW result in a LATE WRITE (OE#-controlled) cycle. t_{WCS} , t_{RWD} , t_{CWD} and t_{AWD} are not applicable in a LATE WRITE cycle.
19. These parameters are referenced to CAS# leading edge in EARLY WRITE cycles and WE# leading edge in LATE WRITE or READ-MODIFY-WRITE cycles.
20. If OE# is tied permanently LOW, LATE WRITE or READ-MODIFY-WRITE operations are not possible.
21. A HIDDEN REFRESH may also be performed after a WRITE cycle. In this case, WE# = LOW and OE# = HIGH.
22. RAS#-ONLY REFRESH requires that all 8,192 rows of the MT4LC8M8E1 or all 4,096 rows of the MT4LC8M8B6 be refreshed at least once every 64ms. CBR REFRESH for either device requires that at least 4,096 cycles be completed every 64ms.
23. The DQs open during READ cycles once t_{OD} or t_{OFF} occurs. If CAS# goes HIGH before OE#, the DQs will open regardless of the state of OE#. If CAS# stays LOW while OE# is brought HIGH, the DQs will open. If OE# is brought back LOW (CAS# still LOW), the DQs will provide the previously read data.
24. LATE WRITE and READ-MODIFY-WRITE cycles must have both t_{OD} and t_{OE} met (OE# HIGH during WRITE cycle) in order to ensure that the output buffers will be open during the WRITE cycle. If OE# is taken back LOW while CAS# remains LOW, the DQs will remain open.
25. Column address changed once each cycle.
26. V_{IH} overshoot: V_{IH} (MAX) = $V_{CC} + 2V$ for a pulse width $\leq 10ns$, and the pulse width cannot be greater than one third of the cycle rate. V_{IL} undershoot: V_{IL} (MIN) = $-2V$ for a pulse width $\leq 10ns$, and the pulse width cannot be greater than one third of the cycle rate.

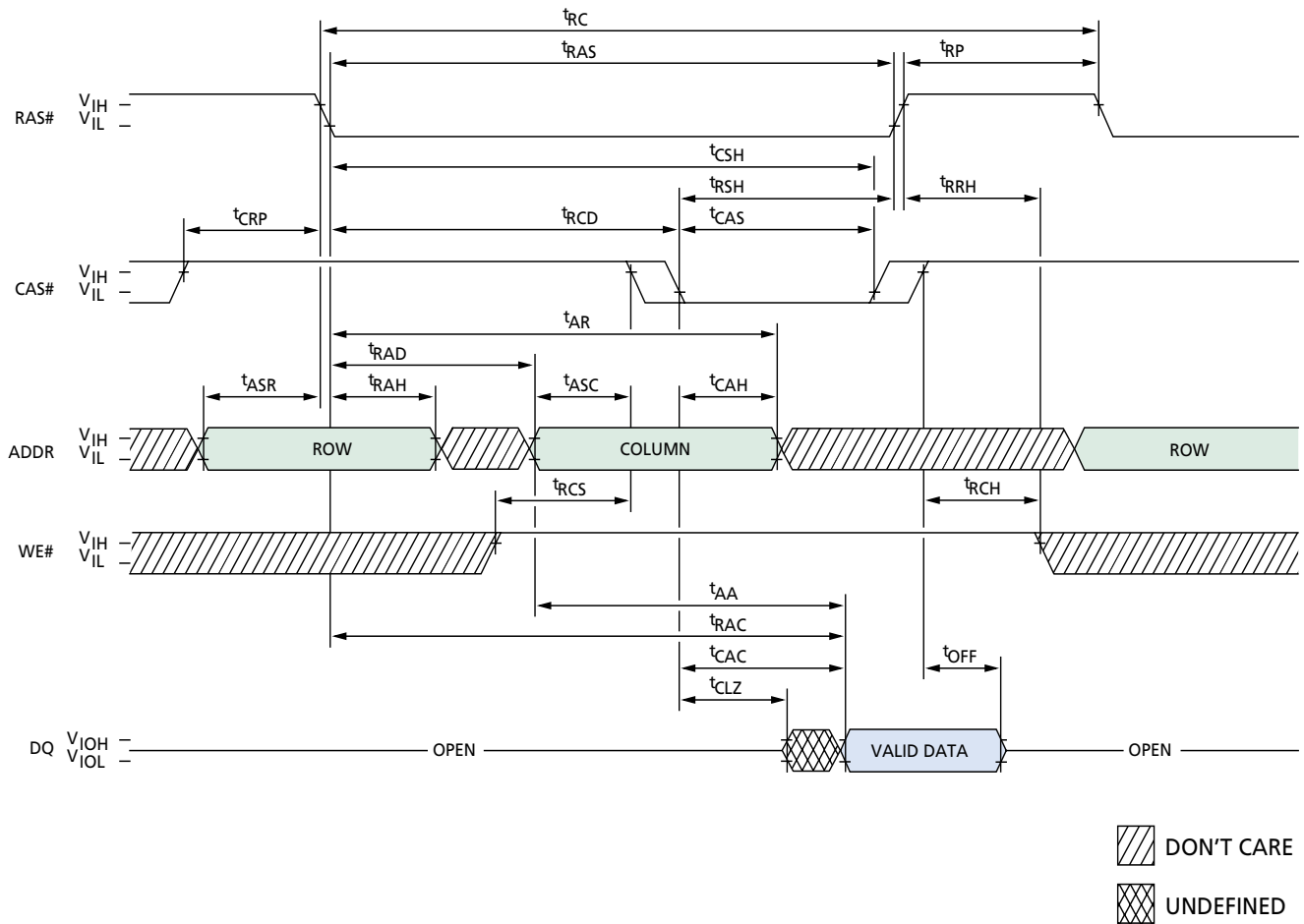
READ CYCLE

TIMING PARAMETERS

SYMBOL	-5		-6		UNITS
	MIN	MAX	MIN	MAX	
tAA		25		30	ns
tAR	40		45		ns
tASC	0		0		ns
tASR	0		0		ns
tCAC		13		15	ns
tCAH	8		10		ns
tCAS	13	10,000	15	10,000	ns
tCLZ	3		3		ns
tCRP	5		5		ns
tCSH	50		60		ns
tOD	3	13	3	15	ns
tOE		13		15	ns

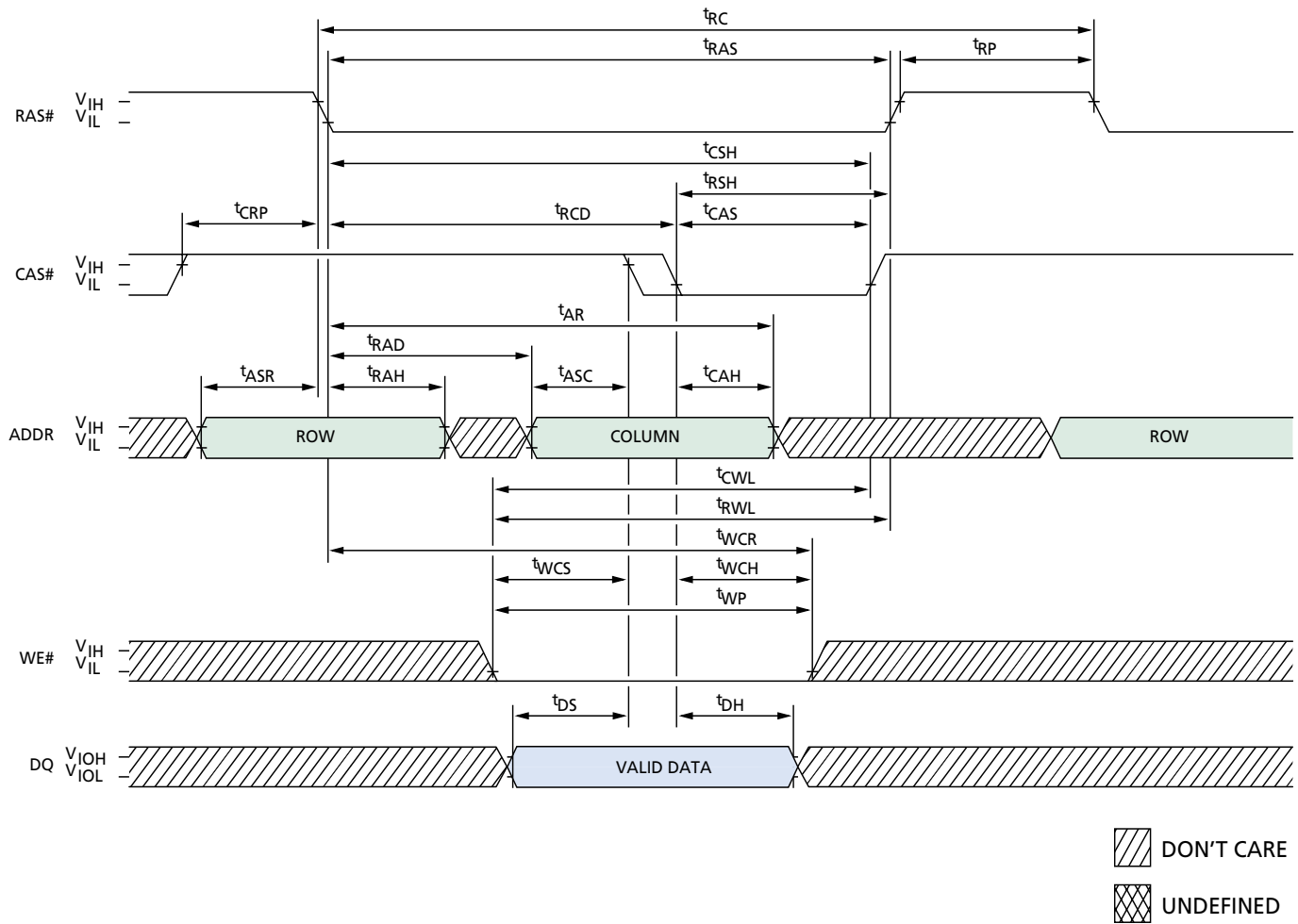
SYMBOL	-5		-6		UNITS
	MIN	MAX	MIN	MAX	
tOFF	3	13	3	15	ns
tRAC		50		60	ns
tRAD	13		15		ns
tRAH	8		10		ns
tRAS	50	10,000	60	10,000	ns
tRC	90		110		ns
tRCD	18		20		ns
tRCH	0		0		ns
tRCS	0		0		ns
tRP	30		40		ns
tRRH	0		0		ns
tRSH	13		15		ns

EARLY WRITE CYCLE

TIMING PARAMETERS

SYMBOL	-5		-6		UNITS
	MIN	MAX	MIN	MAX	
t_{AR}	40		45		ns
t_{ASC}	0		0		ns
t_{ASR}	0		0		ns
t_{CAH}	8		10		ns
t_{CAS}	13	10,000	15	10,000	ns
t_{CRP}	5		5		ns
t_{CSH}	50		60		ns
t_{CWL}	13		15		ns
t_{DH}	8		10		ns
t_{DS}	0		0		ns
t_{RAD}	13		15		ns

SYMBOL	-5		-6		UNITS
	MIN	MAX	MIN	MAX	
t_{RAH}	8		10		ns
t_{RAS}	50	10,000	60	10,000	ns
t_{RC}	90		110		ns
t_{RCD}	18		20		ns
t_{RP}	30		40		ns
t_{RSH}	13		15		ns
t_{RWL}	13		15		ns
t_{WCH}	8		10		ns
t_{WCR}	40		45		ns
t_{WCS}	0		0		ns
t_{WP}	8		10		ns

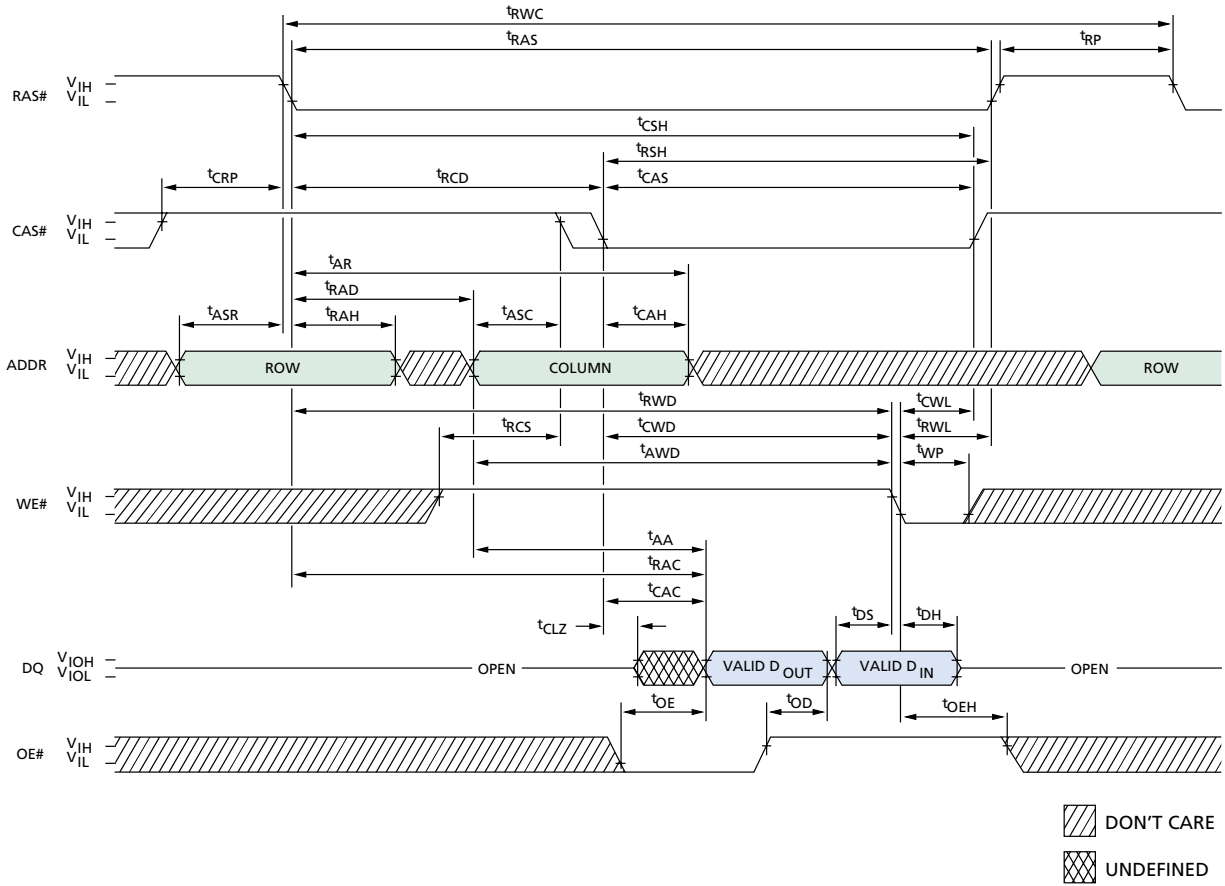
READ-WRITE CYCLE (LATE WRITE and READ-MODIFY-WRITE cycles)



TIMING PARAMETERS

SYMBOL	-5		-6		UNITS
	MIN	MAX	MIN	MAX	
tAA		25		30	ns
tAR	40		45		ns
tASC	0		0		ns
tASR	0		0		ns
tAWD	48		55		ns
tCAC		13		15	ns
tCAH	8		10		ns
tCAS	13	10,000	15	10,000	ns
tCLZ	3		3		ns
tCRP	5		5		ns
tCSH	50		60		ns
tCWD	36		40		ns
tCWL	13		15		ns
tDH	8		10		ns
tDS	0		0		ns

SYMBOL	-5		-6		UNITS
	MIN	MAX	MIN	MAX	
tOD	3	13	3	15	ns
tOE		13		15	ns
tOEH	13		15		ns
tRAC		50		60	ns
tRAD	13		15		ns
tRAH	8		10		ns
tRAS	50	10,000	60	10,000	ns
tRCD	18		20		ns
tRCS	0		0		ns
tRP	30		40		ns
tRSH	13		15		ns
tRWC	131		155		ns
tRWD	73		85		ns
tRWL	13		15		ns
tWP	8		10		ns

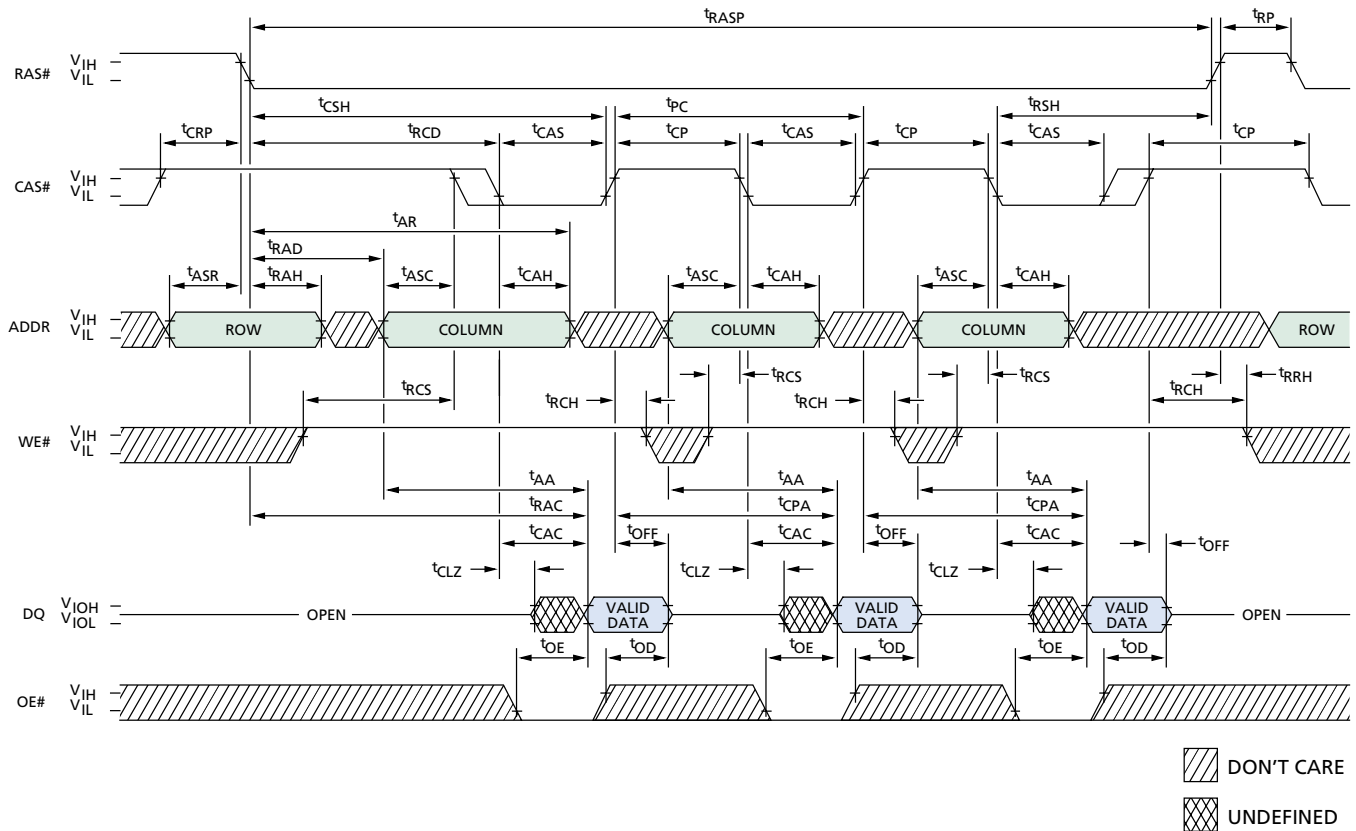
FAST-PAGE-MODE READ CYCLE

TIMING PARAMETERS

SYMBOL	-5		-6		UNITS
	MIN	MAX	MIN	MAX	
t_{AA}		25		30	ns
t_{AR}	40		45		ns
t_{ASC}	0		0		ns
t_{ASR}	0		0		ns
t_{CAC}		13		15	ns
t_{CAH}	8		10		ns
t_{CAS}	13	10,000	15	10,000	ns
t_{CLZ}	3		3		ns
t_{CP}	8		10		ns
t_{CPA}		30		35	ns
t_{CRP}	5		5		ns
t_{CSH}	50		60		ns
t_{OD}	3	13	3	15	ns

SYMBOL	-5		-6		UNITS
	MIN	MAX	MIN	MAX	
t_{OE}		13		15	ns
t_{OFF}	3	13	3	15	ns
t_{PC}	30		35		ns
t_{RAC}		50		60	ns
t_{RAD}	13		15		ns
t_{RAH}	8		10		ns
t_{RASP}	50	125,000	60	125,000	ns
t_{RCD}	18		20		ns
t_{RCH}	0		0		ns
t_{RCS}	0		0		ns
t_{RP}	30		40		ns
t_{RRH}	0		0		ns
t_{RSH}	13		15		ns

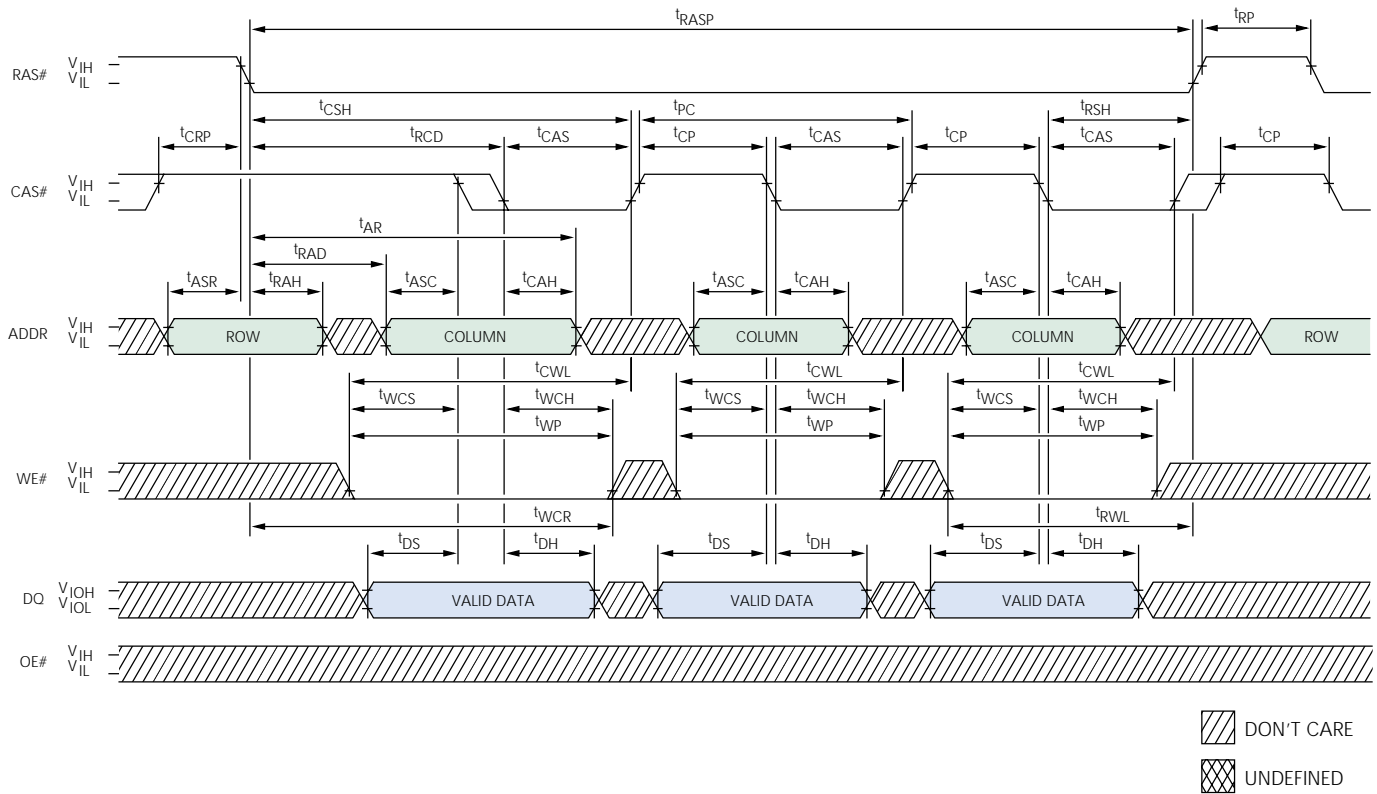
FAST-PAGE-MODE EARLY WRITE CYCLE



TIMING PARAMETERS

SYMBOL	-5		-6		UNITS
	MIN	MAX	MIN	MAX	
t_{AR}	40		45		ns
t_{ASC}	0		0		ns
t_{ASR}	0		0		ns
t_{CAH}	8		10		ns
t_{CAS}	13	10,000	15	10,000	ns
t_{CP}	8		10		ns
t_{CRP}	5		5		ns
t_{CSH}	50		60		ns
t_{CWL}	13		15		ns
t_{DH}	8		10		ns
t_{DS}	0		0		ns
t_{PC}	30		35		ns

SYMBOL	-5		-6		UNITS
	MIN	MAX	MIN	MAX	
t_{RAD}	13		15		ns
t_{RAH}	8		10		ns
t_{RASP}	50	125,000	60	125,000	ns
t_{RCD}	18		20		ns
t_{RP}	30		40		ns
t_{RSH}	13		15		ns
t_{RWL}	13		15		ns
t_{WCH}	8		10		ns
t_{WCR}	40		45		ns
t_{WCS}	0		0		ns
t_{WP}	8		10		ns

FAST-PAGE-MODE READ-WRITE CYCLE (LATE WRITE and READ-MODIFY-WRITE cycles)

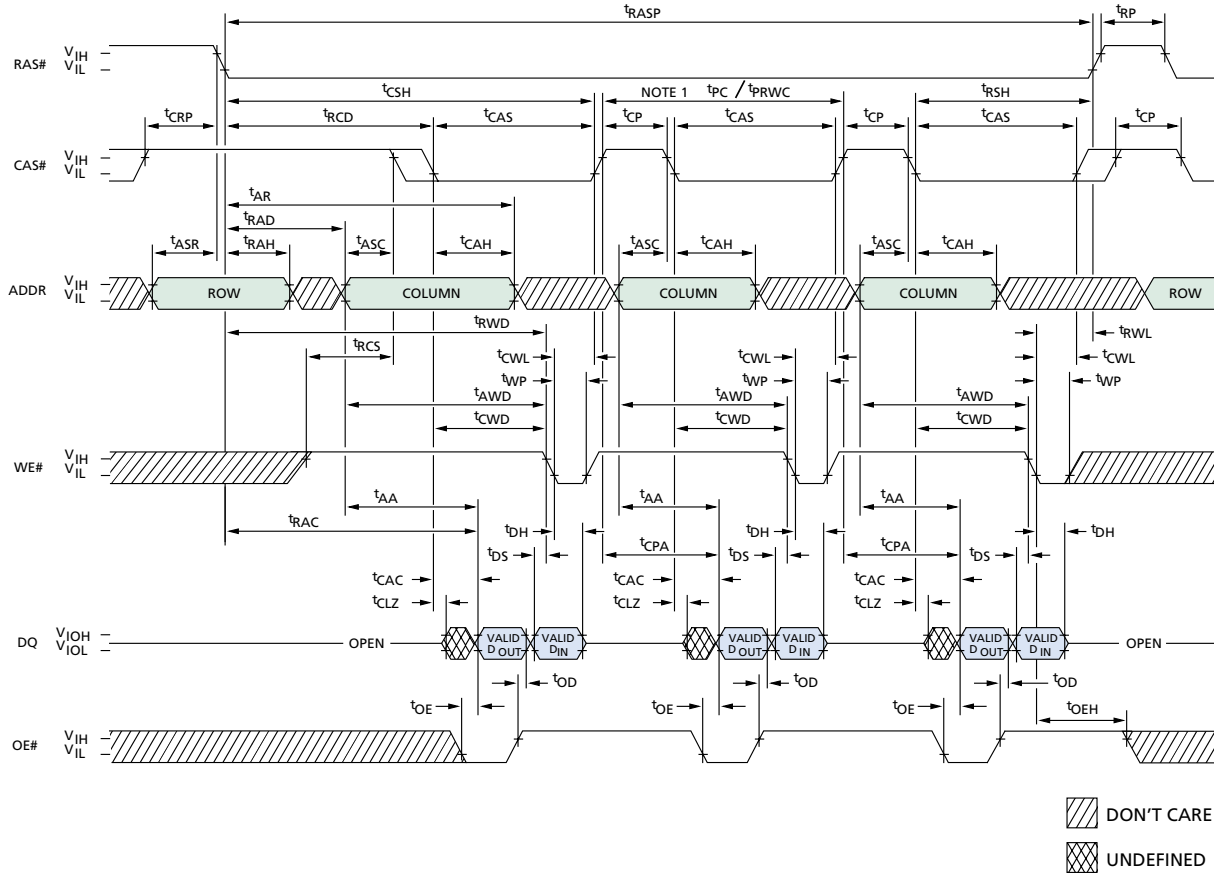

TIMING PARAMETERS

SYMBOL	-5		-6		UNITS
	MIN	MAX	MIN	MAX	
t _{AA}		25	30		ns
t _{AR}	40		45		ns
t _{ASC}	0		0		ns
t _{ASR}	0		0		ns
t _{AWD}	48		55		ns
t _{CAC}		13		15	ns
t _{CAH}	8		10		ns
t _{CAS}	13	10,000	15	10,000	ns
t _{CLZ}	3		3		ns
t _{CP}	8		10		ns
t _{CPA}		30		35	ns
t _{CRP}	5		5		ns
t _{CSH}	50		60		ns
t _{CWD}	36		40		ns
t _{CWL}	13		15		ns
t _{DH}	8		10		ns
t _{DS}	0		0		ns

SYMBOL	-5		-6		UNITS
	MIN	MAX	MIN	MAX	
t _{OD}	3	13	3	15	ns
t _{OE}		13		15	ns
t _{OEH}	13		15		ns
t _{PC}	30		35		ns
t _{PRWC}	76		85		ns
t _{RAC}		50		60	ns
t _{RAD}	13		15		ns
t _{RAH}	8		10		ns
t _{RASP}	50	125,000	60	125,000	ns
t _{RCD}	18		20		ns
t _{RCS}	0		0		ns
t _{RP}	30		40		ns
t _{RSH}	13		15		ns
t _{RWD}	73		85		ns
t _{RWL}	13		15		ns
t _{WP}	8		10		ns

NOTE: 1. t_{PC} is for LATE WRITE only.

FAST-PAGE-MODE READ EARLY WRITE CYCLE (Pseudo READ-MODIFY-WRITE)

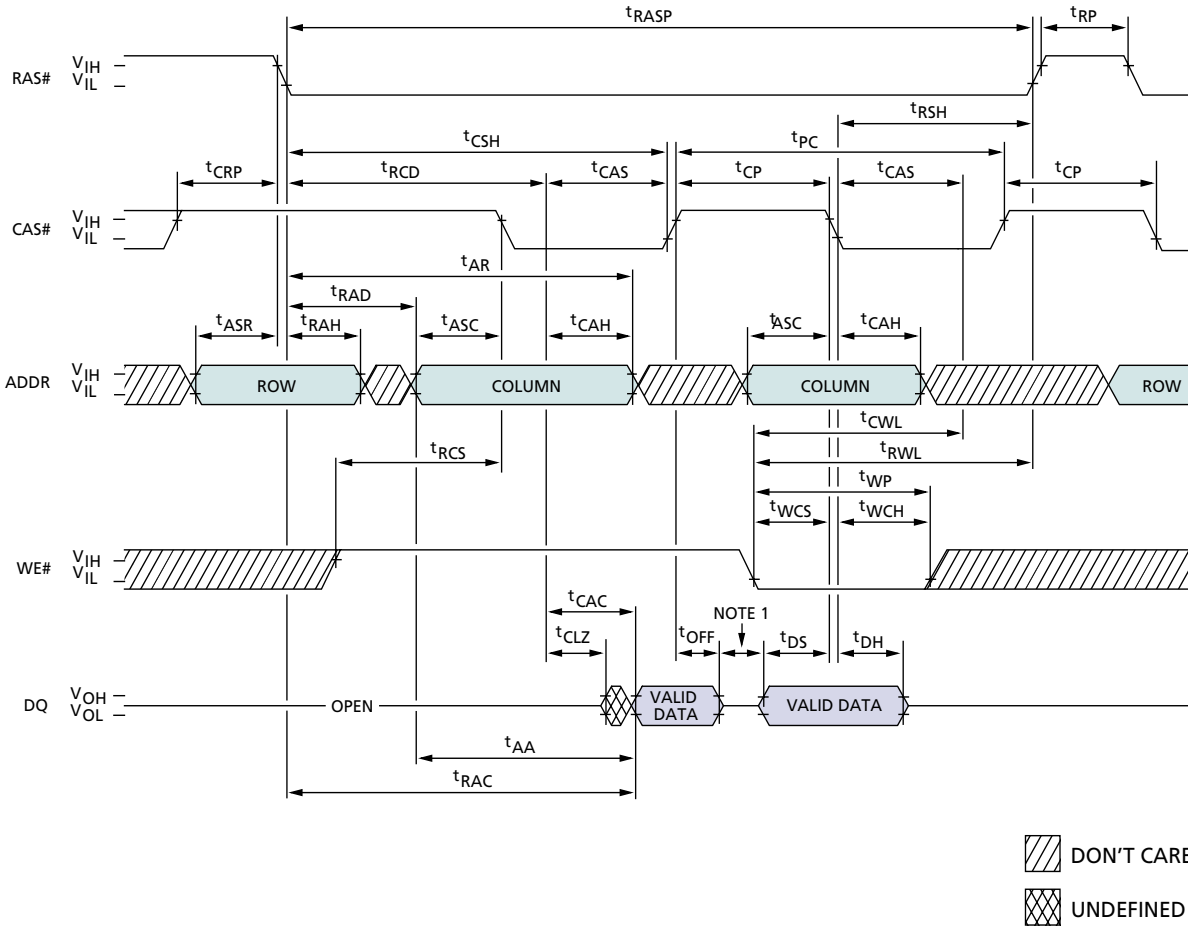

TIMING PARAMETERS

SYMBOL	-5		-6		UNITS
	MIN	MAX	MIN	MAX	
t_{AA}		25		30	ns
t_{AR}	40		45		ns
t_{ASC}	0		0		ns
t_{ASR}	0		0		ns
t_{CAC}		13		15	ns
t_{CAH}	8		10		ns
t_{CAS}	13	10,000	15	10,000	ns
t_{CLZ}	3		3		ns
t_{CP}	8		10		ns
t_{CRP}	5		5		ns
t_{CSH}	50		60		ns
t_{CWL}	13		15		ns
t_{DH}	8		10		ns
t_{DS}	0		0		ns

SYMBOL	-5		-6		UNITS
	MIN	MAX	MIN	MAX	
t_{OFF}	3	13	3	15	ns
t_{PC}	30		35		ns
t_{RAC}		50		60	ns
t_{RAD}	13		15		ns
t_{RAH}	8		10		ns
t_{RASP}	50	125,000	60	125,000	ns
t_{RCD}	18		20		ns
t_{RCS}	0		0		ns
t_{RP}	30		40		ns
t_{RSH}	13		15		ns
t_{RWL}	13		15		ns
t_{WCH}	8		10		ns
t_{WCS}	0		0		ns
t_{WP}	8		10		ns

NOTE: 1. Do not drive input data prior to output data going High-Z.

RAS#-ONLY REFRESH CYCLE (OE# and WE# = DON'T CARE)

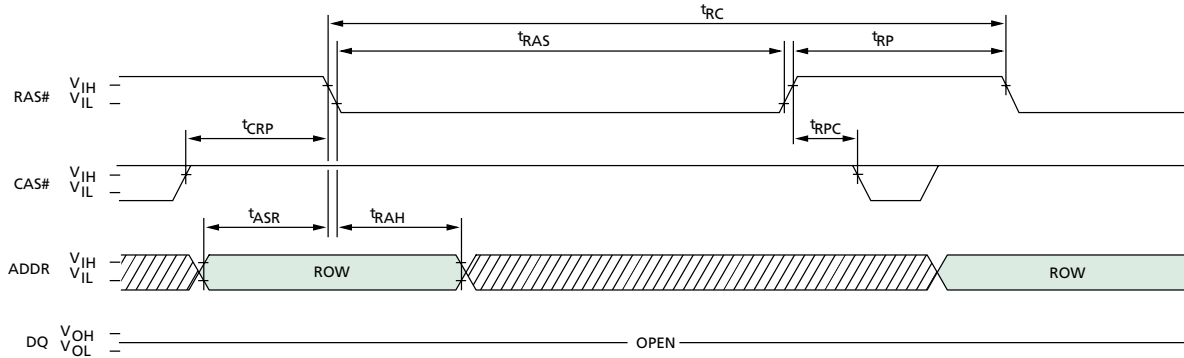

CBR REFRESH CYCLE (Addresses and OE# = DON'T CARE)

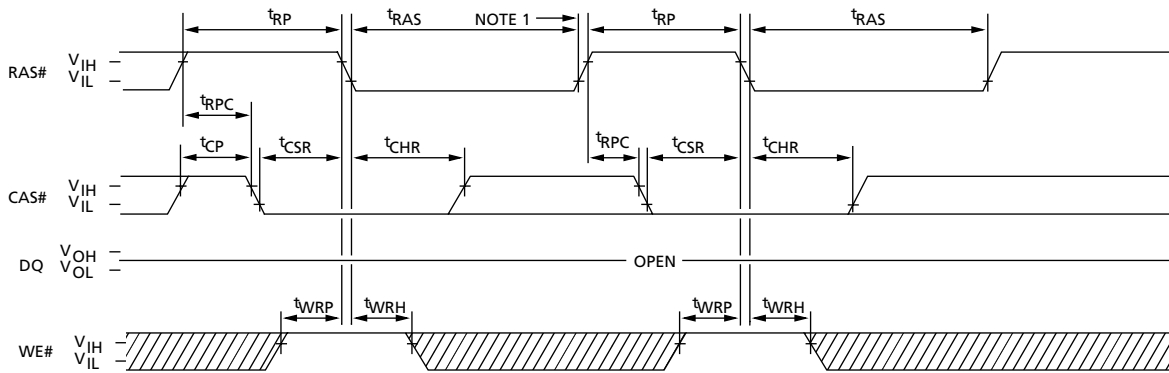

DON'T CARE

UNDEFINED

TIMING PARAMETERS

SYMBOL	-5		-6		UNITS
	MIN	MAX	MIN	MAX	
t_{ASR}	0		0		ns
t_{CHR}	15		15		ns
t_{CP}	8		10		ns
t_{CRP}	5		5		ns
t_{CSR}	5		5		ns
t_{RAH}	8		10		ns

SYMBOL	-5		-6		UNITS
	MIN	MAX	MIN	MAX	
t_{RAS}	50	10,000	60	10,000	ns
t_{RC}	90		110		ns
t_{RP}	30		40		ns
t_{RPC}	5		5		ns
t_{WRH}	10		10		ns
t_{WRP}	10		10		ns

NOTE: 1. End of CBR REFRESH cycle.

HIDDEN REFRESH CYCLE ¹ (WE# = HIGH; OE# = LOW)

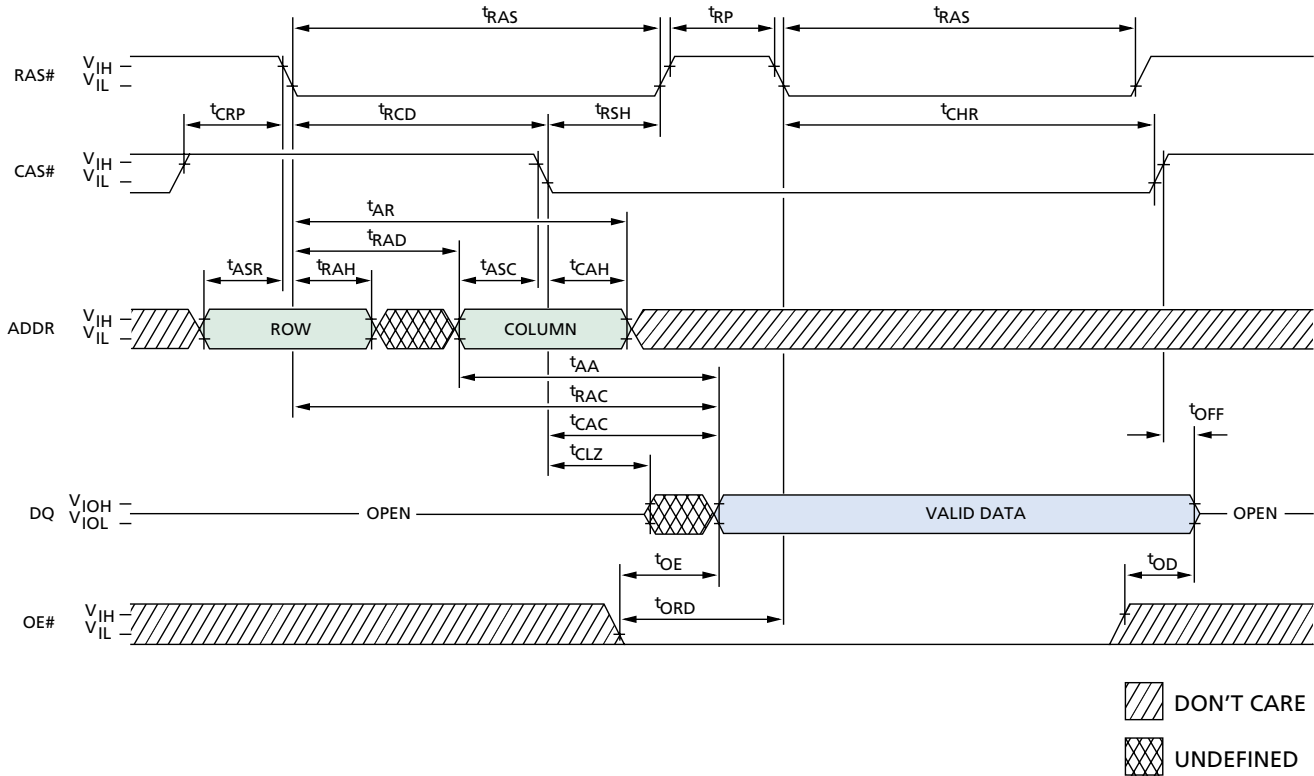

TIMING PARAMETERS

SYMBOL	-5		-6		UNITS
	MIN	MAX	MIN	MAX	
tAA		25		30	ns
tAR	40		45		ns
tASC	0		0		ns
tASR	0		0		ns
tCAC		13		15	ns
tCAH	8		10		ns
tCHR	15		15		ns
tCLZ	3		3		ns
tCRP	5		5		ns
tOD	3	13	3	15	ns

SYMBOL	-5		-6		UNITS
	MIN	MAX	MIN	MAX	
tOE		13		15	ns
tOFF	3	13	3	15	ns
tORD	0		0		ns
tRAC		50		60	ns
tRAD	13		15		ns
tRAH	8		10		ns
tRAS	50	10,000	60	10,000	ns
tRCD	18		20		ns
tRP	30		40		ns
tRSH	13		15		ns

NOTE: 1. A HIDDEN REFRESH may also be performed after a WRITE cycle. In this case, WE# = LOW and OE# = HIGH.

SELF REFRESH CYCLE (Addresses and OE# = DON'T CARE)

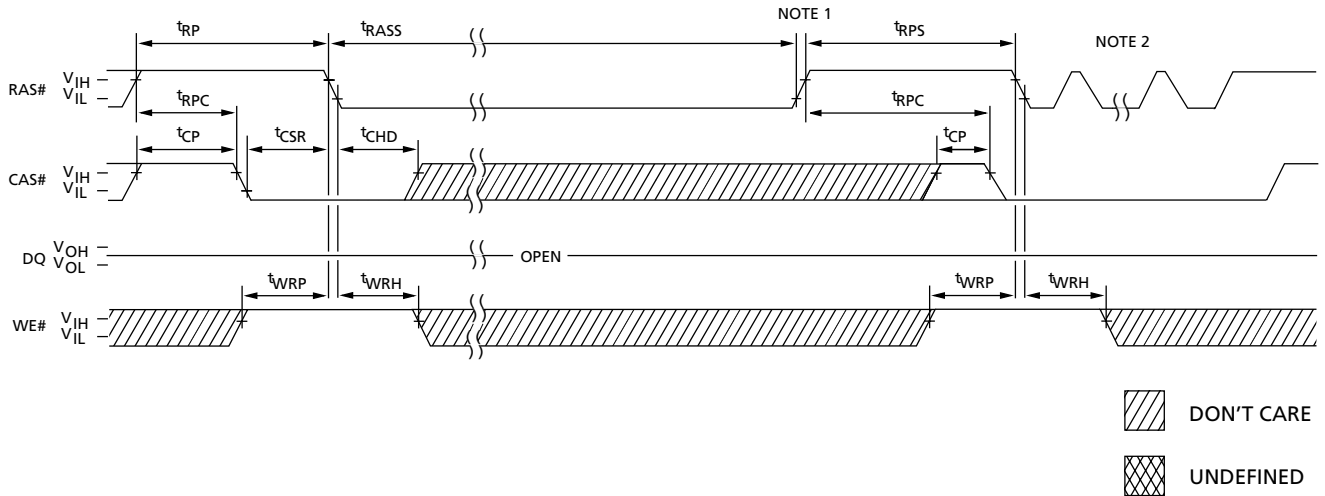

TIMING PARAMETERS

SYMBOL	-5		-6		UNITS
	MIN	MAX	MIN	MAX	
t_{CHD}	15		15		ns
t_{CP}	8		10		ns
t_{CSR}	5		5		ns
t_{RASS}	100		100		μ s
t_{RP}	30		40		ns

SYMBOL	-5		-6		UNITS
	MIN	MAX	MIN	MAX	
t_{RPC}	5		5		ns
t_{RPS}	90		105		ns
t_{WRH}	10		10		ns
t_{WRP}	10		10		ns

NOTE: 1. Once t_{RASS} (MIN) is met and RAS# remains LOW, the DRAM will enter self refresh mode.
 2. Once t_{RPS} is satisfied, a complete burst of all rows should be executed if RAS#-only or burst CBR is used.

32-PIN PLASTIC SOJ (400 mil)

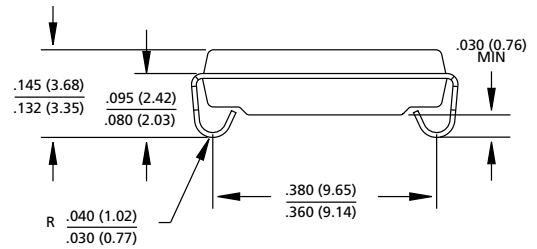
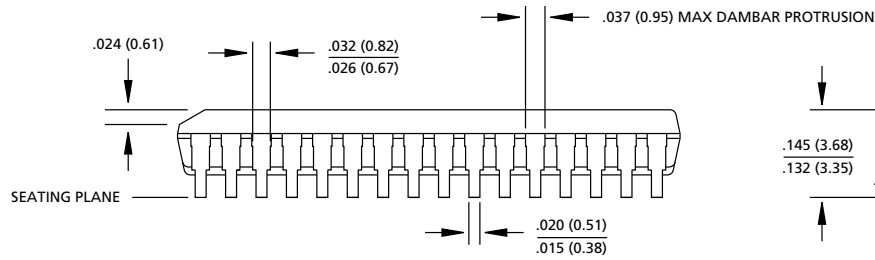
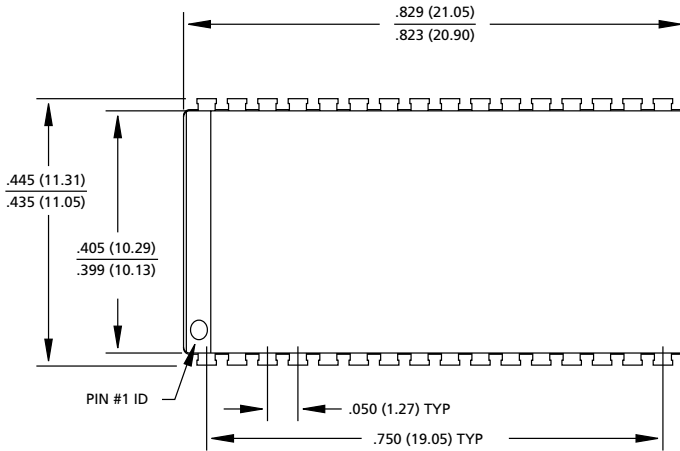

NOTE: 1. All dimensions in inches (millimeters) MAX or typical where noted.
MIN

2. Package width and length do not include mold protrusion; allowable mold protrusion is .01" per side.

32-PIN PLASTIC TSOP (400 mil)

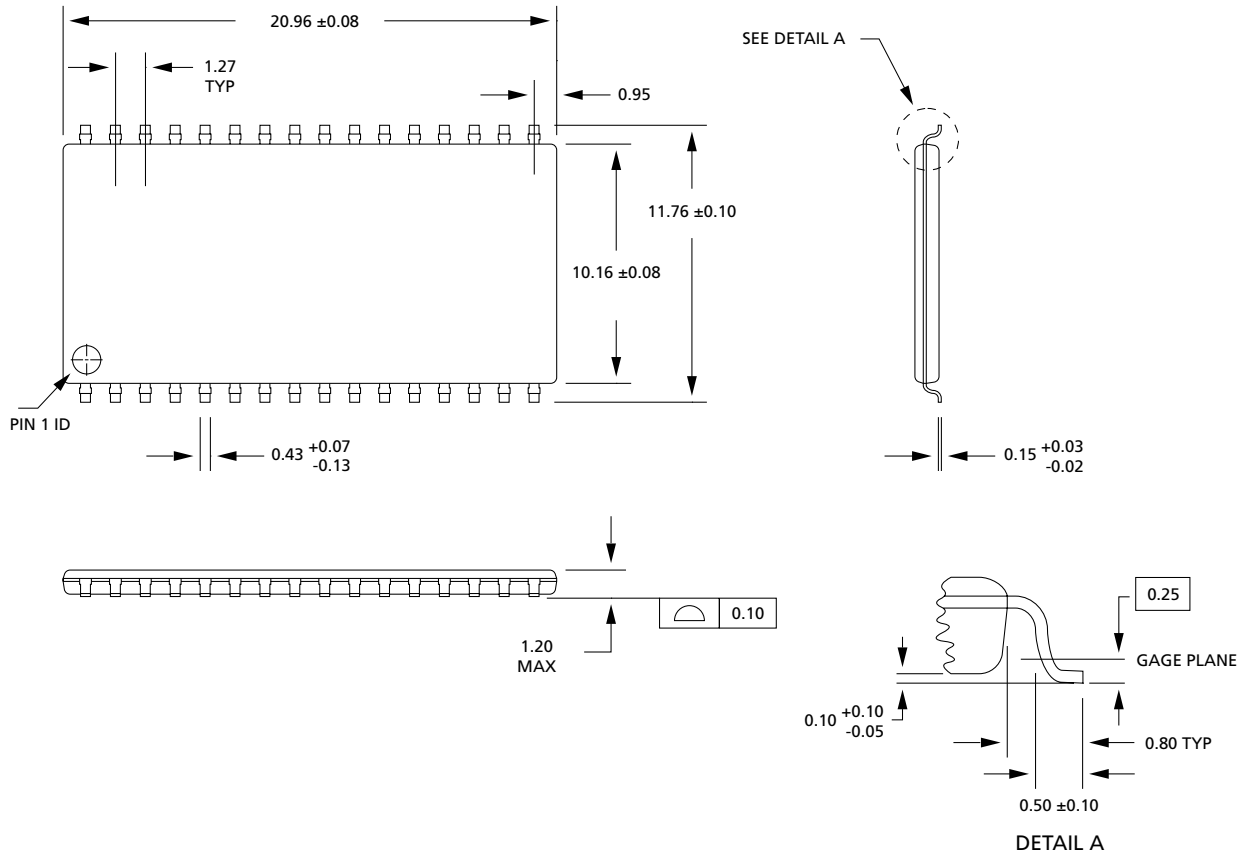

- NOTE:** 1. All dimensions in millimeters MAX or typical where noted.
MIN
2. Package width and length do not include mold protrusion; allowable mold protrusion is .25mm per side.



8000 S. Federal Way, P.O. Box 6, Boise, ID 83707-0006, Tel: 208-368-3900
 E-mail: prodmtg@micron.com, Internet: <http://www.micron.com>, Customer Comment Line: 800-932-4992
 Micron is a registered trademark of Micron Technology, Inc.