

Features

- **Wide Input Voltage from 4.3V to 14V**
- **Output Current up to 3A**
- **Adjustable Output Voltage from 0.8V to V_{IN}**
- $\pm 2\%$ System Accuracy
- **70mW Integrated Power MOSFET**
- **High Efficiency up to 92%**
- Automatic Skip/PWM Mode Operation
- **Current-Mode Operation**
- Easy Feedback Compensation
- Stable with Low ESR Output Capacitors
- Fast Load/Line Transient Response
- **Power-On-Reset Monitoring**
- **Fixed 500kHz Switching Frequency in PWM mode**
- **Built-in Digital Soft-Start**
- **Current-Limit Protection with Frequency Foldback**
- **Hiccup-Mode 50% Undervoltage Protection**
- **Over-Temperature Protection**
- **<3mA Quiescent Current in Shutdown Mode**
- **Small SOP-8 Package**
- **Lead Free and Green Devices Available**
(RoHS Compliant)

Applications

- **OLPC, UMPC**
- **Notebook Computer**
- **Handheld Portable Device**
- **Step-down Converters Requiring High Efficiency and 3A Output Current**

General Description

The APW7143 is a 3A asynchronous Buck converter with an integrated 70mΩ P-channel power MOSFET. The APW7143, designed with a current-mode control scheme, can convert wide input voltage of 4.3V to 14V to the output voltage adjustable from 0.8V to V_{IN} to provide excellent output voltage regulation.

For high efficiency over all load current range, the APW7143 is equipped with an automatic Skip/PWM mode operation. At light load, the IC operates in the Skip mode, which keeps a constant minimum inductor peak current, to reduce switching losses. At heavy load, the IC works in PWM mode, which inductor peak current is programmed by the COMP voltage, to provide high efficiency and excellent output voltage regulation.

The APW7143 is also equipped with power-on-reset, soft-start, and whole protections (undervoltage, over temperature, and current-limit) into a single package. In shutdown mode, the supply current drops below 3μA. This device, available in an 8-pin SOP-8 package, provides a very compact system solution with minimal external components and PCB area.

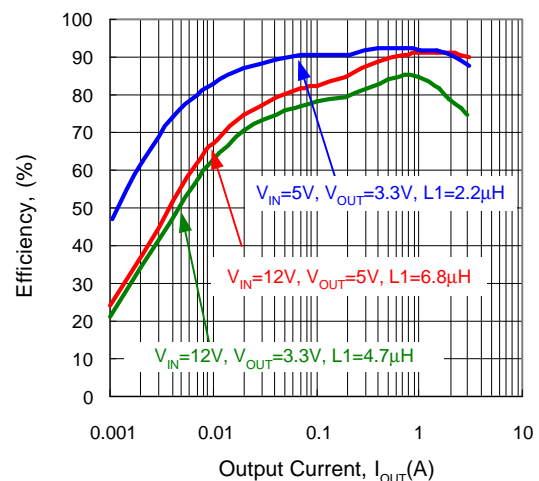

ANPEC reserves the right to make changes to improve reliability or manufacturability without notice, and advise customers to obtain the latest version of relevant information to verify before placing orders.

Ordering and Marking Information

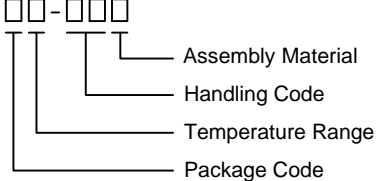
APW7143 □□-□□□ 	Package Code K : SOP-8 Operating Junction Temperature Range I : -40 to 85°C Handling Code TR : Tape & Reel Assembly Material L : Lead Free Device G : Halogen and Lead Free Device
APW7143 K : APW7143 XXXXX	XXXXX - Date Code

Note: ANPEC lead-free products contain molding compounds/die attach materials and 100% matte tin plate termination finish; which are fully compliant with RoHS. ANPEC lead-free products meet or exceed the lead-free requirements of IPC/JEDEC J-STD-020C for MSL classification at lead-free peak reflow temperature. ANPEC defines “Green” to mean lead-free (RoHS compliant) and halogen free (Br or Cl does not exceed 900ppm by weight in homogeneous material and total of Br and Cl does not exceed 1500ppm by weight).

Pin Configuration

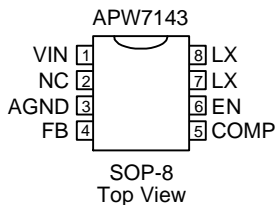

Pin 7 and 8 must be externally connected together.

Absolute Maximum Ratings (Note 2)

Symbol	Parameter	Rating	Unit
V_{IN}	VIN Supply Voltage (VIN to AGND)	-0.3 ~ 15	V
V_{LX}	LX to AGND Voltage	> 100ns	-1 ~ $V_{IN}+1$
		< 100ns	-5 ~ $V_{IN}+5$
	EN to AGND Voltage	-0.3 ~ $V_{IN}+0.3$	V
	FB, COMP to AGND Voltage	-0.3 ~ 6	V
	Maximum Junction Temperature	150	°C
T_{STG}	Storage Temperature	-65 ~ 150	°C
T_{SDR}	Maximum Lead Soldering Temperature, 10 Seconds	260	°C

Note 2 : Stresses above those listed in “Absolute Maximum Ratings” may cause permanent damage to the device.

Thermal Characteristics

Symbol	Parameter	Value	Unit
θ_{JA}	Junction-to-Ambient Thermal Resistance in Free Air ^(Note 3)	80	°C/W

Note 3: θ_{JA} is measured with the component mounted on a high effective thermal conductivity test board in free air.

Recommended Operating Conditions (Note 4)

Symbol	Parameter	Range	Unit
V_{IN}	VIN Supply Voltage	4.3 ~ 14	V
V_{OUT}	Converter Output Voltage	0.8 ~ V_{IN}	V
I_{OUT}	Converter Output Current	0 ~ 3	A
C_{IN}	Converter Input Capacitor (MLCC)	8 ~ 50	μ F
C_{OUT}	Converter Output Capacitor	20 ~ 1000	μ F
	Effective Series Resistance	0 ~ 60	m Ω
L_{OUT}	Converter Output Inductor	1 ~ 22	μ H
	Resistance of the Feedback Resistor connected from FB to AGND	1 ~ 20	k Ω
T_A	Ambient Temperature	-40 ~ 85	$^{\circ}$ C
T_J	Junction Temperature	-40 ~ 125	$^{\circ}$ C

Note 4: Refer to the Typical Application Circuits

Electrical Characteristics

Refer to the typical application circuits. These specifications apply over $V_{IN}=12V$, $V_{OUT}=3.3V$, and $T_A=-40 \sim 85^{\circ}C$, unless otherwise specified. Typical values are at $T_A=25^{\circ}C$.

Symbol	Parameter	Test Conditions	APW7143			Unit
			Min	Typ	Max	
SUPPLY CURRENT						
I_{VIN}	VIN Supply Current	$V_{FB} = V_{REF} + 50mV$, $V_{EN}=3V$, $LX=NC$	-	0.5	1.5	mA
I_{VIN_SD}	VIN Shutdown Supply Current	$V_{EN} = 0V$	-	-	3	μ A
POWER-ON-RESET (POR) VOLTAGE THRESHOLD						
	VIN POR Voltage Threshold	V_{IN} rising	3.9	4.1	4.3	V
	VIN POR Hysteresis		-	0.5	-	V
REFERENCE VOLTAGE						
V_{REF}	Reference Voltage	Regulated on FB pin	-	0.8	-	V
	Output Voltage Accuracy	$T_J = 25^{\circ}C$, $I_{OUT}=10mA$, $V_{IN}=12V$	-1.0	-	+1.0	%
		$I_{OUT}=10mA \sim 3A$, $V_{IN}=4.75 \sim 14V$	-2.0	-	+2.0	
	Line Regulation	$V_{IN} = 4.75V$ to $14V$	-	+0.02	-	%/V
	Load Regulation	$I_{OUT} = 0.5A \sim 3A$	-	-0.04	-	%/A
OSCILLATOR AND DUTY CYCLE						
F_{OSC}	Oscillator Frequency	$T_J = -40 \sim 125^{\circ}C$, $V_{IN} = 4.75 \sim 14V$	450	500	550	kHz
	Foldback Frequency	$V_{OUT} = 0V$	-	80	-	kHz
	Maximum Converter's Duty		-	99	-	%
T_{ON_MIN}	Minimum Pulse Width of LX		-	150	-	ns
CURRENT-MODE PWM CONVERTER						
Gm	Error Amplifier Transconductance	$V_{FB}=V_{REF}\pm 50mV$	-	200	-	μ A/V
	Error Amplifier DC Gain	COMP = NC	-	80	-	dB

Electrical Characteristics (Cont.)

Refer to the typical application circuits. These specifications apply over $V_{IN}=12V$, $V_{OUT}=3.3V$, and $T_A=-40 \sim 85^\circ C$, unless otherwise specified. Typical values are at $T_A=25^\circ C$.

Symbol	Parameter	Test Conditions	APW7143			Unit
			Min	Typ	Max	
	Current-Sense to COMP Voltage Transresistance		-	0.06	-	V/A
	P-Channel Switch Resistance	$V_{IN} = 5V, T_J = 25^\circ C$	-	90	110	m Ω
		$V_{IN} = 12V, T_J = 25^\circ C$	-	70	90	
PROTECTIONS						
I_{LIM}	P-Channel Switch Current-limit	Peak Current	5.0	6.5	8.0	A
V_{TH_UV}	FB Under-Voltage Threshold	V_{FB} falling	45	50	55	%
	FB Under-Voltage Debounce		-	1	-	μs
T_{OTP}	Over-Temperature Trip Point		-	150	-	$^\circ C$
	Over-Temperature Hysteresis		-	40	-	$^\circ C$
SOFT-START, SOFTSTOP, ENABLE AND INPUT CURRENTS						
T_{SS}	Soft-Start		1.5	2	2.5	ms
	LX Pull-Low Switch Resistance	Switch is turned on for 2 ms (typ.) interval from the falling edge of enable signal.	-	10	-	Ω
	EN Shutdown Voltage Threshold	V_{EN} falling	0.5	-	-	V
	EN Enable Voltage Threshold		-	-	2.1	V
	P-Channel Switch Leakage Current	$V_{EN} = 0V, V_{LX} = 0V$	-	-	2	μA
I_{FB}	FB Pin Input Current		-100	-	+100	nA
I_{EN}	EN Pin Input Current	$V_{EN} = 0V \sim V_{IN}$	-100	-	+100	nA

Typical Operating Characteristics

(Refer to the application circuit 1 in the section "Typical Application Circuits", $V_{IN}=12V$, $V_{OUT}=3.3V$, $L1=4.7\mu H$)

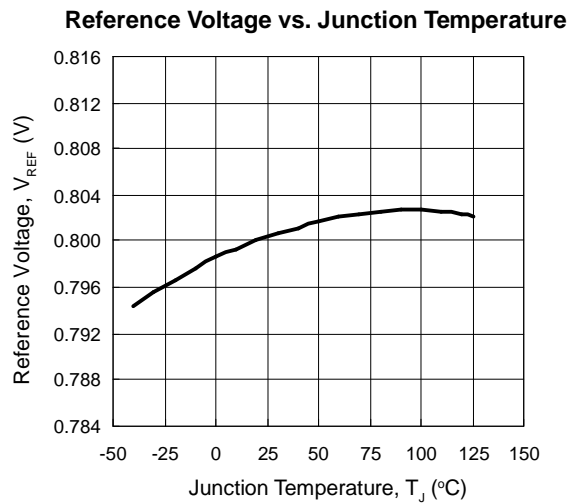
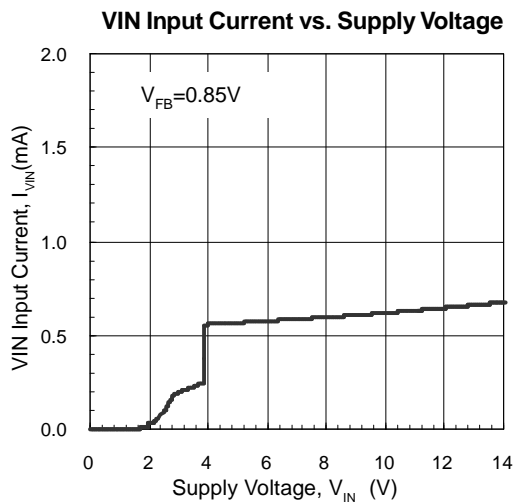
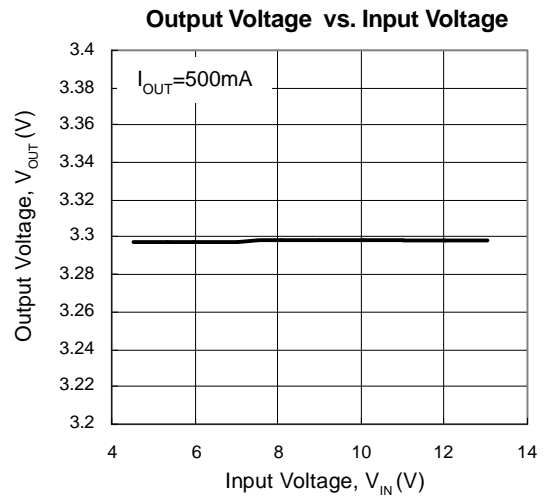
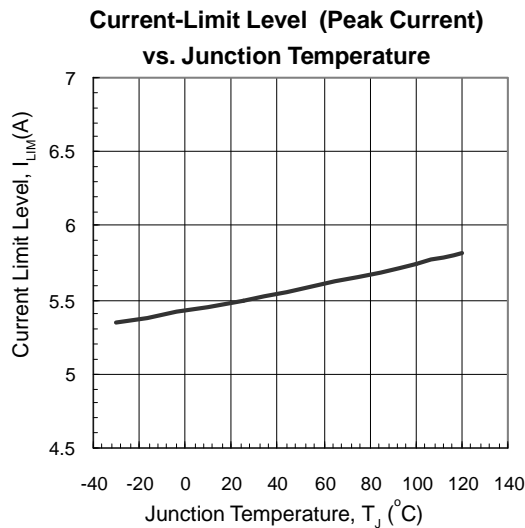
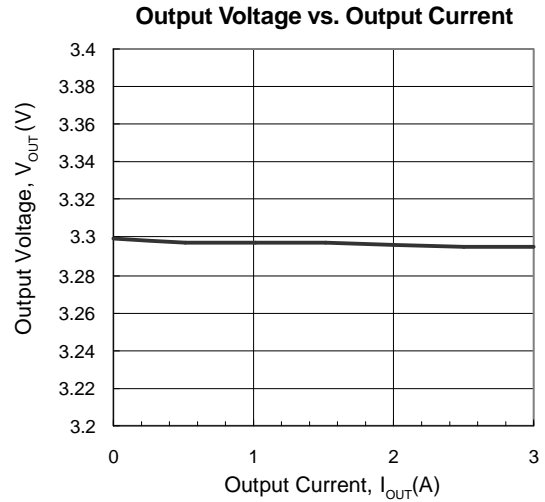
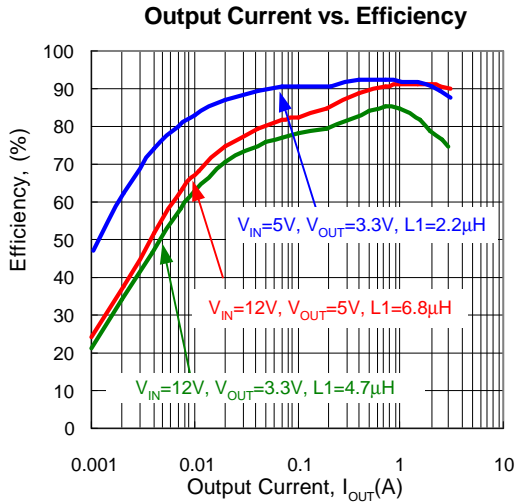

Typical Operating Characteristics (Cont.)

(Refer to the application circuit 1 in the section "Typical Application Circuits", $V_{IN}=12V$, $V_{OUT}=3.3V$, $L1=4.7\mu H$)

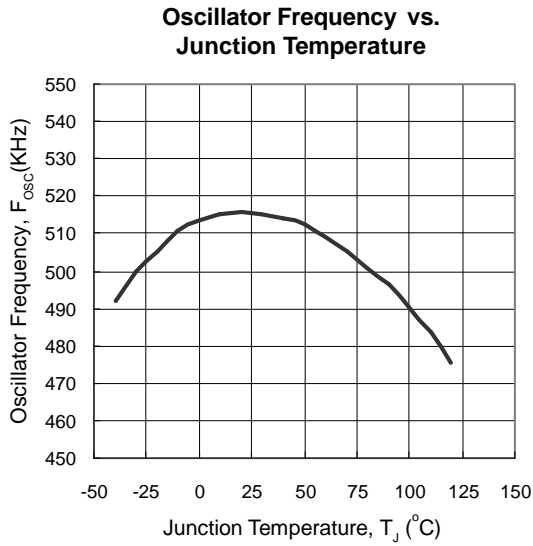

Operating Waveforms

(Refer to the application circuit 1 in the section "Typical Application Circuits", $V_{IN}=12V$, $V_{OUT}=3.3V$, $L1=4.7\mu H$)

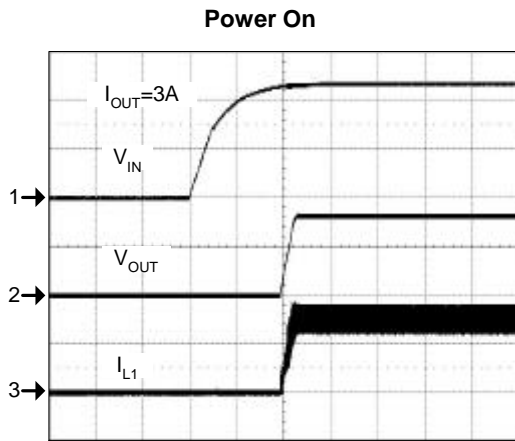

CH1 : V_{IN} , 5V/div
 CH2 : V_{OUT} , 2V/div
 CH3 : I_{L1} , 2A/div
 Time : 5ms/div

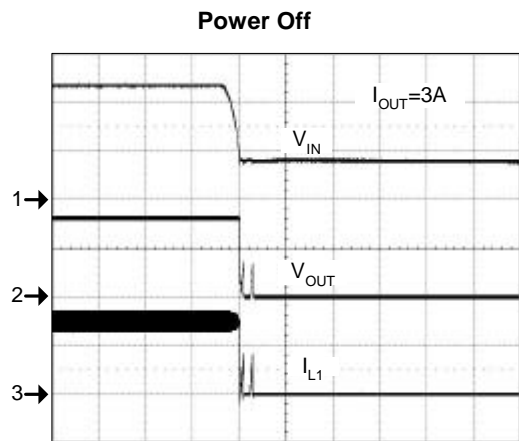

CH1 : V_{IN} , 5V/div
 CH2 : V_{OUT} , 2V/div
 CH3 : I_{L1} , 2A/div
 Time : 10ms/div

Operating Waveforms (Cont.)

(Refer to the application circuit 1 in the section "Typical Application Circuits", $V_{IN}=12V$, $V_{OUT}=3.3V$, $L1=4.7\mu H$)

Enable

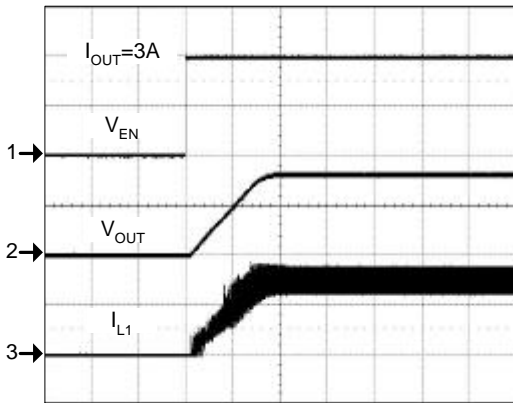

CH1 : V_{EN} , 5V/div
 CH2 : V_{OUT} , 2V/div
 CH3 : I_{L1} , 2A/div
 Time : 1ms/div

Shutdown

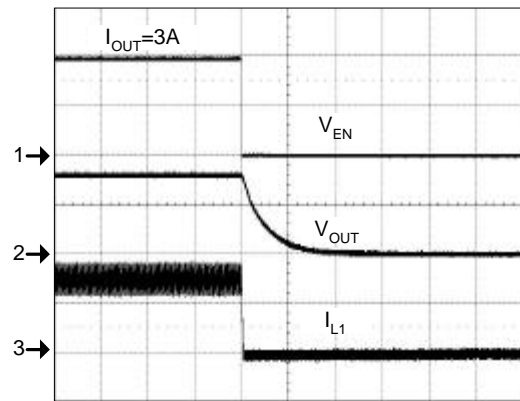

CH1 : V_{EN} , 5V/div
 CH2 : V_{OUT} , 2V/div
 CH3 : I_{L1} , 2A/div
 Time : 100 μ s/div

Over Current

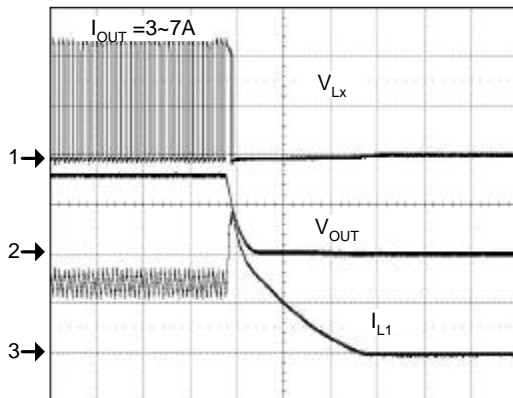

CH1 : V_{LX} , 10V/div
 CH2 : V_{OUT} , 2V/div
 CH3 : I_{L1} , 5A/div
 Time : 20 μ s/div

Short Circuit

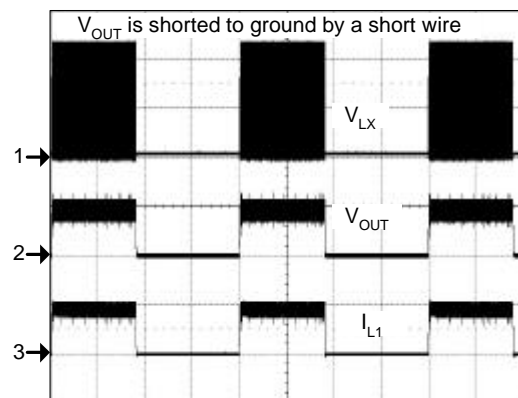

CH1 : V_{LX} , 5V/div
 CH2 : V_{OUT} , 200mV/div
 CH3 : I_{L1} , 5A/div
 Time : 5ms/div

Operating Waveforms (Cont.)

(Refer to the application circuit 1 in the section "Typical Application Circuits", $V_{IN}=12V$, $V_{OUT}=3.3V$, $L1=4.7\mu H$)

Load Transient Response

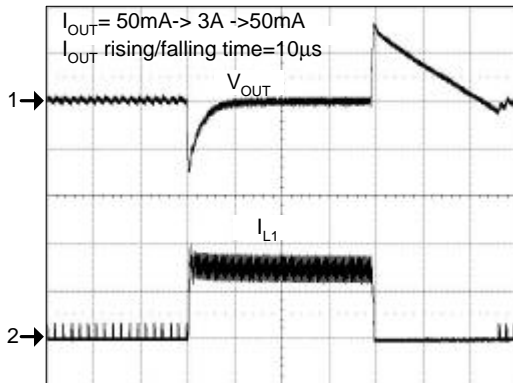

CH1 : V_{OUT} , 200mV/div
 CH2 : I_{L1} , 2A/div
 Time : $100\mu s/div$

Load Transient Response



CH1 : V_{OUT} , 100mV/div
 CH2 : I_{L1} , 2A/div
 Time : $100\mu s/div$

Switching Waveform

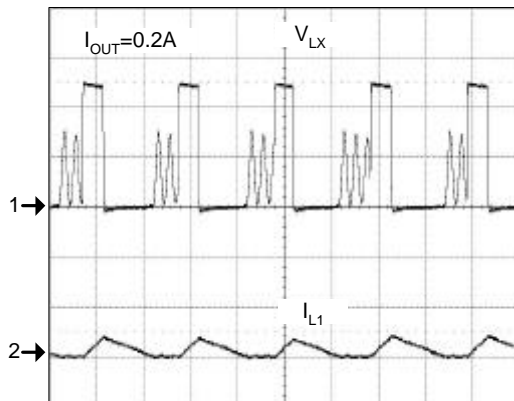

CH1 : V_{LX} , 5V/div
 CH2 : I_{L1} , 2A/div
 Time : $1\mu s/div$

Switching Waveform

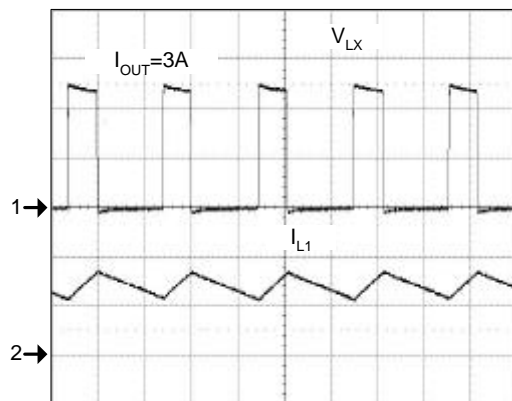

CH1 : V_{LX} , 5V/div
 CH2 : I_{L1} , 2A/div
 Time : $1\mu s/div$

Operating Waveforms (Cont.)

(Refer to the application circuit 1 in the section “Typical Application Circuits”, $V_{IN}=12V$, $V_{OUT}=3.3V$, $L1=4.7\mu H$)

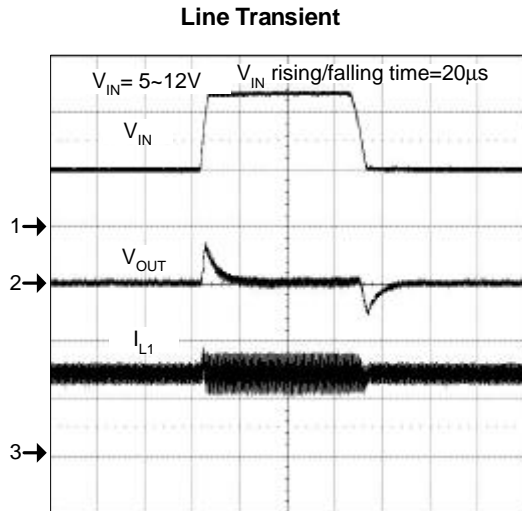

CH1 : V_{IN} , 5V/div
 CH2 : V_{OUT} , 50mV/div (Voffset=3.3V)
 CH3 : I_{L1} , 2A/div
 Time : 100µs/div

Pin Description

PIN No.	NAME	FUNCTION
1	VIN	Power Input. VIN supplies the power (4.3V to 14V) to the control circuitry, gate driver, and step-down converter switch. Connecting a ceramic bypass capacitor and a suitably large capacitor between VIN and AGND eliminates switching noise and voltage ripple on the input to the IC.
2	NC	No Connection.
3	AGND	Ground of MOSFET Gate Driver and Control Circuitry.
4	FB	Output feedback Input. The APW7143 senses the feedback voltage via FB and regulates the voltage at 0.8V. Connecting FB with a resistor-divider from the converter's output sets the output voltage from 0.8V to VIN.
5	COMP	Output of the error amplifier. Connect a series RC network from COMP to AGND to compensate the regulation control loop. In some cases, an additional capacitor from COMP to AGND is required.
6	EN	Enable Input. EN is a digital input that turns the regulator on or off. Drive EN high to turn on the regulator, drive it low to turn it off. Connect this pin to VIN if it is not used.
7, 8	LX	Power Switching Output. LX is the Drain of the P-Channel power MOSFET to supply power to the output LC filter.

Block Diagram

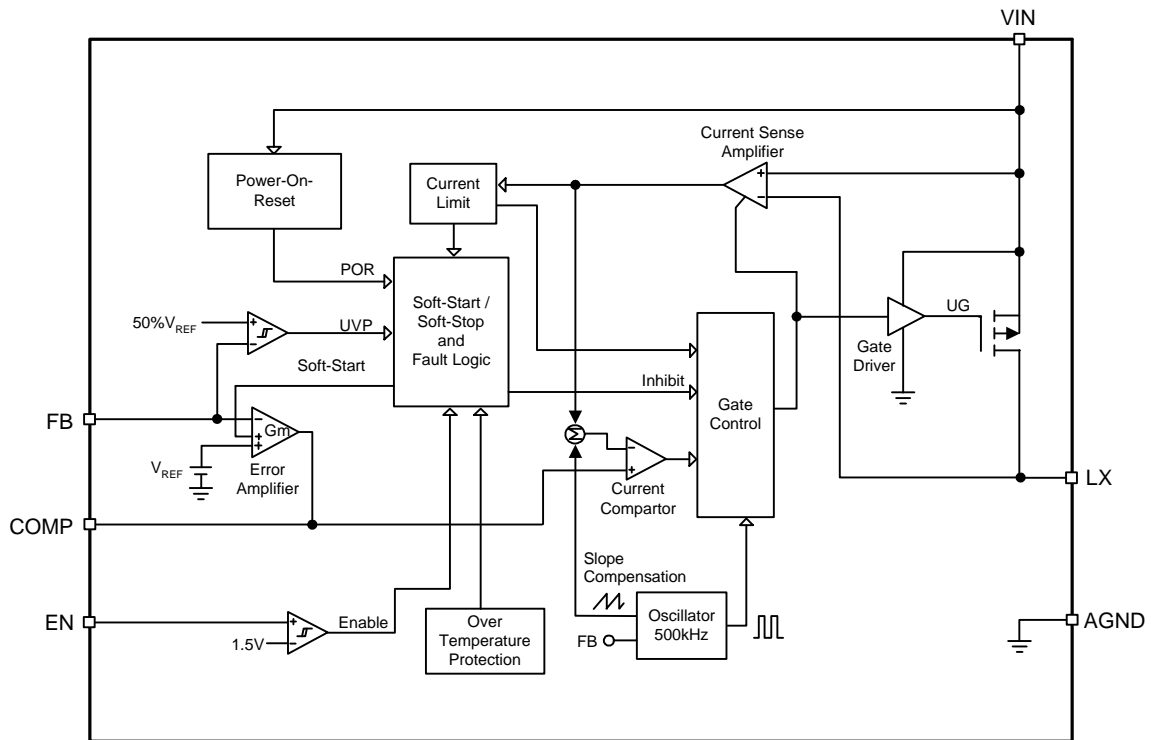

Typical Application Circuits

1. +12V Single Power Input Step-down Converter (with an Electrolytic Output Capacitor)

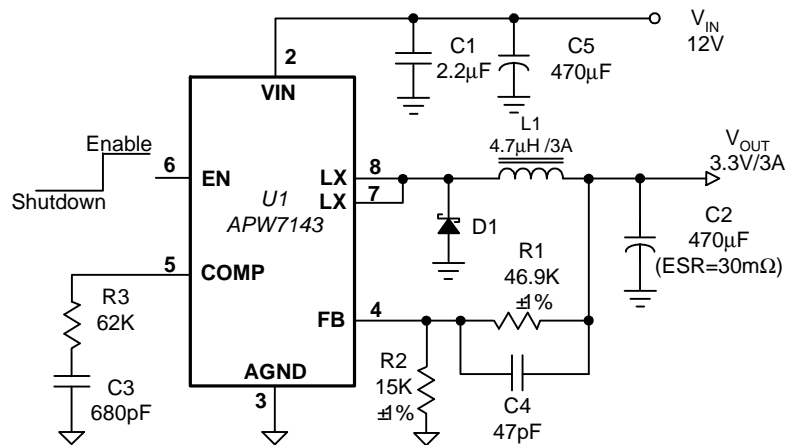

Typical Application Circuits (Cont.)

2. 4.3-14V Single Power Input Step-down Converter(with ceramic Input/Output Capacitor)

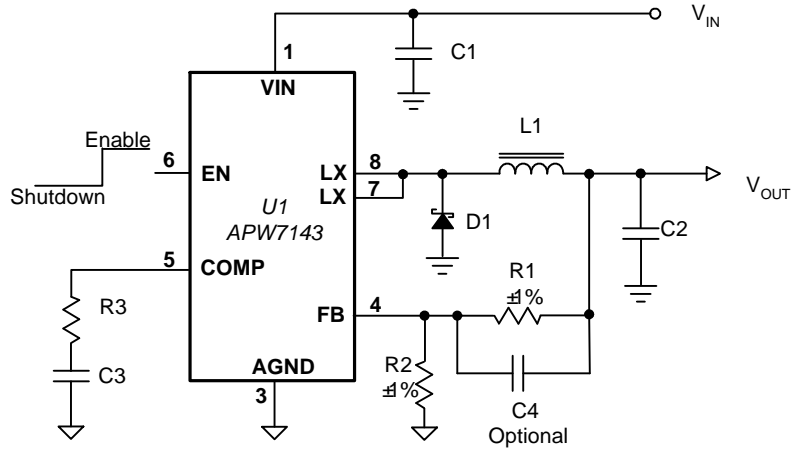

a. Cost-effective Feedback Compensation (C4 is not connected)

V _{IN} (V)	V _{OUT} (V)	L1(mH)	C2(mF)	C2 ESR(mW)	R1(kW)	R2(kW)	R3(kW)	C3(pF)
12	5	6.8	22	5	63.0	12	10.0	1500
12	5	6.8	44	3	63.0	12	20.0	1500
12	3.3	4.7	22	5	46.9	15	10.0	1500
12	3.3	4.7	44	3	46.9	15	22.0	1500
12	2	3.3	22	5	30.0	20	10.0	1500
12	2	3.3	44	3	30.0	20	20.0	1500
12	1.2	2.2	22	5	7.5	15	8.2	1800
12	1.2	2.2	44	3	7.5	15	16.0	1800
5	3.3	2.2	22	5	46.9	15	8.2	680
5	3.3	2.2	44	3	46.9	15	20.0	680
5	1.2	2.2	22	5	7.5	15	3.0	1800
5	1.2	2.2	44	3	7.5	15	7.5	1800

b. Fast-Transient-Response Feedback Compensation (C4 is connected)

V _{IN} (V)	V _{OUT} (V)	L1(mH)	C2(mF)	C2 ESR(mW)	R1(kW)	R2(kW)	C4(pF)	R3(kW)	C3(pF)
12	5	6.8	22	5	63.0	12	47	33.0	470
12	5	6.8	44	3	63.0	12	47	68.0	470
12	3.3	4.7	22	5	46.9	15	47	22.0	680
12	3.3	4.7	44	3	46.9	15	47	47.0	680
12	2	3.3	22	5	30.0	20	47	13.0	1200
12	2	3.3	44	3	30.0	20	47	27.0	1200
12	1.2	2.2	22	5	7.5	15	150	7.5	2200
12	1.2	2.2	44	3	7.5	15	150	15.0	2200
5	3.3	2.2	22	5	46.9	15	56	20.0	220
5	3.3	2.2	44	3	46.9	15	56	43.0	220
5	1.2	2.2	22	5	7.5	15	330	3.3	1800
5	1.2	2.2	44	3	7.5	15	330	8.2	1500

Function Description

VIN Power-On-Reset (POR)

The APW7143 keeps monitoring the voltage on VIN pin to prevent wrong logic operations which may occur when VIN voltage is not high enough for the internal control circuitry to operate. The VIN POR has a rising threshold of 4.1V (typical) with 0.5V of hysteresis.

During start-up, the VIN voltage must exceed the enable voltage threshold. Then the IC starts a start-up process and ramps up the output voltage to the voltage target.

Digital Soft-Start

The APW7143 has a built-in digital soft-start to control the rise rate of the output voltage and limit the input current surge during start-up. During soft-start, an internal voltage ramp (V_{RAMP}), connected to one of the positive inputs of the error amplifier, rises up from 0V to 0.95V to replace the reference voltage (0.8V) until the voltage ramp reaches the reference voltage.

Output Undervoltage Protection (UVP)

In the process of operation, if a short-circuit occurs, the output voltage will drop quickly. Before the current-limit circuit responds, the output voltage will fall out of the required regulation range. The undervoltage continually monitors the FB voltage after soft-start is completed. If a load step is strong enough to pull the output voltage lower than the undervoltage threshold, the IC shuts down converter's output.

The undervoltage threshold is 50% of the nominal output voltage. The undervoltage comparator has a built-in 2 μ s noise filter to prevent the chips from wrong UVP shutdown caused by noise. The undervoltage protection works in a hiccup mode without latched shutdown. The IC will initiate a new soft-start process at the end of the preceding delay.

Over-Temperature Protection (OTP)

The over-temperature circuit limits the junction temperature of the APW7143. When the junction temperature exceeds $T_j = +150^\circ\text{C}$, a thermal sensor turns off the power MOSFET, allowing the devices to cool. The thermal sensor allows the converters to start a start-up process and regulate the output voltage again after the junction temperature cools by 40 $^\circ\text{C}$. The OTP is designed with a 40 $^\circ\text{C}$ hysteresis to lower the average T_j during continuous ther-

mal overload conditions, increasing lifetime of the APW7143.

Enable/Shutdown

Driving EN to ground places the APW7143 in shutdown. When in shutdown, the internal P-Channel power MOSFET turns off, all internal circuitry shuts down and the quiescent supply current reduces to less than 3 μA .

Current-Limit Protection

The APW7143 monitors the output current, flows through the P-Channel power MOSFET, and limits the current peak at current-limit level to prevent loads and the IC from damages during overload or short-circuit conditions.

Frequency Foldback

The foldback frequency is controlled by the FB voltage. When the output is shorted to ground, the frequency of the oscillator will be reduced to about 80kHz. This lower frequency allows the inductor current to discharge safely and thereby prevent current runaway. The oscillator's frequency will gradually increase to its designed rate when the feedback voltage on FB again approaches 0.8V.

Application Information

Setting Output Voltage

The regulated output voltage is determined by:

$$V_{OUT} = 0.8 \cdot \left(1 + \frac{R1}{R2}\right) \quad (V)$$

Suggested R2 is in the range from 1K to 20kΩ. For portable applications, a 10kΩ resistor is suggested for R2. To prevent stray pickup, locate resistors R1 and R2 close to APW7143.

Input Capacitor Selection

Each time, when the P-channel power MOSFET (Q1) turns on, small ceramic capacitors for high frequency decoupling and bulk capacitors are required to supply the surge current. The small ceramic capacitors have to be placed physically close to the VIN and between the VIN and the anode of the Schottky diode (D1).

The important parameters for the bulk input capacitor are the voltage rating and the RMS current rating. For reliable operation, select the bulk capacitor with voltage and current ratings above the maximum input voltage and largest RMS current required by the circuit. The capacitor voltage rating should be at least 1.25 times greater than the maximum input voltage and a voltage rating of 1.5 times is a conservative guideline. The RMS current (I_{RMS}) of the bulk input capacitor is calculated as the following equation:

$$I_{RMS} = I_{OUT} \cdot \sqrt{D \cdot (1-D)} \quad (A)$$

where D is the duty cycle of the power MOSFET.

For a through hole design, several electrolytic capacitors may be needed. For surface mount designs, solid tantalum capacitors can be used, but caution must be exercised with regard to the capacitor surge current rating.

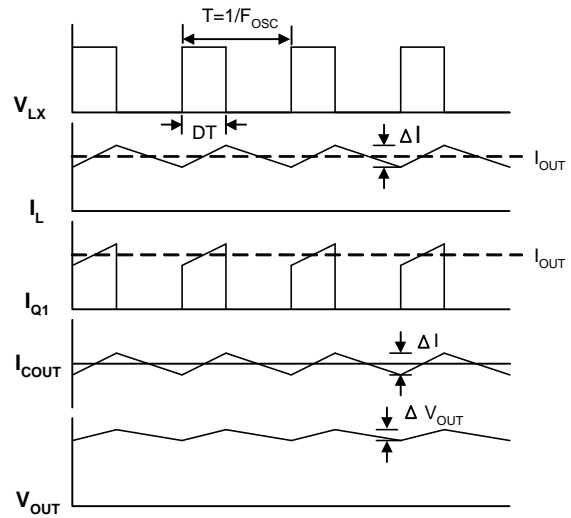
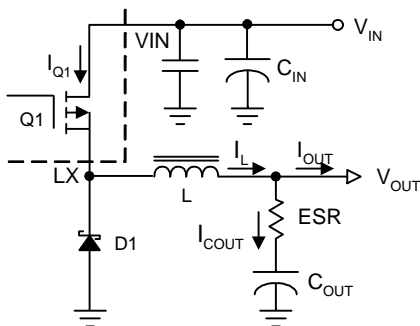

Figure 1 Converter Waveforms

Output Capacitor Selection

An output capacitor is required to filter the output and supply the load transient current. The filtering requirements are the functions of the switching frequency and the ripple current (ΔI). The output ripple is the sum of the voltages, having phase shift, across the ESR and the ideal output capacitor. The peak-to-peak voltage of the ESR is calculated as the following equations:

$$D = \frac{V_{OUT} + V_D}{V_{IN} + V_D} \quad \dots\dots\dots (1)$$

$$\Delta I = \frac{V_{OUT} \cdot (1-D)}{F_{OSC} \cdot L} \quad \dots\dots\dots (2)$$

$$V_{ESR} = \Delta I \cdot ESR \quad (V) \quad \dots\dots\dots (3)$$

where V_D is the forward voltage drop of the diode.

The peak-to-peak voltage of the ideal output capacitor is calculated as the following equation:

$$\Delta V_{COUT} = \frac{\Delta I}{8 \cdot F_{OSC} \cdot C_{OUT}} \quad (V) \quad \dots\dots\dots (4)$$

For the applications, using bulk capacitors, the ΔV_{COUT} is much smaller than the V_{ESR} and can be ignored. Therefore, the AC peak-to-peak output voltage (ΔV_{OUT}) is shown below:

$$\Delta V_{OUT} = \Delta I \cdot ESR \quad (V) \quad \dots\dots\dots (5)$$

Application Information (Cont.)

Output Capacitor Selection (Cont.)

For the applications, using ceramic capacitors, the V_{ESR} is much smaller than the ΔV_{COUT} and can be ignored. Therefore, the AC peak-to-peak output voltage (ΔV_{OUT}) is close to ΔV_{COUT} .

The load transient requirements are the functions of the slew rate (di/dt) and the magnitude of the transient load current. These requirements generally met with a mix of capacitors and careful layout. High frequency capacitors initially supply the transient and slow the current load rate seen by the bulk capacitors. The bulk filter capacitor values are generally determined by the ESR (Effective Series Resistance) and voltage rating requirements rather than actual capacitance requirements.

High frequency decoupling capacitors should be placed physically as close to the power pins of the load as possible. Be careful not to add inductance in the circuit board wiring that could cancel the usefulness of these low inductance components. An aluminum electrolytic capacitor's ESR value is related to the case size with lower ESR available in larger case sizes. However, the Equivalent Series Inductance (ESL) of these capacitors increases with case size and can reduce the usefulness of the capacitor to high slew-rate transient loading.

Inductor Value Calculation

The operating frequency and inductor selection are interrelated in that higher operating frequencies permit the use of a smaller inductor for the same amount of inductor ripple current. However, this is at the expense of efficiency due to an increase in MOSFET gate charge losses. The equation (2) shows that the inductance value has a direct effect on ripple current.

Accepting larger values of ripple current allows the use of low inductances, but results in higher output voltage ripple and greater core losses. A reasonable starting point for setting ripple current is $\Delta I \leq 0.4 \cdot I_{OUT(MAX)}$. Remember, the maximum ripple current occurs at the maximum input voltage. The minimum inductance of the inductor is calculated as the following equation:

$$\frac{V_{OUT} \cdot (V_{IN} - V_{OUT})}{500000 \cdot L \cdot V_{IN}} \leq 1.2$$

$$L \geq \frac{V_{OUT} \cdot (V_{IN} - V_{OUT})}{600000 \cdot V_{IN}} \quad (H) \quad \dots\dots\dots (6)$$

where $V_{IN} = V_{IN(MAX)}$

Output Diode Selection

The Schottky diode carries load current during the off-time. The average diode current is therefore dependent on the P-channel power MOSFET duty cycle. At high input voltages the diode conducts most of the time. As V_{IN} approaches V_{OUT} , the diode conducts only a small fraction of the time. The most stressful condition for the diode is when the output is short-circuited. Therefore, it is important to adequately specify the diode peak current and average power dissipation so as not to exceed the diode ratings.

Under normal load conditions, the average current conducted by the diode is:

$$I_D = \frac{V_{IN} - V_{OUT}}{V_{IN} + V_D} \cdot I_{OUT}$$

The APW7143 is equipped with whole protections to reduce the power dissipation during short-circuit condition. Therefore, the maximum power dissipation of the diode is calculated from the maximum output current as:

$$P_{DIODE(MAX)} = V_D \cdot I_{D(MAX)}$$

where $I_{OUT} = I_{OUT(MAX)}$

Remember to keep leading length short and observing proper grounding to avoid ringing and increasing dissipation.

Layout Consideration

In high power switching regulator, a correct layout is important to ensure proper operation of the regulator. In general, interconnecting impedance should be minimized by using short, wide printed circuit traces. Signal and power grounds are to be kept separate and finally combined using ground plane construction or single point grounding. Figure 2 illustrates the layout, with bold lines indicating high current paths. Components along the bold lines should be placed close together. Below is a checklist for your layout:

1. Begin the layout by placing the power components first. Orient the power circuitry to achieve a clean power flow path. If possible, make all the connections on one side of the PCB with wide, copper filled areas.
2. In Figure 2, the loops with same color bold lines conduct high slew rate current. These interconnecting impedances should be minimized by using wide and short printed circuit traces.
3. Keep the sensitive small signal nodes (FB, COMP) away from switching nodes (LX or others) on the PCB. Therefore, place the feedback divider and the feedback compensation network close to the IC to avoid switching noise. Connect the ground of feedback divider directly to the AGND pin of the IC using a dedicated ground trace.

4. Place the decoupling ceramic capacitor C1 near the VIN as close as possible. The bulk capacitors C5 are also placed near VIN. Use a wide power ground plane to connect the C1, C2, C5, and Schottky diode to provide a low impedance path between the components for large and high slew rate current.

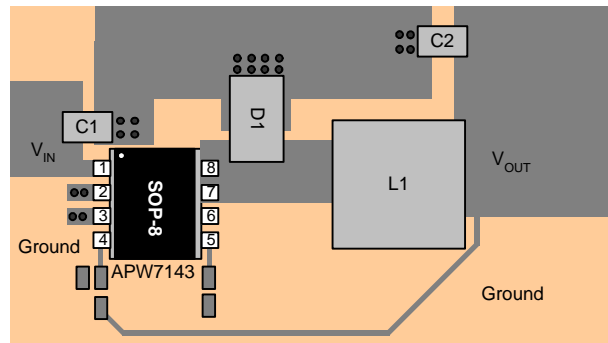

Figure 3 Recommended Layout Diagram

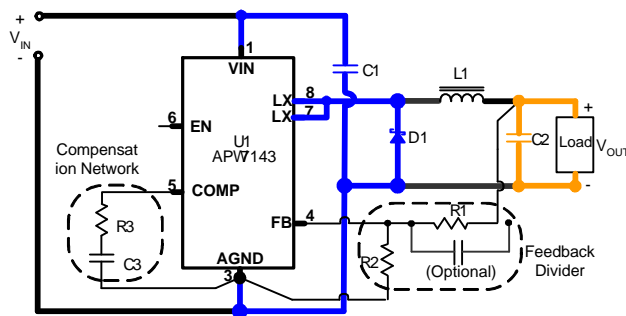
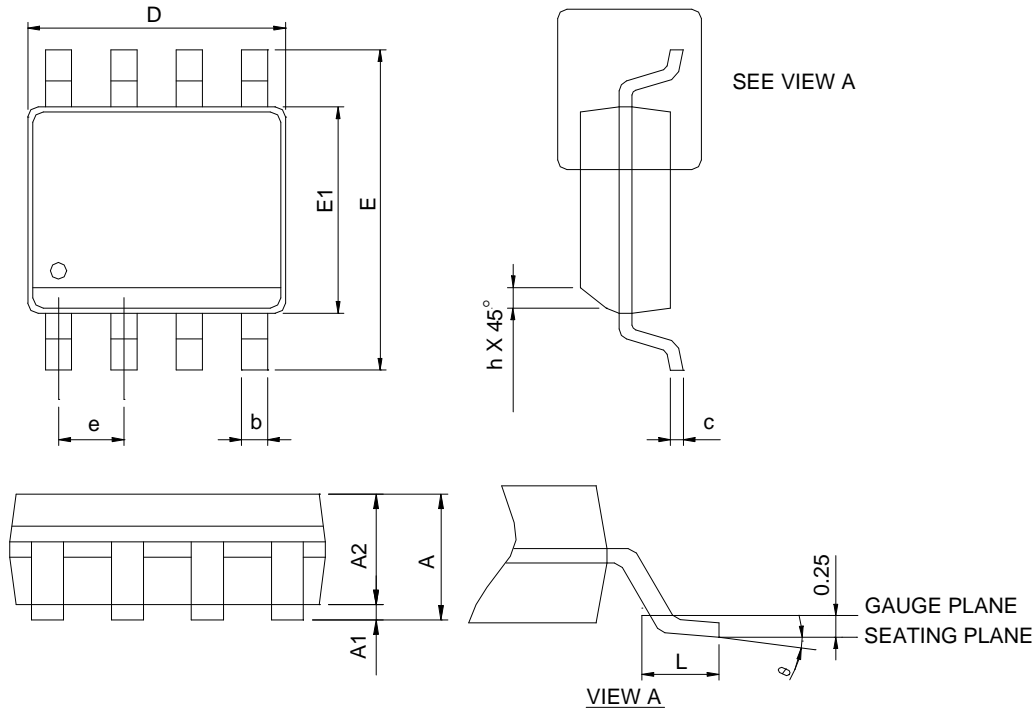

Figure 2 Current Path Diagram

Package Information

SOP-8



SYMBOL	SOP-8			
	MILLIMETERS		INCHES	
	MIN.	MAX.	MIN.	MAX.
A		1.75		0.069
A1	0.10	0.25	0.004	0.010
A2	1.25		0.049	
b	0.31	0.51	0.012	0.020
c	0.17	0.25	0.007	0.010
D	4.80	5.00	0.189	0.197
E	5.80	6.20	0.228	0.244
E1	3.80	4.00	0.150	0.157
e	1.27 BSC		0.050 BSC	
h	0.25	0.50	0.010	0.020
L	0.40	1.27	0.016	0.050
θ	0°	8°	0°	8°

- Note: 1. Follow JEDEC MS-012 AA.
 2. Dimension "D" does not include mold flash, protrusions or gate burrs. Mold flash, protrusion or gate burrs shall not exceed 6 mil per side.
 3. Dimension "E" does not include inter-lead flash or protrusions. Inter-lead flash and protrusions shall not exceed 10 mil per side.

Carrier Tape & Reel Dimensions

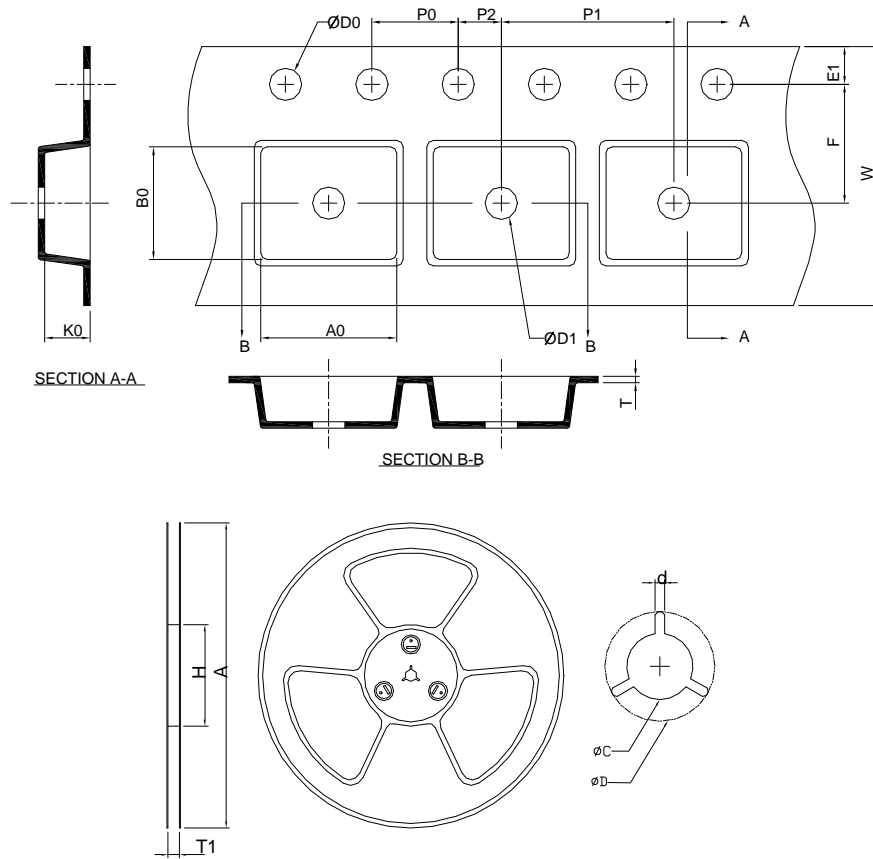

Application	A	H	T1	C	d	D	W	E1	F
SOP-8(P)	330.0 ±0.00	50 MIN.	12.4+2.00 -0.00	13.0+0.50 -0.20	1.5 MIN.	20.2 MIN.	12.0 ±0.30	1.75 ±0.10	5.5 ±0.05
	P0	P1	P2	D0	D1	T	A0	B0	K0
	4.0 ±0.10	8.0 ±0.10	2.0 ±0.05	1.5+0.10 -0.00	1.5 MIN.	0.6+0.00 -0.40	6.40 ±0.20	5.20 ±0.20	2.10 ±0.20

(mm)

Devices Per Unit

Package Type	Unit	Quantity
SOP-8	Tape & Reel	2500

Reflow Condition (IR/Convection or VPR Reflow)

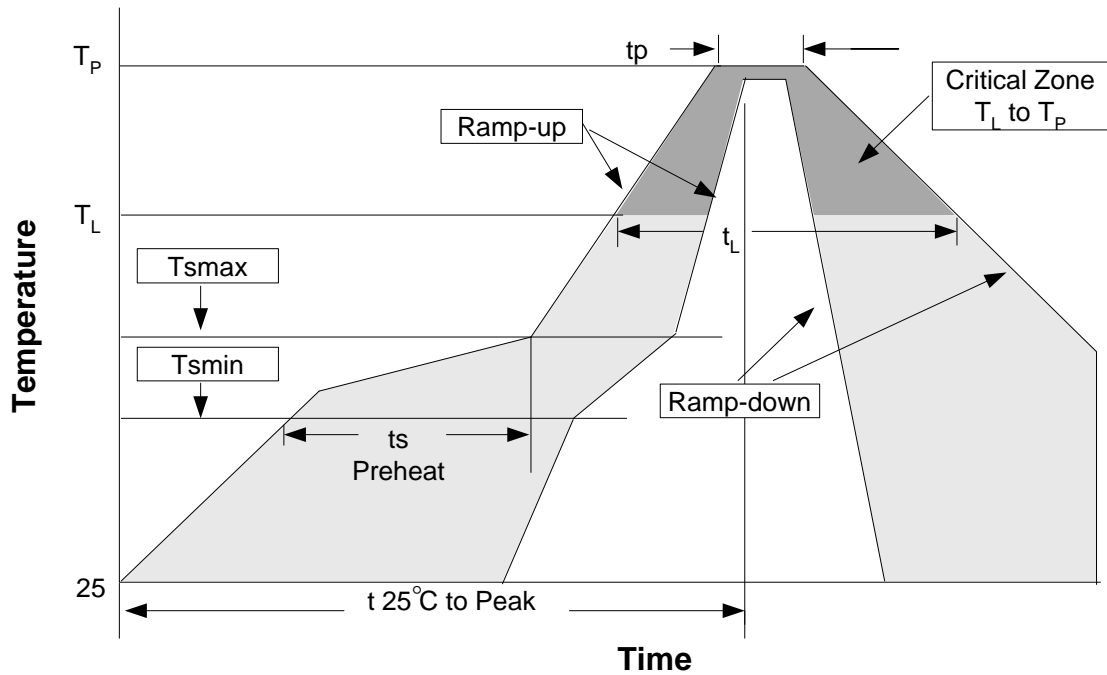

Reliability Test Program

Test item	Method	Description
SOLDERABILITY	MIL-STD-883D-2003	245°C, 5 sec
HOLT	MIL-STD-883D-1005.7	1000 Hrs Bias @ 125°C
PCT	JESD-22-B, A102	168 Hrs, 100%RH, 121°C
TST	MIL-STD-883D-1011.9	-65°C~150°C, 200 Cycles
ESD	MIL-STD-883D-3015.7	VHBM > 2KV, VMM > 200V
Latch-Up	JESD 78	10ms, 1 _{tr} > 100mA

Classification Reflow Profiles

Profile Feature	Sn-Pb Eutectic Assembly	Pb-Free Assembly
Average ramp-up rate (T _L to T _P)	3°C/second max.	3°C/second max.
Preheat		
- Temperature Min (T _{min})	100°C	150°C
- Temperature Max (T _{max})	150°C	200°C
- Time (min to max) (t _s)	60-120 seconds	60-180 seconds
Time maintained above:		
- Temperature (T _L)	183°C	217°C
- Time (t _L)	60-150 seconds	60-150 seconds
Peak/Classification Temperature (T _p)	See table 1	See table 2
Time within 5°C of actual Peak Temperature (t _p)	10-30 seconds	20-40 seconds
Ramp-down Rate	6°C/second max.	6°C/second max.
Time 25°C to Peak Temperature	6 minutes max.	8 minutes max.

Notes: All temperatures refer to topside of the package. Measured on the body surface.

Classification Reflow Profiles (Cont.)

Table 1. SnPb Eutectic Process – Package Peak Reflow Temperatures

Package Thickness	Volume mm ³ <350	Volume mm ³ ≥350
<2.5 mm	240 +0/-5°C	225 +0/-5°C
≥2.5 mm	225 +0/-5°C	225 +0/-5°C

Table 2. Pb-free Process – Package Classification Reflow Temperatures

Package Thickness	Volume mm ³ <350	Volume mm ³ 350-2000	Volume mm ³ >2000
<1.6 mm	260 +0°C*	260 +0°C*	260 +0°C*
1.6 mm – 2.5 mm	260 +0°C*	250 +0°C*	245 +0°C*
≥2.5 mm	250 +0°C*	245 +0°C*	245 +0°C*

*Tolerance: The device manufacturer/supplier **shall** assure process compatibility up to and including the stated classification temperature (this means Peak reflow temperature +0°C. For example 260°C+0°C) at the rated MSL level.

Customer Service

Anpec Electronics Corp.

Head Office :

No.6, Dusing 1st Road, SBIP,
Hsin-Chu, Taiwan
Tel : 886-3-5642000
Fax : 886-3-5642050

Taipei Branch :

2F, No. 11, Lane 218, Sec 2 Jhongsing Rd.,
Sindian City, Taipei County 23146, Taiwan
Tel : 886-2-2910-3838
Fax : 886-2-2917-3838