

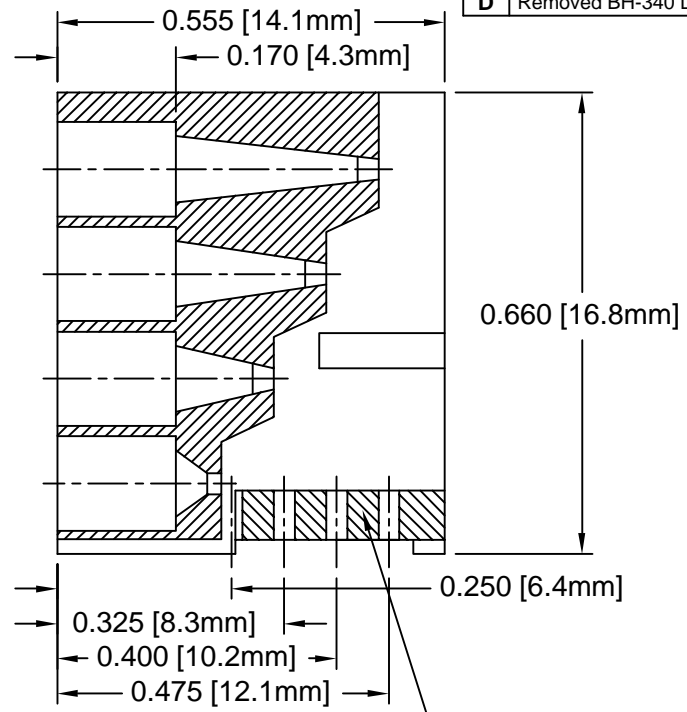

REV.	DESCRIPTION	DATE	APPROVED
B	Engineering Update w/o Changes	02/27/04	M. C.
C	Changed Section View from Left Holes to Right Holes. Changed bottom holes from .030 SQ. to .020X.030.	01/20/05	M. C.
D	Removed BH-340 Dimensions	08/16/07	M. C.

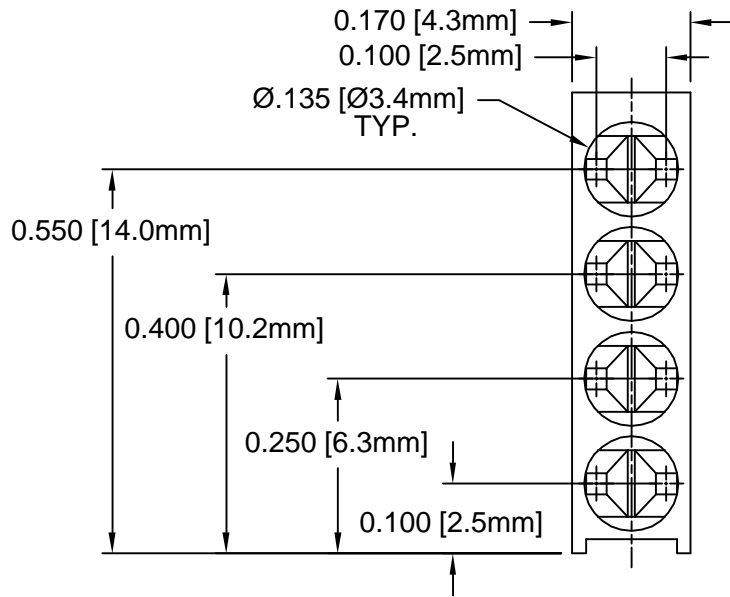

BH-340 SPACER
PACKED SEPARATELY

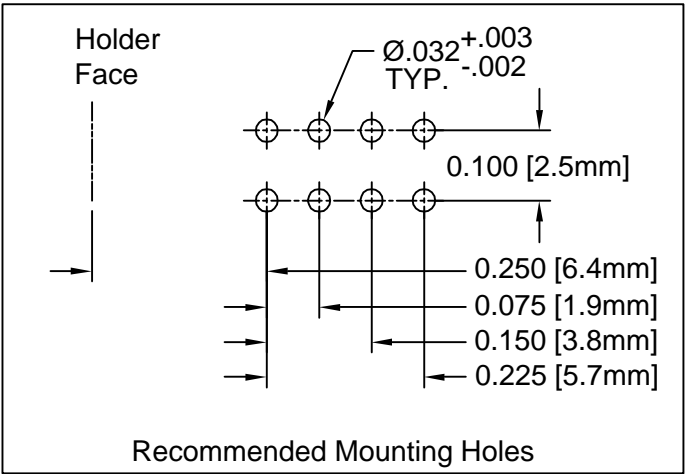

2. MATERIAL: NYLON 6/6, 94V-0, BLACK. BIVAR MATERIAL CODE 22-BK.
RTP POLYAMIDE NYLON 6/6, 0200 FR, BLACK OR MODIFIED PLASTICS MN6/6-SE BK.
1. GENERAL SPECIFICATIONS: BIVAR MOLDED COMPONENT SPECIFICATION BV00-E101.

STANDARD TOLERANCE (UNLESS OTHERWISE SPECIFIED)		 4 THOMAS, IRVINE, CA. 92618 TEL: (949) 951-8808 FAX: (949) 951-3974	
DECIMALS	ANGULAR		
.X ±.1	X° ± 1°	 TITLE: QUAD LEVEL T-1 (3mm) LED HOLDER TWO-PIECE	
.XX ±.01			
.XXX ±.005			
DESIGNED: Shane Irving	DATE: 06/24/02	PART NO: H-455C	REVISION: D
CHECKED: M. Chen	DATE: 06/25/02	CAGE CODE : 32559	SHEET # 1 OF 1
CAD GENERATED DOCUMENT. DO NOT MEASURE DRAWING.			