

## Application Note

# CS4297A/CS4299 EMI REDUCTION TECHNIQUES

### 1. INTRODUCTION

The CS4297A and CS4299 AC '97 audio codecs are based on a new and faster fabrication process, and certain precautions in the analog I/O circuitry may be required to prevent 49.1 MHz common-mode radiation. Note that 49.1 MHz is 2 times the CS4297A internal clock frequency of 24.576 MHz.

### 2. DESCRIPTION

Common-mode radiation is the result of undesired voltage drops due to voltage differentials in the I/O ground system. The CS4297A clock transitions result in a rush of current that may induce the digital ground plane to "bounce". When external speaker or microphone cables are connected to the audio system, any common-mode voltage potential on the analog ground will drive the cables (antennas) and radiate electric fields. The magnitude of the electric fields are the result of the I/O cable length (the antenna) and the magnitude of common-mode current.

### 3. EMI SHUNTING CIRCUIT

The key to reducing common-mode emissions is to add decoupling (called shunting) at the audio I/O connectors. The shunt capacitors must be connected to a "clean" (free of digital noise) I/O ground. The recommended EMI shunting circuit is shown in the following diagram, and includes ferrite beads and 1000 pF NPO capacitors. The ferrite bead values are typically selected for an impedance of 100 ohms at 100 MHz. The ferrite bead and capacitor circuit create a low pass filter to attenuate frequencies above 1.6 MHz.

Additionally, the following PCB layout checklist includes generally accepted practices for reducing both differential-mode and common-mode radiated emissions, while maintaining audio quality.

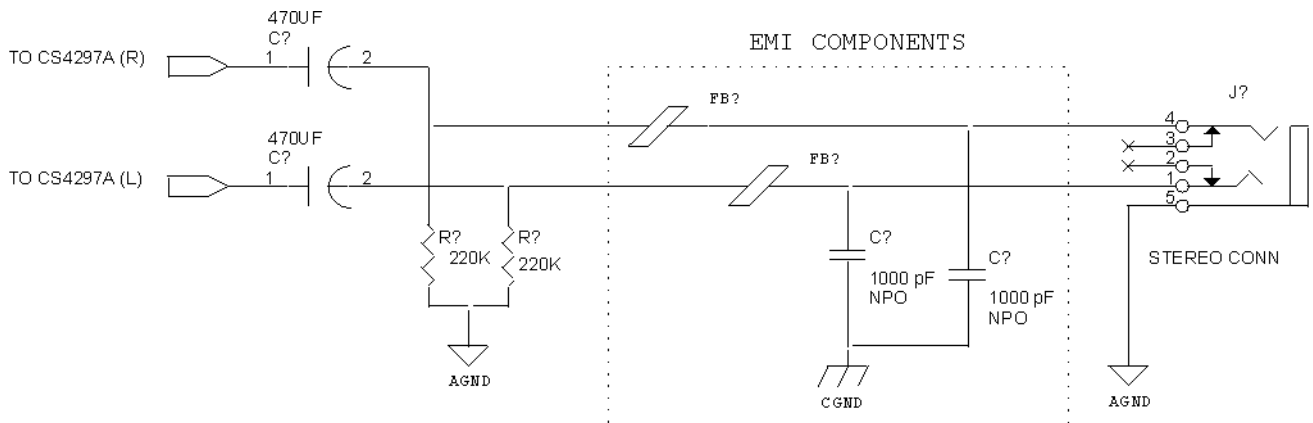

#### 4. PCB LAYOUT CHECKLIST

- Connect analog and digital ground together with a 1/16 inch trace under the CS4297A. A direct connection between analog and digital ground will reduce the differential-mode radiation and improve the EOS (Electrical Overstress) capabilities of the CS4297A.
- Construct a "clean" chassis ground on the PCB around the I/O connectors, and connect the I/O ground to the system frame ground.
- Connect chassis ground to digital ground in a quiet area, away from the CS4297A.
- The ferrite bead and decoupling capacitor combination shown in the block diagram on page one of this document, form a low-pass filter to remove the common-mode voltages. The decoupling capacitor must be terminated to a clean (free of digital noise) I/O chassis ground. A separate analog ground return path between the I/O connectors and analog ground plane must be maintained to reduce loop areas.
- Chassis and analog planes should be identical on all layers, and the gap or "moat" between planes should be 1/8 inch to prevent coupling between planes. The absolute minimum moat spacing is 1/16 inch. Do not overlap digital and analog ground planes.
- Never route digital traces or digital planes under the analog or I/O chassis ground areas. Analog components should be located over analog planes and digital components should be located over digital planes.

---

#### Contacting Cirrus Logic Support

For a complete listing of Direct Sales, Distributor, and Sales Representative contacts, visit the Cirrus Logic web site at: <http://www.cirrus.com/corporate/contacts/>

---

Preliminary product information describes products which are in production, but for which full characterization data is not yet available. Advance product information describes products which are in development and subject to development changes. Cirrus Logic, Inc. has made best efforts to ensure that the information contained in this document is accurate and reliable. However, the information is subject to change without notice and is provided "AS IS" without warranty of any kind (express or implied). No responsibility is assumed by Cirrus Logic, Inc. for the use of this information, nor for infringements of patents or other rights of third parties. This document is the property of Cirrus Logic, Inc. and implies no license under patents, copyrights, trademarks, or trade secrets. No part of this publication may be copied, reproduced, stored in a retrieval system, or transmitted, in any form or by any means (electronic, mechanical, photographic, or otherwise) without the prior written consent of Cirrus Logic, Inc. Items from any Cirrus Logic website or disk may be printed for use by the user. However, no part of the printout or electronic files may be copied, reproduced, stored in a retrieval system, or transmitted, in any form or by any means (electronic, mechanical, photographic, or otherwise) without the prior written consent of Cirrus Logic, Inc. Furthermore, no part of this publication may be used as a basis for manufacture or sale of any items without the prior written consent of Cirrus Logic, Inc. The names of products of Cirrus Logic, Inc. or other vendors and suppliers appearing in this document may be trademarks or service marks of their respective owners which may be registered in some jurisdictions. A list of Cirrus Logic, Inc. trademarks and service marks can be found at <http://www.cirrus.com>.

***CRYSTAL***

---

• Notes •

---