HD74LVC16541

16-bit Buffers / Line Drivers with 3-state Outputs

HITACHI

ADE-205-058B(Z)

Rev.2

September 1995

Description

The HD74LVC16541 has sixteen buffers with three state outputs in a 48 pin package. When G1 and G2 is low level, this drivers set up output is enable. Low voltage and high speed operation is suitable at the battery drive product (note type personal computer) and low power consumption extends the life of a battery for long time operation.

Features

- $V_{CC} = 2.0\text{ V to }5.5\text{ V}$
- All inputs $V_{IH}(\text{Max.}) = 5.5\text{ V} (@V_{CC} = 0\text{ V to }5.5\text{ V})$
- Typical V_{OL} ground bounce $< 0.8\text{ V} (@V_{CC} = 3.3\text{ V}, T_a = 25^\circ\text{C})$
- Typical V_{OH} undershoot $> 2.0\text{ V} (@V_{CC} = 3.3\text{ V}, T_a = 25^\circ\text{C})$
- High output current $\pm 24\text{ mA} (@V_{CC} = 3.0\text{ V to }5.5\text{ V})$

Function Table

Inputs			Output Y
G1	G2	A	
L	L	L	L
L	L	H	H
H	X	X	Z
X	H	X	Z

H : High level

L : Low level

X : Immaterial

Z : High impedance

HD74LVC16541

Pin Arrangement

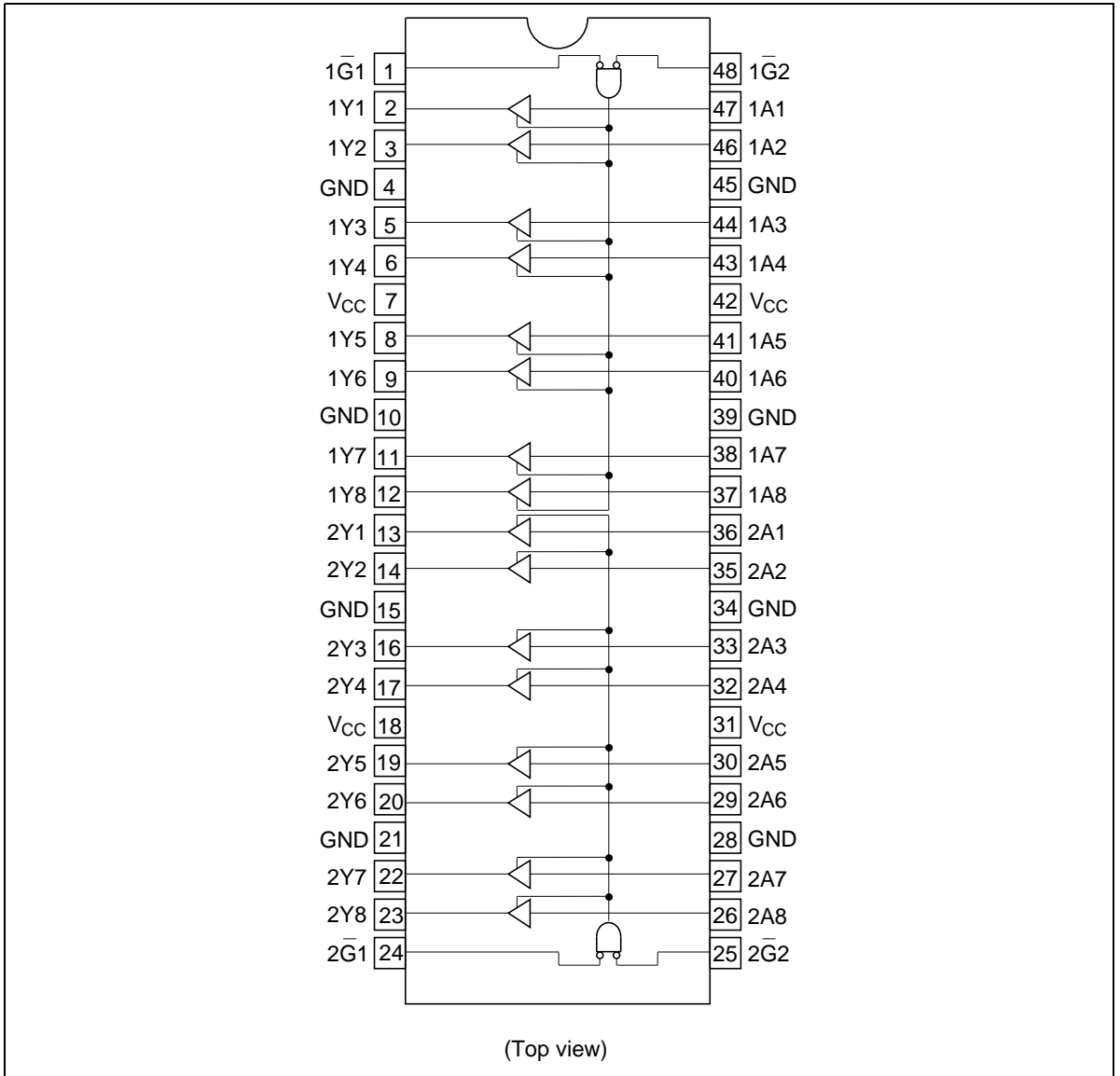

Absolute Maximum Ratings

Item	Symbol	Ratings	Unit	Conditions
Supply voltage	V_{CC}	-0.5 to 6.0	V	
Input diode current	I_{IK}	-50	mA	$V_I = -0.5\text{ V}$
Input voltage	V_I	-0.5 to 6.0	V	
Output diode current	I_{OK}	-50	mA	$V_O = -0.5\text{ V}$
		50	mA	$V_O = V_{CC} + 0.5\text{ V}$
Output voltage	V_O	-0.5 to $V_{CC} + 0.5$	V	
Output current	I_O	± 50	mA	
V_{CC} , GND current / pin	I_{CC} or I_{GND}	100	mA	
Storage temperature	T_{stg}	-65 to +150	$^{\circ}\text{C}$	

Note: The absolute maximum ratings are values which must not individually be exceeded, and furthermore, no two of which may be realized at the same time.

Recommended Operating Conditions

Item	Symbol	Ratings	Unit	Conditions
Supply voltage	V_{CC}	1.5 to 5.5	V	Data retention
		2.0 to 5.5	V	At operation
Input / output voltage	V_I	0 to 5.5	V	G, A
	V_O	0 to V_{CC}	V	Y
Operating temperature	T_a	-40 to 85	$^{\circ}\text{C}$	
Output current	I_{OH}	-12	mA	$V_{CC} = 2.7\text{ V}$
		-24^{*2}	mA	$V_{CC} = 3.0\text{ V to } 5.5\text{ V}$
	I_{OL}	12	mA	$V_{CC} = 2.7\text{ V}$
		24^{*2}	mA	$V_{CC} = 3.0\text{ V to } 5.5\text{ V}$
Input rise / fall time ^{*1}	t_r, t_f	10	ns/V	

Notes: 1. This item guarantees maximum limit when one input switches.

Waveform : Refer to test circuit of switching characteristics.

2. duty cycle $\leq 50\%$

HD74LVC16541

Electrical Characteristics

Item	Symbol	V_{CC} (V)	Ta = -40 to 85°C		Unit	Test Conditions
			Min	Max		
Input voltage	V_{IH}	2.7 to 3.6	2.0	—	V	
		4.5 to 5.5	$V_{CC} \times 0.7$	—	V	
	V_{IL}	2.7 to 3.6	—	0.8	V	
		4.5 to 5.5	—	$V_{CC} \times 0.3$	V	
Output voltage	V_{OH}	2.7 to 5.5	$V_{CC} - 0.2$	—	V	$I_{OH} = -100 \mu A$
		2.7	2.2	—	V	$I_{OH} = -12 \text{ mA}$
		3.0	2.4	—	V	
		3.0	2.0	—	V	$I_{OH} = -24 \text{ mA}$
		4.5	3.8	—	V	
	V_{OL}	2.7 to 5.5	—	0.2	V	$I_{OL} = 100 \mu A$
		2.7	—	0.4	V	$I_{OL} = 12 \text{ mA}$
		3.0	—	0.55	V	$I_{OL} = 24 \text{ mA}$
		4.5	—	0.55	V	
Input current	I_{IN}	0 to 5.5	—	± 5.0	μA	$V_{IN} = 5.5 \text{ V or GND}$
Off state output current	I_{OZ}	5.5	—	± 10	μA	$V_{IN} = V_{CC}, \text{ GND}$ $V_{OUT} = V_{CC} \text{ or GND}$
Quiescent supply current	I_{CC}	5.5	—	40	μA	$V_{IN} = V_{CC} \text{ or GND}$
	ΔI_{CC}	3.0 to 3.6	—	500	μA	$V_{IN} = \text{one input at } (V_{CC} - 0.6) \text{ V,}$ other inputs at $V_{CC} \text{ or GND}$

Switching Characteristics

Item	Symbol	V _{CC} (V)	Ta = -40 to 85°C			Unit	From (Input)	To (Output)
			Min	Typ	Max			
Propagation delay time	t _{PLH}	2.7	—	4.5	7.5	ns	A	Y
	t _{PHL}	3.3±0.3	1.5	3.5	6.5	ns		
		5.0±0.5	—	2.5	5.0	ns		
Output enable time	t _{ZH}	2.7	—	5.5	9.0	ns	G	Y
	t _{ZL}	3.3±0.3	1.5	4.0	8.0	ns		
		5.0±0.5	—	3.0	6.5	ns		
Output disable time	t _{HZ}	2.7	—	4.0	8.5	ns	G	Y
	t _{LZ}	3.3±0.3	1.5	3.5	7.5	ns		
		5.0±0.5	—	2.5	6.0	ns		
Input capacitance	C _{IN}	2.7	—	3.0	—	pF		
Output capacitance	C _O	2.7	—	15.0	—	pF		

Test Circuit

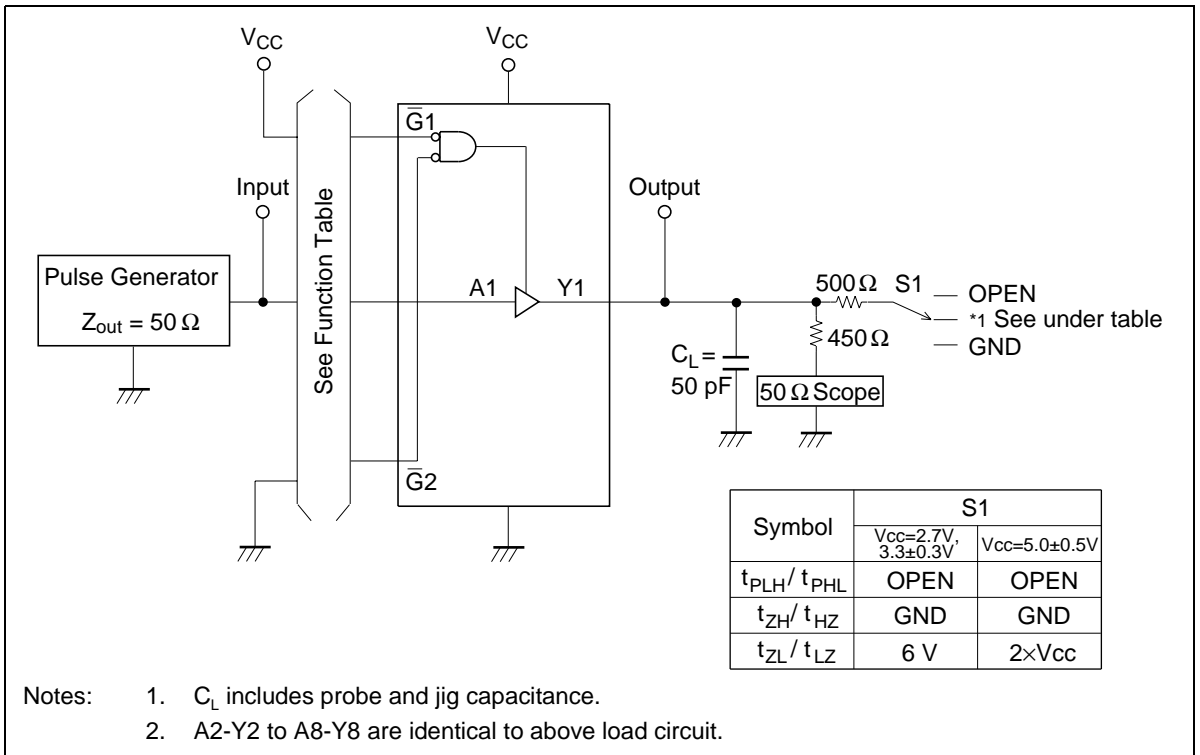

HD74LVC16541

Waveforms – 1

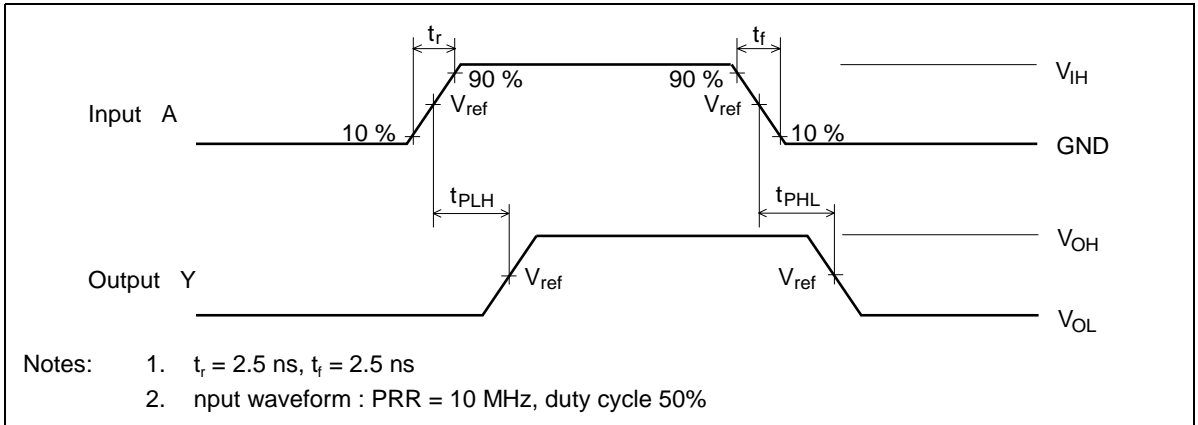

Waveforms – 2

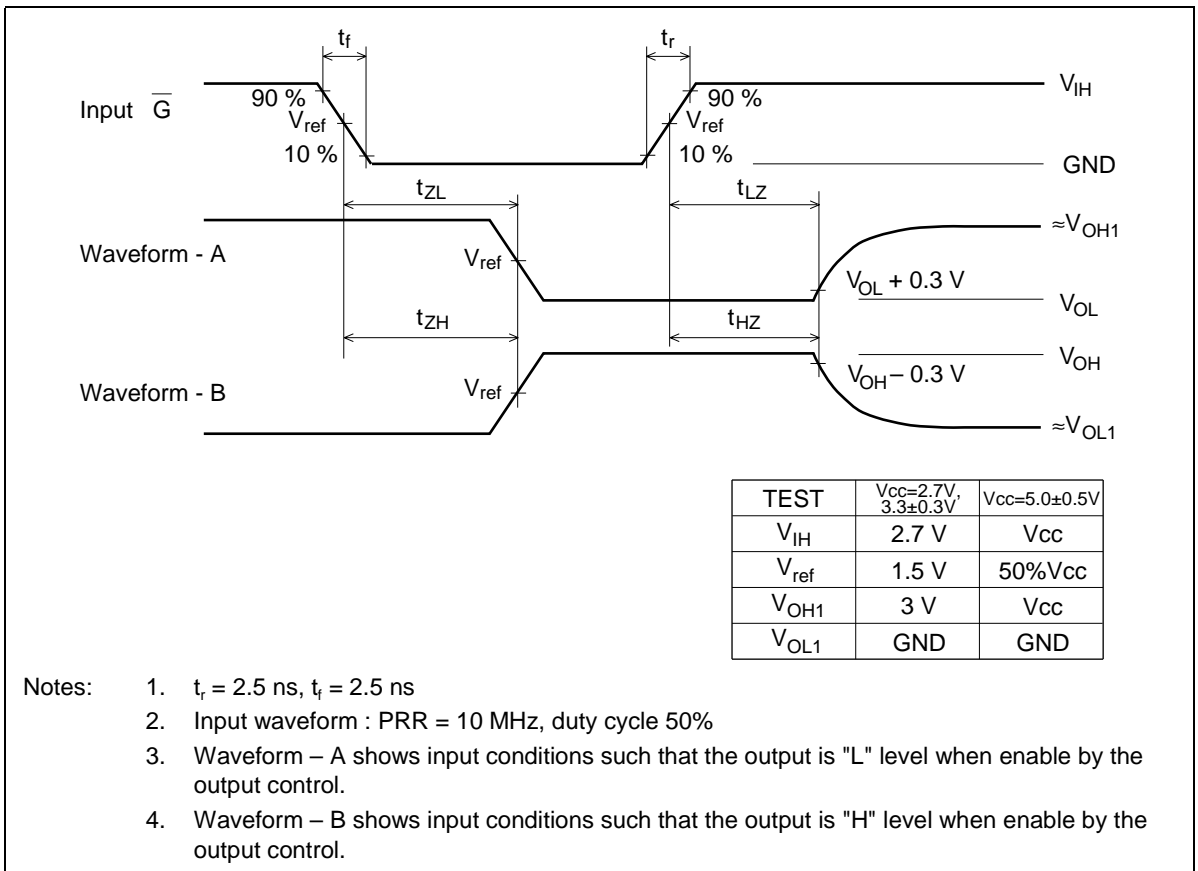

Package Dimensions

Unit: mm

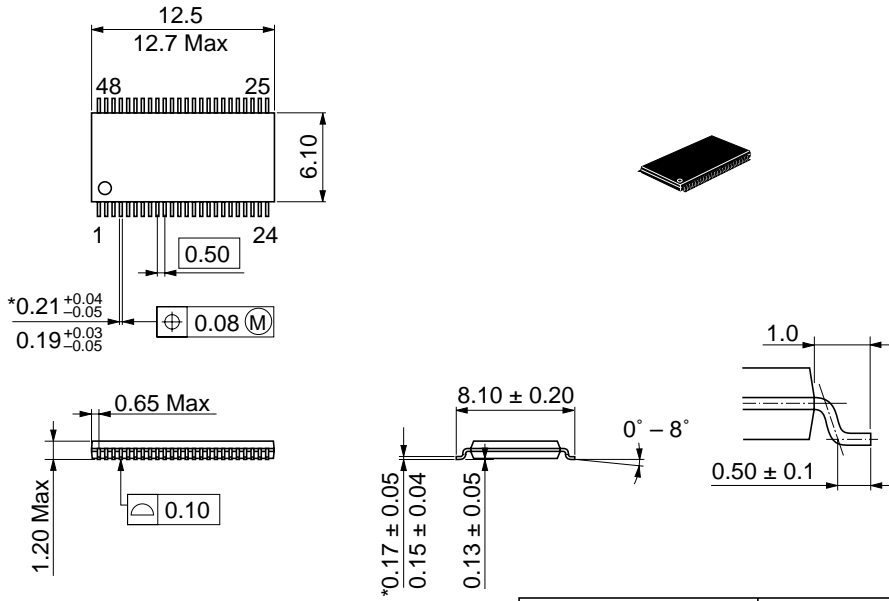

*Dimension including the plating thickness

 Base material dimension

Hitachi Code	TTP-48DB
JEDEC	—
EIAJ	—
Mass (reference value)	0.20 g

Disclaimer

1. Hitachi neither warrants nor grants licenses of any rights of Hitachi's or any third party's patent, copyright, trademark, or other intellectual property rights for information contained in this document. Hitachi bears no responsibility for problems that may arise with third party's rights, including intellectual property rights, in connection with use of the information contained in this document.
2. Products and product specifications may be subject to change without notice. Confirm that you have received the latest product standards or specifications before final design, purchase or use.
3. Hitachi makes every attempt to ensure that its products are of high quality and reliability. However, contact Hitachi's sales office before using the product in an application that demands especially high quality and reliability or where its failure or malfunction may directly threaten human life or cause risk of bodily injury, such as aerospace, aeronautics, nuclear power, combustion control, transportation, traffic, safety equipment or medical equipment for life support.
4. Design your application so that the product is used within the ranges guaranteed by Hitachi particularly for maximum rating, operating supply voltage range, heat radiation characteristics, installation conditions and other characteristics. Hitachi bears no responsibility for failure or damage when used beyond the guaranteed ranges. Even within the guaranteed ranges, consider normally foreseeable failure rates or failure modes in semiconductor devices and employ systemic measures such as fail-safes, so that the equipment incorporating Hitachi product does not cause bodily injury, fire or other consequential damage due to operation of the Hitachi product.
5. This product is not designed to be radiation resistant.
6. No one is permitted to reproduce or duplicate, in any form, the whole or part of this document without written approval from Hitachi.
7. Contact Hitachi's sales office for any questions regarding this document or Hitachi semiconductor products.

Sales Offices

HITACHI

Hitachi, Ltd.

Semiconductor & Integrated Circuits.
Nippon Bldg., 2-6-2, Ohte-machi, Chiyoda-ku, Tokyo 100-0004, Japan
Tel: Tokyo (03) 3270-2111 Fax: (03) 3270-5109

URL NorthAmerica : <http://semiconductor.hitachi.com/>
Europe : <http://www.hitachi-eu.com/hel/ecg>
Asia : <http://sicapac.hitachi-asia.com>
Japan : <http://www.hitachi.co.jp/Sicd/indx.htm>

For further information write to:

Hitachi Semiconductor
(America) Inc.
179 East Tasman Drive,
San Jose, CA 95134
Tel: <1>(408) 433-1990
Fax: <1>(408) 433-0223

Hitachi Europe GmbH
Electronic Components Group
Dornacher Straße 3
D-85622 Feldkirchen, Munich
Germany
Tel: <49> (89) 9 9180-0
Fax: <49> (89) 9 29 30 00

Hitachi Europe Ltd.
Electronic Components Group.
Whitebrook Park
Lower Cookham Road
Maidenhead
Berkshire SL6 8YA, United Kingdom
Tel: <44> (1628) 585000
Fax: <44> (1628) 585160

Hitachi Asia Ltd.
Hitachi Tower
16 Collyer Quay #20-00,
Singapore 049318
Tel : <65>-538-6533/538-8577
Fax : <65>-538-6933/538-3877
URL : <http://www.hitachi.com.sg>

Hitachi Asia Ltd.
(Taipei Branch Office)
4/F, No. 167, Tun Hwa North Road,
Hung-Kuo Building,
Taipei (105), Taiwan
Tel : <886>-(2)-2718-3666
Fax : <886>-(2)-2718-8180
Telex : 23222 HAS-TP
URL : <http://www.hitachi.com.tw>

Hitachi Asia (Hong Kong) Ltd.
Group III (Electronic Components)
7/F., North Tower,
World Finance Centre,
Harbour City, Canton Road
Tsim Sha Tsui, Kowloon,
Hong Kong
Tel : <852>-(2)-735-9218
Fax : <852>-(2)-730-0281
URL : <http://www.hitachi.com.hk>

Copyright © Hitachi, Ltd., 2000. All rights reserved. Printed in Japan.
Colophon 2.0