

SWITCHING IC

PEF 20450 MTSI
PEF 20470 MTSI-L
PEF 24470 MTSI-XL
Version 1.3

Wired
Communications



Never stop thinking.

Edition 2001-11-20

**Published by Infineon Technologies AG,
St.-Martin-Strasse 53,
D-81541 München, Germany**

**© Infineon Technologies AG 2001.
All Rights Reserved.**

Attention please!

The information herein is given to describe certain components and shall not be considered as warranted characteristics.

Terms of delivery and rights to technical change reserved.

We hereby disclaim any and all warranties, including but not limited to warranties of non-infringement, regarding circuits, descriptions and charts stated herein.

Infineon Technologies is an approved CECC manufacturer.

Information

For further information on technology, delivery terms and conditions and prices please contact your nearest Infineon Technologies Office in Germany or our Infineon Technologies Representatives worldwide (see address list).

Warnings

Due to technical requirements components may contain dangerous substances. For information on the types in question please contact your nearest Infineon Technologies Office.

Infineon Technologies Components may only be used in life-support devices or systems with the express written approval of Infineon Technologies, if a failure of such components can reasonably be expected to cause the failure of that life-support device or system, or to affect the safety or effectiveness of that device or system. Life support devices or systems are intended to be implanted in the human body, or to support and/or maintain and sustain and/or protect human life. If they fail, it is reasonable to assume that the health of the user or other persons may be endangered.

SWITI

Switching IC

PEF 20450 MTSI

PEF 20470 MTSI-L

PEF 24470 MTSI-XL

Version 1.3

Wired
Communications



Previous Version:

PEF 20450 / 20470 / 24470 V1.2, Preliminary Data Sheet DS1, 2001-04-04

Page	Content
12	Table 5 updated
26	Chapter 3.4.3 updated, added Figure 9
28	Chapter 3.7.1 and Chapter 3.7.2 updated
30	Chapter 4.2 reworked
49	Description of Configuration Command Register 1 and 2 (CMD1 and CMD2) updated
57	Description of Interrupt Status Register 1 (ISTA1) reworked
58	Description of Interrupt Error Status Register 1 and 2 (IESTA1 and IESTA2) reworked
60	Description of Interrupt Error Mask Register 1 and 2 (INTEM1 and INTEM2) reworked
74	Chapter 6.2 reworked
82	Figure 18 updated
85	Chapter 6.7.3 reworked
101	Chapter 7.1 and Table 22 updated
104	Table 23 updated
110	Table 27 and Figure 39 updated
112	Added Chapter, 7.5“Hardware Reset Timing”
115	Table 32 updated.

For questions on technology, delivery and prices please contact the Infineon Technologies Offices in Germany or the Infineon Technologies Companies and Representatives worldwide: see our webpage at <http://www.infineon.com>

Table of Contents		Page
1	Overview	3
1.1	Overview of Features	5
1.2	Features in Detail	6
1.3	Logic Symbol	8
1.4	Standard PBX or CO Application	10
2	Pin Description	11
2.1	Pin Diagrams	11
2.2	Pin Definitions and Functions	12
2.2.1	Local Bus Interface (PCM)	12
2.2.2	General Purpose Port	12
2.2.3	Clock Signals	12
2.2.4	JTAG Interface	13
2.2.5	Microprocessor Interface	13
2.2.6	Power Supply	14
3	Architectural Description	15
3.1	Functional Block Diagram	15
3.2	Overview of Functional Blocks	16
3.3	Switching Factory	17
3.3.1	Switching Modes	17
3.3.1.1	Minimum and Constant Delay	17
3.3.1.2	Subchannel Switching	17
3.3.1.3	Multipoint Switching	17
3.3.1.4	Broadcast Switching	18
3.3.1.5	Bidirectional Switching	18
3.3.1.6	Message Mode	19
3.3.2	Parallel Mode for Local Bus	19
3.3.3	Switching Block Error Handling	20
3.3.4	Analyze Connection and Data Memory	20
3.4	Clock Generator and PLL	21
3.4.1	General Overview	21
3.4.2	Analog PLL (APLL)	22
3.4.2.1	Functional Description	23
3.4.2.2	Jitter Transfer Function	25
3.4.3	Phase Alignment	26
3.4.4	PLL Synchronization	27
3.5	Loops	27
3.6	Read SWITL Configuration with Indirect Register Addressing	27
3.7	Power-On and Reset Behavior	28
3.7.1	Hardware Reset	28
3.7.2	Software Reset	28
4	Description of Interfaces	29

Table of Contents		Page
4.1	Local Bus Interface (PCM)	29
4.2	Data Rate	30
4.3	Microprocessor Interface	31
4.3.1	Intel/Siemens or Motorola Mode	31
4.3.2	De-multiplexed or Multiplexed Mode	31
4.4	General Purpose Port (GPIO)	33
4.5	General Purpose Clocks	33
4.5.1	Frame Group Outputs	34
4.5.2	GPCLK as Clock Outputs	34
4.6	JTAG (Boundary Scan)	35
4.6.1	Boundary Scan	35
4.6.2	Test-Access-Port (TAP)	35
4.6.3	TAP Controller	36
4.7	Identification Code via μ P Read Access	38
5	Register Description	39
5.1	Register Overview For 8-Bit Interface	40
5.2	Detailed Register Description For 8-bit Interface	42
5.3	Register Overview For 16-Bit Interface	67
5.4	Detailed Register Description For 16-Bit Interface	68
6	Programming the Device	72
6.1	Read and Write Access	73
6.2	Interrupt Handling	74
6.3	Command and Register Overview	76
6.4	Indirect Configuration Register Access	81
6.5	Initialization Procedure	82
6.6	Clocking Unit	83
6.7	Local Bus (PCM) Line Interface	84
6.7.1	Standby Command	84
6.7.2	Determining Clock Rates	84
6.7.3	Performing Bit Shifting	85
6.7.3.1	Input Bit Shifting	85
6.7.3.2	Output Bit Shifting	86
6.8	Global Clock Signals	87
6.8.1	Framing Groups	87
6.9	Read Time-Slot Value	88
6.10	Establish Connections	89
6.10.1	Establish 8-bit Connections	89
6.10.2	Subchannel Switching	90
6.10.2.1	Establish 4-bit Connections	90
6.10.2.2	Establish 2-bit Connections	91
6.10.2.3	Establish 1-bit Connections	92
6.10.3	Establish Broadcast Connections	93

Table of Contents		Page
6.10.4	Establish Subchannel Broadcast Connection	94
6.10.5	Establish Multipoint Connection	95
6.11	Send Messages	96
6.12	Release Connections	97
6.12.1	Release 8-bit Connections	97
6.12.2	Release 4-bit Connections	97
6.12.3	Release 2-bit Connections	97
6.12.4	Release 1-bit Connections	98
6.12.5	Release Broadcast Connection	99
6.12.6	Release Subchannel Broadcast Connection	99
6.12.7	Release Multipoint Connection	100
6.13	Stop Sending Messages	100
7	Timing Diagrams	101
7.1	PCM Interface Timing	101
7.2	PCM Parallel Mode Timing	104
7.3	Microprocessor Interface Timing	105
7.3.1	Infineon/Intel Timing in De-Multiplexed Mode	105
7.3.2	Infineon/Intel Timing in Multiplexed Mode	106
7.3.3	Motorola Microprocessor Timing	108
7.4	JTAG Interface Timing	110
7.5	Hardware Reset Timing	112
8	Electrical Characteristics	113
8.1	Absolute Maximum Ratings	113
8.2	Operating Range	113
8.3	Crystal Oscillator	114
8.4	DC Characteristics	115
8.5	Capacitances	115
8.6	AC Characteristics	116
9	Package Outlines	117

List of Figures		Page
Figure 1	Logic Symbol	9
Figure 2	Standard PBX or CO Application	10
Figure 3	Pin Configuration	11
Figure 4	Block Diagram	15
Figure 5	Bidirectional Mode	19
Figure 6	SWITI Clock Generator	21
Figure 7	Block Diagram of APLL	23
Figure 8	APLL - Jitter Transfer Function	25
Figure 9	Example of Phase Alignment.	26
Figure 10	PCM Interface Configurations	29
Figure 11	PCM Bit Shifting.	30
Figure 12	Multiplexed and in De-multiplexed Bus Mode	32
Figure 13	GPIO Port Configuration Example	33
Figure 14	Frame Signal Example.	34
Figure 15	Order of Register Access.	72
Figure 16	8-bit μ P Access Interrupt Structure	74
Figure 17	16-bit μ P Access Interrupt Structure	75
Figure 18	Initialization Procedure after Reset	82
Figure 19	Example: Input Bit Shifting.	85
Figure 20	Example: Output Bit Shifting	86
Figure 21	Example Framing Groups	87
Figure 22	Example: 8-bit Connection.	89
Figure 23	Subchannel Address in Time-Slot	90
Figure 24	Example: 4-bit Connection.	90
Figure 25	Example: 2-bit Connection.	91
Figure 26	Example: 1-bit Connection.	92
Figure 27	Example: Broadcast Connection	93
Figure 28	Example: Subchannel Broadcast Connection	94
Figure 29	Example: Multipoint Connection	95
Figure 30	Example: Send Message	96
Figure 31	PCM Timing	101
Figure 32	Parallel Mode Timing	104
Figure 33	Infineon/Intel Read Cycle in De-Multiplexed Mode	106
Figure 34	Infineon/Intel Write Cycle in De-Multiplexed Mode	106
Figure 35	Infineon/Intel Read Cycle in Multiplexed Mode	107
Figure 36	Infineon/Intel Write Cycle in Multiplexed Mode	108
Figure 37	Motorola Read Cycle	109
Figure 38	Motorola Write Cycle	109
Figure 39	Boundary Scan Timing.	111
Figure 40	Hardware Reset Timing	112
Figure 41	External Crystal	114
Figure 42	I/O Wave Form for AC-Test	116
Figure 43	Outlines of P-MQFP-100-2	117

List of Table	Page
Table 1	Who should read what? 2
Table 2	SWITI Family Tree 3
Table 3	Local Bus Interface 12
Table 4	GPIO 12
Table 5	Clock Pins 12
Table 6	JTAG Interface 13
Table 7	Microprocessor Interface 13
Table 8	Power Supply Pins 14
Table 9	TAP Controller Instructions 36
Table 10	Boundary Scan IDCODE 37
Table 11	IDCODE via μ P Read Access 38
Table 12	Register Overview For 8-Bit Interface 40
Table 13	Value Range for SPA/DPA 41
Table 14	Value Range for ITSA/OTSA 41
Table 15	Value Range for SCA 41
Table 16	Register Overview For 16-Bit Interface 67
Table 17	Affected Registers for Connection Commands 76
Table 18	Affected Registers for Configuration Commands 77
Table 19	Connection Command and Parameter Codes 78
Table 20	Configuration Command 1 and Parameter Codes 79
Table 21	Configuration Command 2 and Parameter Code 79
Table 22	PCM Timing 102
Table 23	PCM Parallel Mode Timing 104
Table 24	Infineon/Intel Timing in De-Multiplexed Mode 105
Table 25	Infineon/Intel Timing in Multiplexed Mode 107
Table 26	Motorola Timing 108
Table 27	JTAG Interface Timing 110
Table 28	Hardware Reset Timing 112
Table 29	Absolute Maximum Ratings 113
Table 30	Operating Range 113
Table 31	External Capacitances for Crystal (Recommendation) 114
Table 32	DC Characteristics 115
Table 33	Input/Output Capacitances 115

PRELIMINARY

Preface

The Switching IC (SWITI) is a family of switching devices for a wide area of telecommunication and data communication applications. This document provides complete reference information according to chip interfaces, programming, internal architecture and applications.

Organization of this Document

This Preliminary Data Sheet is divided into 9 chapters. It is organized as follows:

- **Chapter 1, Overview**
Gives a general description of the product and its family, lists the key features, and presents some typical applications.
- **Chapter 2, Pin Description**
Lists pin locations with associated signals, categorizes signals according to function, and describes signals.
- **Chapter 3, Description of Interfaces**
Rough overview of the internal architecture.
- **Chapter 4, Description of Interfaces**
Short introduction of used interfaces.
- **Chapter 5, Register Description**
Gives information about all registers accessible via the microprocessor interface according to address, short name, access, reset value and value range.
- **Chapter 6, Programming the Device**
Gives a variety of examples how to program the device, lists all available command and parameter values.
- **Chapter 7, Timing Diagrams**
Contains timing diagrams.
- **Chapter 8, Electrical Characteristics**
Specification of the electrical parameters.
- **Chapter 9, Package Outlines**
Outlines of the available packages (P-MQFP-100-2).

PRELIMINARY**Table 1 Who should read what?**

Addressed Person	Relevant Chapters
Programmer	3, 5, 6
Board Designer	2, 3, 4, 7, 8, 9

1 Overview

The new switching family, called SWITI, provides a complete and cost-effective solution for all switching systems. The family is divided in two sub-families, the MTSI family and the HTSI family. The Preliminary Data Sheet describes the functionality and characteristic of the MTSI devices.

The devices can be used in today’s switching applications, e.g. conventional PBXs and central offices, as well as in H.100/H.110 applications (only the HTSI family), which are the key to high performing CTI- and Voice-over-IP-applications, one of the most important future technologies in telecommunications.

The main requirements of today’s switching applications are met by the following features:

- Constant delay e.g. to support wide band data switching, or channel bundling
- Bit switching/subchannel switching to support applications such as mobile base stations, DECT, computer telephony

In addition, the SWITI family provides new features to ensure a broad range of configurations to make it possible to adapt the device to all switching applications:

- A compliant H.100/H.110 interface (HTSI)
- 8-channel stream-to-stream switching capability (HTSI)
- Message mode, which allows to assign a preset value to any output time-slot
- GPIO (General Purpose I/O) port, which is controlled from the external μ P

SWITI family. The SWITI family consists of 6 ICs with different switching capacities. The possible configurations are shown in [Table 2](#). The HTSI versions provide an additional H.100 / H.110 interface, while the MTSIs are standard switching devices. All devices can be programmed easily, thus helping the designer/programmer to integrate the device into his application comfortably.

Table 2 SWITI Family Tree

Name	Package	Sales code	Connections	Local bus IN/OUT	H-Bus IO
HTSI-XL (H-Mode)	P-BGA-217-1	PEF24471 HTSI-XL	2048	16/16	32
HTSI-XL (M-Mode)		PEF24471 HTSI-XL		32/32	-
HTSI-L (H-Mode)	P-BGA-217-1	PEF20471 HTSI-L	1024	16/16	32
HTSI-L (M-Mode)		PEF20471 HTSI-L		32/32	-

PRELIMINARY

Overview

Table 2 SWITI Family Tree (cont'd)

Name	Package	Sales code	Connections	Local bus IN/OUT	H-Bus IO
HTSI (H-Mode)	P-BGA-217-1	PEF20451 HTSI	512	16/16	32
HTSI (M-Mode)		PEF20451 HTSI		32/32	-
MTSI-XL	P-MQFP-100-2	PEF24470 MTSI-XL	2048	16/16	-
MTSI-L	P-MQFP-100-2	PEF20470 MTSI-L	1024	16/16	-
MTSI	P-MQFP-100-2	PEF20450 MTSI	512	16/16	-

PRELIMINARY

**Switching IC
SWITI**

PEF 20450 / 20470 / 24470

Version 1.3

CMOS

1.1 Overview of Features

General

- Switching capacity of 512, 1024, or up to 2048 connections of different types between different buses
- Programmable data rates of 2.048 Mbit/s, 4.096 Mbit/s, 8.192 Mbit/s, and 16.384 Mbit/s on per stream basis
- 16 PCM Highways (IN/OUT)
- Constant delay or minimum delay programmable on per connection basis
- Subchannel switching ability of 1-bit, 2-bit, 4-bit wide time-slots
- Programmable clock shift for local bus
- Automatic data rate adaption
- Optional 8-bit parallel input and/or 8-bit parallel output for first 8 lines of local bus
- Broadcast capabilities
- Multipoint switching ability
- Read and write access to all time-slots
- Message mode (time-slot write access)
- Programmable framing group
- GPIO port
- 8-bit μ P-interface supports both Intel and Motorola mode
- Optional 16-bit μ P interface mode (instead of GPIO port)
- On chip PLL for PCM bus clock operation (master/slave)
- JTAG interface
 - Boundary scan according to IEEE 1149.1
- 3.3 V power supply
- 5 V tolerant inputs/outputs

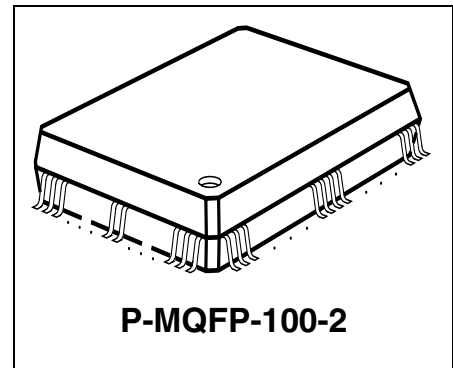

Type	Package
PEF 20450 / 20470 / 24470	P-MQFP-100-2

1.2 Features in Detail

Flexible Data Rates

Each input and each output line of the local bus is programmable to operate at different data rates. The possible data rates are 2.048 Mbit/s, 4.096 Mbit/s, 8.192 Mbit/s, and 16.384 Mbit/s.

Constant and Minimum Delay

Each connection independent of the addressed buses can be determined to be a constant delay or minimum delay connection. Constant delay means that any input time-slot or subchannel is available on the programmed output after 2 frames. Minimum delay means that the time-slot or subchannel appears at the output as soon as possible. The minimum delay depends on the chosen connections and the possible range is between 0 and 2 frames.

Subchannel Switching

Each connection can be a 1-bit, 2-bit, 4-bit, or 8-bit connection. Subchannel switching has a constant delay of 2 frames. Subchannel switching is supported only for data rate of 2.048 Mbit/s, 4.096 Mbit/s and 8.192 Mbit/s.

Programmable Clock Shift

The position of time-slot 0 of each local bus input line can be programmed within the time-slot before and after the PFS rising edge in half bit steps. Also the position of time-slot 0 of all local bus output lines can be programmed within the first time-slot after the PFS rising edge.

Automatic Data Rate Adaption

Connections are also possible between lines operating at different data rates. The programmer just specifies input and output line, time-slot, and if necessary, the subchannel.

Parallel Mode

The first 8 local bus input and output lines can be configured to one parallel input or output port respectively. In serial mode a time-slot is determined by 8 consecutive data clock cycles according to each line. In parallel mode a time-slot is determined by 1 data clock cycle according to the first 8 lines.

PRELIMINARY**Overview****Broadcast**

With this feature it is possible to distribute one incoming time-slot to different output time-slots.

Multipoint

Multipoint connections can be seen as the opposite of broadcast connections. Here it is possible to generate one output time-slot consisting of several input time-slots. The specified input time-slots are logically AND or OR connected (selectable) and have a constant delay of 2 frames.

Read Access

The programmer has access to any input time-slot. After issuing an appropriate command the arrival of the time-slot will be reported by interrupt. The value can be read from a dedicated register. For every read request the command has to be issued again.

Message Mode (Write Access)

This feature allows a constant value to be sent to any given output time-slot.

Framing Group

It is possible to specify up to 8 different framing signals of 8 kHz. The position of the rising edge and the pulse width can be programmed for each signal. The reference frame is determined by the PFS signal. The pulse parameters are programmed in half step resolution according to a 16.384 MHz clock.

General Purpose Clocks

All 8 GPCLK lines can be configured as individual clock outputs with 8 kHz, 2.048 MHz, 4.096 MHz, 8.192 MHz, 16.384 MHz and for test purposes with the internal frequency or the input frequency of the analog PLL (APLL).

GPIO Port

Each line of the general purpose input/output port can be configured to be either input or output. According to an input an edge causes an interrupt. The outputs can be influenced by write access via the microprocessor interface. Thus the user has the possibility to observe and influence additional signals for his application.

Microprocessor Interface

All devices provide a standard 8-bit microprocessor interface operating in either Intel or Motorola mode. Optionally it is possible to configure the GPIO port as additional data lines to provide a 16-bit microprocessor interface. The use of the 16-bit μ P interface

PRELIMINARY**Overview**

reduces the number of write cycles required to configure a connection from 7 (in case of 8-bit μ P interface) to 3 write cycles.

Input/Output Tolerance

The MTSI can be used in a 5 V environment. Inputs and outputs are 3.3 V and 5 V tolerant. The outputs have TTL level driving capability.

1.3 Logic Symbol

The MTSI is a pure PCM switch and provides 16 PCM input lines and 16 PCM output lines.

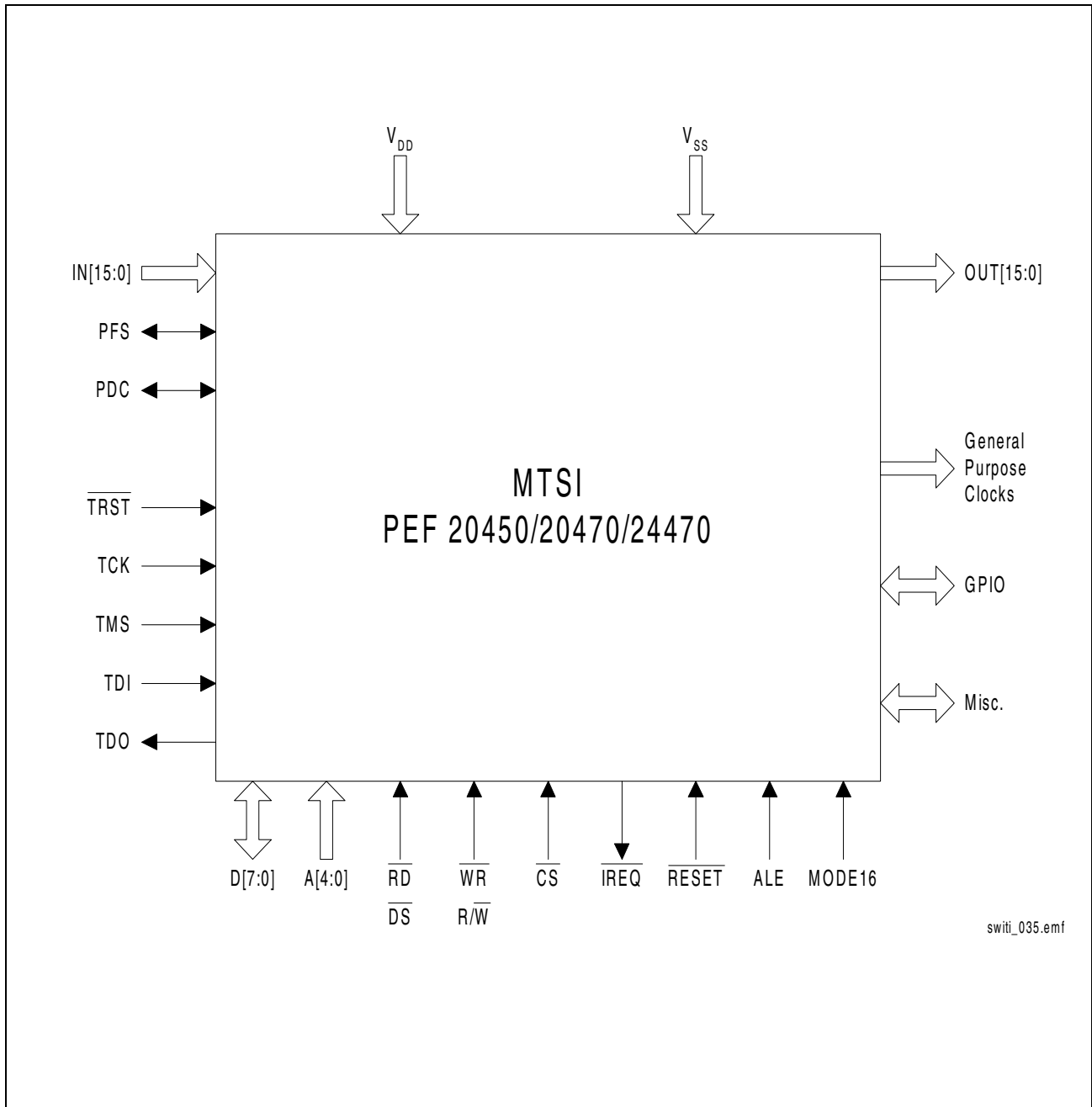

Figure 1 Logic Symbol

1.4 Standard PBX or CO Application

The MTSI or the HTSI in M-Mode can be used, just as the MTSC or MTSL, in standard private branch exchange or central office applications (**Figure 2**), e.g. in the switching network.

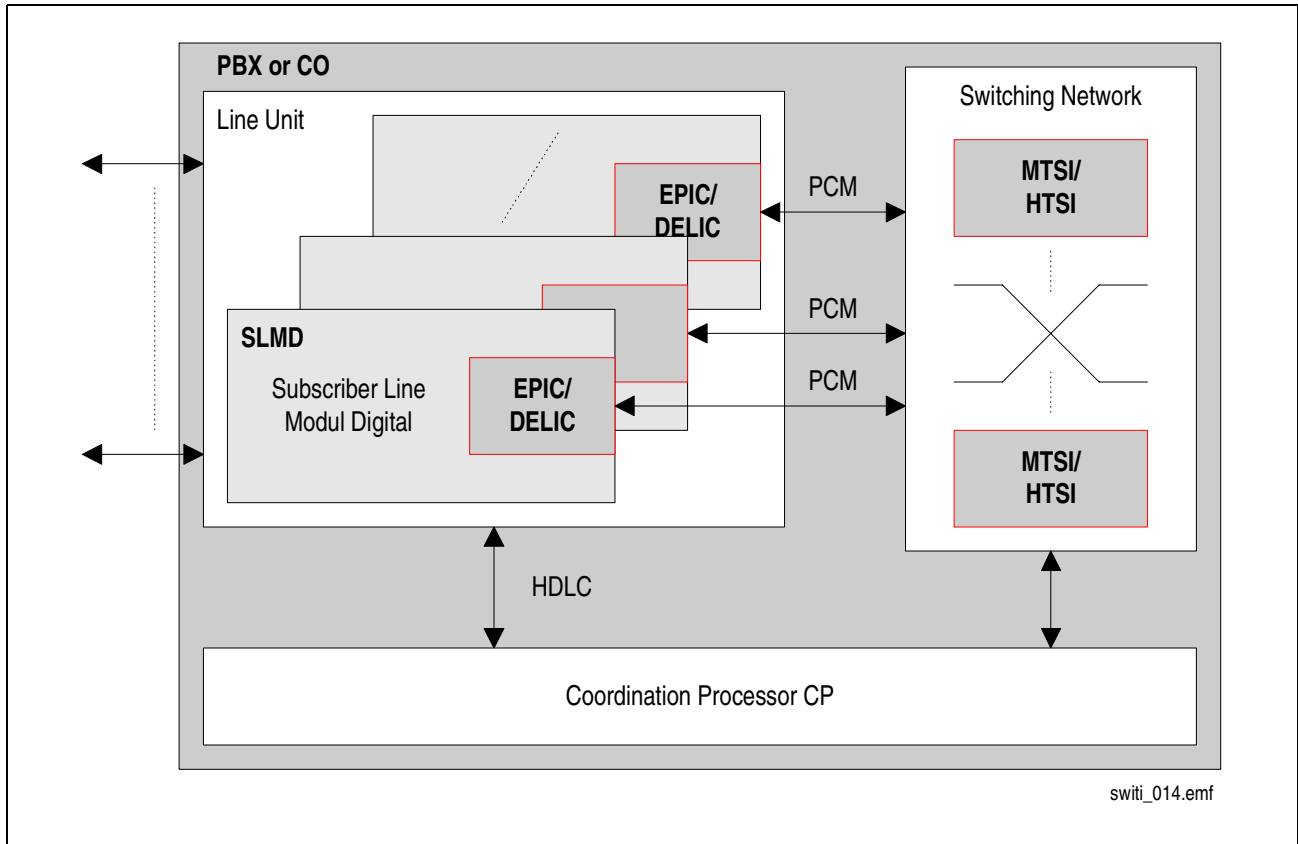

Figure 2 Standard PBX or CO Application

2 Pin Description

The pin description gives an overview of the pin numbers, names, direction, position and function ordered by the different interfaces.

Note: All unused input or I/O pins should be connected to V_{SS} to avoid leakage current.

2.1 Pin Diagrams

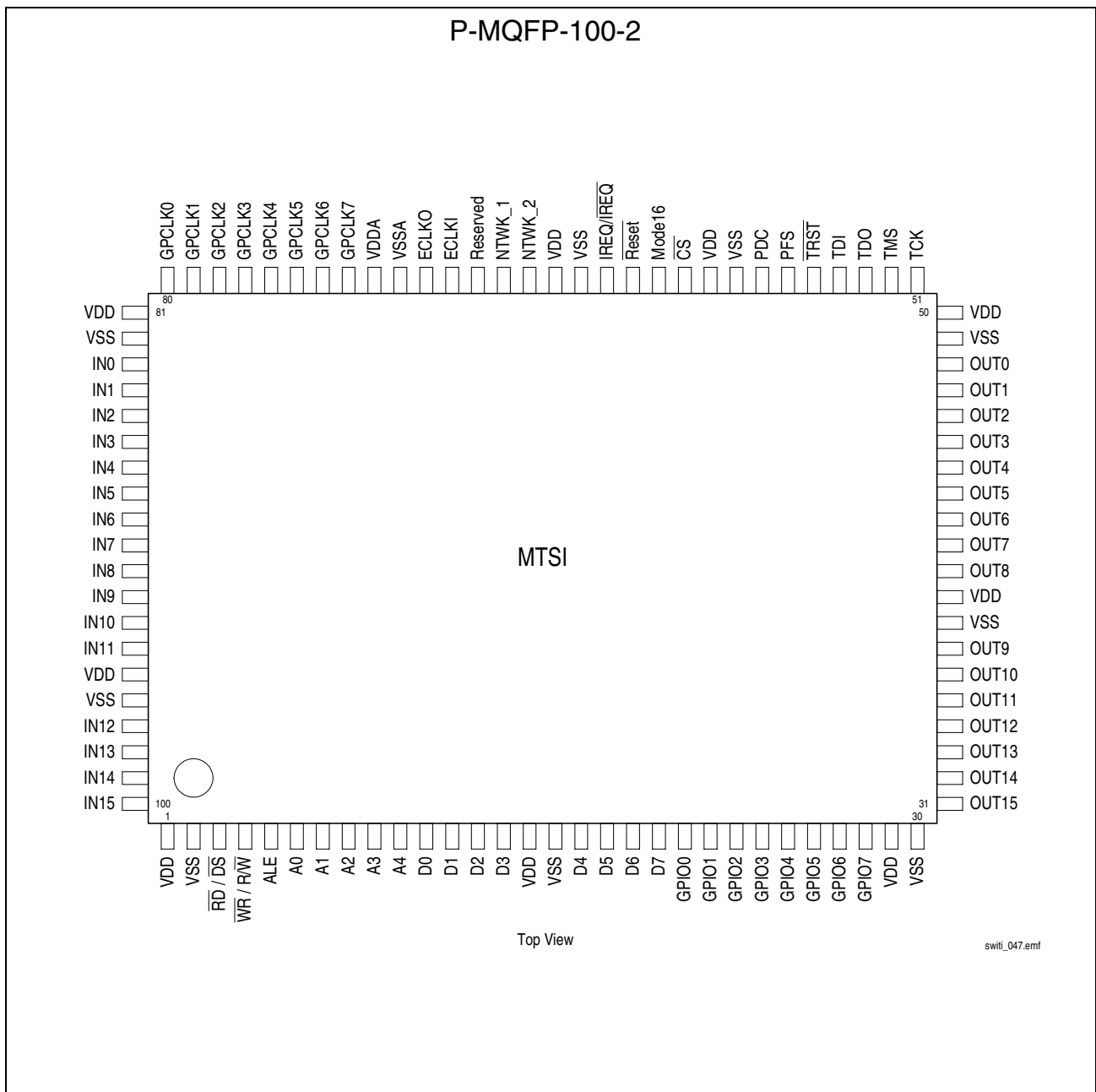

Figure 3 Pin Configuration

PRELIMINARY

Pin Description

2.2 Pin Definitions and Functions

2.2.1 Local Bus Interface (PCM)

Table 3 Local Bus Interface

Pin No.	Symbol	In (I) Out (O)	Function	Reset Behavior
56	PFS	I/O	PCM Frame Synchronization Clock of 8 kHz	High Z
57	PDC	I/O	PCM Data Clock of 2.048 Mbit/s, 4.096 Mbit/s, 8.192 Mbit/s, 16.384 Mbit/s	High Z
100-97, 94-83	IN[15:0] ¹⁾	I	PCM Receive Data Port 15 to 0	
31-37, 40-48	OUT[15:0] ²⁾	O	PCM Transmit Data Port 15 to 0	High Z

1) 100 is IN15, 99 is IN14, 98 is IN13..

2) 31 is OUT15, 32 is OUT14, 33 is OUT13..

2.2.2 General Purpose Port

Table 4 GPIO

Pin No.	Symbol	In (I) Out (O)	Function	Reset Behavior
28-21	GPIO[7:0] ¹⁾	I/O	General Purpose I/O port (only if 8-bit μ P interface used)	Input
	D[15:8]		Upper 8 bit of 16-bit μ P interface	

1) 28 is GPIO7, 27 is GPIO6, 26 is GPIO5..

2.2.3 Clock Signals

Table 5 Clock Pins

Pin No.	Symbol	In (I) Out (O)	Function	Reset Behavior
69	ECLKI	I	External Crystal Input of 16.384 MHz, or 32.768 MHz External Oscillator Input of 16.384 MHz, or 32.768 MHz	
70	ECLKO	O	External Crystal Output of 16.384 MHz, or 32.768 MHz	
73-80	GPCLK[7:0] ¹⁾	O	General Purpose Clock Output (Framing Signals)	High Z

PRELIMINARY

Pin Description

Table 5 Clock Pins (cont'd)

Pin No.	Symbol	In (I) Out (O)	Function	Reset Behavior
67	NTWK_1	I	Primary Network Timing Reference Input Optionally the PLL can be synchronized to this input which can be 8 kHz, 512 kHz, 1.536 MHz, 1.544 MHz, 2.048 MHz	
66	NTWK_2	I	Secondary Network Timing Reference Input Optionally the PLL can be synchronized to this input which can be 8 kHz, 512 kHz, 1.536 MHz, 1.544 MHz, 2.048 MHz	

¹⁾ 73 is GPCLK7, 74 is GPCLK6, 75 is GPCLK5..

2.2.4 JTAG Interface

Table 6 JTAG Interface

Pin No.	Symbol	In (I) Out (O)	Function	Reset Behavior
51	TCK	I	Test Clock Single rate test data clock.	
52	TMS	I	Test Mode Select A '0' to '1' transition on this pin is required to step through the TAP controller state machine.	
55	TRST	I	Test Reset Resets the TAP controller state machine (asynchronous reset).	
53	TDO	O	Test Data Out In the appropriate TAP controller state test data or a instruction is shifted out via this line.	High Z
54	TDI	I	Test Data Input In the appropriate TAP controller state test data or a instruction is shifted in via this line.	

2.2.5 Microprocessor Interface

Table 7 Microprocessor Interface

Pin No.	Symbol	In (I) Out (O)	Function	Reset Behavior
60	\overline{CS}	I	Chip Select Active low. A "low" on this line selects all registers for read/write operations.	
3	\overline{RD} \overline{DS}	I	Read (Intel/Infineon Mode) Indicates a read access. Data Strobe (Motorola Mode) During a read cycle, DS indicates that the device should place valid data on the bus. During a write access, DS indicates that valid data is on the bus.	

PRELIMINARY

Pin Description

Table 7 Microprocessor Interface (cont'd)

Pin No.	Symbol	In (I) Out (O)	Function	Reset Behavior
4	\overline{WR} $R\overline{W}$	I	Write (Intel/Infineon Mode) Indicates a write access. Read/Write (Motorola Mode) Indicates the direction of the data transfer on the bus.	
5	ALE	I	Address Latch Enable Controls the on-chip address latch in multiplexed bus mode. While ALE is 'high', the latch is transparent. The falling edge latches the current address. ALE is also evaluated to determine the bus mode (ALE fix 'low' = Motorola, fix 'high' = Intel/Infineon)	
61	MODE16	I	Microprocessor Bus 8/16-Bit Interface Selection ('low' = 8 bit, 'high' = 16 bit)	
63	$\overline{IREQ}/$ \overline{IREQ}	O OD	Interrupt Request This pin is programmable to push/pull (active high or low) or open-drain. This signal is activated when SWIT1 requests an μ P interrupt. When operated in open drain mode, multiple interrupt sources may be connected.	High Z
10-6	A[4:0] ¹⁾	I	Address Bus When operated in address/data multiplex mode, the address pins are externally connected to the D bus.	
20-17, 14-11	D[7:0] ²⁾	I/O	Data bus	Input
62	\overline{RESET}	I	System Reset SWIT1 is forced to go into reset state.	

1) 10 is A4, 9 is A3, 8 is A2..

2) 20 is D7, 19 is D6, 18 is D5..

2.2.6 Power Supply

Table 8 Power Supply Pins

Pin No.	Symbol	In (I) Out (O)	Function
1,15, 29,39, 50,59, 65,81, 95	V _{DD}	I	Power Supply 3.3 V
2,16, 30,38, 49,58, 64,82, 96	V _{SS}	I	Digital Ground (0 V)
72	V _{DDA}	I	Power Supply Analog Logic 3.3 V Used for PLL
71	V _{SSA}	I	Analog Ground (0 V)
68	R		Reserved. Must be connected to ground

3 Architectural Description

The following sections give a short overview of the functionality of the SWITL.

3.1 Functional Block Diagram

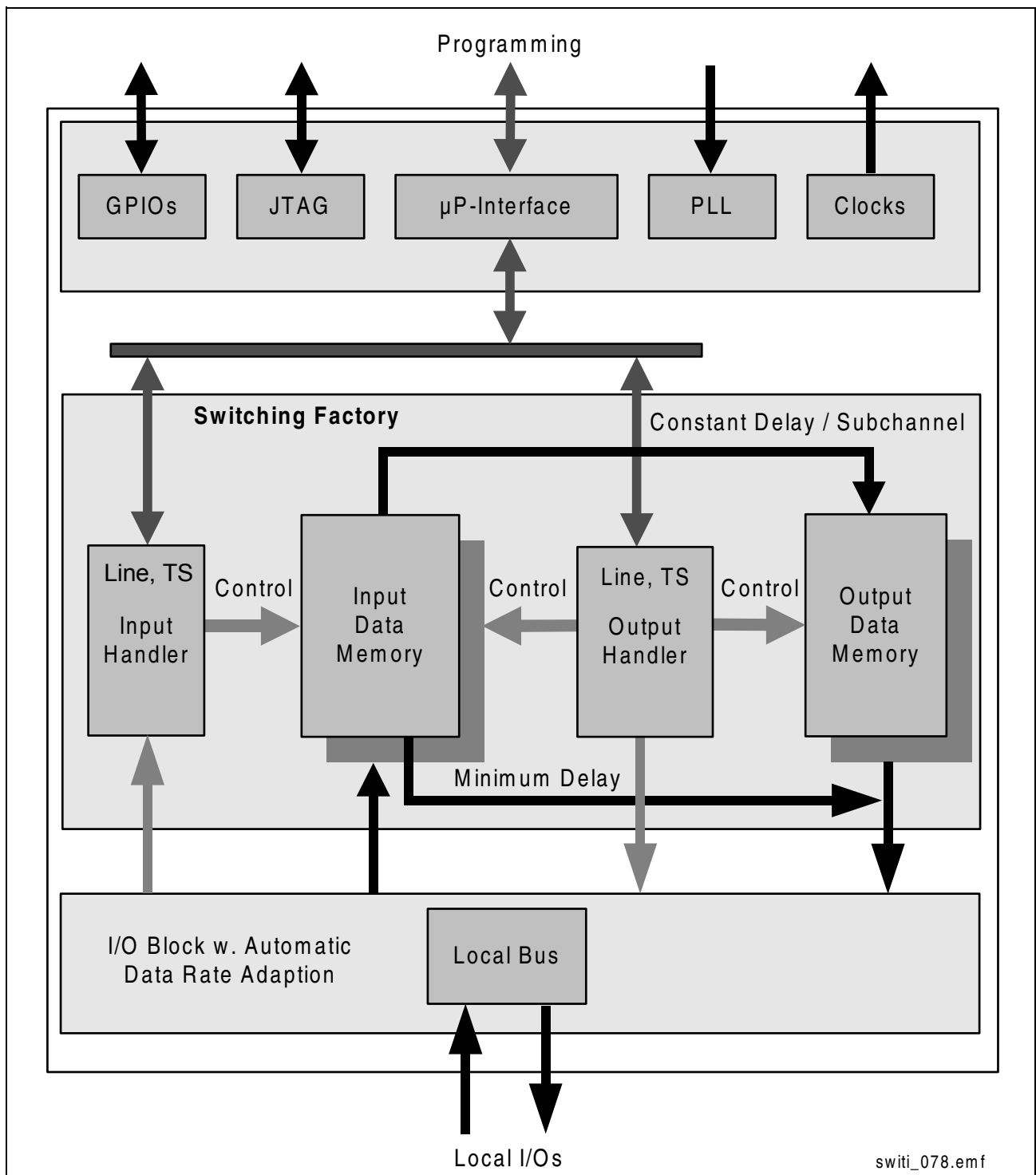

Figure 4 Block Diagram

3.2 Overview of Functional Blocks

Switching Factory

The switching factory is responsible for transferring and handling the incoming data streams to the assigned output channels and time-slots. The block includes a 512, 1024, or 2048 byte input and output data memory as well as an input and output connection memory.

Local bus I/O Block

The block is designed to handle the conversion of the data provided via the switching block and the external local bus (PCM) interface. It performs the PCM timing, the data rate selection and the tristate control.

Microprocessor Interface Block

A standard 8-bit multiplexed or de-multiplexed μ P interface is provided, compatible to Intel/Infineon Tech. (e.g. 80386EX, C166) and Motorola (e.g. 68040, 68340, 68360, 801) bus systems. If the GPIO port is not needed it can be used to provide a 16-bit μ P interface.

GPIO Block

This block supports up to 8 external port lines each one configurable as input or output. A change on an input line may cause an interrupt (if not masked). The user has access to the port configuration and information via the appropriate registers of the μ P interface.

PLL and Clock Block

The PLL generates all frequencies supporting the local bus (PCM). The internal phase-locked loop (PLL) generates all bus frequencies synchronized to a selected reference signal. The output frequency tolerance is equal to the input frequency tolerance. The PLL operates from a 16.384 MHz, or 32.768 MHz external crystal, oscillator.

3.3 Switching Factory

As shown in [Figure 4](#) the switching factory comprises the input/output data memory and the input/output data handler with the programmed connections. The I/O controller handles all lines operating at the same or different data rate. To establish a connection the user must only program the source line with time-slot and the destination line with the time-slot. The internal controller (data handler) writes the connection in a connection descriptor list and stores this list in the connection data handler. The programming procedure is described in [Chapter 6](#). The incoming time-slot will be stored in the input data memory controlled by the input handler. The output handler controls the constant, minimum delay and subchannel switching.

3.3.1 Switching Modes

The SWITI family supports a various number of switching modes. All modes are described in the following chapters.

3.3.1.1 Minimum and Constant Delay

Each connection independent of the addressed buses can be determined to be a constant delay or minimum delay connection. Constant delay means that any input time-slot or subchannel is available on the programmed output after 2 frames. Minimum delay means that the time-slot appears at the output as soon as possible. The minimum delay depends on the chosen connections and the possible range is between 0 and 2 frames, up to 3 frames in rare cases.

An application note which describes the possible connection and minimum delays is available.

3.3.1.2 Subchannel Switching

Subchannel switching has a constant delay of 2 frames. Every connection can be 1-bit, 2-bit, 4-bit, or normal 8-bit connection. It is possible to combine every kind of subchannel connection, e.g. two 1-bit time-slots with one 4-bit time-slot to one output time-slot. Please refer to [Chapter 6.10.2](#) for a detailed description about the programming.

3.3.1.3 Multipoint Switching

As described in the overview the multipoint-switching allows to switch several input time-slots to one output time-slot. All input data are logical AND or OR connected. This mode is selectable with the multipoint connection command. The setup (logical AND or OR) for the last connection determines all other previous programmed multipoint connections. Multipoint switching has always a constant delay. Subchannel switching is not supported.

3.3.1.4 Broadcast Switching

Broadcast switching allows to distribute one incoming time-slot to different output time-slots. The input and output mechanism is the same as the normal constant delay connection mode with subchannel switching. Minimum delay is also supported without subchannel switching.

A table with the possible connections and minimum delays will be provided.

The broadcast connection is programmed in the same way as a normal connection. The output time-slots can be released with the disconnect part of broadcast command. The last connection must be released with the normal disconnect command.

Subchannel Broadcast

It is possible to program one input time-slot as broadcast subchannel connections. That means the bits from the input time-slot are used in several broadcast connections related to one or more output time-slots.

The output time-slots must be released with the disconnect part of broadcast command. The last subchannel connection must be released with the normal disconnect command. (Please refer to [Chapter 6.10.4](#) for an example)

3.3.1.5 Bidirectional Switching

Bidirectional switching allows to install very easily a symmetrical bidirectional connection ([Figure 5](#)). The input and output mechanism is the same as the normal constant delay or minimum delay connection. The time to program a bidirectional connection is twice as the time to program a normal connection since the internal state machine has to calculate the belonging connection. There is a special command to program a bidirectional connection. A bidirectional connection can only be programmed on an available time-slot and input/output line.

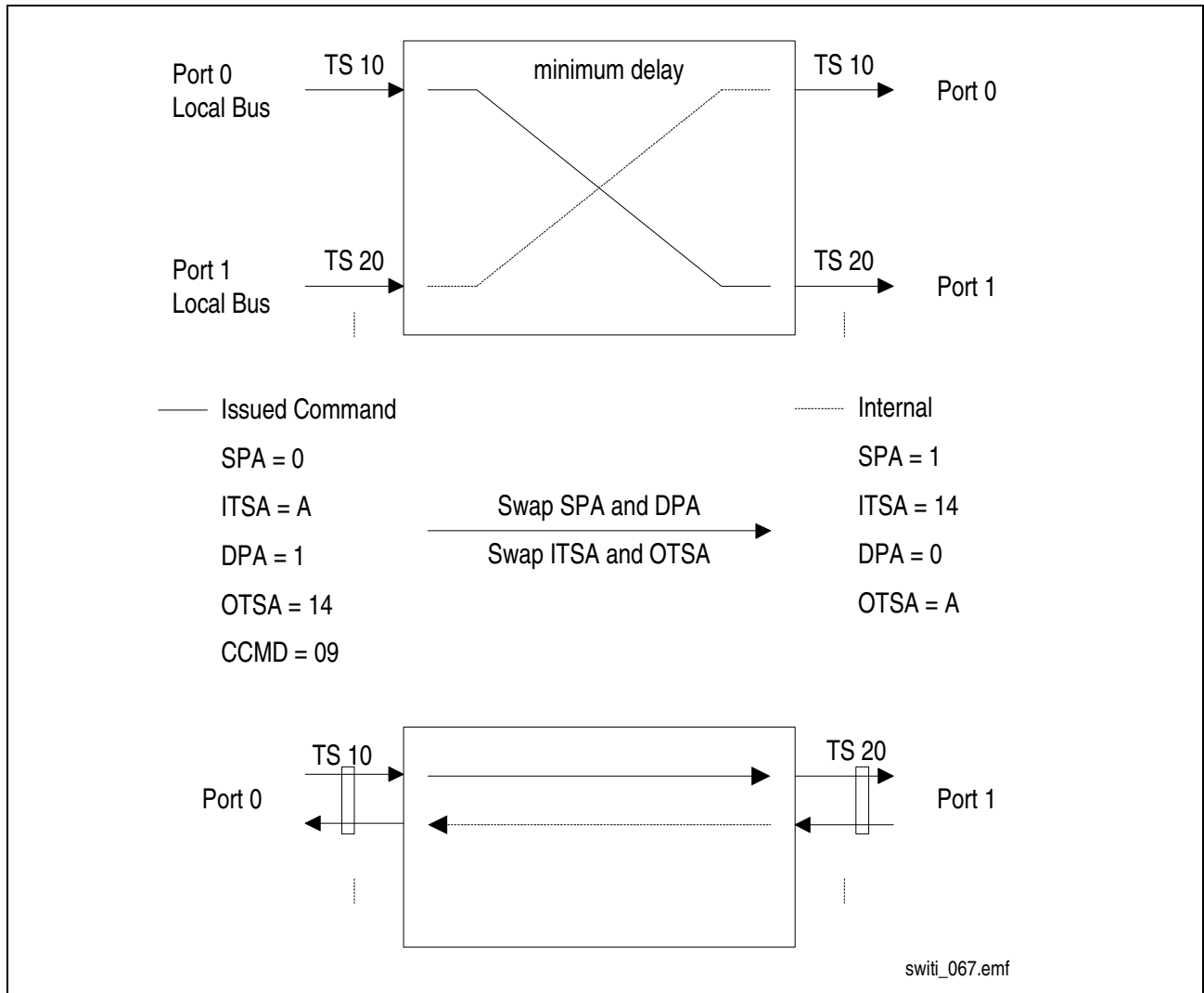

Figure 5 Bidirectional Mode

3.3.1.6 Message Mode

The message mode allows to send a predefined 8-bit data value in a defined time-slot on a dedicated destination port. Message mode is started or stopped via register **CCMD**. The data value to be send is predefined in register **MV**. The time-slot and the destination port is is defined in register **OTSA** and register **DPA**.

3.3.2 Parallel Mode for Local Bus

The parallel mode can be set with the 'set parallel mode' command in the configuration command register. This command set the first 8 input lines and the first 8 output lines of the local bus as parallel bus. If the parallel mode is enabled all included lines will be set to 2.048 Mbit/s automatically. If the parallel mode is disabled all lines will keep the data rate of 2.048 Mbit/s until a new data rate will be programmed for the selected line.

The internal S/P-converter is bypassed. The 8 bit data stream per time-slot is distributed on 8 data lines, one bit for every line. The least significant bit is assigned to line 0 and the most significant bit is assigned to line 7. To program a connection line 0 must be used for this special parallel data port. The bit shift value must only be programmed for port 0 and this value will be assigned to the other 7 ports automatically. The initialize sequence is described in [Chapter 6](#).

The switching data handling is the same as the data handling for constant delay or minimum delay mode. A timing diagram is provided in the timing diagram chapter ([“PCM Parallel Mode Timing” on page 104.](#)).

3.3.3 Switching Block Error Handling

The normal procedure to establish a connection is explained in [Chapter 6](#). The way to program a new connection for a specific time-slot and data line is to release the connection and to program the new connection. The SWITI switching concept provides an internal error handling to detect errors in the switching chain caused by a programming error. A programming error can occur because of noises on the data lines, software errors, etc.

A programming error is defined as follows:

- if a non existing connection (minimum, constant delay, or message) will be released.
- or if an existing minimum delay connection will be established.

If a programming error or a connection memory overflow is detected the interrupt bit CON in the [IESTA2](#) register will be set. In this case the last connection which has been tried to establish or to release is not valid. The operation of the switching device is not affected and will be continued without any restrictions.

For debug purposes the SWITI has the capability to write out the content of the complete connection memory and data memory via the microprocessor interface. This procedure is described in [Chapter 3.3.4](#).

It is recommended to track all established and connections with the specific customer application software. For debug purpose it is useful to compare the contents of the switching memory with the virtual connections in the application software.

3.3.4 Analyze Connection and Data Memory

With the special command "memory dump enable" in the connection command register ([CCMD](#)) it is possible to read the complete memory in a defined sequence from the [CON](#) register with a 8-bit μ P access. This feature can be used only for analyze purposes.

The command disables the complete switching function as far as all data lines are set to high impedance. If the command is set and after the specific recovery time (200 ns) the connection chain and data memory can be read sequentially by a μ P access to the [CON](#) register. The internal controller writes the next 8-bit memory data in the [CON](#) register if

PRELIMINARY

Architectural Description

the μP read access is finished. That means there is a specific recovery time for the μP to the next **CON** read access.

The internal memory dump controller reads the present memory contents of the input chain memory, data memory and output chain memory. During the memory dump the internal state machine will lose the synchronization with the external frame structure. Therefore a software reset must be issued and the device must be programmed again, except the clock configuration.

Infineon Technologies provides a software driver to recalculate the chain and to recover the current connections.

3.4 Clock Generator and PLL

3.4.1 General Overview

The following figure gives an overview about the clock generator with the integrated PLL.

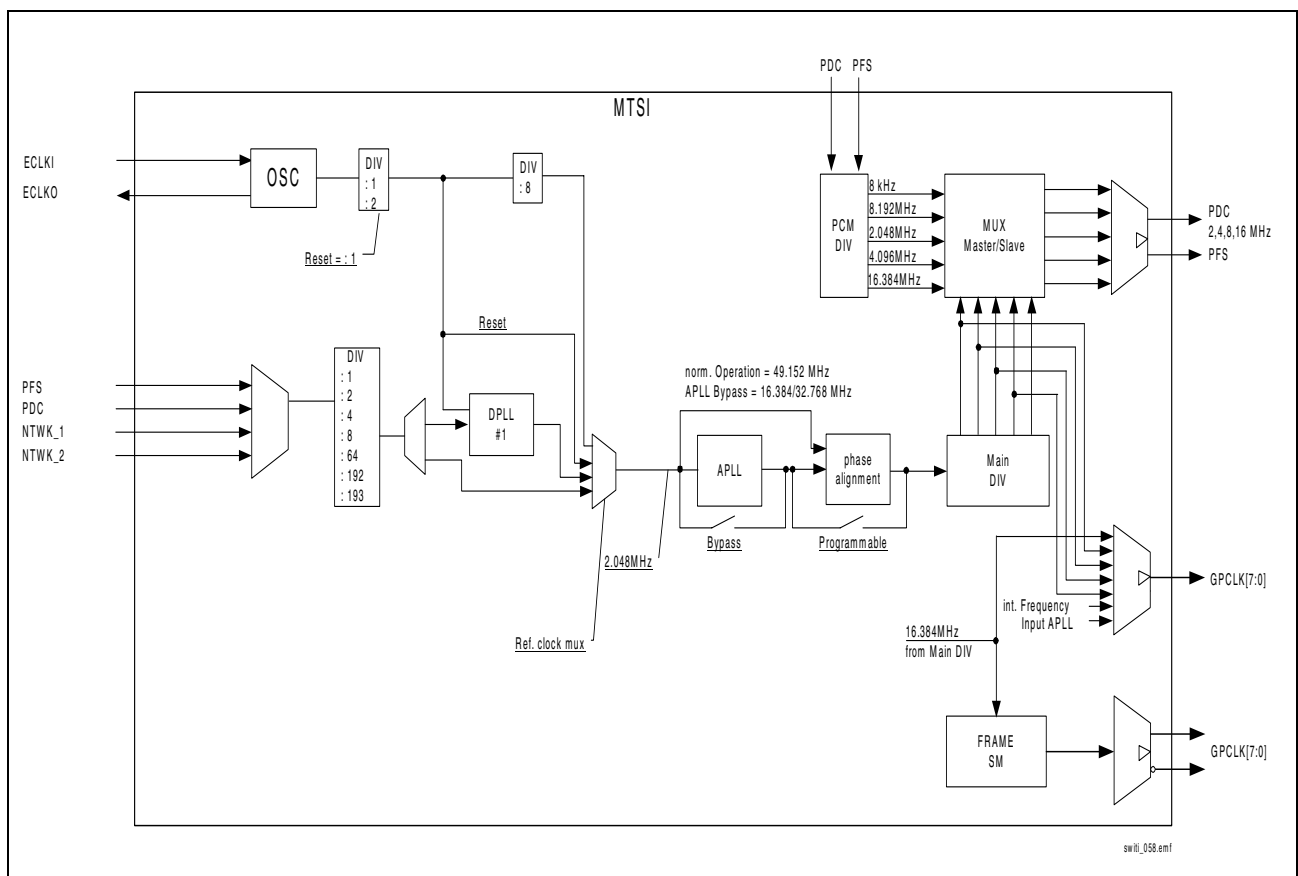

Figure 6 SWITI Clock Generator

The SWITI clock generator provides all necessary clock signals for the MTSI local bus (PCM) interface. Since the device is a PCM clock master capable device there is one digital PLL which can be locked to different network reference signals (< 2.048 MHz).

PRELIMINARY**Architectural Description**

The digital PLL synchronizes the external crystal or oscillator to the selected reference clock. The digital PLL (DPLL) will be bypassed if the selected reference signal is ≥ 2.048 MHz. The input signal for the analog PLL (APLL) is 2.048 MHz in normal operation mode. The APLL is used for multiplying the 2.048 MHz clock into a 49.152 MHz clock and to generate all clock signals for the PCM, and general purpose clock signals.

The SWITI has an on-chip oscillator which allows the user to connect an external 16.384 MHz or 32.768 MHz crystal. Instead of using the crystal it is possible to assign a 16.384 MHz, or 32.768 MHz oscillator to the ECLKI pin.

After the power-on or hardware reset the APLL is bypassed. The APLL will be synchronized (after approximately 750 μ s) to the external crystal or external oscillator if the command 'set external frequency' is set. This command must be used otherwise the internal working frequency is equal to the external input frequency and the SWITI will not work properly. If the APLL is locked the status bit 'APLL' in the **ISTA1** register will be set.

Note: After the reset it is necessary to program the correct crystal or oscillator value as first programming step. Otherwise the operation frequency for the SWITI is not correct.

3.4.2 Analog PLL (APLL)

Features

- Low cycle-to-cycle jitter < 1 ns
- Natural frequency $f_g = 15$ kHz
- Damping factor = 0.7
- Input Frequency = 2.048 MHz in any case
- Output Frequency = 49.152 MHz, duty-cycle = 50 %
- Rule behavior = change of output frequency in range of 0 - $\pm 10\%$ in response to changes of input frequency
- phase slope of output frequency equal to phase slope of input frequency

Note: It is necessary to provide a "noise free" analog power (V_{DDA}/V_{SSA}) to reduce the internal jitter of the APLL. These pins must be decoupled from the digital power (V_{DD}/V_{SS}), see also the available Application Note "Layout Notes".

3.4.2.1 Functional Description

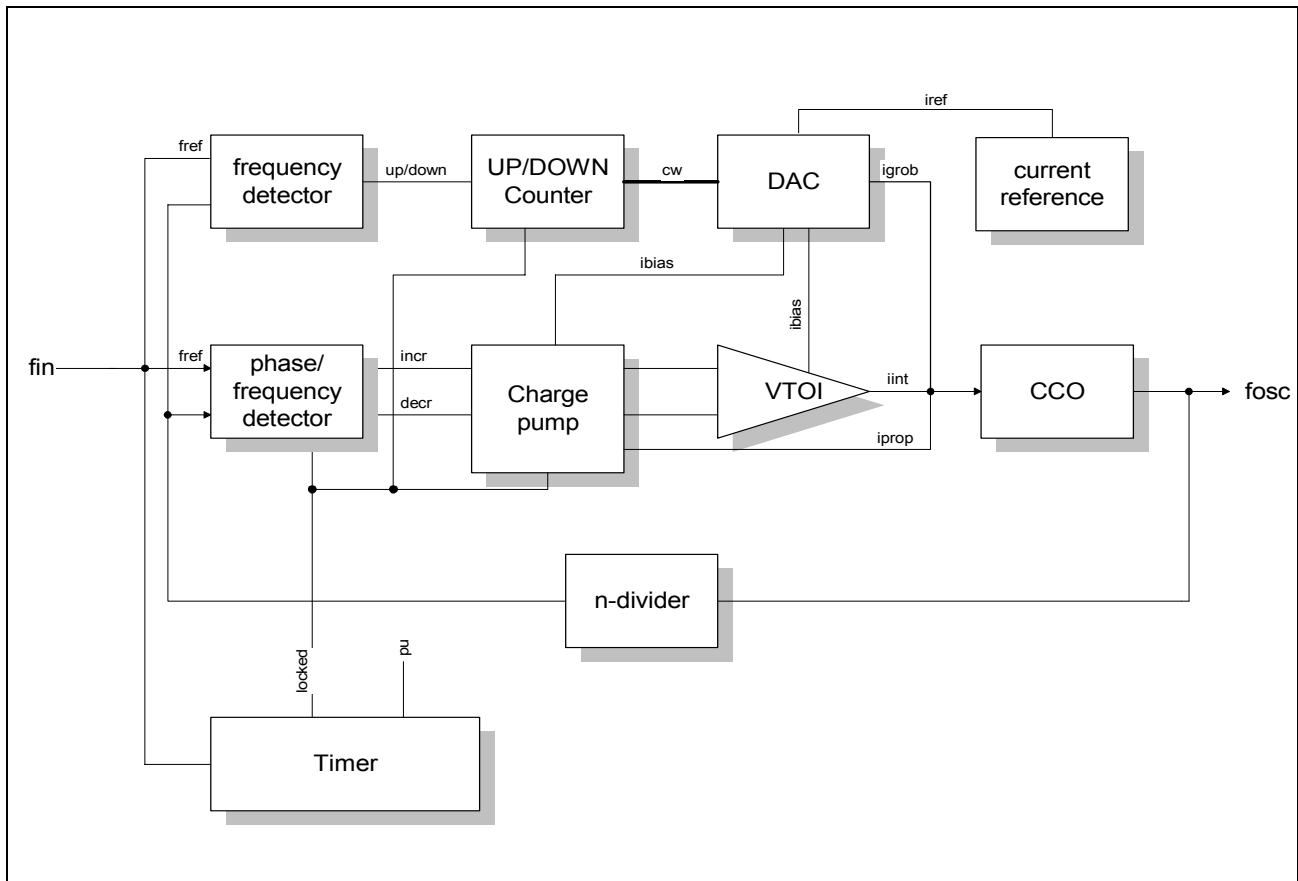

Figure 7 Block Diagram of APLL

The value of the output frequency depends of the programming of the n-divider. The chosen output frequency for the SWIT1 is 49.152 MHz and the input frequency is 2.048 MHz.

The macro consists of a digital and an analog PLL which are working together. During start-up only the digital one is enabled and makes a coarse adjustment, so that the technology dependency of the circuit is compensated. Afterwards the digital PLL is disabled again and the analog one is switched on for normal operation.

The digital PLL is of first order and consists of a frequency detector (FD), an up/down counter, a digital-to-analog converter (DAC) and a current controlled oscillator (CCO). The FD detects any frequency difference between the reference clock (f_{ref} : input clock $f_{in} = 2.048$ MHz) and the divided oscillator clock. The output signal controls the counter. If the reference frequency is higher than the divided oscillator frequency the counter is increased. The counter output drives a current steering DAC which controls the input current of the internal oscillator. Its current rises and the output frequency increases until both frequencies are equal.

PRELIMINARY**Architectural Description**

The digital PLL is enabled after reset or power up and is disabled after 750 μ s (lock time of PLL). The counter keeps its value and the DAC output current **irough** is constant until the digital PLL is reseted.

The second order analog PLL consists of a phase/frequency detector (PFD), a charge pump (CP), a loop filter and the CCO.

The PFD which is sensitive to the rising edge detects any phase or frequency difference between the input clock (**fref**) and the divided output clock (**feedback**) and generates a control signal proportional to the phase difference. The output signals **up** and **down** cause the charge pump to modulate the amount of charge in the low pass filter (VTOI) for the integral part (**iint**) and to feed current into the CCO for the proportional part (**iprop**). With these two currents and the DAC output **irough** the CCO is controlled. If **feedback** is leading **fref**, the oscillator is too fast. The **down** signal is activated and the CP subtracts some current **iprop**. When **fref** is in phase with the **feedback** the PLL will hold the control current at that level and phase lock will be achieved. Thus through this negative feedback arrangement, the PLL causes the **feedback** and **fref** signals to be equal with minimum phase offset. If the analog PLL becomes unstable, a signal **pllko** is generated which resets the digital PLL.

3.4.2.2 Jitter Transfer Function

Jitter transfers or jitter attenuation refers to the magnitude of jitter at the output of a device for a given amount of jitter at the input of the device. Input jitter is applied at various amplitudes and frequencies, and output jitter is measured with various filters depending on the applicable standards.

Figure 8 shows the jitter transfer function of the SWITl device. The cutoff frequency of the integrated low pass filter is $f_g = 15$ kHz.

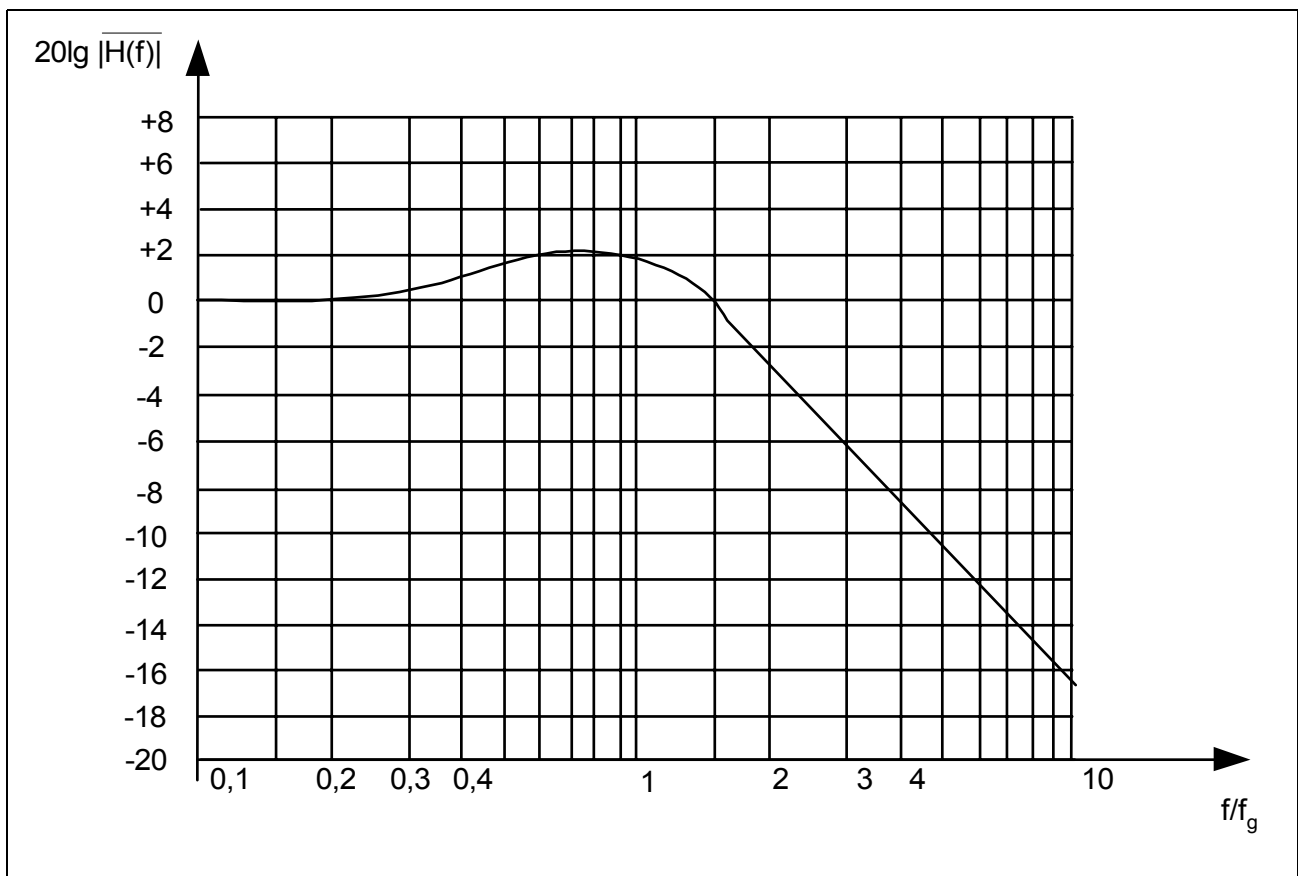

Figure 8 APLL - Jitter Transfer Function

3.4.3 Phase Alignment

If the phase alignment function is enabled all PLL output signal and the main divider are edge synchronized with the PLL clock input. If the selected reference signal is less than 2.048 MHz the edge synchronization resolution depends on the selected external crystal/oscillator frequency. If the phase alignment function is disabled the PLL output frequency (49.152 MHz) is edge synchronized with the PLL input frequency and the main divider output frequencies are edge synchronized with PLL output frequency.

An example of phase alignment functionality is shown in **Figure 9**.

Phase alignment is required to keep the output signals in phase relative to the input signals. After reset phase alignment is automatically activated in slave mode and turned off in master mode.

Note: The phase alignment should be disabled for all reference frequencies < 2.048 MHz.

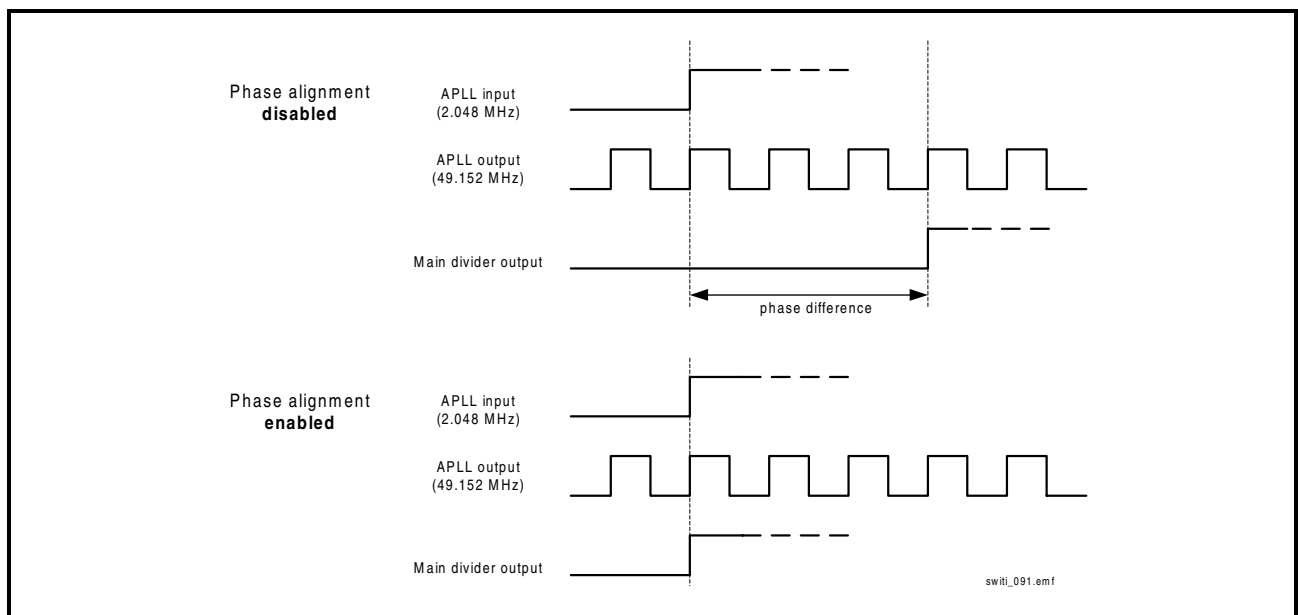

Figure 9 Example of Phase Alignment

3.4.4 PLL Synchronization

The PLL reference source can be selected from the primary reference master source (PFS, PDC, NTWK_1/_2). If the selected reference signal is less than 2.048 MHz the main digital PLL is used to synchronize the analog PLL. The digital PLL is sourced from the external oscillator, or crystal. In this case the analog PLL output frequency tolerance is equal to the external oscillator/crystal frequency tolerance.

Furthermore the analog PLL can be sourced directly from the external oscillator, or crystal, or from the PDC input. All generated output frequencies will have the same tolerance as the selected input frequency.

3.5 Loops

The loop command in the configuration command register **CMD2** provides support for automatic PCM-PCM loops.

All input lines are pad connected with the corresponding output line.

After the loop disable command was set the lines will be set in high-impedance after approximately two frames.

3.6 Read SWITI Configuration with Indirect Register Addressing

Since the SWITI configuration can be programmed with defined instructions in the **CMD1** and **CMD2** registers it is possible to read the current configuration through the indirect access registers. The indirect addressing is started by writing one of the five read configuration commands in the **CMD2** register. The five commands can be separated in two groups, internal configuration and external line configuration. The internal configuration, e.g. clock generator, IREQ pin can be read with the command "Read Configuration". The internal settings are decoded with the instruction bits I3..0. The data rate for the PCM interface can be read with the "Read Local Bus (PCM) Line Configuration" command. The "Read GPCLK Configuration" and "Read Bit/Clock Shift Configuration" must be issued to get the GPCLK line configuration and the bit shift value. The **TSV** and **CON** registers contain the required information after the internal read process is complete. The recovery time is 240 ns. To read the correct configuration data from the **TSV** register it is not allowed to use the command "Read Time-Slot Value" before the **TSV** register has been read.

3.7 Power-On and Reset Behavior

3.7.1 Hardware Reset

There are two independent low active reset pins: $\overline{\text{RESET}}$ and $\overline{\text{TRST}}$.

If the $\overline{\text{RESET}}$ pin is activated, it immediately sets all outputs and I/O ports into tri-state, except the ECLKO pin. After the reset process the correct external frequency must be set with the command 'Set external frequency' accordingly. This command starts the configuration process for the APLL. The APLL is locked after 750 μs . During this period the APLL is bypassed and the internal frequency is 2.048 MHz. If the APLL is locked the internal frequency will be 49.152 MHz.

Individual output sections must be enabled by setting the command in the configuration command register **CMD1**, or **CMD2**. Internally all state machines, counters and registers are cleared and set to their defined reset value.

The $\overline{\text{RESET}}$ pin doesn't control the boundary scan register and TAP-controller. If the $\overline{\text{TRST}}$ pin is asserted the TAP-controller will go into the Test-Logic-Reset state and all boundary scan elements are bypassed. All outputs and I/O-pins are controlled by the core logic and are tristated according to the programmed functionality or the core reset condition (pin $\overline{\text{RESET}}$).

The hardware reset must be issued for a minimum of 1 μs , for more details please refer to the chapter "[Hardware Reset Timing](#)" on page 112.

3.7.2 Software Reset

The software reset is accomplished by setting the 'Set Software Reset' command in the **CMD2** register. The software reset clears the complete device except the clocking unit and the temporary microprocessor registers (e.g. **CMD1**).

The software reset can be deactivated with the 'Set Software Reset' command. During the software reset the microprocessor interface doesn't accept any other commands for a minimum of 1 μs .

4 Description of Interfaces

4.1 Local Bus Interface (PCM)

The local bus is a PCM interface consisting of input and output data lines (IN, OUT), a PCM data clock PDC and a frame synchronization signal PFS.

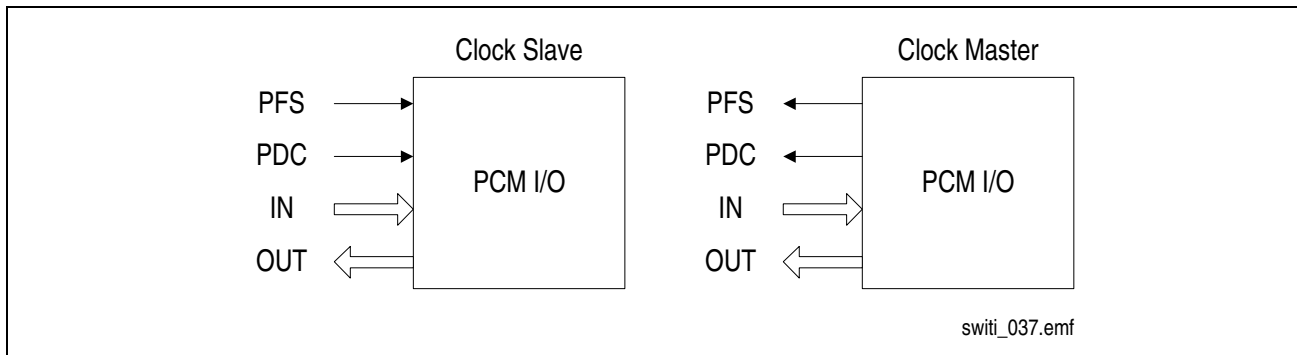

Figure 10 PCM Interface Configurations

The **PFS Frame Sync** is a 8 kHz signal and delimiting the frame. This input signal is used by the SWITI to determine the start of a frame. A frame is divided into 8-bit wide time-slots. The amount of time-slots within a frame depends on the selected data rate of PDC which can be 2.048 Mbit/s, 4.096 Mbit/s, 8.192 Mbit/s, 16.384 Mbit/s. The PFS input has a Schmitt-Trigger characteristic.

The **PDC Data Clock** input supplies the SWITI with a data clock. It can be operated with 2.048 MHz, 4.096 MHz, 8.192 MHz, or 16.384 MHz data rate clock depending on the selected **highest** data mode. The PDC clock signal must be equal or higher as the highest data rate. The PDC input has a Schmitt-Trigger characteristic.

A clock slave **must receive** PFS and PDC whereas a clock master **drives** these signals. To enable or disable the signals for the clock master the command 'PCM Clock Input/Output Selection' must be issued.

The time-slots are transmitted and received via 16 input and 16 output lines (**IN[15:0]**, **OUT[15:0]**). The input lines have a Schmitt-Trigger characteristic. The output lines have tristate outputs with push-pull characteristic. For every time-slot not participating to a connection the output is high impedance.

With the special command "Local Bus (PCM) Standby" in the **CMD2** register it is possible to set all PCM lines in a high impedance state during the normal operation mode. All PCM lines are in high impedance state after the reset process and must be enabled with the "Local Bus (PCM) Standby" command. All lines which are not participating on a switching operation are in high impedance state and the time-slot information on the input lines are discarded automatically.

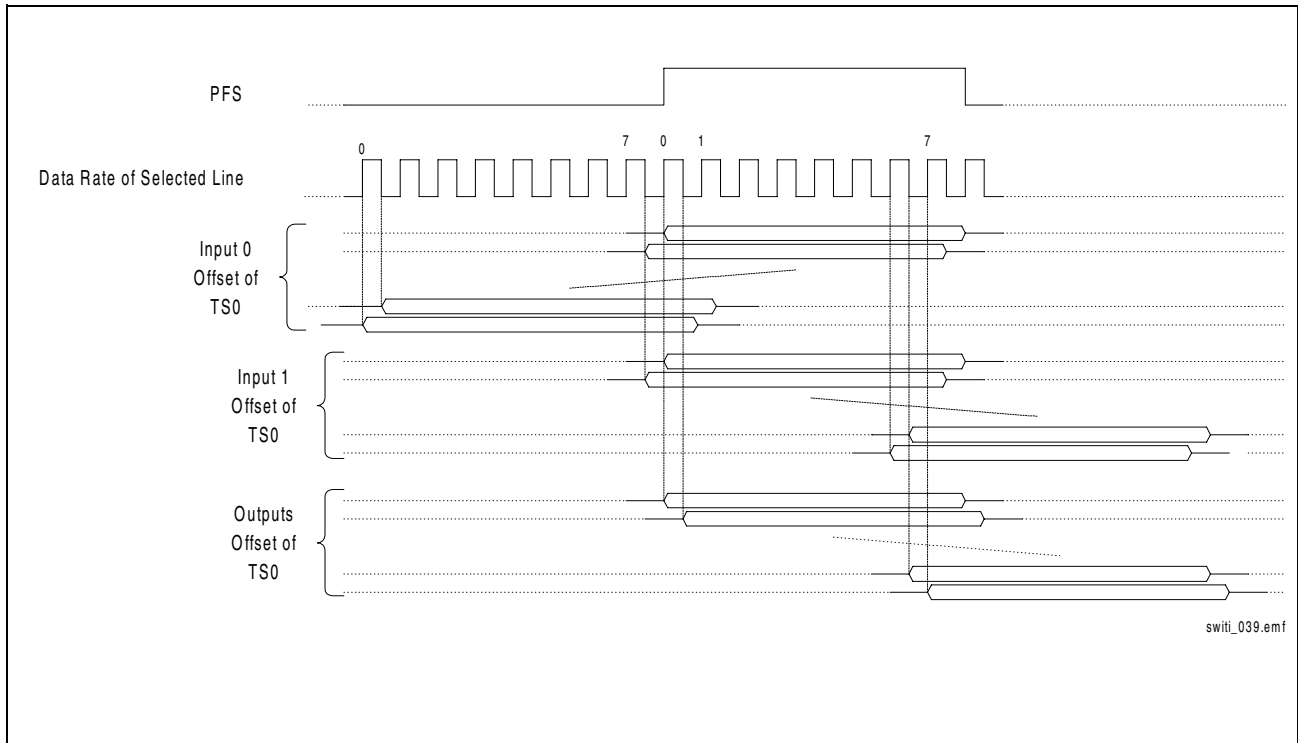

Figure 11 PCM Bit Shifting

For **each** PCM input line the offset of time-slot zero can be adjusted in a range from 0 to 7 bit in half clock resolution before or after the PFS rising edge. For **all** output lines the offset of time-slot zero can be adjusted in a range from 0 to 7 bit in half clock resolution after the PFS rising edge.

The resolution depends on the selected data rate that means the resolution doesn't depend on the PDC signal.

After the reset process the bit shift is disabled for all lines. That means the time-slot 0 starts with the rising edge of PFS. All input data will be sampled with falling edge of the selected data rate and the output data are valid with the rising edge of the selected data rate.

4.2 Data Rate

The MTSI provides the programming of different data rates for all data lines. All local bus lines can operate with 2.048 MHz, 4.096 MHz, 8.192 MHz, and 16.384 MHz having data rates of 2.048 Mbit/s, 4.096 Mbit/s, 8.192 Mbit/s and 16.384 Mbit/s.

The input and output lines are independent of each other, i.e. for a given bus line the input and the output lines can be programmed with different data rates.

The maximum aggregate data rate supported at the input and output bus lines is 262.144 Mbit/s, with all lines operating at 16.384 Mbit/s (i.e. 16 lines x 16.384 Mbit/s per line = 262.144 Mbit/s, as input and/or output).

4.3 Microprocessor Interface

A standard 8-bit multiplexed or non-multiplexed μ P interface is provided. It is compatible to Intel/Siemens (e.g. 80386EX, C166) or Motorola (e.g. 68040, 68340, 68360, 801) bus systems. If the GPIO port is not needed it can be used to provide a 16-bit μ P interface. The 16-bit mode is determined according to MODE16 input pin.

MODE16 = '0' -> 8-bit interface

MODE16 = '1' -> 16-bit interface

This chapter describes how to configure the μ P interface to each mode.

4.3.1 Intel/Siemens or Motorola Mode

The Intel/Siemens or Motorola mode for the μ P interface can be configured during the hardware reset process in conjunction with the ALE pin.

- ALE permanently driven to 'low' => Motorola mode
- ALE permanently driven to 'high' => Intel/Siemens mode
- Edge on ALE => Intel/Siemens multiplexed mode

A falling or rising edge on ALE during the normal operation selects the multiplexed mode immediately. With the hardware reset and the tied ALE pin it is possible to return to the Motorola or Intel/Siemens mode.

4.3.2 De-multiplexed or Multiplexed Mode

In both modes, the A-bus and the D-bus are used in parallel. The A-bus should be connected to the LSBs of AD-bus, coming from the μ P, also in multiplexed mode.

The next figure describes the connection to the address and data buses in the different modes.

Note: Motorola mode is used only with de-multiplexed AD bus. Intel/Siemens mode may be used with both, multiplexed or de-multiplexed AD bus.

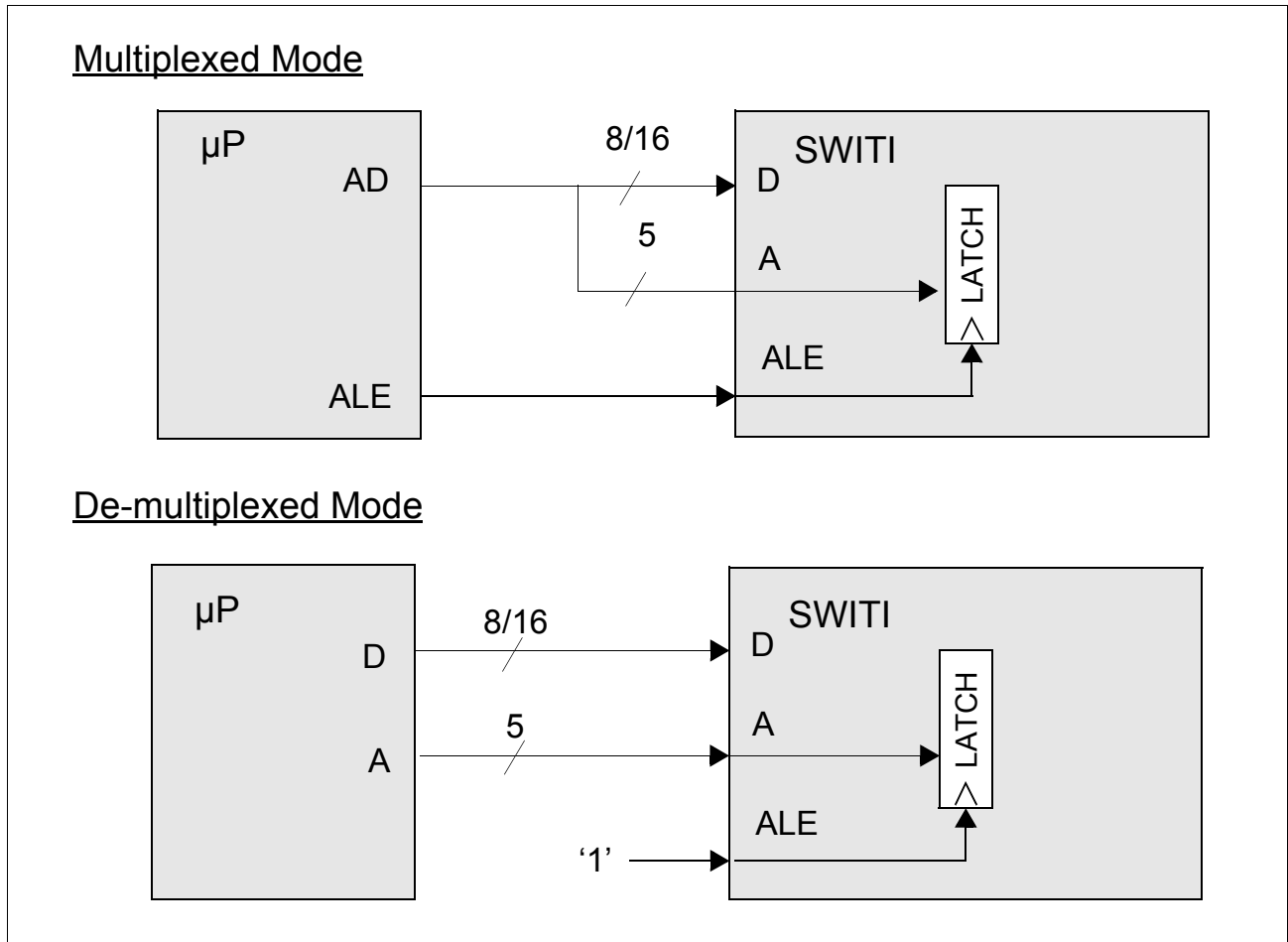

Figure 12 Multiplexed and in De-multiplexed Bus Mode

Note: In both modes only the 5 LSBs of A-bus or AD/bus are connected to the Address inputs.

4.4 General Purpose Port (GPIO)

This port consists of 8 lines each one configurable as input or output. A change on an input line may cause an interrupt (if not masked). The user has access to the port configuration and information via the appropriate registers of the μ P interface.

Figure 13 shows an example.

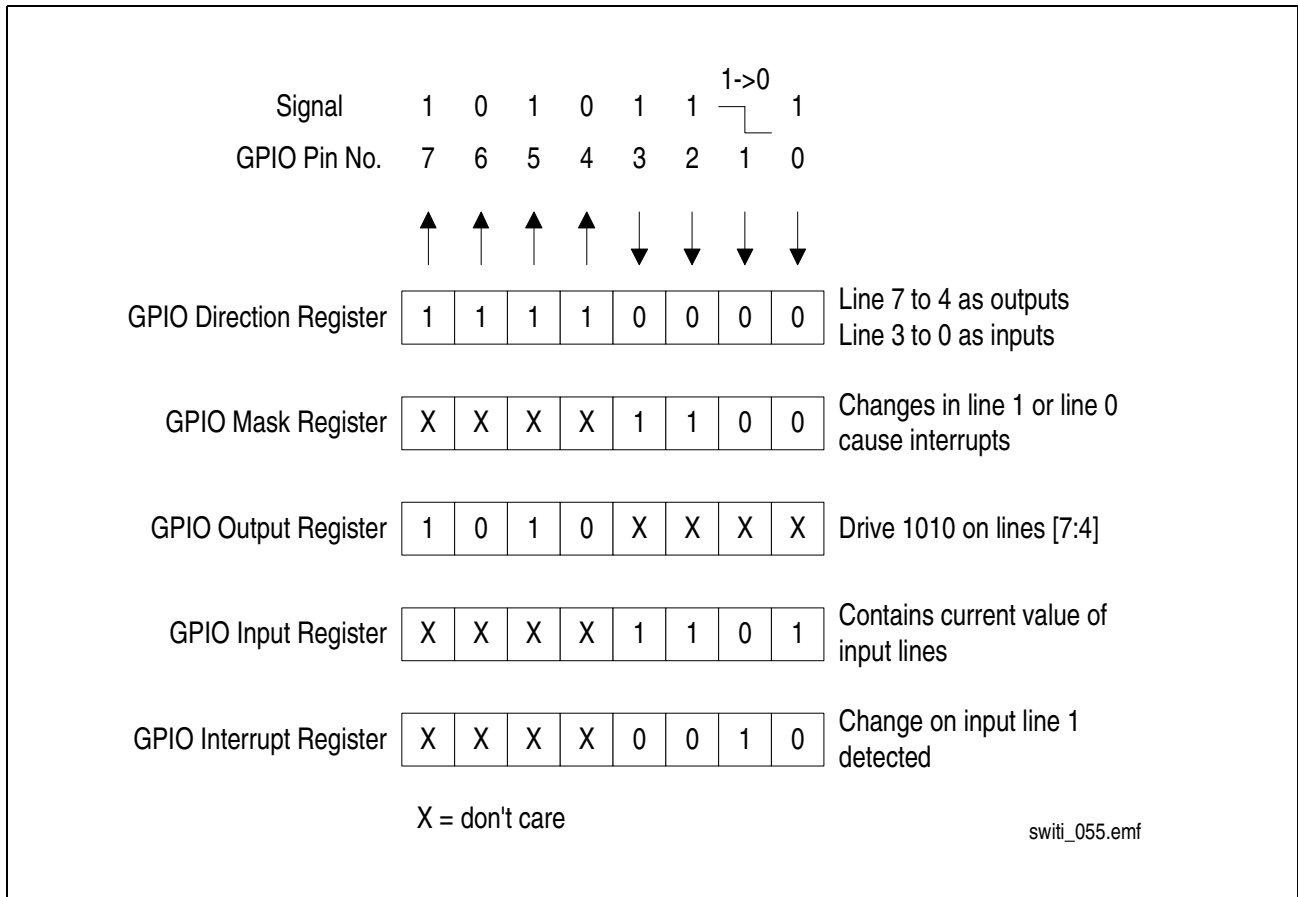

Figure 13 GPIO Port Configuration Example

4.5 General Purpose Clocks

The SWITI provides 8 general purpose clock lines. With two independent commands in the **CMD2** register the lines can be configured as frame group signals or individual clock signals. The last written command for a line is valid and controls the multiplexer.

4.5.1 Frame Group Outputs

Via 8 output lines it is possible to provide 8 different framing signals which are used for synchronization purpose. All signals have a period of 125 μ s. Their offset can be programmed individually within the PFS determined frame in a resolution of 61 ns (i.e. 1/16.384 MHz). The default start point for the offset is the beginning of a frame (rising edge of PFS and the clock signal). The start point for the offset can be shifted for an half clock cycle, that means the second start point is determined with the rising edge of PFS and the next falling edge of the clock signal (as shown in [Figure 14](#)). The high time of the signal can also be programmed in steps of 61 ns. All frame signals can be controlled as high or low active.

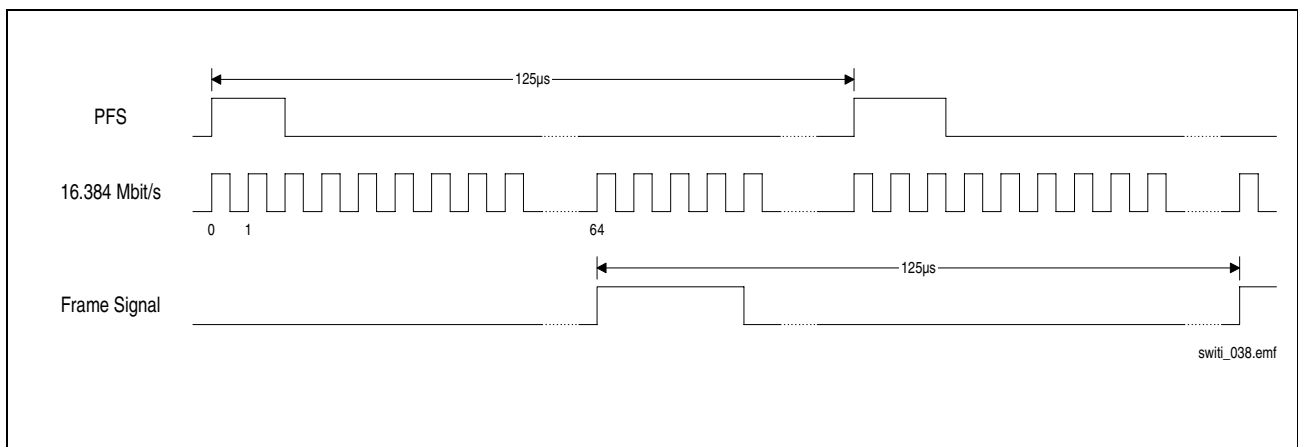

Figure 14 Frame Signal Example

[Figure 14](#) shows an example of a frame signal beginning with the rising edge of the 64th clock cycle with a length of 4 clock cycles. Further programming examples can be found in [Chapter 6.8.1](#).

4.5.2 GPCLK as Clock Outputs

All 8 GPCLK lines can be configured as individual clock outputs with 8 kHz, 2.048 MHz, 4.096 MHz, 8.192 MHz, 16.384 MHz and for test purposes with the internal frequency or the input frequency of the analog PLL (APLL). All clock signals are generated from the analog PLL output frequency which is the internal frequency. The quality of all output frequency signals depends on the quality of the selected input PLL frequency.

4.6 JTAG (Boundary Scan)

The SWITI provides a fully IEEE 1149.1 compatible boundary scan support consisting of:

- a complete boundary scan chain
- a Test Access Port controller (TAP controller)
- five dedicated pins: TCK, TMS, TDI, TDO and a $\overline{\text{TRST}}$ to asynchronously reset the TAP controller
- one 32-bit IDCODE register

4.6.1 Boundary Scan

All pins except power supply and crystal are included in the boundary scan. Depending on the pin functionality one (input), two (output, enable) or three (input, output, enable) boundary scan cells are provided.

The maximum clock rate at pin TCK is 10 MHz.

4.6.2 Test-Access-Port (TAP)

The following signal pins allow the boundary scan test logic to be accessed:

- TCK
 - Test Clock input to which a central BSc test clock is applied. This BSc test clock is independent of the system clock. Clock phases are derived from this clock for test sequence control.
- TMS
 - Test Mode Select control input for which the desired status changes at the TAP controller by applying a certain level (0/1) caused by the rising edge of TCK.
- TDI
 - Test Data Input whose data is inserted into the test logic with the rising edge of the TCK.
- TDO
 - Test Data Output with tristate capability which is only active during the SHIFT-IR and SHIFT-DR controller state, and whose data is driven with the falling edge of TCK.

4.6.3 TAP Controller

The Test Access Port (TAP) controller implements the state machine defined in the JTAG standard IEEE 1149.1.

Transitions on the pin TMS cause the TAP controller to perform a state change. The possible instructions are listed in the following table.

Table 9 TAP Controller Instructions

Code	Instruction	Function
0000	EXTEST	External testing
0001	IDCODE	Reading ID code
0100	HIGHZ	High impedance state of all boundary scan outputs
0101	SAMPLE/PRELOAD	Snap-shot testing
0110	INTEST	Internal testing
0111	CLAMP	Reading outputs
1111	BYPASS	Bypass operation

The instruction length is four bit.

EXTEST is used to verify the board interconnections.

When the TAP controller is in the state “update DR”, all output pins are updated with the falling edge of TCK. When it has entered state “capture DR” the levels of all input pins are latched with the rising edge of TCK. The in/out shifting of the scan vectors is typically done using the instruction **SAMPLE/PRELOAD**.

INTEST supports internal chip testing.

When the TAP controller is in the state “update DR”, all inputs are updated internally with the falling edge of TCK. When it has entered state “capture DR” the levels of all outputs are latched with the rising edge of TCK. The in/out shifting of the scan vectors is typically done using the instruction **SAMPLE/PRELOAD**.

SAMPLE/PRELOAD

The **SAMPLE/PRELOAD** instruction enables all signal pins (inputs and outputs) to be sampled during operation (**SAMPLE**) and the result to be shifted out through the shift BSc register. The function of the internal logic is not influenced by this instruction. While shifting out, the BSc cells can be serially loaded at the same time with defined values through TDI (**PRELOAD**). The **SAMPLE/PRELOAD** instruction selects the boundary scan register in normal mode. In state **CAPTURE-DR** data is loaded into the boundary scan register with the rising edge of TCK. In state **UPDATE-DR** the contents of the boundary scan register are written into the second register stage of the boundary scan

PRELIMINARY

Description of Interfaces

register. This data become effective at the outputs only if an instruction has been activated that sets the BSc register to test mode: e.g. EXTEST or CLAMP.

IDCODE

The 32-bit identification register is serially read out via TDO. It contains the version number (4 bits), the device code (16 bits) and the manufacturer code (11 bits). The LSB is fixed to '1'..

Version	Device Code	Manufacturer Code	Output
xxxx	xxxx xxxx xxxx xxxx	xxxx xxxx xxx	1 --> TDO

Table 10 Boundary Scan IDCODE

	Version	Device Code	Manufacture Code	Bit0
MTSI	0010	0000 0000 0110 1001	0000 1000 001	1
MTSI-L	0010	0000 0000 0110 1010	0000 1000 001	1
MTSI-XL	0010	0000 0000 0110 1011	0000 1000 001	1

CLAMP

The BSc register is in test mode. For the duration of the CLAMP instruction, the BYPASS register is selected so that a minimal shift path is created.

During SHIFT-DR data can be shifted through the BYPASS register. The contents of the BSc register does not change during the UPDATE-DR state.

HIGHZ

The HIGHZ instruction disables all outputs if switched to high impedance state. The outputs are switched to high impedance in state UPDATE-IR. The outputs are redefined according to the next new instruction if another instruction has become active with UPDATE-IR. The selected test data register is the BYPASS register.

BYPASS

A bit entering TDI is shifted to TDO after one TCK clock cycle, e.g. to skip testing of selected ICs on a printed circuit board.

4.7 Identification Code via μ P Read Access

The SWITL offers two possibilities to read the identification code.

- via the JTAG port as described in [Chapter 4.6](#)
- or via the processor interface

After a hardware reset the identification code is stored in the [General Purpose Interrupt Register \(GPI\)](#) and can be read via the processor interface. The high nibble is the version number and the low nibble is equal to the low nibble of the device code shown in [Table 11](#). For the 8-bit μ P interface configuration the first write access to the General Purpose Mask Register ([GPM](#)) will reset the register [GPI](#) to 00_H. If the μ P interface is configured as a 16-bit interface the IDCODE can always be read from the [GPI](#) register, that means the [GPI](#) register will not be reset.

The IDCODE for the μ P read access is shown in [Table 11](#).

Table 11 IDCODE via μ P Read Access

	8-Bit IDCODE (MSB..LSB)	
	Version	Device Code
MTSI	0010	1001
MTSI-L	0010	1010
MTSI-XL	0010	1011

Note: The version number of the IDCODE register remains unchanged.

5 Register Description

The register description gives information about all registers accessible via the microprocessor interface according to address, short name, access, reset value and value range.

5.1 Register Overview For 8-Bit Interface
Table 12 Register Overview For 8-Bit Interface

Reg Name	Access	8-bit Address	Reset Value	Comment	Page No.
SPA	RD/WR	00 _H	00 _H	Source Port Address Register Value range see Table 13	42
ITSA	RD/WR	01 _H	00 _H	Input Time-Slot Address Register Value range see Table 14	42
DPA	RD/WR	02 _H	00 _H	Destination Port Address Register Value range see Table 13	42
OTSA	RD/WR	03 _H	00 _H	Output Time-Slot Address Register Value range see Table 14	43
SCA	RD/WR	07 _H	00 _H	Subchannel Address Register Value range see Table 15	43
GI1	RD/WR	04 _H	00 _H	General Input Register 1	44
GI2	RD/WR	05 _H	00 _H	General Input Register 2	46
CCMD	RD/WR	06 _H	00 _H	Connection Command Register	47
CMD1	RD/WR	08 _H	00 _H	Configuration Command Register 1	49
CMD2	RD/WR	0A _H	00 _H	Configuration Command Register 2	52
MV	RD/WR	0C _H	00 _H	Message Value Register	56
ISTA1	RD	0E _H	00 _H	Interrupt Status Register 1	57
IESTA1	RD	10 _H	00 _H	Interrupt Error Status Register 1	58
IESTA2	RD	11 _H	00 _H	Interrupt Error Status Register 2	58
INTM1	RD/WR	12 _H	3D _H	Interrupt Mask Register 1	59
INTEM1	RD/WR	14 _H	3F _H	Interrupt Error Mask Register 1	60
INTEM2	RD/WR	15 _H	FF _H	Interrupt Error Mask Register 2	60
GPPI	RD	16 _H	00 _H	General Purpose Port Input Register	61
GPPO	WR	18 _H	00 _H	General Purpose Port Output Register	61
GPD	RD/WR	1A _H	00 _H	General Purpose Direction Register	61
GPM	RD/WR	1B _H	FF _H	General Purpose Mask Register	62
GPI	RD	1C _H	IDCODE	General Purpose Interrupt Register	62
TSV	RD	1E _H	XX _H	Time-Slot Value Register	63
CON	RD	1F _H	XX _H	Configuration Register	66

PRELIMINARY

Register Description

Table 13 Value Range for SPA/DPA

Addressed Lines	Value Range Bit3..0
Local bus input lines	15..0

Table 14 Value Range for ITSA/OTSA

Data Rate	Number of available time-slots (Bit7..0)
2.048 Mbit/s	31..0
4.096 Mbit/s	63..0
8.192 Mbit/s	127..0
16.384 Mbit/s	255..0

Table 15 Value Range for SCA

Mode	Range
1-bit switching	0..7 for ISCA0..2; 0..7 for OSCA0..2
2-bit switching	0..3 for ISCA0..1; 0..3 for OSCA0..1
4-bit switching	0..1 for ISCA0; 0..1 for OSCA0

5.2 Detailed Register Description For 8-bit Interface

Source Port Address Register RD/WR Address: 00H

Reset value: 00H

	7	6	5	4	3	2	1	0
SPA	0	0	0	0	PA3	PA2	PA1	PA0

BIT7..4 Must be set to 0

PA3..0 Port Address

Input Time-Slot Address Register RD/WR Address: 01H

Reset value: 00H

	7	6	5	4	3	2	1	0
ITSA	TSA7	TSA6	TSA5	TSA4	TSA3	TSA2	TSA1	TSA0

TSA7..0 Time-Slot Address

Destination Port Address Register RD/WR Address: 02H

Reset value: 00H

	7	6	5	4	3	2	1	0
DPA	0	0	0	0	PA3	PA2	PA1	PA0

BIT7..4 Must be set to 0

PA3..0 Port Address

PRELIMINARY

Register Description

Output Time-Slot Address Register RD/WR

Address: 03H

Reset value: 00H

	7	6	5	4	3	2	1	0
OTSA	TSA7	TSA6	TSA5	TSA4	TSA3	TSA2	TSA1	TSA0

TSA7..0 Time-Slot Address

Subchannel Address Register

RD/WR

Address: 07H

Reset value: 00H

	7	6	5	4	3	2	1	0
SCA	0	0	OSCA2	OSCA1	OSCA0	ISCA2	ISCA1	ISCA0

OSCA2..0 Output Subchannel Address

ISCA2..0 Input Subchannel Address

PRELIMINARY

Register Description

General Input Register 1

RD/WR

Address: 04H

Reset value: 00H

	7	6	5	4	3	2	1	0
GI1	GV7	GV6	GV5	GV4	GV3	GV2	GV1	GV0

GV7..0 General Value

In case of a PLL Reference Selection Command (CMD1) the content of this register is interpreted as follows:

GV2..0 Clock Frequency

- 000 = 8 kHz
- 001 = 512 kHz
- 010 = 1.536 MHz
- 011 = 1.544 MHz
- 100 = 2.048 MHz
- 101 = 4.096 MHz
- 110 = 8.192 MHz
- 111 = 16.384 MHz

In case of a Bit Shift Command (CMD1) the content of this register is interpreted as follows:

- GV4** Bit shift value (only for input lines)
 - 0 = bit shift applies before PFS rising edge
 - 1 = bit shift applies after PFS rising edge

GV3..1 Bit shift value (range: 7 to 0)

- GV0** Edge Control Bit (half clock shift)
 - 0 = data transmit with rising edge and is sampled with falling edge
 - 1 = data transmit with falling edge and is sampled with rising edge

PRELIMINARY**Register Description**

In case of the GPCLK as Frame Signal Command (CMD2) the content of this register is interpreted as follows:

- GV7..2** Offset within the PFS frame in number of 16.384 MHz clock cycles (lower 6 bits; refer to GI2 for the upper part)
- GV1** Edge Control Bit
 - 0 = data changes with rising edge and is sampled with falling edge
 - 1 = data changes with falling edge and is sampled with rising edge
- GV0** not used

In case of the GPCLK as Clock Signal Command (CMD2) the content of this register is interpreted as follows:

- GV2..0** Output Frequency for the selected line
 - 000 = 8 kHz
 - 001 = 2.048 MHz
 - 010 = 4.096 MHz
 - 011 = 8.192 MHz
 - 100 = 16.384 MHz
 - 101 = Input Analog PLL (2.048 MHz)
 - 110 = Internal Frequency (49.152 MHz)

PRELIMINARY

Register Description

General Input Register 2

RD/WR

Address: 05H

Reset value: 00H

	7	6	5	4	3	2	1	0
GI2	GV7	GV6	GV5	GV4	GV3	GV2	GV1	GV0

GV7..0 General Value

In case of the GPCLK as Frame Signal Command (CMD2) the content of this register is interpreted as follows:

GV7..5 Width of the pulse in number of 16.384 MHz clock cycles from 1 to 8
 i.e. GV7..5 = 000 => 1 clock cycle, GV7..5 = 010 => 3 clock cycles

GV4..0 Offset within the PFS frame in number of 16.384 MHz clock cycles (upper 5 bits; refer to GI1 for the lower part)

PRELIMINARY

Register Description

Connection Command Register

RD/WR

Address: 06H

Reset value: 00H

	7	6	5	4	3	2	1	0
CCMD	I3	I2	I1	I0	CC3	CC2	CC1	CC0

CC3..0 Command Code

0000 = no operation at all

0001 = Constant Delay Connection Command (incl. Broadcast Connection)
(SPA, ITSA, DPA, OTSA, SCA are considered)

I1..0 Subchannel Mode

00 = 8-bit wide time-slots

01 = 4-bit wide time-slots

10 = 2-bit wide time-slots

11 = 1-bit wide time-slots

0010 = Minimum Delay Connection Command (incl. Broadcast Connection)
(SPA, ITSA, DPA, OTSA are considered)

0011 = Send Message Command (always Constant Delay)
(DPA, OTSA, MV are considered)

0100 = Stop Message Command
(DPA, OTSA are considered)

0101 = Disconnect Command
(SPA, ITSA, DPA, OTSA, SCA are considered)

I1..0 see I1..0 of Constant Delay Connection Command (incl. Broadcast Connection)

0110 = Disconnect Part of Broadcast Command
(SPA, ITSA, DPA, OTSA, SCA are considered)

I1..0 see I1..0 of Constant Delay Connection Command (incl. Broadcast Connection)

0111 = Multipoint Connect Command
(SPA, ITSA, DPA, OTSA are considered)

I0 Multipoint MODE

0 = logical OR connection

1 = logical AND connection

PRELIMINARY**Register Description**

1000 = Disconnect All Command

1001 = Bidirectional Connect Command
(SPA, ITSA, DPA, OTSA are considered)

I0 Delay MODE

0 = Minimum Delay

1 = Constant Delay

1010 = Memory Dump (Connection and Data Memory)

I0 Memory Dump

0 = disable

1 = enable

PRELIMINARY

Register Description

Configuration Command Register 1 RD/WR

Address: 08H

Reset value: 00H

	7	6	5	4	3	2	1	0
CMD1	I3	I2	I1	I0	CC3	CC2	CC1	CC0

CC3..0 Command Code

0000 = no operation

0001 = not used

0010 = PLL Reference Selection Command
(GI1 is considered to set the frequency)

I3..0 Synchronization Information

0000 = no synchronization = internal oscillator (default)

0001 = synchronizes the PLL to PFS

0010 = synchronizes the PLL to PDC

0011 = not used

0100 = not used

0101 = synchronizes the PLL to NTKW_1

0110 = synchronizes the PLL to NTKW_2

0011 = Start Special Configuration Command

I3..0 Only one code is allowed

1111 = start special configuration register programming

0100 = Write Special Configuration Command

I3..0 Only one code is allowed

1111 = write special configuration register (GI1 is considered)

0101 = not used

0110 = PCM Clock Input/Output Selection Command
(Default: PFS and PDC inactive)

I2..0 Frequency Information

000 = not used

001 = enable PFS and PDC = 2.048 MHz

010 = enable PFS and PDC = 4.096 MHz

011 = enable PFS and PDC = 8.192 MHz

- 100 = enable PFS and PDC = 16.384 MHz
- I3** Direction Information
 - 0 = PFS and PDC as Input
 - 1 = PFS and PDC as Output
- 0111 = not used
- 1000 = not used
- 1001 = not used
- 1010 = Phase Alignment
 - I2..0** must be set to 000
 - I3** PLL Phase Alignment (Please see description, [Chapter 3.4.3](#))
 - 0 = disable (default after reset)
 - 1 = enable

The PLL phase alignment must be disabled for reference frequencies < 2.048 MHz
- 1011 = Set Bit Rate Command Local Bus (PCM)
(Default for all lines = 2.048 Mbit/s)
 - I1..0** Base Bit Rate Information
 - 00 = 2.048 Mbit/s
 - 01 = 4.096 Mbit/s
 - 10 = 8.192 Mbit/s
 - 11 = 16.384 Mbit/s
 - I2** Destination Information
 - 0 = no effect
 - 1 = set rate of input lines (SPA is considered)
 - I3** Destination Information
 - 0 = no effect
 - 1 = set rate of output lines (DPA is considered)
- 1100 = not used
- 1101 = Read Time-Slot Command
 - I0** Destination Information
 - 0 = read input time-slots (SPA, ITSA are considered)
 - 1 = read output time-slots (DPA, OTSA are considered)
- 1110 = not used

1111 = Bit Shift Command (GI1 is considered to set shift value)
(Default: Bit Shift is inactive)

11..0 Direction Control

00 = Set shift value for input line (SPA is considered)

01 = Set shift value for all input lines

10 = Set shift value for all output lines

11 = Set shift value for all lines (input and output)

PRELIMINARY

Register Description

Configuration Command Register 2 RD/WR

Address: 0AH

Reset value: 00H

	7	6	5	4	3	2	1	0
CMD2	I3	I2	I1	I0	CC3	CC2	CC1	CC0

CC3..0 Command Code

0000 = no operation at all

0001 = External Frequency

(Must be programmed first)

I0 Set External Frequency

0 = 32.768 MHz

1 = 16.384 MHz

I1 Fallback to Oscillator

0 = disable (and turn off "enable" status temporarily if fallback has occurred)

1 = enable

If "Fallback to Oscillator" is enabled and a fallback has occurred, the corresponding failure is indicated in the IESTA1 and/or IESTA2 registers. For all clock failures, the PLL bit ("PLL Source Failure Indication", IESTA2 register) as well as the clock source related bit (in IESTA1 or IESTA2 register) will be set to "1". With the clock valid again the previously changed bits in IESTA1 and/or IESTA2 are set back to "0", the fallback must be disabled (CMD2=01_H/11_H) for a few cycles and enabled again thereafter.

I2 APLL's parameters

0 = default

1 = start APLL with improved parameters

The command CMD2=41_H or CMD2=51_H to start the APLL with improved parameters must only be issued only once after Power Up

PRELIMINARY

Register Description

- 0010 = Parallel Mode
 - Set the first 8 local bus input lines as 8 parallel input lines and set the first 8 local bus output lines as 8 parallel output lines.
 - I0** Set Parallel Mode
 - 0 = disable
 - 1 = enable

- 0011 = IREQ Pin Command
 - I1..0** Set IREQ Pin
 - (Default: IREQ is inactive)
 - 00 = IREQ is active low
 - 01 = IREQ is active high
 - 10 = IREQ as open-drain pin
 - I2** Set Interrupt Time-Out Counter
 - Set the inactive time between two consecutive interrupts
 - 0 = disable = 20 ns
 - 1 = enable = 300 ns

- 0100 = PCM Standby Command
 - I0** Set Local Bus (PCM) to High Impedance
 - 0 = outputs are tristated (default)
 - 1 = outputs are enabled
 - I1** not used must be set to '0'
 - I2** not used must be set to '0'
 - I3** Internal PCM Clock Synchronization
 - 0 = Must be set in PCM clock master mode
 - 1 = Must be set in PCM clock slave mode

- 0101 = Loop Command
 - I0** Set PCM-PCM Loop
 - 0 = disable (default)
 - 1 = enable

- 0110 = GPCLK as Frame Signal Command (GI1, GI2 are considered)
 - (Default: All GPCLK's are tristated)
 - I2..0** GPCLK Line (7..0)

- I3** Invert Mode
 - 0 = frame signal is high active
 - 1 = frame signal is low active
- 0111 = GPCLK as Clock Signal Command (GI1 is considered to set the frequency)
(Default: All GPCLK's are tristated)
 - I2..0** GPCLK Line (7..0)
- 1000 = Set Range of Data Rate Command
To avoid loss of data this command should be issued only once after reset. If the range of data rate is changed later on, loss of data must be expected for up to four frames.
 - I3..0** Range Select
To specify the range the min and max codes have to be logical OR combined.
 - 0001 = 2.048 Mbit/s (default)
 - 0010 = 4.096 Mbit/s
 - 0100 = 8.192 Mbit/s
 - 1000 = 16.384 Mbit/s
- 1001 = Read Configuration
 - I3..0** Select Configuration Command
 - 0000 = not used
 - 0001 = PLL Source
 - 0010 = not used
 - 0011 = not used
 - 0100 = not use
 - 0101 = Local Bus (PCM) Clock Output Selection
 - 0110 = not used
 - 0111 = not used
 - 1000 = not used
 - 1001 = Phase Alignment
 - 1010 = External Input Frequency
 - 1011 = Parallel Mode
 - 1100 = IREQ Pin
 - 1101 = Local Bus Standby

PRELIMINARY**Register Description**

- 1110 = Loop
- 1111 = Range of Data Rate
- 1010 = Read GPCLK Configuration
 - I2..0** GPCLK Line 7..0
- 1011 = Read Local Bus (PCM) Line Configuration
 - I0** Destination Information
 - 0 = Read Data Rate of Input Line (SPA is considered)
 - 1 = Read Data Rate of Output Line (DPA is considered)
- 1100 = not used
- 1101 = Read Bit Shift Configuration
 - I0** Destination Information
 - 0 = Shift Value for Input Line (SPA is considered)
 - 1 = Shift Value for all Output Lines
- 1110 = not used
- 1111 = Software Reset
 - I0** Set Software Reset
 - 0 = Deactivate Software Reset (default)
 - 1 = Activate Software Reset

PRELIMINARY

Register Description

Message Value Register

RD/WR

Address: 0CH

Reset value: 00H

	7	6	5	4	3	2	1	0
MV	MV7	MV6	MV5	MV4	MV3	MV2	MV1	MV0

MV7..0 Message Value

PRELIMINARY

Register Description

Interrupt Status Register 1

RD

Address: 0EH

Reset value: 00H

	7	6	5	4	3	2	1	0
ISTA1	APLL	0	ER2	ER1	GPIO	TSA	NFC	RDY

APLL APLL lock indication

0 = PLL is not locked = bypassed

1 = PLL is locked

ER2 Error2 Interrupt Change Indication (not active in 16-bit mode)

0 = no change detected in the Interrupt Error Status Register 2 (IESTA2)

1 = change detected in the Interrupt Error Status Register 2 (IESTA2)

ER1 Error1 Interrupt Change Indication

0 = no change detected in the Interrupt Error Status Register 1 (IESTA1)

1 = change detected in the Interrupt Error Status Register 1 (IESTA1)

GPIO General Purpose Change Indication

0 = no change according to GP port inputs detected

1 = at least one change according to GP port inputs detected

TSA Time-Slot Arrived Indication

0 = there is no new time-slot value in the register TSV

1 = there is a new time-slot value in the register TSV

NFC No Further Connections Indication

0 = establishing of connections is possible

1 = the maximum amount of connections is reached

RDY Ready Indication

0 = CCMD is not ready to be written to

1 = CCMD is ready to be written to

PRELIMINARY

Register Description

Interrupt Error Status Register 1

RD

Address: 10H

Reset value: 00H

	7	6	5	4	3	2	1	0
IESTA1	0	0	0	0	0	0	NW2	NW1

NW2 NTWK_2 Failure Indication

NW1 NTWK_1 Failure Indication

for all these status bits the values can be

0 = no failure detected

1 = failure detected

Interrupt Error Status Register 2

RD

Address: 11H

Reset value: 00H

	7	6	5	4	3	2	1	0
IESTA2	CON	PLL	0	0	0	0	0	0

CON Connection Memory Error/Overflow Indication

PLL PLL Source Failure Indication

for all these status bits the values can be

0 = no failure detected

1 = failure detected

PRELIMINARY

Register Description

Interrupt Mask Register 1

RD/WR

Address: 12H

Reset value: 3DH

	7	6	5	4	3	2	1	0
INTM1	0	0	ER2	ER1	GPIO	TSA	0	RDY

ER2 Error2 Interrupt Change Indication Mask (not active in 16-bit mode)

0 = Do not mask the Change Indication Bit

1 = Mask the Change Indication Bit

ER1 Error1 Interrupt Change Indication Mask

0 = Do not mask the Change Indication Bit

1 = Mask the Change Indication Bit

GPIO General Purpose Change Indication Mask

0 = Do not mask the Change Indication Bit

1 = Mask the Change Indication Bit

TSA Time-Slot Arrived Indication Mask

0 = Do not mask the Time-Slot Arrived Indication Bit

1 = Mask the Time-Slot Arrived Indication Bit

RDY Ready Indication Mask

0 = Do not mask the Ready Indication Bit

1 = Mask the Ready Indication Bit

Mask = Disable the interrupt

PRELIMINARY

Register Description

Interrupt Error Mask Register 1

RD/WR

Address: 14H

Reset value: 3FH

	7	6	5	4	3	2	1	0
INTEM1	0	0	0	0	0	0	NW2	NW1

NW2 NTWK_2 Failure Indication Mask

NW1 NTWK_1 Failure Indication Mask

for all these indication bits the values can be

0 = Do not mask this interrupt

1 = Mask this interrupt

Mask = Disable the interrupt

Interrupt Error Mask Register 2

RD/WR

Address: 15H

Reset value: FFH

	7	6	5	4	3	2	1	0
INTEM2	CON	PLL	0	0	0	0	0	0

CON Connection Memory Overflow Indication Mask

PLL PLL Source Failure Indication Mask

for all these indication bits the values can be

0 = Do not mask this interrupt

1 = Mask this interrupt

Mask = Disable the interrupt

PRELIMINARY

Register Description

General Purpose Port Input Register RD

Address: 16H

Reset value: 00H

	7	6	5	4	3	2	1	0
GPPI	GPB7	GPB6	GPB5	GPB4	GPB3	GPB2	GPB1	GPB0

GPB7..0 General Purpose Bits

General Purpose Port Output Register WR

Address: 18H

Reset value: 00H

	7	6	5	4	3	2	1	0
GPPO	GPB7	GPB6	GPB5	GPB4	GPB3	GPB2	GPB1	GPB0

GPB7..0 General Purpose Bits

General Purpose Direction Register RD/WR

Address: 1AH

Reset value: 00H

	7	6	5	4	3	2	1	0
GPD	DC7	DC6	DC5	DC4	DC3	DC2	DC1	DC0

DC7..0 Direction Control

0 = set line as input

1 = set line as output

PRELIMINARY

Register Description

General Purpose Mask Register

RD/WR

Address: 1BH

Reset value: FFH

	7	6	5	4	3	2	1	0
GPM	IM7	IM6	IM5	IM4	IM3	IM2	IM1	IM0

IM7..0 GPIO Interrupt Mask (bit 0 for line 0, bit 1 for line 1 ..)

0 = enable change detection

1 = disable change detection

General Purpose Interrupt Register

RD

Address: 1CH

Reset value: IDCODE (hardware reset) 00_H (software reset)

	7	6	5	4	3	2	1	0
GPI	IND7	IND6	IND5	IND4	IND3	IND2	IND1	IND0

IND7..0 GPIO Interrupt Indication (bit 0 for line 0, bit 1 for line 1 ..)

0 = no change detected

1 = at least one change detected on this line

PRELIMINARY

Register Description

Time-Slot Value Register

RD

Address: 1EH

Reset value: XXH

	7	6	5	4	3	2	1	0
TSV	TSV7	TSV6	TSV5	TSV4	TSV3	TSV2	TSV1	TSV0

For the Read Time-Slot Value Command the content of the TSV register is interpreted as:

TSV7..0 Time-Slot Value

For the Read Configuration Command the content of the TSV register is interpreted as:

PLL Reference Configuration

TSV3..0 See I3..0 from PLL Reference Selection Command (page [49](#))

- TSV6..4**
- 000 = 8 kHz
 - 001 = 512 kHz
 - 010 = 1.536 MHz
 - 011 = 1.544 MHz
 - 100 = 2.048 MHz
 - 101 = 4.096 MHz
 - 110 = 8.192 MHz
 - 111 = 16.384 MHz

PCM Clock Output Selection

TSV3..0 See I3..0 from PCM Clock Output Selection Command (page [49](#))

- 00 = 8 kHz
- 01 = 512 kHz
- 10 = 2.048 MHz

Phase Alignment

TSV3 See I3 Phase Alignment Command (page [50](#))

External Frequency

TSV0 See I0 from Set External Frequency Command (page [52](#))

Parallel Mode

TSV0 See I0 from Set Parallel Mode Command (page 53)

IREQ Pin

TSV2..0 See I1..0 from Set IREQ Pin Command (page 53)

Local Bus (PCM) Standby

TSV1..0 See I0 from Set Local Bus (PCM) Standby Command (page 53)

Loop

TSV1..0 See I1..0 from Loop Command (page 53)

Range of Data Rate

TSV3..0 See I3..0 from Set Range of Data Rate Command (page 54)

For the Read GPCLK Configuration Command the content of the TSV register is interpreted as:

TSV0 0 = GPCLK Line as Clock Signal
 1 = GPCLK Line as Frame Signal

GPCLK Line as Clock Signal

TSV3..1 000 = 8 kHz
 001 = 2.048 MHz
 010 = 4.096 MHz
 011 = 8.192 MHz
 100 = 16.384 MHz
 101 = Input Analog PLL
 110 = Internal Frequency

GPCLK Line as Frame Signal

TSV1 0 = Rising Edge
 1 = Falling Edge

TSV7..2 Offset within the PFS frame in number of 16.384 MHz clock cycles (lower 6 bits; refer to CON for the upper part)

PRELIMINARY**Register Description**

For the Read Local Bus (PCM) Line Configuration Command the content of the TSV register is interpreted as:

TSV1..0	00 =	2.048 MBit/s
	01 =	4.096 MBit/s
	10 =	8.192 MBit/s
	11 =	16.384 MBit/s

In case of the Read Bit Shift Configuration Command the content of the TSV register is interpreted as:

TSV0	Edge Control
	0 = Rising Edge
	1 = Falling Edge
TSV3..1	Bit Shift Value (Range: 7 to 0)
TSV4	Byte Shift Value (only for input lines)
	0 = bit shift applies to byte before PFS rising edge
	1 = bit shift applies to byte before PFS falling edge

PRELIMINARY

Register Description

Configuration Register

RD

Address: 1FH

Reset value: XXH

	7	6	5	4	3	2	1	0
CON	CON7	CON6	CON5	CON4	CON3	CON2	CON1	CON0

For the Memory Dump Command (CCMD) the content of the CON register is:

CON7..0 Connection and Data Memory

For the Read GPCLK Configuration Command the content of the CON register is:

CON7..5 Width of the pulse in number of 16.384 MHz clock cycles from 1 to 8
i.e. CON7..5 = 000 => 1 clock cycle, CON7..5 = 010 => 3 clock cycles

CON4..0 Offset within the PFS frame in number of 16.384 MHz clock cycles (upper 5 bits; refer to TSV for the lower part)

5.3 Register Overview For 16-Bit Interface

Table 16 Register Overview For 16-Bit Interface

Reg Name	Access	Address	Reset Value	Comment	Page No.
SA	RD/WR	00 _H	0000 _H	Source Address Register	68
DA	RD/WR	02 _H	0000 _H	Destination Address Register	68
GI	RD/WR	04 _H	0000 _H	General Input Register	69
CC16	RD/WR	06 _H	0000 _H	Connection Command Register 16-bit	69
CMD1	RD/WR	08 _H	00 _H	Configuration Command Register 1 This is a 8-bit register	49
CMD2	RD/WR	0A _H	00 _H	Configuration Command Register 2 This is a 8-bit register	52
MV	RD/WR	0C _H	00 _H	Message Value Register This is a 8-bit register	56
ISTA1	RD	0E _H	00 _H	Interrupt Status Register 1 This is a 8-bit register	57
IESTA	RD	10 _H	0000 _H	Interrupt Error Status Register	70
INTM1	RD/WR	12 _H	3D _H	Interrupt Mask Register This is a 8-bit register	59
INTEM	RD/WR	14 _H	FF3F _H	Interrupt Error Mask Register	70
IDC	RD	1C _H	IDCODE	IDCODE Register This is a 8-bit register	71
T SVC	RD	1E _H	XXXX _H	Time-Slot Value / Configuration Register	71

5.4 Detailed Register Description For 16-Bit Interface

Source Address Register RD/WR Address: 00H

Reset value: 0000H

	15	14	13	12	11	10	9	8
	TSA7	TSA6	TSA5	TSA4	TSA3	TSA2	TSA1	TSA0
SA								
	7	6	5	4	3	2	1	0
	0	0	0	0	PA3	PA2	PA1	PA0

High See Input Time-Slot Address Register on page [42](#)

Low See Source Port Address Register on page [42](#)

Destination Address Register RD/WR Address: 02H

Reset value: 0000H

	15	14	13	12	11	10	9	8
	TSA7	TSA6	TSA5	TSA4	TSA3	TSA2	TSA1	TSA0
DA								
	7	6	5	4	3	2	1	0
	0	0	0	0	PA3	PA2	PA1	PA0

High See Output Time-Slot Address Register on page [43](#)

Low See Destination Port Address Register on page [42](#)

PRELIMINARY

Register Description

General Input Register

RD/WR

Address: 04H

Reset value: 0000H

	15	14	13	12	11	10	9	8
	GV15	GV14	GV13	GV12	GV11	GV10	GV9	GV8
GI								
	7	6	5	4	3	2	1	0
	GV7	GV6	GV5	GV4	GV3	GV2	GV1	GV0

GV15..0 General Value

GV15..8 See General Input Register 2 on page [46](#)

GV7..0 See General Input Register 1 on page [44](#)

Connection Command Register 16-bit

RD/WR

Address: 06H

Reset value: 0000H

	15	14	13	12	11	10	9	8
	0	0	OSCA2	OSCA1	OSCA0	ISCA2	ISCA1	ISCA0
CC16								
	7	6	5	4	3	2	1	0
	I3	I2	I1	I0	CC3	CC2	CC1	CC0

High See Subchannel Address Register on page [43](#)

Low See Connection Command Register on page [47](#)

PRELIMINARY

Register Description

Interrupt Error Status Register

RD

Address: 10H

Reset value: 0000H

	15	14	13	12	11	10	9	8
	CON	PLL	0	0	0	0	0	0
IESTA								
	7	6	5	4	3	2	1	0
	0	0	0	0	0	0	NW2	NW1

High See Interrupt Error Status Register 2 on page [58](#)

Low See Interrupt Error Status Register 1 on page [58](#)

Interrupt Error Mask Register

RD/WR

Address: 14H

Reset value: FF3FH

	15	14	13	12	11	10	9	8
	CON	PLL	0	0	0	0	0	0
INTEM								
	7	6	5	4	3	2	1	0
	0	0	0	0	0	0	NW2	NW1

High See Interrupt Error Mask Register 2 on page [60](#)

Low See Interrupt Error Mask Register 1 on page [60](#)

PRELIMINARY

Register Description

IDCODE Register

RD

Address: 1CH

Reset value: IDCODE

	7	6	5	4	3	2	1	0
IDC	IDC7	IDC6	IDC5	IDC4	IDC3	IDC2	IDC1	IDC0

IDC7..0 IDCODE refer to [Table 11 "IDCODE via μP Read Access" on Page 38](#)

Time-Slot Value / Configuration Register RD

Address: 1EH

Reset value: XXXXH

	15	14	13	12	11	10	9	8
	TSVC15	TSVC14	TSVC13	TSVC12	TSVC11	TSVC10	TSVC9	TSVC8
TSVC	7	6	5	4	3	2	1	0
	TSVC7	TSVC6	TSVC5	TSVC4	TSVC3	TSVC2	TSVC1	TSVC0

TSVC15..8 Configuration and Connection Data Memory (refer to page [66](#))

TSVC7..0 Time-Slot Value (refer to page [63](#))

6 Programming the Device

The register set consists of parameter registers (**SPA, ITSA, SCA, DPA, OTSA, GI1..**), command registers (**CCMD, CMD1, CMD2**) and status registers (**ISTA1, IESTA1, IESTA2**). Please note that some bits contained in the register **ISTA1** (Interrupt Status Register 1) do not generate any interrupt, for more details see the paragraph **Chapter 6.2**.

Before issuing a command the parameter registers have to be written accordingly. A connection command can only be issued if the connection command register is ready to be written to (see **Figure 15**). The connection command register status is shown with the RDY bit in the **ISTA1** register. A detailed description for the read and write access to the command registers can be found in **Chapter 6.1**.

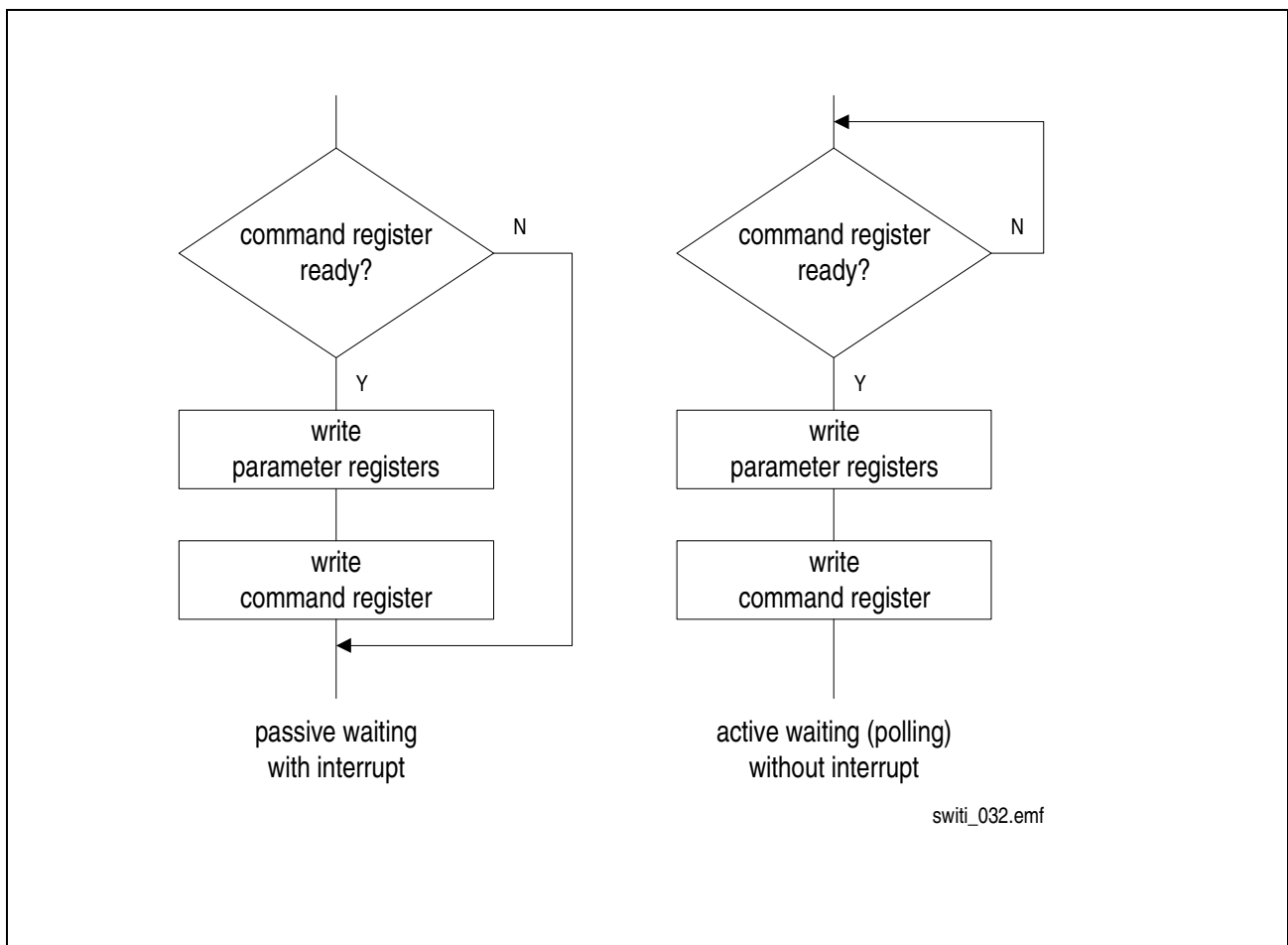

Figure 15 Order of Register Access

6.1 Read and Write Access

For the read and write access it is necessary to distinguish between a connection and configuration command. The connection command register is used to establish a connection (described in [Chapter 6.10](#)) and the configuration registers are used to configure the device, e.g. set the clock frequency.

If the **ISTA1:RDY** bit is set the connection command register is ready to receive data from the μ P interface. If the parameter register and the connection command register are written the RDY bit will be reset from the internal controller. If the connection is established the internal controller will set the RDY bit and the connection command register is ready for the next write or read access. The **ISTA1:RDY** can be enabled to generate an interrupt to indicate that the device is ready to receive the data, otherwise the μ P must poll the **ISTA1:RDY** bit.

The configuration command register works independent from the RDY bit.

Note: *There must be a recovery time period of 120 ns after every configuration command write access to the next write access (command or parameter register).*

6.2 Interrupt Handling

The SWITI interrupt concept consists of four interrupt status register with their corresponding mask register. The five interrupt status register can be divided in one main register, and a sub group including two error interrupt register, one general purpose interrupt register and one time-slot value register. Every sub register has a bit in the main register to indicate the set of an interrupt in the assigned error or general purpose register or to indicate a new value in the time-slot value register.

The interrupt status register can be read via the microprocessor interface. The NFC and RDY will be set and reset from the internal controller.

When an interrupt occurs one or more of the bit GPIO, TSA, ER2, or ER1 is set, then the assigned secondary interrupt status register or time-slot value register must be read first in order to check for the cause of the interrupt. After a secondary status register read access, the error status register and the corresponding bit in the Interrupt Status Register 1 (**ISTA1**) will be reset.

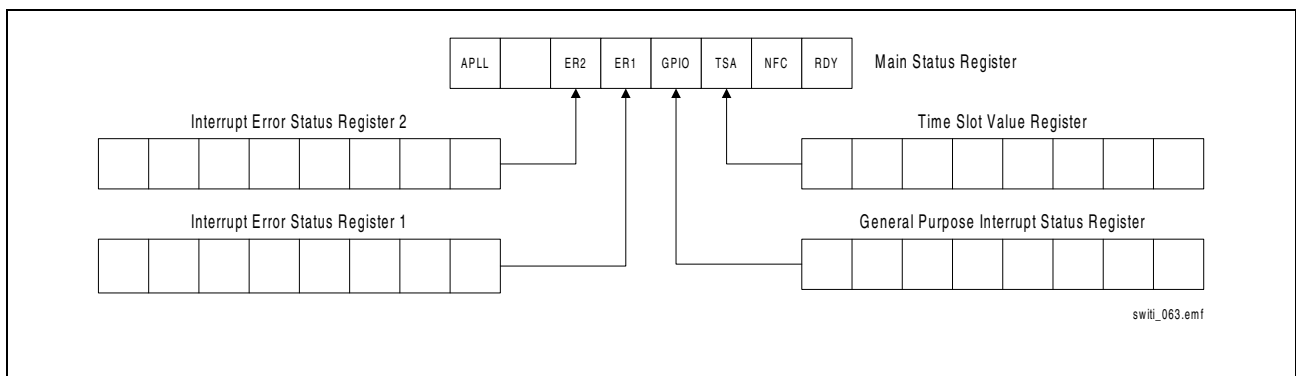

Figure 16 8-bit µP Access Interrupt Structure

The IREQ output is level active. It stays active until all interrupt sources have been serviced. If a new status bit is set while an interrupt is being serviced (µP read access), the IREQ pin stays active. For the duration of a write access to the **INTM1** register the IREQ line is deactivated. When using an edge-triggered interrupt controller, it is recommended to rewrite the **INTM1** register at the end of any interrupt service routine.

APLL, STR, RDY and NFC Bits

If the internal controller does set the RDY bit for the first time and the bit is not masked an interrupt will be generated. If the µP reads the **ISTA1** register the interrupt will be deactivated. The RDY bit is still active and can be reset from the internal controller.

The NFC, STR and APLL bits are not set by any interrupt and therefore can not be masked. Setting these bit does not generate any interrupt. The NFC bit is set from the internal controller if no further connections can be established. The STR bit is set from the internal stream to stream controller if a stream to stream connection is configured. The APLL bit is set from the internal analog PLL controller if the PLL is locked.

Masking Interrupts

If an interrupt is not masked (enabled) the IREQ pin will be active if one of the status bits in the interrupt status register is set. The mask bit prevents that the IREQ pin will be active if the status bit is set. The mask bits for the error status registers or general purpose interrupt register disable the interrupt indication for the interrupt status register. Only the interrupt status register can set the IREQ pin if the bit is not masked.

Interrupt Structure for a 16-bit Microprocessor Access

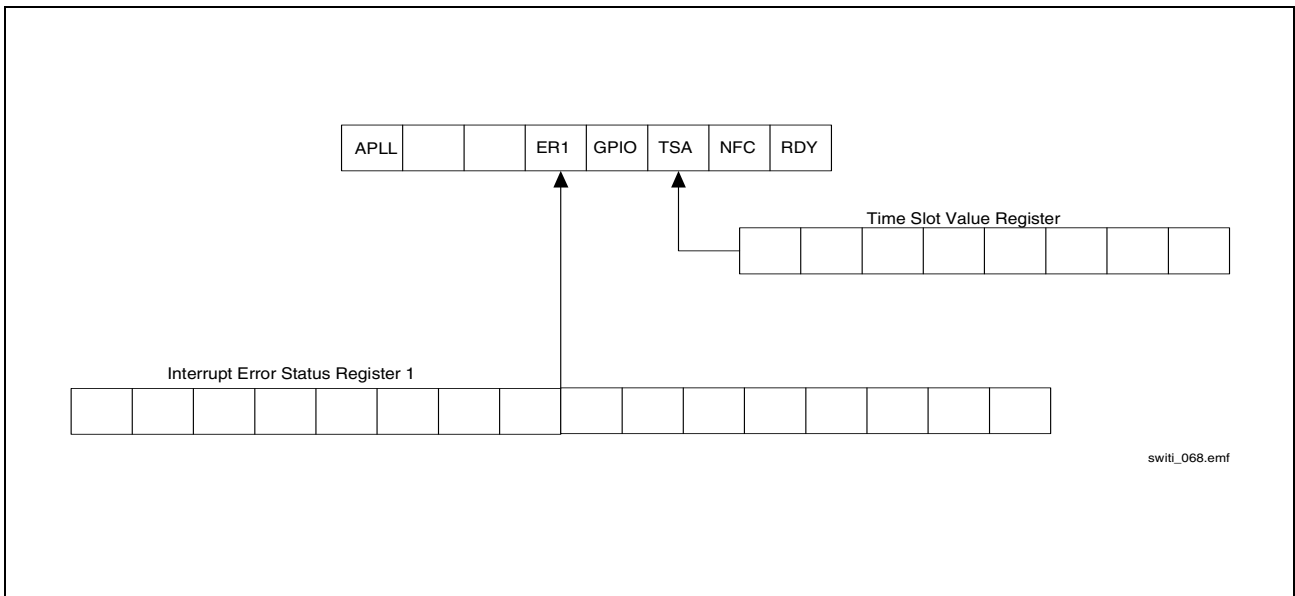

Figure 17 16-bit μ P Access Interrupt Structure

In opposite to the 8-bit μ P access there is only one bit (ER1) to indicate a change in the 16-bit Interrupt Error Status Register 1.

6.3 Command and Register Overview

The following table ([Table 17](#)) shows which parameter registers are considered by issuing an appropriate connection command.

Table 17 Affected Registers for Connection Commands

Command	Registers								
	SPA	ITSA	SCA	DPA	OTSA	MV	GI1	GI2	CON
Connect/Disconnect (without subchannels)	x	x		x	x				
Connect (with subchannels)	x	x	x	x	x				
Disconnect (with subchannels)	x	x		x	x				
Send Message				x	x	x			
Stop Message				x	x				
Disconnect Part of Broadcast (without subchannels)	x	x		x	x				
Disconnect Part of Broadcast (with subchannels)	x	x	x	x	x				
Multipoint Connect/Disconnect	x	x		x	x				
Bidirectional Connection	x	x		x	x				
Disconnect All									
Memory Dump (Connection and Data Memory)									x

PRELIMINARY

Programming the Device

The following table (**Table 18**) shows which parameter registers are considered by issuing an appropriate configuration command.

Table 18 Affected Registers for Configuration Commands

Command	Registers									
	CMD1	CMD2	SPA	ITSA	SCA	DPA	OTSA	GI1	GI2	TSV
PLL Reference	x							x		
PCM Clock Output	x									
Phase Alignment	x									
Set Bit Rate Local Bus	x		x			x				
Read Time-Slot	x		x	x		x	x			
Clock Shift	x		x					x		
External Input Frequency		x								
Set Parallel Mode		x								
Set IREQ Pin		x								
Standby Local Bus		x								
Set Loop		x								
Frame Signal		x						x	x	
GPCLK Clock		x						x		
Set Range of Data Rate		x								
Read Configuration		x								x
Read GPCLK Configuration		x								x
Read Local Bus Configuration		x								x
Read Bit Shift Configuration		x								x
Software Reset		x								

PRELIMINARY

Programming the Device

The command registers have the following structure:

7	6	5	4	3	2	1	0
I3	I2	I1	I0	CC3	CC2	CC1	CC0

CC3..0 is the command code and I3..0 is the parameter code.

The following tables ([Table 19](#) to [Table 20](#)) show all valid values of command and parameter codes and the related function.

Table 19 Connection Command and Parameter Codes

Command ¹⁾	Command Code (low nibble)	Parameter Code (high nibble)	Note
Constant Delay Connect Disconnect	1 _H 5 _H	0 _H 1 _H 2 _H 3 _H	address 8-bit connections address 4-bit connections address 2-bit connections address 1-bit connections
Minimum Delay Connect	2 _H	x _H	
Send Message	3 _H	x _H	
Stop Message	4 _H	x _H	
Disconnect Part of Broadcast	6 _H	0 _H 1 _H 2 _H 3 _H	address 8-bit connections address 4-bit connections address 2-bit connections address 1-bit connections
Multipoint Connect	7 _H	0 _H 1 _H	OR connection of time-slots AND connection of time-slots
Disconnect All	8 _H	x _H	
Bidirectional Connect	9 _H	0 _H 1 _H	minimum delay constant delay
Memory Dump	A _H	0 _H 1 _H	disable enable

¹⁾ The input port is determined in SPA Bit3..0 and the output port in DPA Bit3..0. The input time-slot is determined in ITSA and the output time-slot in OTSA.

Table 20 Configuration Command 1 and Parameter Codes

Command	Command Code (low nibble)	Parameter Code (high nibble)	Note
Set Bit Rate Local Bus ¹⁾	B _H	0-3 _H	no effect
		4-7 _H	set bit rate of local input port (2/4/8/16 Mbit/s)
		8-B _H	set bit rate of local output port (2/4/8/16 Mbit/s)
		C-F _H	set for both input and output (2/4/8/16 Mbit/s)
Read Time-Slot ²⁾	D _H	0 _H	read time-slot of input port
		1 _H	read time-slot of output port
Bit Shift ³⁾	F _H	0 _H	set bit shift of input line
		1 _H	set bit shift of all input lines
		2 _H	set bit shift of all output lines
		3 _H	set bit shift of all input and output lines

¹⁾ the input and output port is determined in **SPA**, **DPA**

²⁾ the time-slot is determined in **SPA** and **ITSA** or **DPA** and **OTSA**

³⁾ the input line is determined in **SPA**, the shift information in **GI1**

Table 21 Configuration Command 2 and Parameter Code

Command	Command Code (low nibble)	Parameter Code (high nibble)	Note
External Frequency	1 _H	0 _H	set frequency to 32.768 MHz
		1 _H	set frequency to 16.384 MHz
Parallel Mode	2 _H	0 _H	disable
		1 _H	enable = first 8 local input bus lines are parallel and first 8 local output lines are parallel
Set IREQ Pin	3 _H	0 _H	IREQ is active low, timer = 20 ns
		1 _H	IREQ is active high, timer = 20 ns
		2 _H	IREQ as open-drain, timer = 20 ns
		4 _H	IREQ is active low, timer = 300 ns
		5 _H	IREQ is active high, timer = 300 ns
		6 _H	IREQ as open-drain, timer = 300 ns

PRELIMINARY

Programming the Device

Table 21 Configuration Command 2 and Parameter Code (cont'd)

Command	Command Code (low nibble)	Parameter Code (high nibble)	Note
Standby Local Bus	4 _H	0 _H 1 _H	disable Local Bus (PCM) enable Local Bus (PCM)
Loop	5 _H	0 _H 1 _H	no loop at all enable Local Bus Loop
Frame Signal ¹⁾	6 _H	0XXX _b 1XXX _b	signal is high active signal is low active XXX is the line address
GPCLK as Clock ²⁾	7 _H	0 _H -7 _H	parameter code is line address
Range of Data Rate	8 _H	0 _H -6 _H 8 _H -A _H	logical OR connection from min. and max. codes
Read Configuration ³⁾	9 _H	0 _H 1 _H 5 _H 9 _H A _H B _H C _H D _H E _H F _H	Master/Slave configuration PLL Reference Clock Output Selection Phase Alignment External Input Frequency Parallel Mode IREQ Pin Standby Local Bus Loop Range of Data Rate
Read GPCLK Configuration ⁴⁾	A _H	0 _H -7 _H	parameter code is line address
Read Local Bus Line Configuration ⁵⁾	B _H	0 _H 1 _H	Data Rate of Input Line ⁶⁾ Data Rate of Output Line ⁷⁾
Read Bit Shift Configuration ⁸⁾	D _H	0 _H 1 _H	Shift Value for Input Line ⁹⁾ Shift Value for all Output Lines

1) offset and width are determined in **GI1** and **GI2**

2) frequency is determined in **GI1**

3) The result can be read from the **TSV** register

4) The result can be read from the **TSV** and **CON** register

5) The result can be read from the **TSV** register

6) **SPA** must be used for line number

7) **DPA** must be used for line number

8) The result can be read from the **TSV** register

6.4 Indirect Configuration Register Access

It is possible to read the current SWITl configuration with an indirect register access for analyze and test purpose. There are five commands in the **CMD2** register which can be used to read the configuration. The clock generator output signal and external configuration for the SWITl can be read with the 'Read Configuration Command'. The four instruction bits select one possible configuration command. The current configuration is determined by the command written in the **TSV** register. The configuration information for every command can be found on page 40.

The line configuration can be read with the command 'Read Local Bus Line configuration'. Before the command will be issued the **SPA** or **DPA** register must be written with the port number. The configuration for the selected line is written in the **TSV** register by the internal controller. The interrupt handling is described in **Chapter 6.2**. The bit shift configuration can be read with the command 'Read Bit Shift Configuration' and the dataflow is the same as described above.

With the command 'Read GPCLK Configuration' it is possible to read the configuration for every GPCLK line. If this command is written the configuration can be read from the **TSV** and **CON** register. The **CON** register is not interrupt controlled and will keep the last data after a microprocessor read access.

To read the correct configuration data from the **TSV** register it is not allowed to use the command "Read Time-Slot Value" before the **TSV** register was read.

6.5 Initialization Procedure

After the reset process the PLL, local bus (PCM) interface, and some other signals need to be initialized.

Since the SWITI offers the possibility to use two different external crystal/oscillator frequencies the command 'Set external frequency' must be used first to set the correct frequency and to set the correct value of the input frequency for the APLL. After approximately 750µs the APLL is locked and the APLL status bit is set and the next commands can be written.

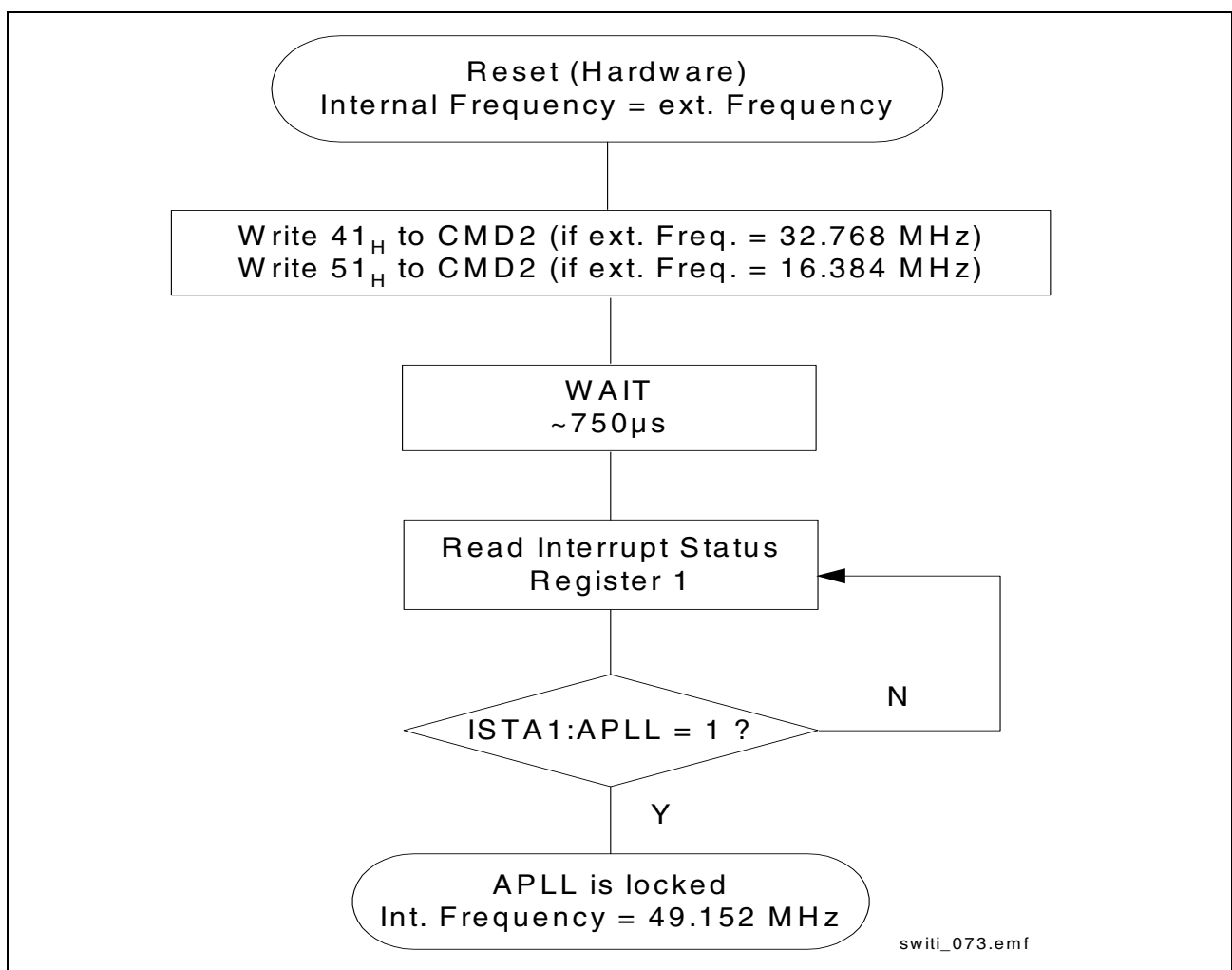

Figure 18 Initialization Procedure after Reset

After this initialization procedure the different functional blocks of the SWITI can be programmed.

- Local Bus (PCM) Interface
- Interrupt's and IREQ Pin
- GPCLK's and Frame Signals
- General Purpose Interface

6.6 Clocking Unit

The PCM clock signals for the line interface will be provided from external PCM devices if the SWITI is used as PCM clock slave or will be provided from the internal PLL if the SWITI is used as PCM clock master. This PCM clock configuration can be programmed with the special command 'PCM Input/Output Selection' in the **Figure CMD1** register.

For the PLL synchronization please refer to **Chapter 3.4.4** on page **27**.

Example:

SWITI as PCM clock master, PLL reference is NTKW_1 with 8 KHz and PDC is driven with 8.192 MHz and PFS is driven.

- Write 00_H to **GI1**
- Write 52_H to **CMD1**
- Write B6_H to **CMD1**

Example

SWITI as PCM clock slave, PLL reference is PDC with 4.096 MHz.

- Write 05_H to **GI1**
- Write 22_H to **CMD1**
- Write 26_H to **CMD1** (PDC = 4.096 MHz and PFS as input)

6.7 Local Bus (PCM) Line Interface

6.7.1 Standby Command

All PCM data lines are in a high impedance state after the reset process. If they are configured (data rate, bit shift) they can be enabled with the standby command. During the normal operation the PCM lines can be enabled or disabled with the standby command. If the lines are disabled the device works internally like an active device.

Example:

Set all output PCM lines to high impedance.

- Write 04_H to **CMD1**

6.7.2 Determining Clock Rates

The data rate range command is necessary to optimize the minimum delay feature. After the reset process the device assumes a bit rate of 2.048 Mbit/s for all PCM lines. The command must be issued if other data rates are used.

Example (8-bit μ P interface):

1. Specify that only 2.048 Mbit/s and 4.096 Mbit/s are used for following Set Bit Rate Command.
 - Write 38_H to **CMD2**
2. Set bit rate of 4.096 Mbit/s on local bus input line 8 and local bus output line 1
 - Write 08_H to **SPA**
 - Write 01_H to **DPA**
 - Write DB_H to **CMD1**

Example (16-bit μ P interface):

1.
 - Write 38_H to **CMD2**
2.
 - Write 0008_H to **SA**
 - Write 0001_H to **DA**
 - Write DB_H to **CMD1**

6.7.3 Performing Bit Shifting

The bit shift is performed on half-bit steps, not on a clock basis. It is a true bit shift, it means that with a data rate equals to the data clock frequency (e.g. 4.096 Mbit/s with 4.096 MHz data clock) programming a bit shift of 1-bit results on a shift of 1 clock period, and programming a shift of half-bit the result is a shift of half clock period. Running in double data clock rate (e.g. 4.096 Mbit/s with 8.192 MHz data clock), a bit shift of 1-bit results on a shift of 2 clock periods and a shift of half-bit will result on a shift of 1 clock period.

6.7.3.1 Input Bit Shifting

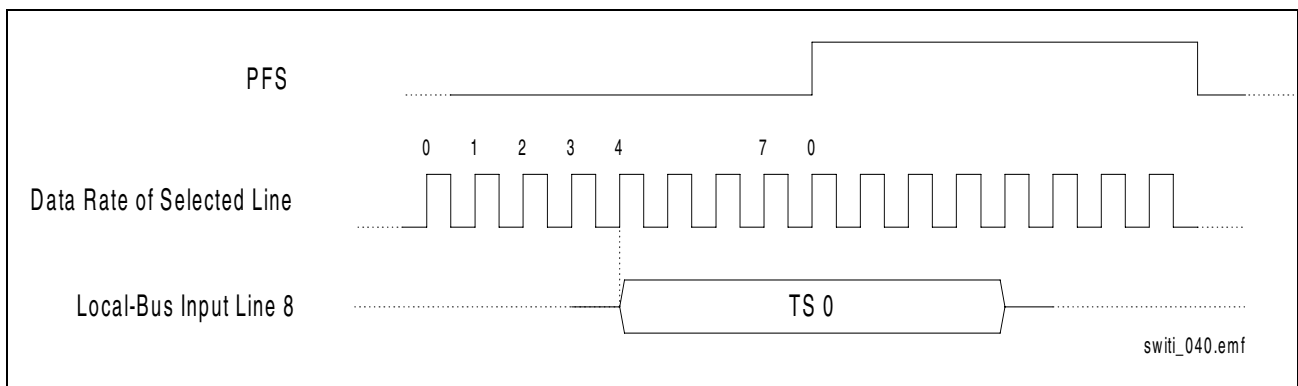

Figure 19 Example: Input Bit Shifting

Example (8-bit μ P interface):

Begin time-slot 0 of local input line 8 with the 4th rising edge relative to one byte before the PFS rising edge. The bits are internally sampled with the falling edge.

- Write 08_H to **SPA**
- Write 08_H to **GI1**
- Write 0F_H to **CMD1**

Example (16-bit μ P interface):

- Write 0008_H to **SA**
- Write 0008_H to **GI**
- Write 0F_H to **CMD1**

6.7.3.2 Output Bit Shifting

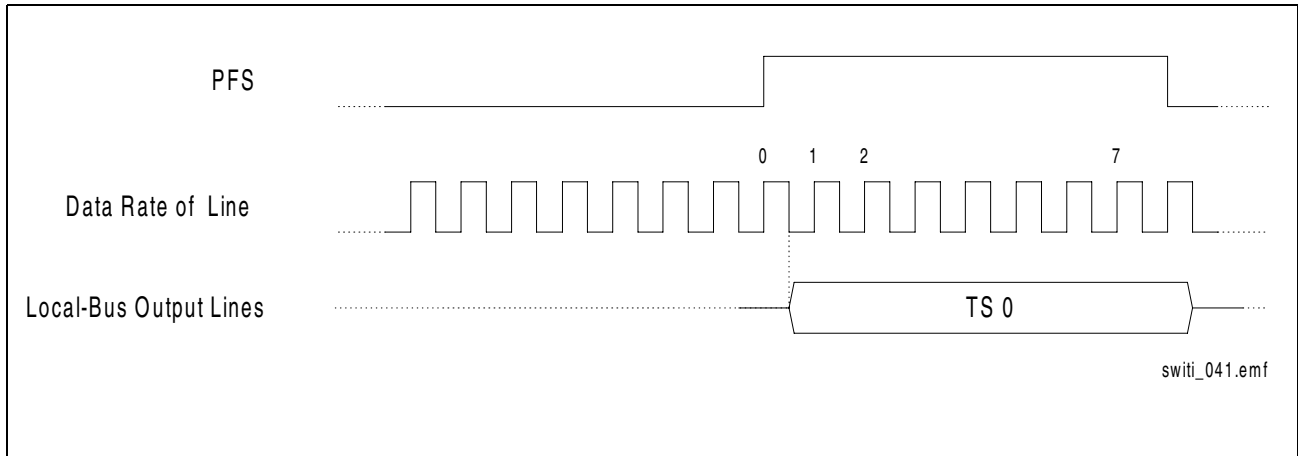

Figure 20 Example: Output Bit Shifting

Example (8-bit μ P interface):

Output time-slot 0 of all output lines begins with the first falling edge relative to the first byte after PFS rising edge. The bits are internally sampled with the rising edge.

- Write 01_H to **GI1**
- Write 2F_H to **CMD1**

Example (16-bit μ P interface):

- Write 0001_H to **GI**
- Write 2F_H to **CMD1**

6.8 Global Clock Signals

6.8.1 Framing Groups

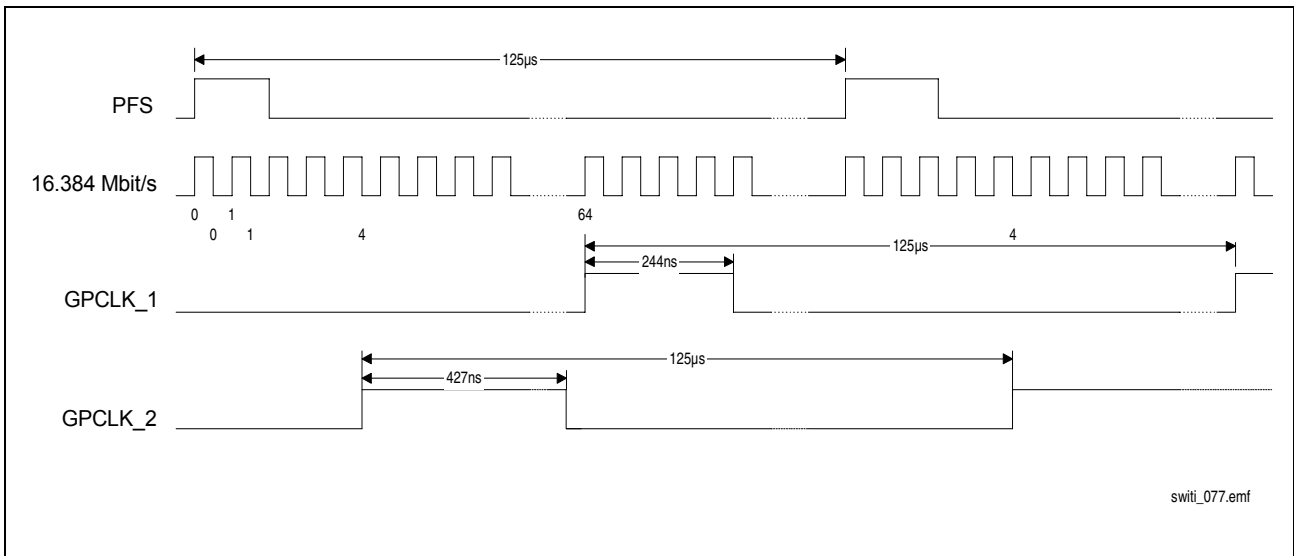

Figure 21 Example Framing Groups

Example (8-bit μ P interface):

Frame signal on GPCLK_1 starts with the rising edge of 64th clock cycle and the length is set to 244 ns (4 x 61 ns).

- Write 00_H to **GI1**
- Write 61_H to **GI2**
- Write 16_H to **CMD2**

Frame signal on GPCLK_2 starts with the falling edge of the 4th clock cycle and the length is set to 427 ns (7 x 61 ns).

- Write 12_H to **GI1**
- Write C0_H to **GI2**
- Write 26_H to **CMD2**

Example (16-bit μ P interface):

- Write 6100_H to **GI2**
- Write 0016_H to **CMD2**

- Write C012_H to **GI2**
- Write 0026_H to **CMD2**

6.9 Read Time-Slot Value

By issuing this command the time-slot value appears in the register **TSV** after arriving and an interrupt will be caused and a new read time-slot value will be accepted. The command has to be issued for every read request. The current TSV data will be overwritten if the read time-slot command is issued.

Example (8-bit μ P interface):

Read time-slot 10 of local bus input line 3

- Write 03_H to **SPA**
- Write $0A_H$ to **ITSA**
- Write $0D_H$ to **CMD1**

Example (16-bit μ P interface):

- Write $0A03_H$ to **SA**
- Write $0D_H$ to **CMD1**

Wrong Time-Slot and Time-Out

In some case it could be happen that the μ P tries to read a wrong time-slot. A wrong time-slot is defined as an invalid time-slot number for the selected data rate, e.g. data rate = 2 MBit/s and selected time-slot is 58. If the μ P tries to read a wrong time-slot no interrupt would be generated and the controller doesn't accept any further commands. The SWITI has an integrated time-out counter to allow a new read time-slot command after the maximum of three frames.

6.10 Establish Connections

The following chapter describes the programming of several kinds of connections. The programming interface allows to program or re-program a connection during the normal switching mode.

Before a new connection for a specific output time-slot and line will be programmed the specific connection has to be released.

6.10.1 Establish 8-bit Connections

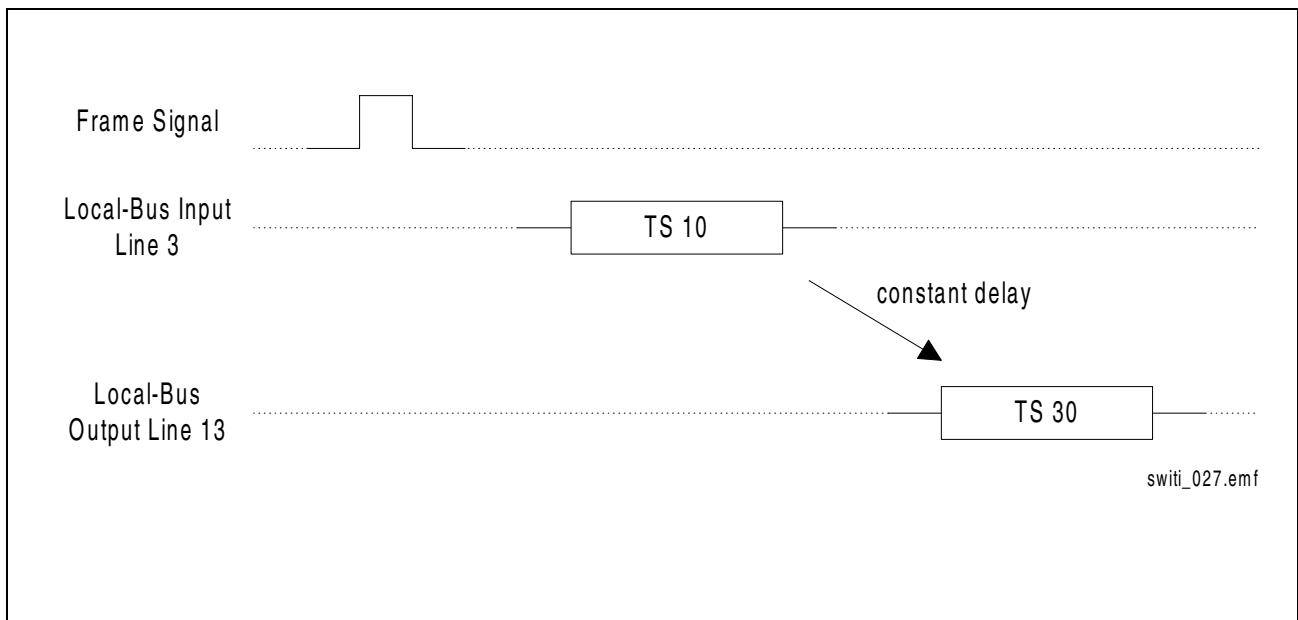

Figure 22 Example: 8-bit Connection

Example (8-bit μ P interface):

Connect time-slot 10 of local bus input line 3 with output time-slot 30 of local bus output line 13 as a constant delay connection

- Write 0A_H to **ITSA**
- Write 03_H to **SPA**
- Write 1E_H to **OTSA**
- Write 0D_H to **DPA**
- Write 01_H to **CCMD**

Example (16-bit μ P interface):

- Write 0A03_H to **SA**
- Write 1E0D_H to **DA**
- Write 0001_H to **CC16**

6.10.2 Subchannel Switching

With the subchannel address register (**SCA**) and the constant delay command it is possible to program 1,2, and 4 connections. The following figure explains the relation between the subchannel address and the corresponding bits in one time-slot.

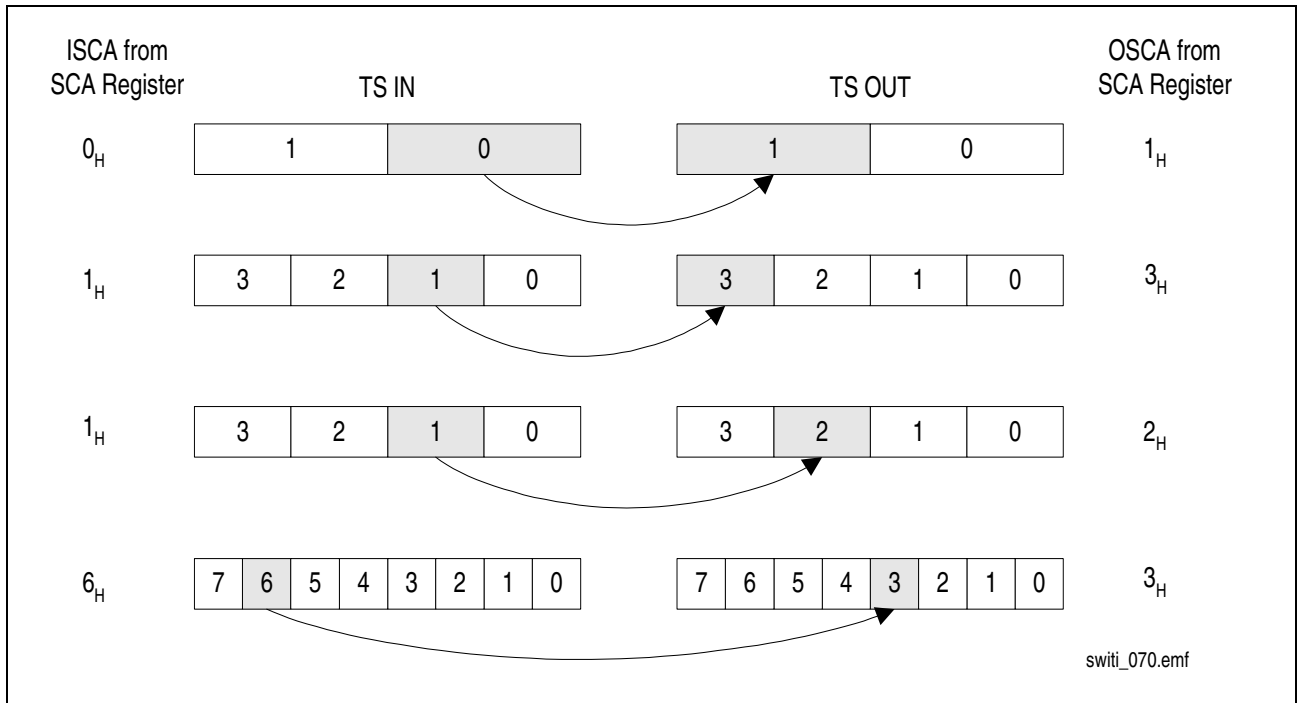

Figure 23 Subchannel Address in Time-Slot

6.10.2.1 Establish 4-bit Connections

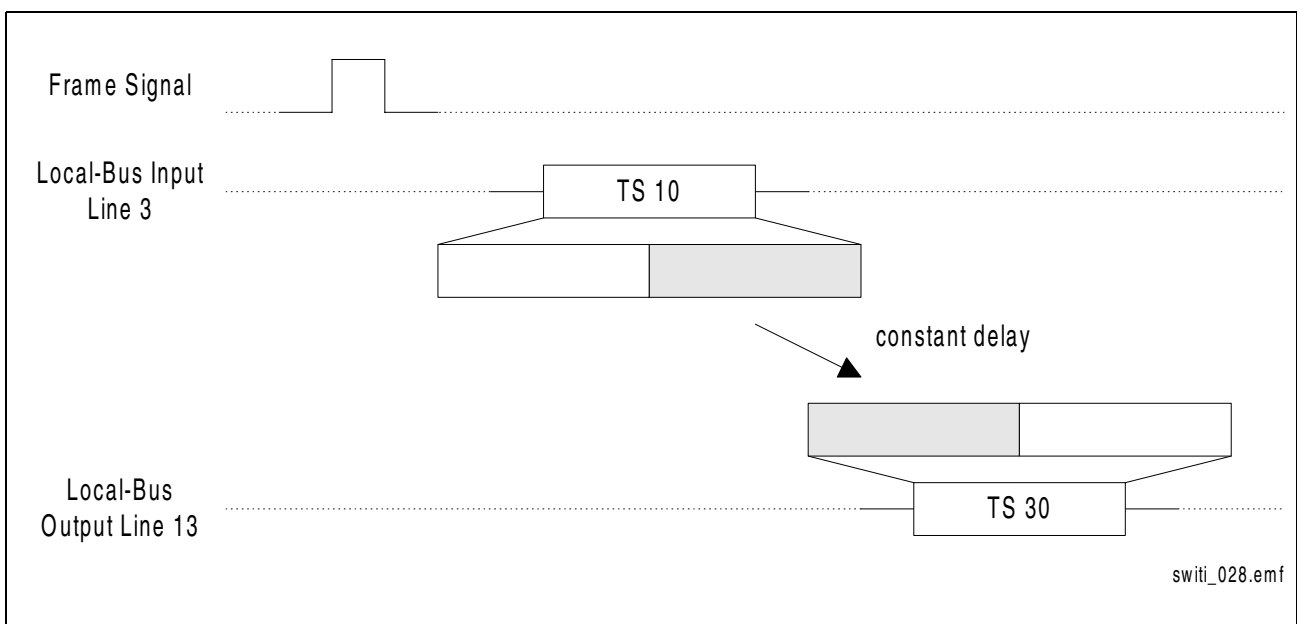

Figure 24 Example: 4-bit Connection

PRELIMINARY

Programming the Device

Example (8-bit μ P interface):

Connect low nibble of time-slot 10 of local bus input line 3 with high nibble of output time-slot 30 of local bus output line 13 as a constant delay connection

- Write 08_H to **SCA**
- Write 0A_H to **ITSA**
- Write 03_H to **SPA**
- Write 1E_H to **OTSA**
- Write 0D_H to **DPA**
- Write 11_H to **CCMD**

Example (16-bit μ P interface):

- Write 0A03_H to **SA**
- Write 1E0D_H to **DA**
- Write 0811_H to **CC16**

6.10.2.2 Establish 2-bit Connections

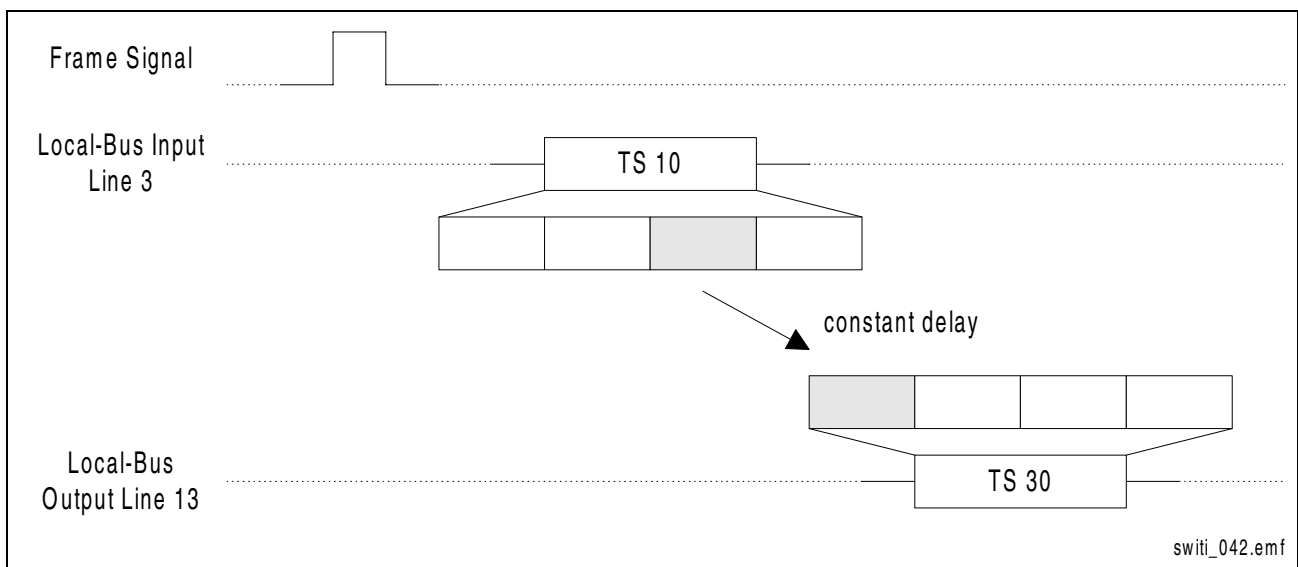

Figure 25 Example: 2-bit Connection

Example (8-bit μ P interface):

Connect 2nd 2-bit subchannel of time-slot 10 of local bus input line 3 with 4th 2-bit subchannel of output time-slot 30 of local bus output line 13 as a constant delay connection

- Write 19_H to **SCA**
- Write 0A_H to **ITSA**
- Write 03_H to **SPA**
- Write 1E_H to **OTSA**
- Write 0D_H to **DPA**
- Write 21_H to **CCMD**

Example (16-bit μ P interface):

- Write 0A03_H to **SA**
- Write 1E0D_H to **DA**
- Write 1921_H to **CC16**

6.10.2.3 Establish 1-bit Connections

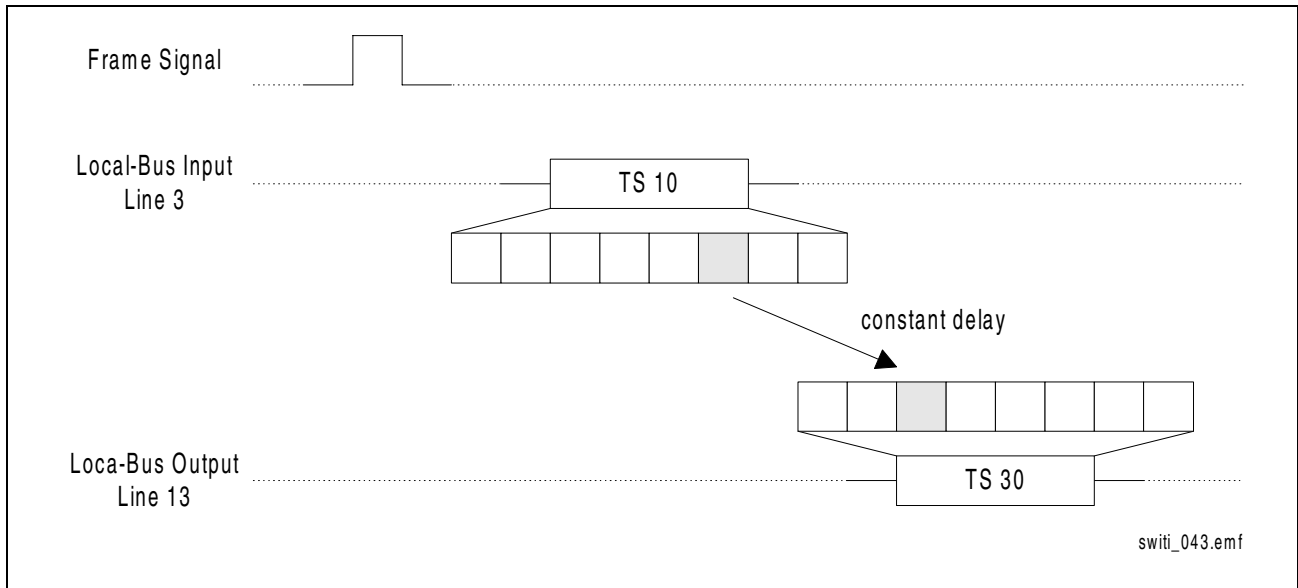

Figure 26 Example: 1-bit Connection

Example (8-bit μ P interface):

Connect 3rd 1-bit subchannel of time-slot 10 of local bus input line 3 with 6th 1-bit subchannel of output time-slot 30 of local bus output line 13 as a constant delay connection

- Write 2A_H to **SCA**
- Write 0A_H to **ITSA**
- Write 03_H to **SPA**
- Write 1E_H to **OTSA**
- Write 0D_H to **DPA**
- Write 31_H to **CCMD**

Example (16-bit μ P interface):

- Write 0A03_H to **SA**
- Write 1E0D_H to **DA**
- Write 2A31_H to **CC16**

6.10.3 Establish Broadcast Connections

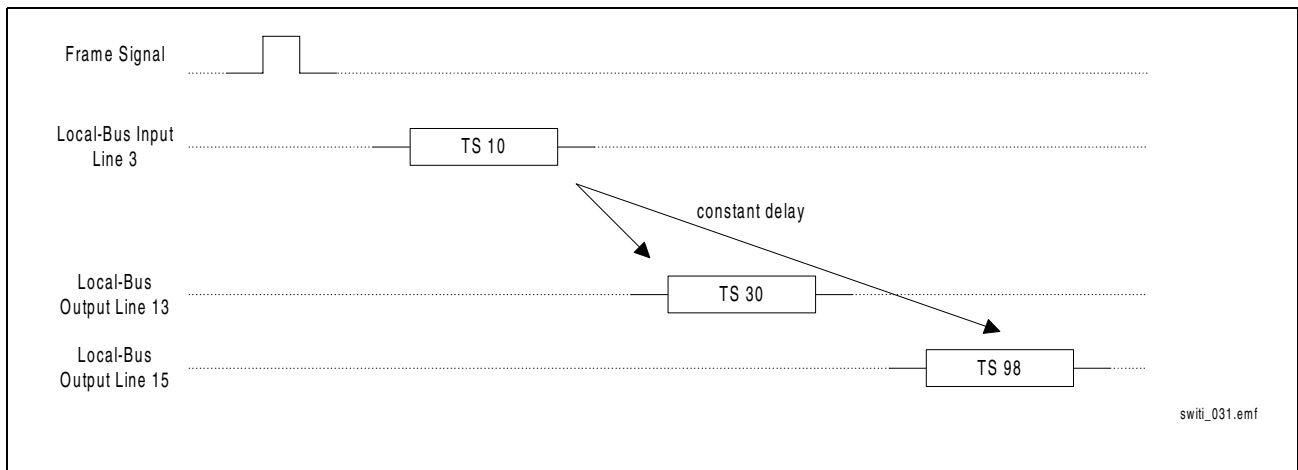

Figure 27 Example: Broadcast Connection

Example (8-bit μ P interface):

Connect time-slot 10 of local bus line 3 with output time-slot 30 of local bus output line 13 and output time-slot 98 of local bus output line 15 in constant delay mode. If the connections are established consecutively it is not necessary to rewrite the source determining registers **ITSA** and **SPA** because they keep their values.

- Write 0A_H to **ITSA**
- Write 03_H to **SPA**
- Write 1E_H to **OTSA**
- Write 0D_H to **DPA**
- Write 01_H to **CCMD**
- Write 62_H to **OTSA**
- Write 0F_H to **DPA**
- Write 01_H to **CCMD**

Example (16-bit μ P interface):

- Write 0A03_H to **SA**
- Write 1E0D_H to **DA**
- Write 0001_H to **CC16**
- Write 620F_H to **DA**
- Write 0001_H to **CC16**

6.10.4 Establish Subchannel Broadcast Connection

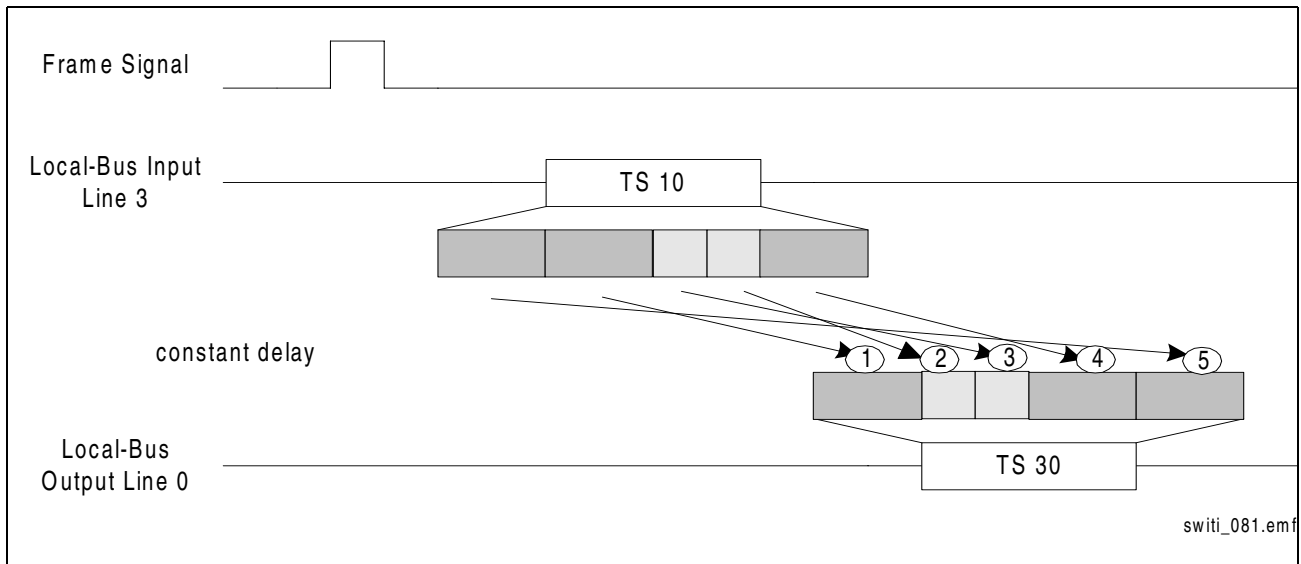

Figure 28 Example: Subchannel Broadcast Connection

- First Connection
 - Write 03_H to **SCA**
 - Write 0A_H to **ITSA**
 - Write 03_H to **SPA**
 - Write 1E_H to **OTSA**
 - Write 00_H to **DPA**
 - Write 21_H to **CCMD**
- Second Connection
 - Write 1A_H to **SCA**
 - Write 0A_H to **ITSA**
 - Write 03_H to **SPA**
 - Write 1E_H to **OTSA**
 - Write 00_H to **DPA**
 - Write 21_H to **CCMD**
- Third Connection
 - Write 23_H to **SCA**
 - Write 0A_H to **ITSA**
 - Write 03_H to **SPA**
 - Write 1E_H to **OTSA**
 - Write 00_H to **DPA**
 - Write 31_H to **CCMD**
- Fourth Connection
 - Write 2A_H to **SCA**
 - Write 0A_H to **ITSA**
 - Write 03_H to **SPA**

PRELIMINARY

Programming the Device

- Write 1E_H to **OTSA**
- Write 00_H to **DPA**
- Write 31_H to **CCMD**
- Fifth Connection
 - Write 08_H to **SCA**
 - Write 0A_H to **ITSA**
 - Write 03_H to **SPA**
 - Write 1E_H to **OTSA**
 - Write 00_H to **DPA**
 - Write 21_H to **CCMD**

6.10.5 Establish Multipoint Connection

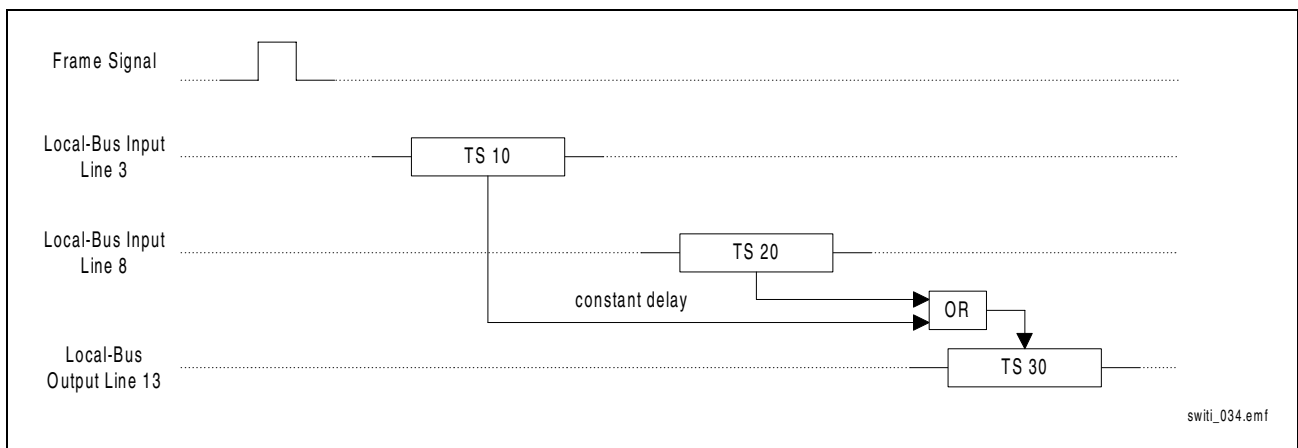

Figure 29 Example: Multipoint Connection

Example (8-bit μ P interface):

Connect time-slot 10 of local bus line 3 and time-slot 20 of local bus line 8 logical OR with output time-slot 30 of local bus output line 13 in constant delay mode. If the connections are established consecutively it is not necessary to rewrite the destination determining registers **OTSA** and **DPA** because they keep their values.

- Write 0A_H to **ITSA**
- Write 03_H to **SPA**
- Write 1E_H to **OTSA**
- Write 0D_H to **DPA**
- Write 07_H to **CCMD**
- Write 14_H to **ITSA**
- Write 08_H to **SPA**
- Write 07_H to **CCMD**

Example (16-bit μ P interface):

- Write 0A03_H to **SA**
- Write 1E0D_H to **DA**
- Write 0007_H to **CC16**
- Write 1408_H to **SA**
- Write 0007_H to **CC16**

6.11 Send Messages

Sending messages means to transmit a constant value on any time-slot or subchannel after the message is programmed within three frames. A message is sent continuously until the sending is stopped by the stop message command.

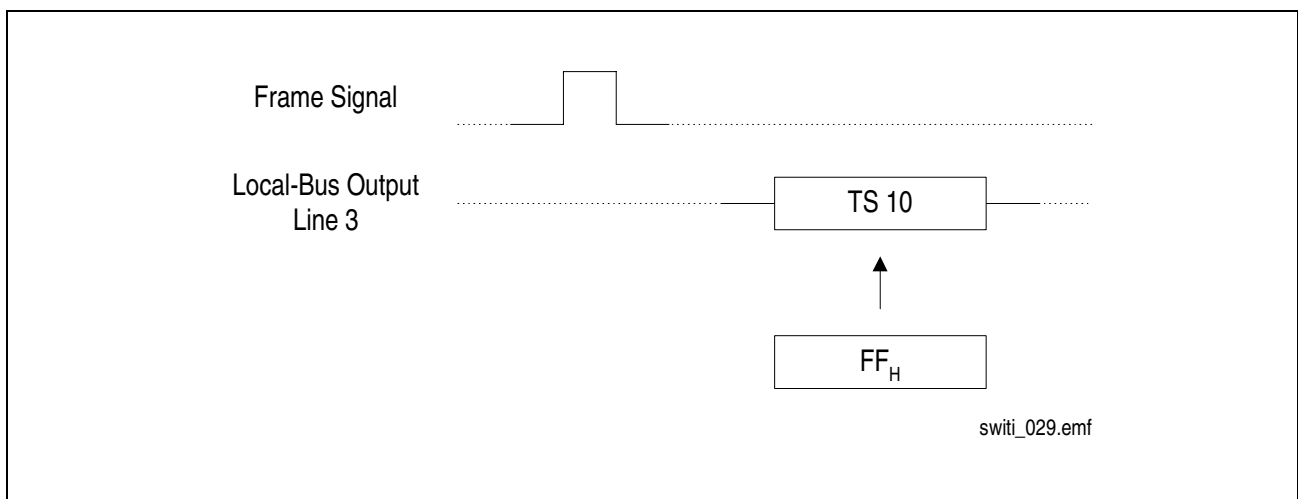

Figure 30 Example: Send Message

Example (8-bit μ P interface):

Send constant value of FF_H on time-slot 10 of local bus line 3

- Write FF_H to **MV**
- Write 0A_H to **OTSA**
- Write 03_H to **DPA**
- Write 03_H to **CCMD**

Example (16-bit μ P interface):

- Write FF_H to **MV**
- Write 0A03_H to **DA**
- Write 0003_H to **CC16**

6.12 Release Connections

6.12.1 Release 8-bit Connections

Example (8-bit μ P interface):

Release connection established in [Figure 22](#)

- Write $0A_H$ to **ITSA**
- Write 03_H to **SPA**
- Write $1E_H$ to **OTSA**
- Write $0D_H$ to **DPA**
- Write 05_H to **CCMD**

Example (16-bit μ P interface):

- Write $0A03_H$ to **SA**
- Write $1E0D_H$ to **DA**
- Write 0005_H to **CC16**

6.12.2 Release 4-bit Connections

Example (8-bit μ P interface):

Release connection established in [Figure 24](#)

- Write 08_H to **SCA**
- Write $0A_H$ to **ITSA**
- Write 03_H to **SPA**
- Write $1E_H$ to **OTSA**
- Write $0D_H$ to **DPA**
- Write 15_H to **CCMD**

Example (16-bit μ P interface):

- Write $0A03_H$ to **SA**
- Write $1E0D_H$ to **DA**
- Write 0815_H to **CC16**

6.12.3 Release 2-bit Connections

Example (8-bit μ P interface):

Release connection established in [Figure 25](#)

- Write 19_H to **SCA**
- Write $0A_H$ to **ITSA**
- Write 03_H to **SPA**

PRELIMINARY**Programming the Device**

- Write 1E_H to **OTSA**
- Write 0D_H to **DPA**
- Write 25_H to **CCMD**

Example (16-bit μ P interface):

- Write 0A03_H to **SA**
- Write 1E0D_H to **DA**
- Write 1925_H to **CC16**

6.12.4 Release 1-bit Connections

Example (8-bit μ P interface):

Release connection established in **Figure 26**

- Write 2A_H to **SCA**
- Write 0A_H to **ITSA**
- Write 03_H to **SPA**
- Write 1E_H to **OTSA**
- Write 0D_H to **DPA**
- Write 35_H to **CCMD**

Example (16-bit μ P interface):

- Write 0A03_H to **SA**
- Write 1E0D_H to **DA**
- Write 2A35_H to **CC16**

6.12.5 Release Broadcast Connection

Example (8-bit μ P interface):

Release connection established in [Figure 27](#). All but the last connection participating on a broadcast connection have to be released by the Disconnect Part of the Broadcast Command. The last connection has to be released by the **Constant Delay Connect Disconnect** Command.

- Write $0A_H$ to **ITSA**
- Write 03_H to **SPA**
- Write 62_H to **OTSA**
- Write $0F_H$ to **DPA**
- Write 06_H to **CCMD**
- Write $0A_H$ to **ITSA**
- Write 03_H to **SPA**
- Write $1E_H$ to **OTSA**
- Write $0D_H$ to **DPA**
- Write 05_H to **CCMD**

Example (16-bit μ P interface):

- Write $0A03_H$ to **SA**
- Write $620F_H$ to **DA**
- Write 0006_H to **CC16**
- Write $0A03_H$ to **SA**
- Write $1E0D_H$ to **DA**
- Write 0005_H to **CC16**

6.12.6 Release Subchannel Broadcast Connection

The order can be different as the establish order. The last release must be a normal release command.

- First Connection
 - Write 03_H to **SCA**
 - Write $0A_H$ to **ITSA**
 - Write 03_H to **SPA**
 - Write $1E_H$ to **OTSA**
 - Write 00_H to **DPA**
 - Write 26_H to **CCMD**
- Second Connection
 - Write $1A_H$ to **SCA**
 - Write $0A_H$ to **ITSA**
 - Write 03_H to **SPA**
 - Write $1E_H$ to **OTSA**

PRELIMINARY**Programming the Device**

- Write 00_H to **DPA**
- Write 26_H to **CCMD**
- Third Connection
 - Write 23_H to **SCA**
 - Write 0A_H to **ITSA**
 - Write 03_H to **SPA**
 - Write 1E_H to **OTSA**
 - Write 00_H to **DPA**
 - Write 36_H to **CCMD**
- Fourth Connection
 - Write 2A_H to **SCA**
 - Write 0A_H to **ITSA**
 - Write 03_H to **SPA**
 - Write 1E_H to **OTSA**
 - Write 00_H to **DPA**
 - Write 36_H to **CCMD**
- Fifth Connection
 - Write 08_H to **SCA**
 - Write 0A_H to **ITSA**
 - Write 03_H to **SPA**
 - Write 1E_H to **OTSA**
 - Write 00_H to **DPA**
 - Write 25_H to **CCMD**

6.12.7 Release Multipoint Connection

This type of connections is released with normal disconnect commands. (See “Release 8-bit Connections” on page 97.)

6.13 Stop Sending Messages

Example (8-bit μ P interface):

Stop sending message invoked in [Figure 30](#)

- Write 0A_H to **OTSA**
- Write 03_H to **DPA**
- Write 04_H to **CCMD**

Example (16-bit μ P interface):

- Write 0A03_H to **DA**
- Write 0004_H to **CC16**

7 Timing Diagrams

7.1 PCM Interface Timing

The following tables and figures give the PCM timing with a capacitive load of 50 pF. PDC and PFS are configured as inputs. The timing is also valid if PDC and PFS are configured as outputs. The PFS output high time is fixed to 488 ns for all data rates and clock rates. The PFS input minimum high time depends on the PDC input frequency (see [Table 22](#)).

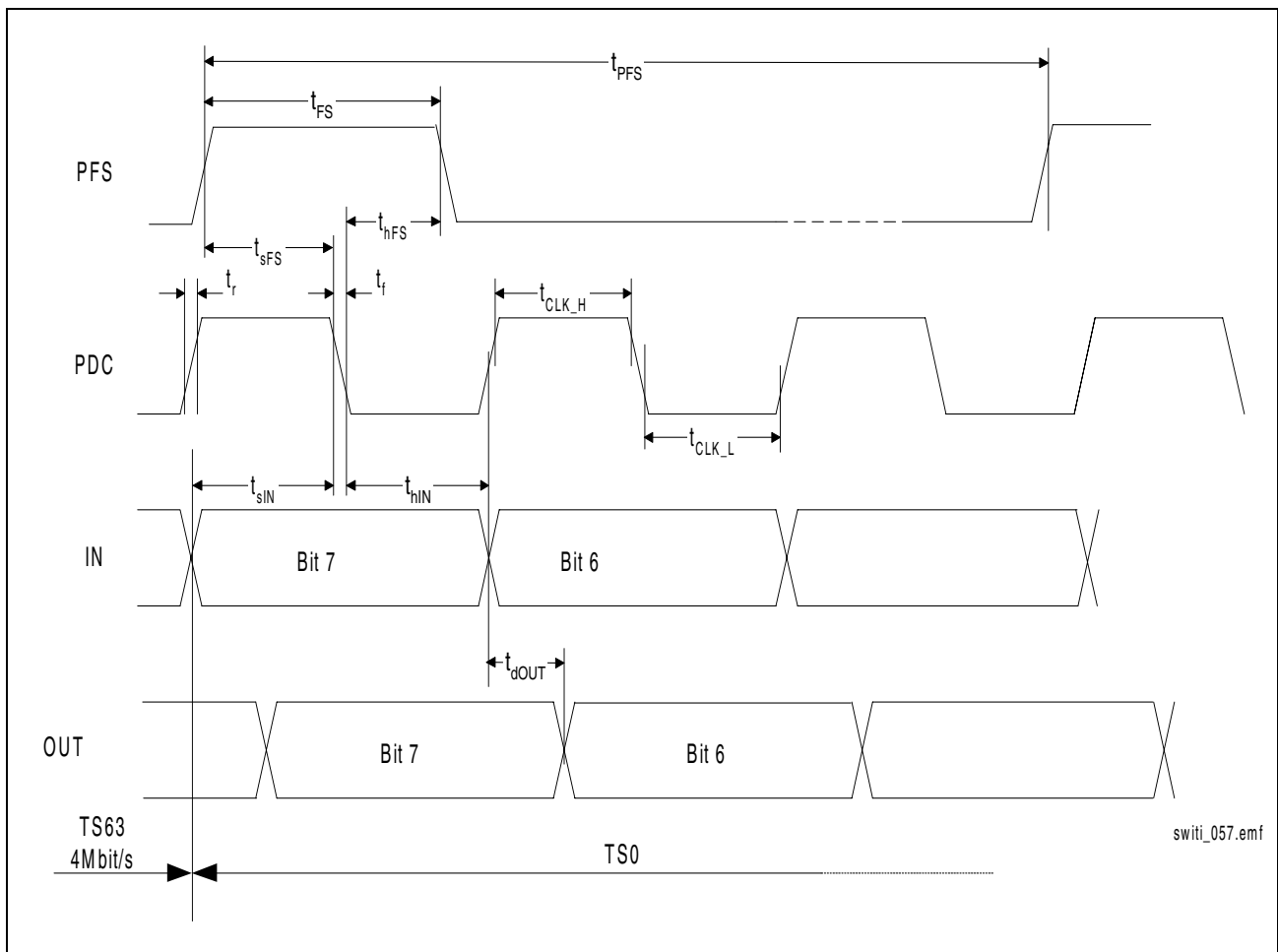

Figure 31 PCM Timing

PRELIMINARY
Timing Diagrams
Table 22 PCM Timing

Parameter	Symbol	Limit Values		Unit	Test Condition
		min.	max.		
Period PFS	t_{PFS}		125	μs	
PFS high time	t_{FS}	480		ns	PDC = 2.048 MHz
PFS set up time to clock	t_{sFS}	15		ns	
PFS hold time from clock	t_{hFS}	20		ns	
PFS high time	t_{FS}	240		ns	PDC = 4.096 MHz
PFS set up time to clock	t_{sFS}	15		ns	
PFS hold time from clock	t_{hFS}	20		ns	
PFS high time	t_{FS}	120		ns	PDC = 8.192 MHz
PFS set up time to clock	t_{sFS}	10		ns	
PFS hold time from clock	t_{hFS}	20		ns	
PFS high time	t_{FS}	60		ns	PDC = 16.384 MHz
PFS set up time to clock	t_{sFS}	10		ns	
PFS hold time from clock	t_{hFS}	20		ns	
PDC clock period	t_{CLK}	480		ns	PDC = 2.048 MHz
PDC clock period low	t_{CLK_L}	232	251	ns	
PDC clock period high	t_{CLK_H}	233	252	ns	
PDC clock period	t_{CLK}	240		ns	PDC = 4.096 MHz
PDC clock period low	t_{CLK_L}	112	131	ns	
PDC clock period high	t_{CLK_H}	113	132	ns	
PDC clock period	t_{CLK}	120		ns	PDC = 8.192 MHz
PDC clock period low	t_{CLK_L}	51	70	ns	
PDC clock period high	t_{CLK_H}	52	71	ns	
PDC clock period	t_{CLK}	60		ns	PDC = 16.384 MHz
PDC clock period low	t_{CLK_L}	26	34	ns	
PDC clock period high	t_{CLK_H}	27	35	ns	
PDC rise time	t_r		10	ns	
PDC fall time	t_f		10	ns	

PRELIMINARY
Timing Diagrams
Table 22 PCM Timing (cont'd)

Parameter	Symbol	Limit Values		Unit	Test Condition
		min.	max.		
Serial data input set up time	t_{sIN}	20		ns	PDC = 2.048 MHz
Serial data input hold time	t_{hIN}	30		ns	
Serial data input set up time	t_{sIN}	20		ns	PDC = 4.096 MHz
Serial data input hold time	t_{hIN}	30		ns	
Serial data input set up time	t_{sIN}	20		ns	PDC = 8.192 MHz
Serial data input hold time	t_{hIN}	30		ns	
Serial data input set up time	t_{sIN}	20		ns	PDC = 16.384 MHz
Serial data input hold time	t_{hIN}	30		ns	
Serial data output delay	t_{dOUT}	0	$30^{1)}$	ns	PDC = 2.048 MHz
Serial data output delay	t_{dOUT}	0	$30^{1)}$	ns	PDC = 4.096 MHz
Serial data output delay	t_{dOUT}	0	$30^{1)}$	ns	PDC = 8.192 MHz
Serial data output delay	t_{dOUT}	0	$30^{1)}$	ns	PDC = 16.384 MHz

¹⁾ for PCM Master, the maximum delay is 15 ns.

7.2 PCM Parallel Mode Timing

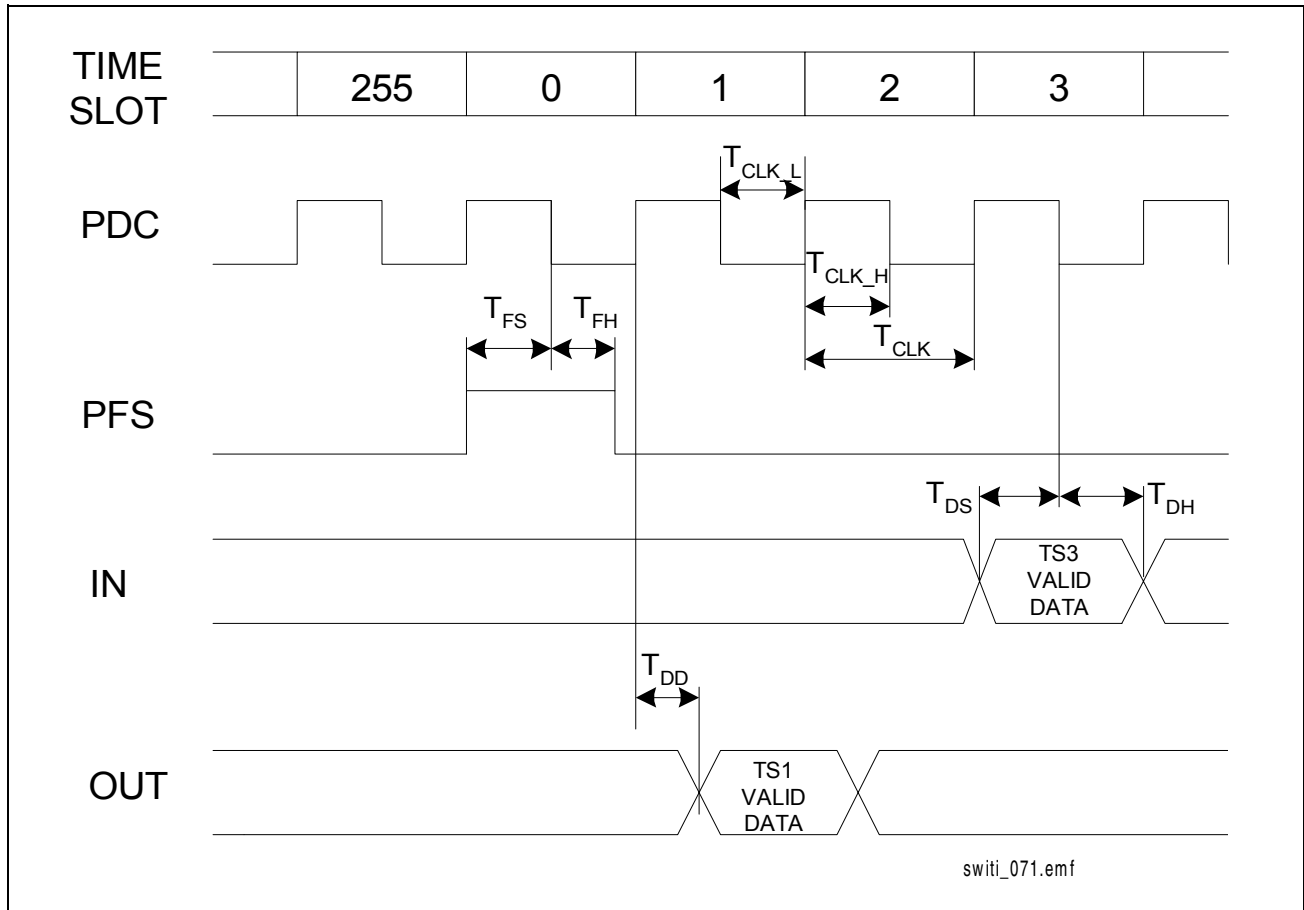

Figure 32 Parallel Mode Timing

Table 23 PCM Parallel Mode Timing

Parameter	Symbol	Limit Values		Unit	Test Condition
		min.	max.		
Frame setup time to clock	T_{FS}	125		ns	
Frame hold time to clock	T_{FH}	125		ns	
Input data setup time	T_{DS}	50		ns	
Input data hold time	T_{DH}	15		ns	
Output data delay	T_{DD}		35	ns	
PDC clock period	T_{CLK}	483	493	ns	PDC = 2.048 MHz
PDC clock period high	T_{CLK_H}	231	257	ns	
PDC clock period low	T_{CLK_L}	231	257	ns	

7.3 Microprocessor Interface Timing

Microprocessor accesses of the SWITL are performed by an activation of the address and \overline{CS} .

- By driving the MODE16 pin 'low' the user selects the 8-bit microprocessor interface, by driving it 'high' - the 16-bit microprocessor interface.
- By driving the ALE pin 'high' the user selects Intel/Infineon mode, by driving it 'low' - Motorola mode. The pin is sampled during the hardware reset process.
- In Intel/Infineon mode, a distinction is needed between working in multiplexed address/data bus mode and de-multiplexed address and data bus mode. In Motorola mode, only de-multiplexed busses are used. By driving the ALE pin 'high' during the normal operation the user selects the de-multiplexed mode, a falling or rising edge during the normal operation selects the multiplexed mode.

7.3.1 Infineon/Intel Timing in De-Multiplexed Mode

In this mode driving \overline{RD} 'low' causes a read access, driving \overline{WR} 'low' causes a write access.

In de-multiplexed bus configuration, ALE must be driven 'high'.

Table 24 Infineon/Intel Timing in De-Multiplexed Mode

Parameter	Symbol	Limit Values ($C_{LOAD}= 50pF$)	
		min	max
Address setup time to \overline{WR} or \overline{RD}	t_{AS}	15 ns	
\overline{RD} pulse width	t_{RR}	60 ns	
\overline{RD} recovery time	t_{RI}	120 ns	
Data output delay from \overline{RD} active	t_{RD}		60 ns
Data float delay from \overline{RD} inactive	t_{DF}		15 ns
\overline{WR} pulse width	t_{WW}	40 ns	
\overline{WR} recovery time	t_{WI}	120 ns	
Data setup time to $\overline{WR} \times \overline{CS}$	t_{DW}	20 ns	
Data hold time from $\overline{WR} \times \overline{CS}$	t_{WD}	10 ns	

Note: The read/write recovery time (t_{RI} and t_{WI}) are required only for consecutive accesses to the microprocessor interface

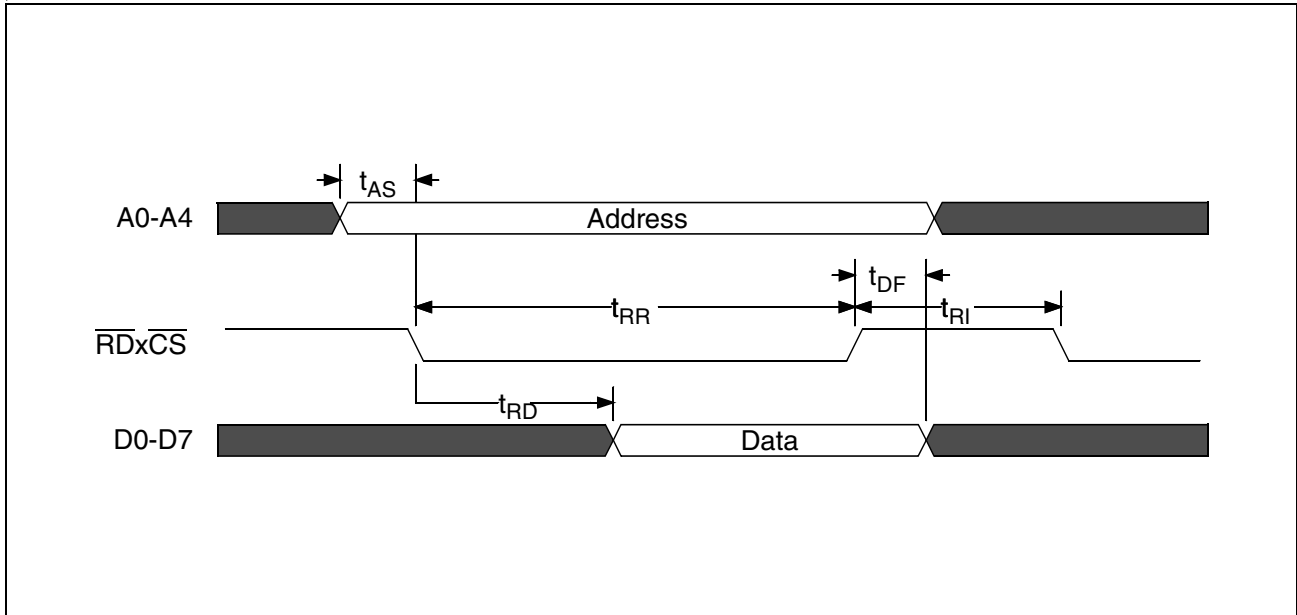

Figure 33 Infineon/Intel Read Cycle in De-Multiplexed Mode

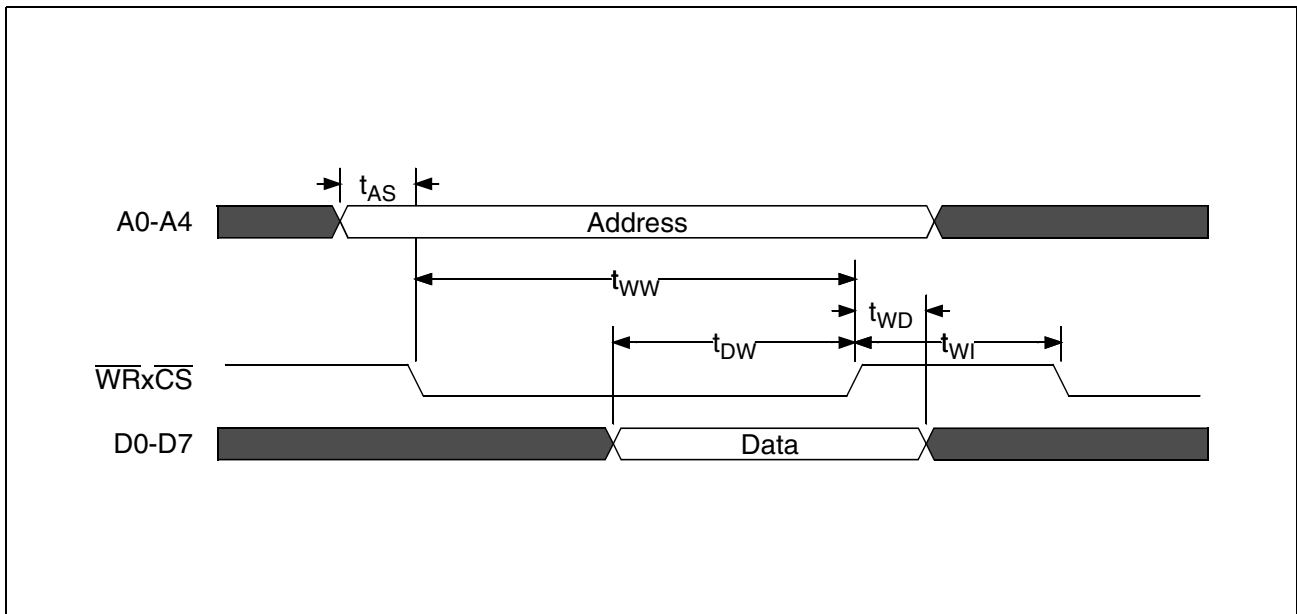

Figure 34 Infineon/Intel Write Cycle in De-Multiplexed Mode

Addresses will be latched with the falling \overline{WR} edge during the write cycle internally.

7.3.2 Infineon/Intel Timing in Multiplexed Mode

In this mode the ALE pin is used to lock the address send via the multiplexed A/D bus.

Table 25 Infineon/Intel Timing in Multiplexed Mode

Parameter	Symbol	Limit Values ($C_{LOAD} = 50pF$)	
		min	max
ALE pulse width	t_{AA}	15 ns	
Address setup time to ALE falling edge	t_{AL}	15 ns	
Address hold time from ALE falling edge	t_{LA}	5 ns	
Address latch setup time to \overline{WR} , \overline{RD}	t_{ALS}	5 ns	
\overline{RD} pulse width	t_{RR}	60 ns	
\overline{RD} recovery time	t_{RI}	120 ns	
Data output delay from \overline{RD} active	t_{RD}		60 ns
Data float delay from \overline{RD} inactive	t_{DF}		15 ns
\overline{WR} pulse width	t_{WW}	40 ns	
\overline{WR} recovery time	t_{WI}	120 ns	
Data setup time to $\overline{WR} \times \overline{CS}$	t_{DW}	20 ns	
Data hold time from $\overline{WR} \times \overline{CS}$	t_{WD}	10 ns	

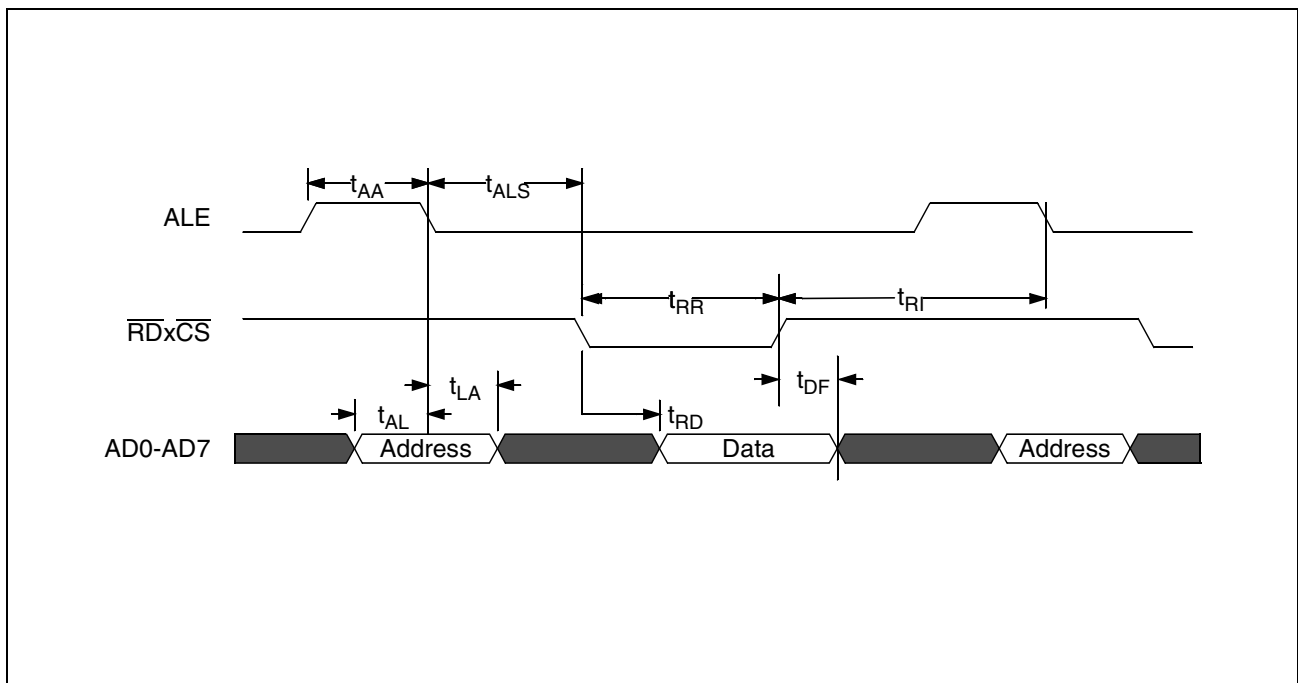

Figure 35 Infineon/Intel Read Cycle in Multiplexed Mode

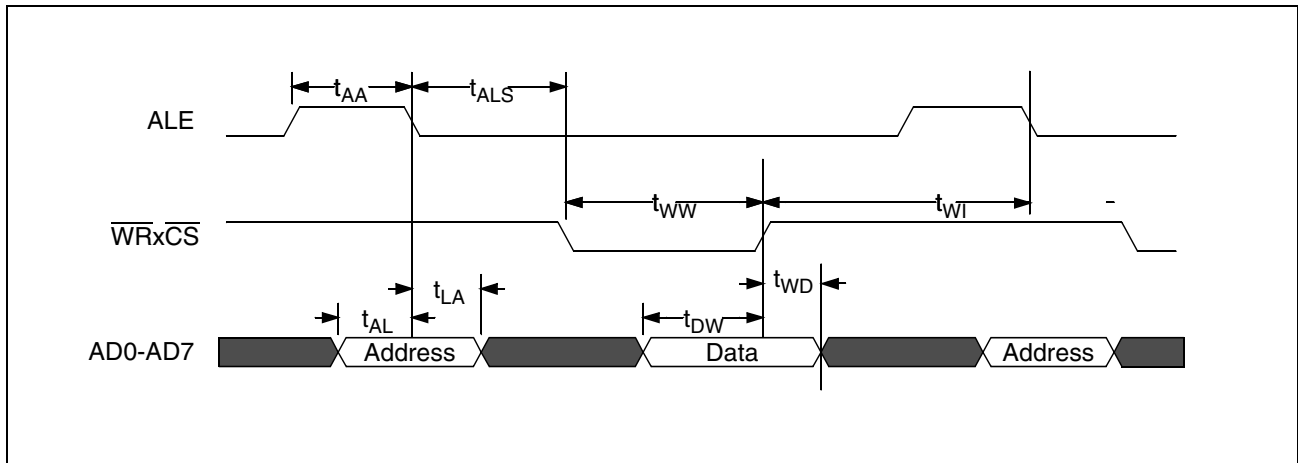

Figure 36 Infineon/Intel Write Cycle in Multiplexed Mode

7.3.3 Motorola Microprocessor Timing

In this mode $\overline{R/\overline{W}}$ distinguishes between Read and Write interactions, and \overline{DS} is used for timing. $\overline{DS} \times \overline{CS}$ is active (low) when both, \overline{DS} and \overline{CS} , are active (low).

The ALE pin must be driven 'low'.

Table 26 Motorola Timing

Parameter	Symbol	Limit Values ($C_{LOAD} = 50pF$)	
		min	max
Address setup time to $\overline{CS} \times \overline{DS}$	t_{AS}	15 ns	
R or \overline{W} setup to \overline{DS}	t_{DSD}	0	
$\overline{R/\overline{W}}$ hold from $\overline{CS} \times \overline{DS}$ inactive	t_{RWD}	0	
R pulse width	t_{RR}	60 ns	
R recovery time	t_{RI}	120 ns	
Data output delay from R	t_{RD}		60 ns
Data float delay from R	t_{DF}		15 ns
\overline{W} pulse width	t_{WW}	40 ns	
\overline{W} recovery time	t_{WI}	120 ns	
Data setup time to \overline{W} and \overline{CS} , \overline{DS} and \overline{CS}	t_{DW}	10 ns	
Data hold time from \overline{W} and \overline{CS} , \overline{DS} and \overline{CS}	t_{WD}	10 ns	

Note: $\overline{DS} \times \overline{CS}$ is active (low) when, both, \overline{DS} and \overline{CS} are active (low)

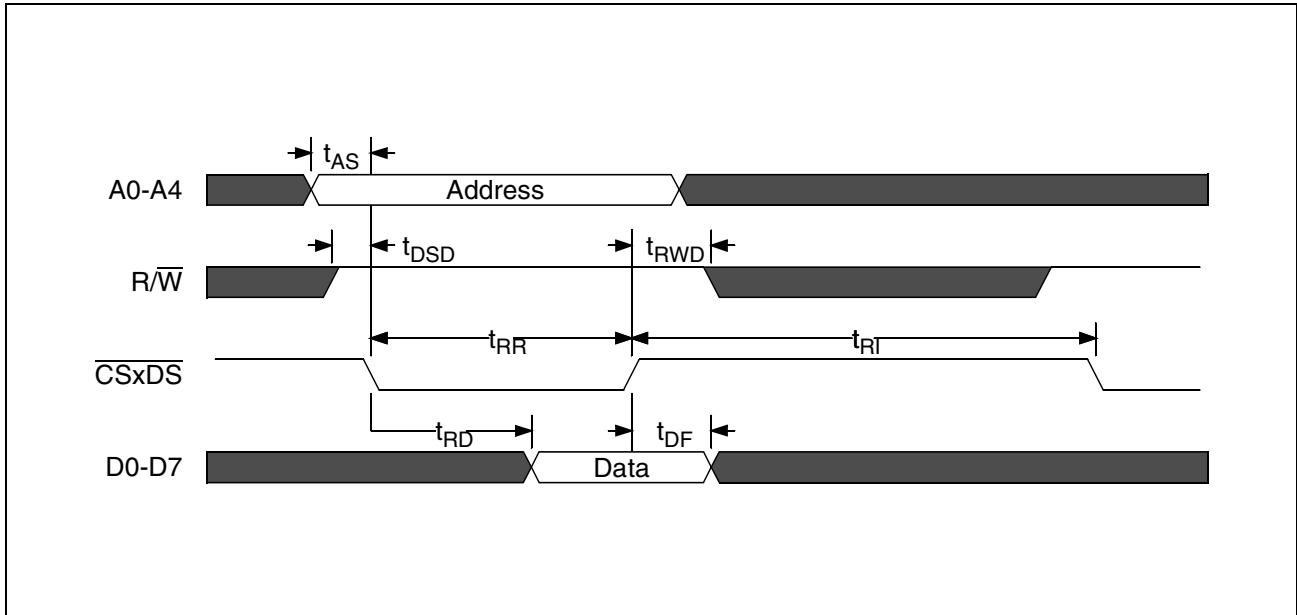

Figure 37 Motorola Read Cycle

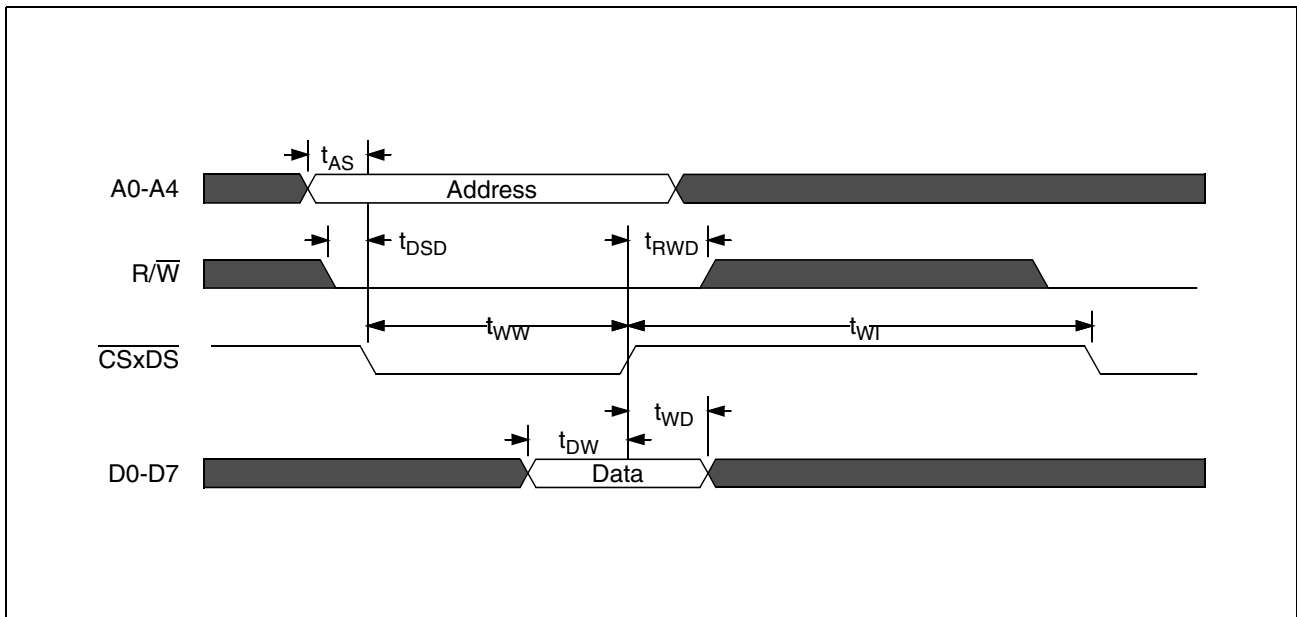

Figure 38 Motorola Write Cycle

7.4 JTAG Interface Timing

Table 27 JTAG Interface Timing

Parameter	Symbol	Limit Values			Unit	Notes
		min.	typ.	max.		
Test Clock (TCK) Period	t_{TCJ}	100			ns	
Test Clock (TCK) Period Low	t_{CJL}	40			ns	
Test Clock (TCK) Period High	t_{CJH}	40			ns	
TMS Set-up time before TCK Rising Edge	t_{SUJ}	5			ns	
TMS Hold time after TCK Rising Edge	t_{HJR}	5			ns	
TDI Set-up time before TCK Rising Edge	t_{DSE}	5			ns	
TDI Hold time after TCK Rising Edge	t_{DHE}	5			ns	
Input Data Set-up time	t_{IPJ}	10			ns	
Input Data Hold time	t_{IAJ}	10			ns	
TDO Delay after TCK Falling Edge	t_{ODF}			20	ns	
Any output pin Delay after TCK Falling Edge	t_{OPD}			25	ns	In Update-DR TAP Controller State
Test Reset	t_{TRST}	1			μ s	

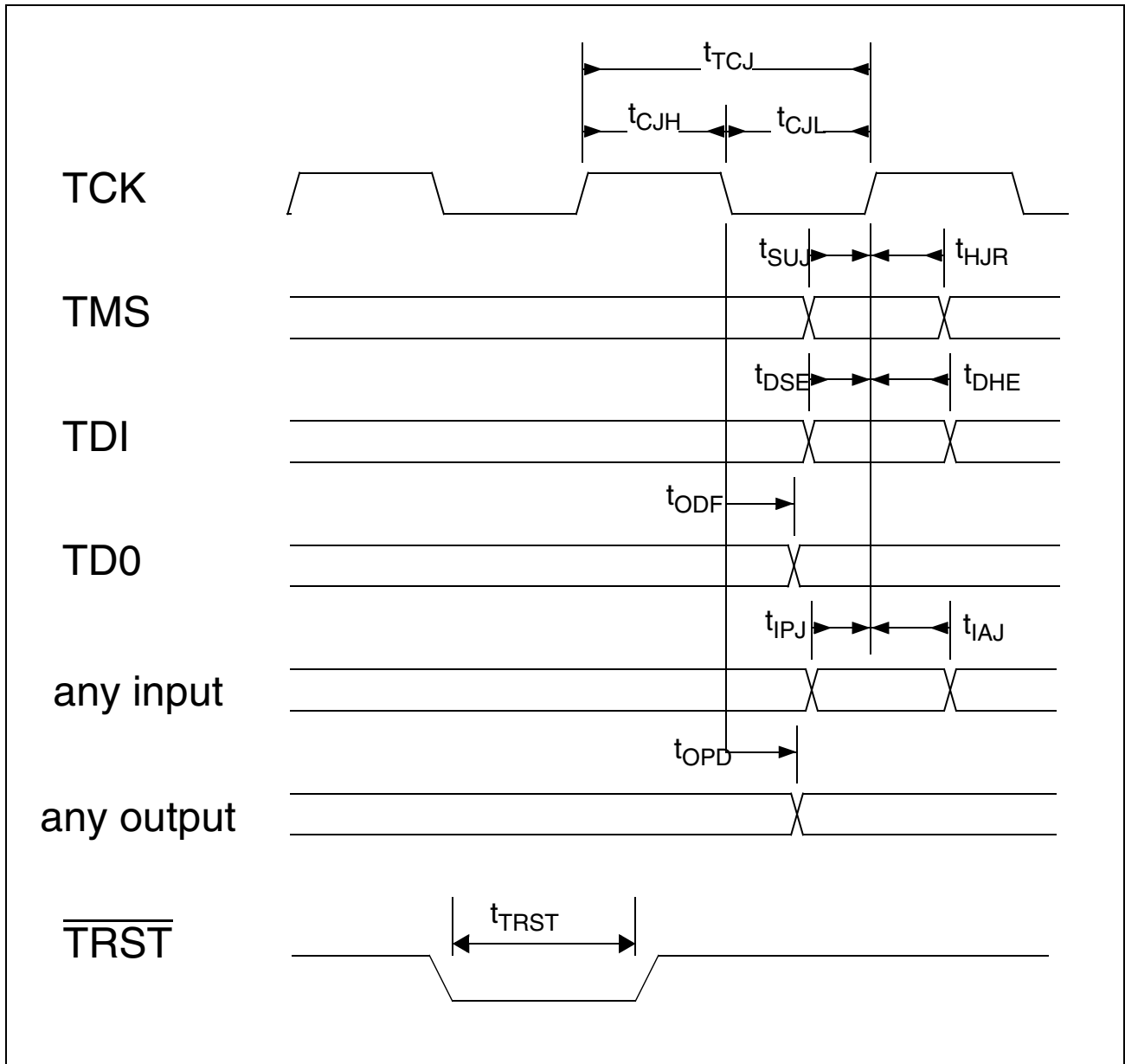

Figure 39 Boundary Scan Timing

7.5 Hardware Reset Timing

Table 28 Hardware Reset Timing

Parameter	Symbol	Limit Values			Unit	Notes
		min.	typ.	max.		
Hardware Reset time	t_{RESET}	1			μs	

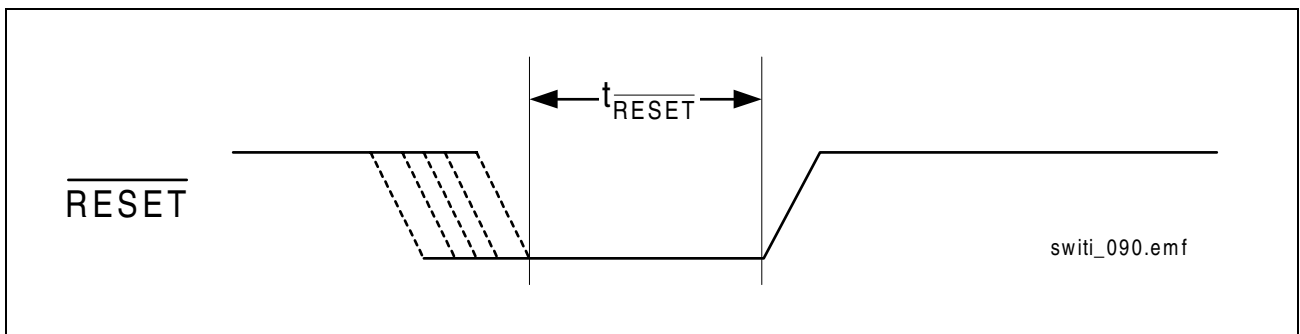

Figure 40 Hardware Reset Timing

8 Electrical Characteristics

8.1 Absolute Maximum Ratings

Table 29 Absolute Maximum Ratings

Parameter	Symbol	Limit Values	Unit
Ambient temperature under bias PEF	T_A	– 40 to 85	°C
Storage temperature	T_{stg}	– 65 to 150	°C
Supply voltage	V_{DD}	– 0.5 to 4.6	V
Voltage on any input or output pin (referenced to ground)	V_S	– 0.5 to 5.5	V
ESD robustness ¹⁾ (HBM: 1.5 kΩ, 100 pF)	$V_{ESD,HBM}$	1500	V

¹⁾ According to MIL-Std 883D, method 3015.7 and ESD Ass. Standard EOS/ESD-5.1-1993.

Note: Stresses above those listed here may cause permanent damage to the device. Exposure to absolute maximum rating conditions for extended periods may affect device reliability. Maximum ratings are absolute ratings; exceeding only one of these values may cause irreversible damage to the integrated circuit.

8.2 Operating Range

Table 30 Operating Range

Parameter	Symbol	Limit Values		Unit
		min.	max.	
Operating temperature	T_A	– 40	85	°C
Supply voltage	V_{DD}	3.13	3.47	V
Ground	V_{SS}	0	0	V
Voltage applied to input pins	V_{IN}	0	5.5	V
Voltage applied to output or I/O pins outputs enabled outputs high-Z	V_{OUT}	0	V_{DD}	V
	V_{OUT}	0	5.5	V

Note: In the operating range, the functions given in the circuit description are fulfilled.

8.3 Crystal Oscillator

The SWITI requires a 16.384 MHz or 32.768 MHz clock source. To supply this a 16.384 MHz or 32.768 MHz crystal can be connected between the ECLKI and ECLKO pins. **Figure 41** shows the crystal with the external capacitors.

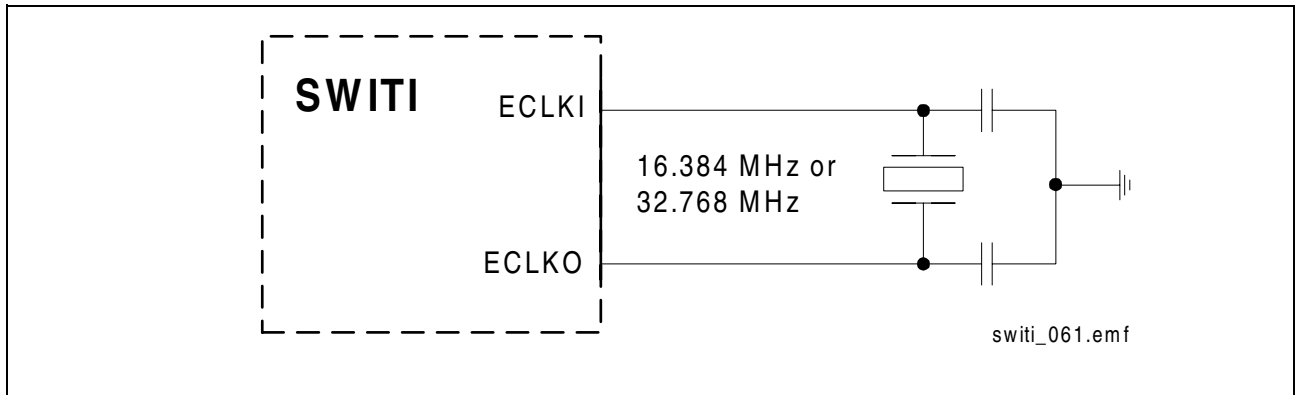

Figure 41 External Crystal

If a crystal is not used, a 16.384 MHz or a 32.768 MHz signal must be provided to the ECLKI pin and ECLKO should be left unconnected.

Table 31 External Capacitances for Crystal (Recommendation)

Parameter	Symbol	Rec. Values	Unit	Notes
Clock external input capacitance	C_{ECLKI}	12	pF	
Clock external output capacitance	C_{ECLKO}	18	pF	

PRELIMINARY

Electrical Characteristics

8.4 DC Characteristics

Table 32 DC Characteristics

Parameter	Symbol	Limit Values		Unit	Notes
		min.	max.		
Input low voltage	V_{IL}	-0.3	0.8	V	
Input high voltage	V_{IH}	2.0	$V_{DD}+3.3$	V	The maximum V_{IH} must not exceed 5.5 V
Output low voltage	V_{OL}		0.4	V	$I_{OL} = 6 \text{ mA}$
Output high voltage	V_{OH}	2.4		V	$I_{OH} = -2.0 \text{ mA}$
Typical power supply current	I_{CC}		200	mA	$V_{DD} = 3.3 \text{ V}$, $T_A = 25 \text{ }^\circ\text{C}$: PDC = 16.384 MHz
Input leakage current	I_{IL}		1	μA	$V_{DD} = 3.3 \text{ V}$, GND = 0 V; all other pins are floating; $V_{IN} = 0 \text{ V}$
Output leakage current	I_{OZ}		1	μA	$V_{DD} = 3.3 \text{ V}$, GND = 0 V; $V_{OUT} = 0 \text{ V}$

Note: The listed characteristics are ensured over the operating range of the integrated circuit. Typical characteristics specify mean values expected over the production spread. If not otherwise specified, typical characteristics apply at $T_A = 25 \text{ }^\circ\text{C}$ and the given supply voltage.

8.5 Capacitances

Table 33 Input/Output Capacitances

Parameter	Symbol	Limit Values	Unit	Notes
		Typ.		
ECLKI input capacitance	C_{ECLKI}	7	pF	$f_C = 1 \text{ MHz}$ The pins, which are not under test, are connected to GND
ECLKO output capacitance	C_{ECLKO}	7	pF	
Input capacitance	C_{IN}	5	pF	
Output capacitance	C_{OUT}	5	pF	

8.6 AC Characteristics

Ambient temperature under bias range, $V_{DD} = 3.3\text{ V} \pm 5\%$.

Inputs are driven to 2.4 V for a logical '1' and to 0.4 V for a logical '0'.

Timing measurements for all other signals are made at 2.0 V for a logical '1' and at 0.8 V for a logical '0'.

The AC-testing input/output wave forms are shown below.

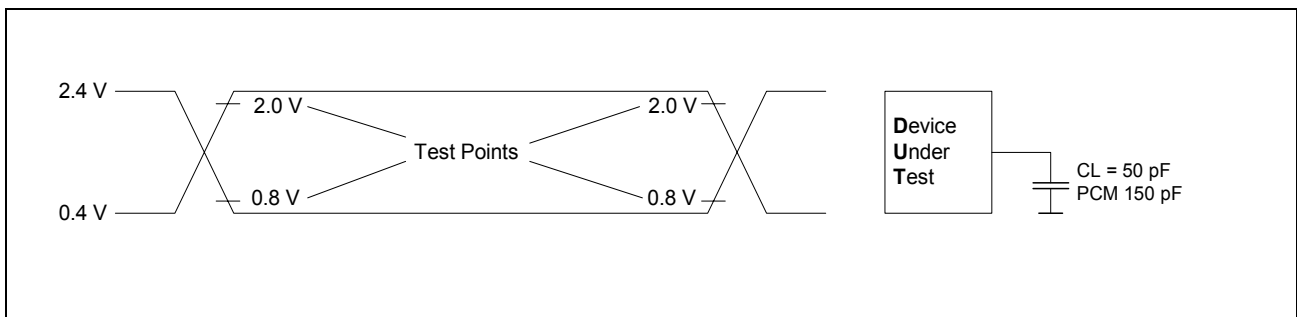

Figure 42 I/O Wave Form for AC-Test

9 Package Outlines

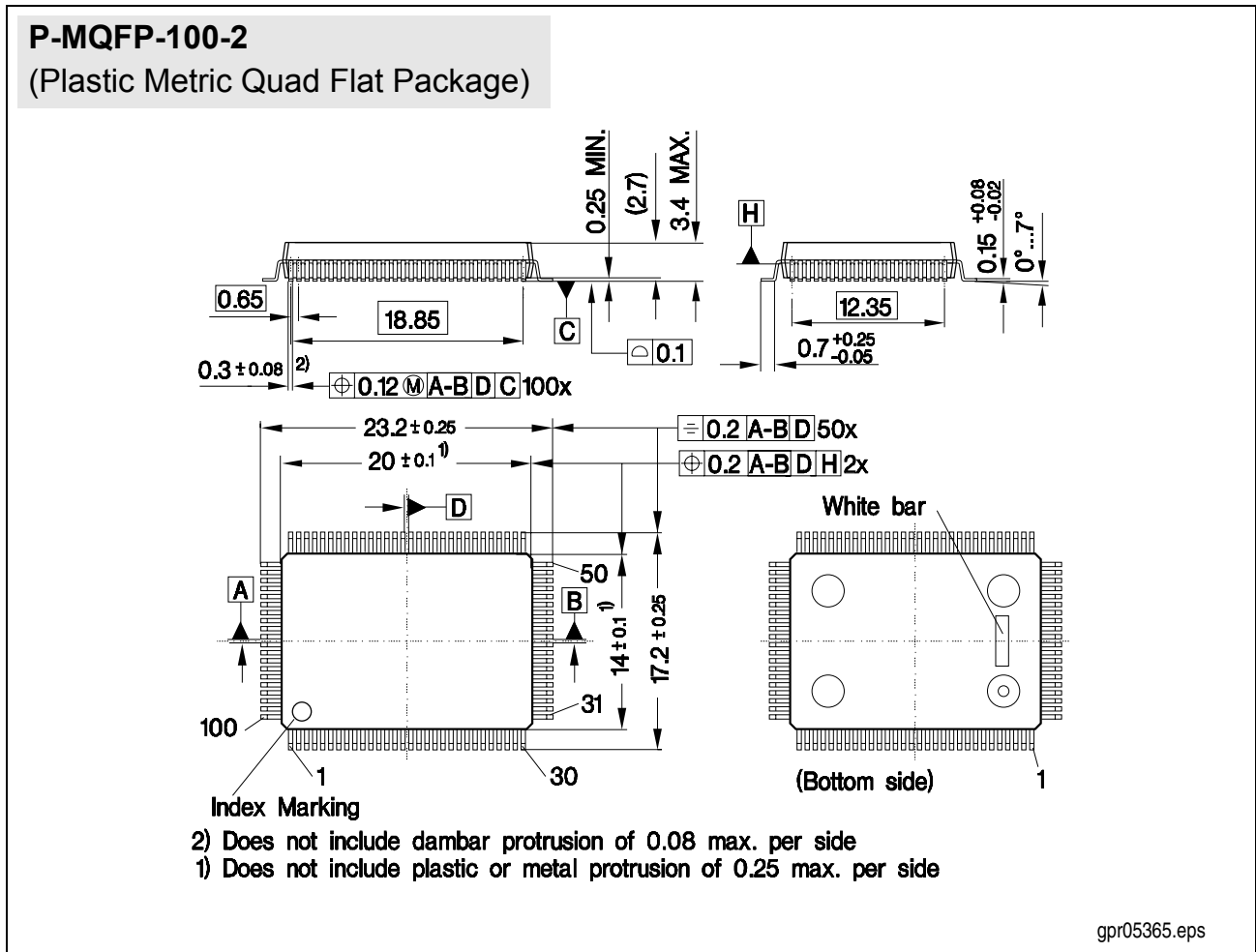

Figure 43 Outlines of P-MQFP-100-2

Sorts of Packing

Package outlines for tubes, trays etc. are contained in our Data Book "Package Information".

SMD = Surface Mounted Device

Dimensions in mm

PRELIMINARY**A**

Analyze Memory 20

B

Bidirectional Switching 18

Boundary Scan 35, 37

Broadcast 7

Broadcast Switching 18

C

Clock Shift 6

Constant Delay 6, 17

D

Data Rate Adaption 6

F

Flexible Data Rates 6

Frame Group 34

Framing Group 7

G

General Purpose Clocks 7, 33

GPIO Port 7, 33

I

Initialization Procedure 82

Input/Output Tolerance 8

Interrupts Masking 75

L

Local Bus Interface 12, 29

M

Message Mode 7

Microprocessor Interface 7, 13, 16, 31

Minimum Delay 6

Multipoint 7

Multipoint Switching 17

P

Parallel Mode 6, 19, 104

PRELIMINARY**R**

Read Access 7

Register

Configuration Command Register 1	49
Configuration Command Register 2	52
Configuration Register	66
Connection Command Register	47, 69
Destination Address Register	68
Destination Port Address Register	42
General Input Register	69
General Input Register 1	44
General Input Register 2	46
General Purpose Direction Register	61
General Purpose Interrupt Register	62
General Purpose Mask Register	62
General Purpose Port Input Register	61
General Purpose Port Output Register	61
IDCODE Register	71
Input Time Slot Address Register	42
Interrupt Error Mask Register 1	60
Interrupt Error Mask Register 2	60
Interrupt Error Status Register	70
Interrupt Error Status Register 1	58
Interrupt Error Status Register 2	58
Interrupt Mask Register 1	59
Interrupt Status Register 1	57
Message Value Register	56
Output Time Slot Address Register	43
Source Address Register	68
Source Port Address Register	42
Sub-Channel Address Register	43
Time-Slot Value / Configuration Register	71
Time-Slot Value Register	63

S

Subchannel Switching 6, 90

W

Write Access 7

Infineon goes for Business Excellence

“Business excellence means intelligent approaches and clearly defined processes, which are both constantly under review and ultimately lead to good operating results.

Better operating results and business excellence mean less idleness and wastefulness for all of us, more professional success, more accurate information, a better overview and, thereby, less frustration and more satisfaction.”

Dr. Ulrich Schumacher

<http://www.infineon.com>