



VIDEO IF AMPLIFIER FOR COLOR AND MONOCHROME TELEVISION RECEIVER

CHMC CD7607CP/CD7611CP

FUNCTION

- Three Controlled IF Amplifier stages
- Video Demodulator Controlled by Picture Carrier
- Black Noise and White Noise Inverter
- Peak AGC
- DC Amplifier for RF AGC Output
- DC Amplifier for AFT
- Quadrature Detector for AFT

Outline Drawing

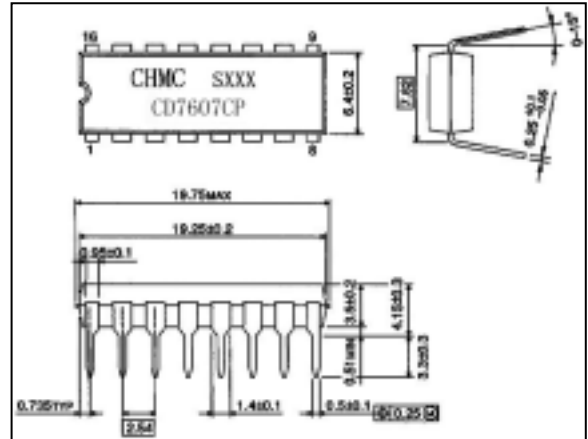

FEATURE

- High Gain, Wide Band IF Amplifier: 50dB(Typ.) at 58MHz
- Gain Reduction with Excellent Stability: 55dB(Typ.) at 58MHz
- Excellent DG/DP Characteristics: DG 7%(Typ.), DP 3.5deg.(Typ.)
- Excellent S/N Characteristics Due to Delayed 3 Stage AGC action.
- Fast AGC Action Due to Noise Inverter and Peak AGC.
- Switch Off the Video part with VTR Switch.
- Dual Differential AFT Output.
- Negative Video Output Signal.

PIN CONNECTION

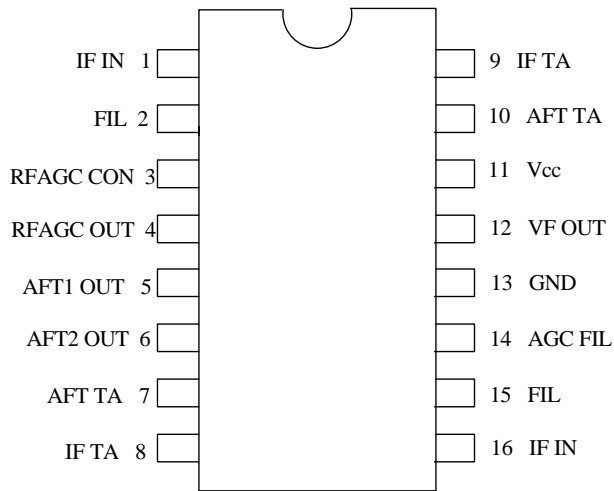

BLOCK DIAGRAM

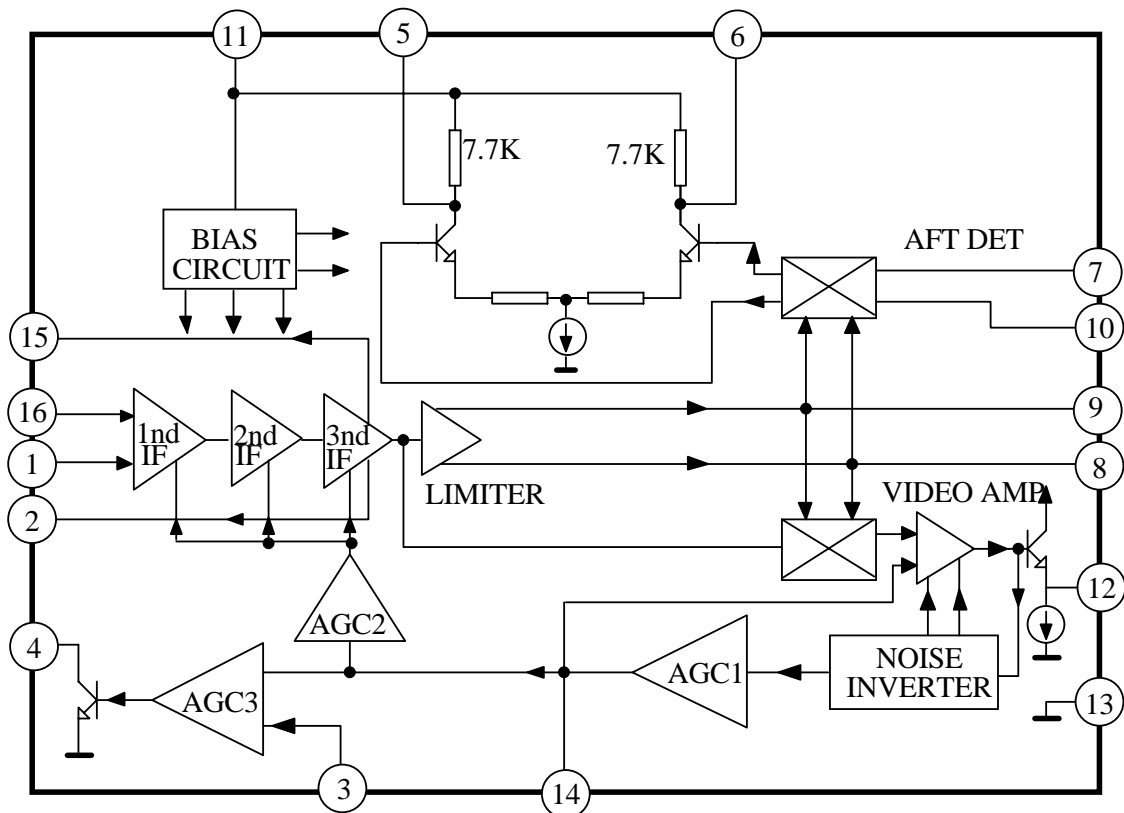

MAXIMUM RATINGS (Ta=25)

CHARACTERISTIC	SYMBOL	RATING	UNIT
Supply Voltage	V _{cc}	15	V
Open Loop Voltage	V ₄	15	V
Video DC Output Current	I ₁₂	6	mA
Power Dissipation (note)	P _D	1.4	W
Ambient Temperature	T _a	-20~65	
Storage Temperature	T _{stg}	-55~150	

(Note) Derated above Ta=25 in the proportion of 11.2mW/

ELECTRICAL CHARACTERISTICS (Ta=25)

CHARACTERISTIC	SYMBOL	TEST CIRCUIT	TEST CONDITION	MIN.	TYP.	MAX.	UNIT
Recommended Supply Voltage	V _{cc} (V11)	-	-	10.8	12.0	13.2	V
Supply Current	I _{cc} (I11)	1	V _{cc} =12V	42	51	63	mA
VIDEO DC Output Voltage	V ₁₂	1	V _{cc} =12V	5.2	5.5	5.8	V
AFT DC Output Voltage	V ₅	1	V _{cc} =12V SW ₁ :ON, SW ₂ :ON	5.3	6.8	8.3	V
AFT DC Output Voltage	V ₆	1	V _{cc} =12V SW ₁ :ON, SW ₂ :ON	5.3	6.8	8.3	V
AFT Output Offset Voltage	V _{5-V6}	1	V _{cc} =12V SW ₁ :ON, SW ₂ :ON	-1.5	0	1.5	V
RF AGC Residual Output Voltage	V ₄ SAT	1	V _{cc} =12V, SW ₃ :2 SW ₄ :1—D7607 SW ₄ :2—D7611	-	-	0.5	V
RF AGC Leak Current	I ₄ LEAK		V _{cc} =12V, SW ₃ :1 SW ₄ :1—D7611 SW ₄ :2—D7607	-	-	1	μA
Video Sensitivity	V _i Pin1-16	2	V _{cc} =12V, fp=58.75MHz V ₁₂ =0.8V _{p-p} , AM:30%	100	200	300	μV _{rms}
AGC Range	A (IF)	2	V _{cc} =12V, fp=58.75MHz V ₁₄ =11.5V 4.0V	60	64	-	dB
Sync Tip Level Voltage	V _{SYNC} (V12)	2	V _{cc} =12V, fp=58.75MHz	2.3	2.5	2.7	V
Maximum IF Input Voltage	V _{IN MAX} PIF	2	V _{cc} =12V, fp=58.75MHz	100	120	-	mV _{rms}
White Noise Threshold	V _{w TH} (V12)	2	V _{cc} =12V, fp=58.75MHz	5.8	6.2	6.6	V
White Noise Clamp Level	V _{w CL} (V12)	2	V _{cc} =12V, fp=58.75MHz	3.7	4.1	4.5	V

ELECTRICAL CHARACTERISTICS

CONTINUE

CHARACTERISTIC	SYM-BOL	TEST CIRCUIT	TEST CONDITION	MIN.	TYP.	MAX.	UNIT
Black Noise Threshold	V _{B TH} (V12)	2	V _{cc} =12V, f _p =58.75MHz	1.4	1.6	1.8	V
Black Noise Clamp Level	V _{B CL} (V12)	2	V _{cc} =12V, f _p =58.75MHz	2.9	3.3	3.7	V
Video Frequency Response	f _{BW}	2	Input 58.75MHz +Sweep Generator	4.5	5.5	-	MHz
Suppression of carrier		4	SG1=100mVrms SG2, SG3 OFF	40	50	-	dB
Suppression of 2 nd carrier	I2nd	4	SG1=100mVrms SG2, SG3 OFF	40	50	-	dB
Suppression of Sound Carrier Color Subcarrier	I920	4	SG1=100mVrms SG2=32mVrms SG3=32mVrms	33	38	-	dB
Differential Phase	DP	3	-	-	3.5	5	deg
Differential Gain	DG	3	(Note 10)	-	7	10	%
Input Impedance	R _{IN}	-	f=58.75MHz Between Pin16-1	3.0	4.5	6.0	k
	C _{IN}			-	2.0	5.0	pF
AFT Sensitivity	F/ V5-6	2	f=58.75MHz	-	16	-	kHz/V
AFT Output Upper Voltage	V5, V6 U	2	f=58.75MHz	11.7	11.9	12.0	V
AFT Output Lower Voltage	V5, V6 L	2	f=58.75MHz	1.8	2.3	2.8	V
Max Available Current	I4 MAX	-	D7607	0.3	-	-	mA
			D7611	7	-	-	mA
RF AGC Delay Point Range	V _{IN} Delay	-	f=58.75MHz	-	-	-	--

TEST CIRCUIT

1.DC TEST CIRCUIT

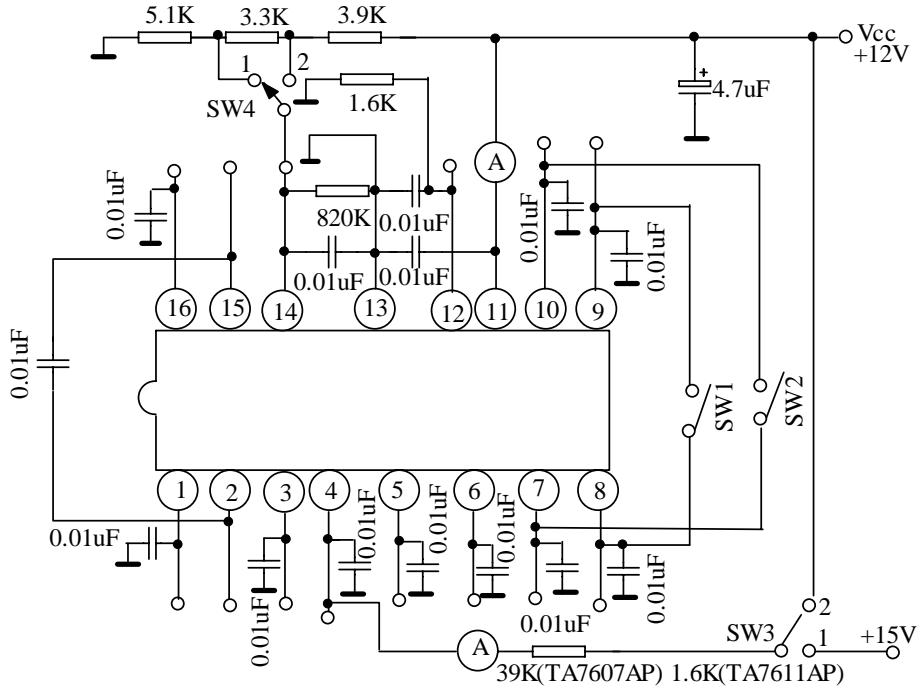

2.DYNAMIC TEST CIRCUIT

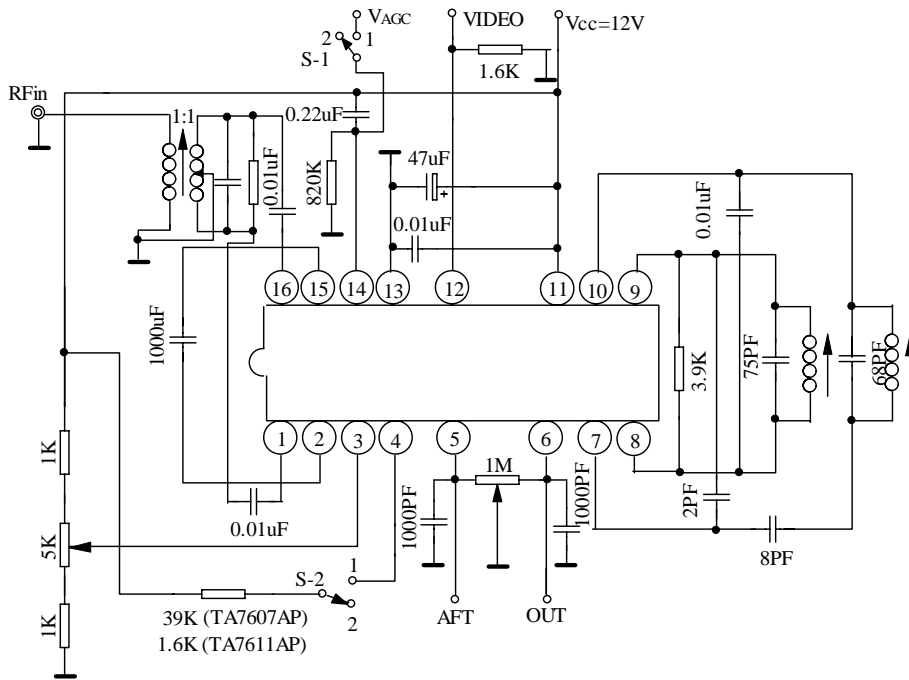

3.DG DP TEST CIRCUIT

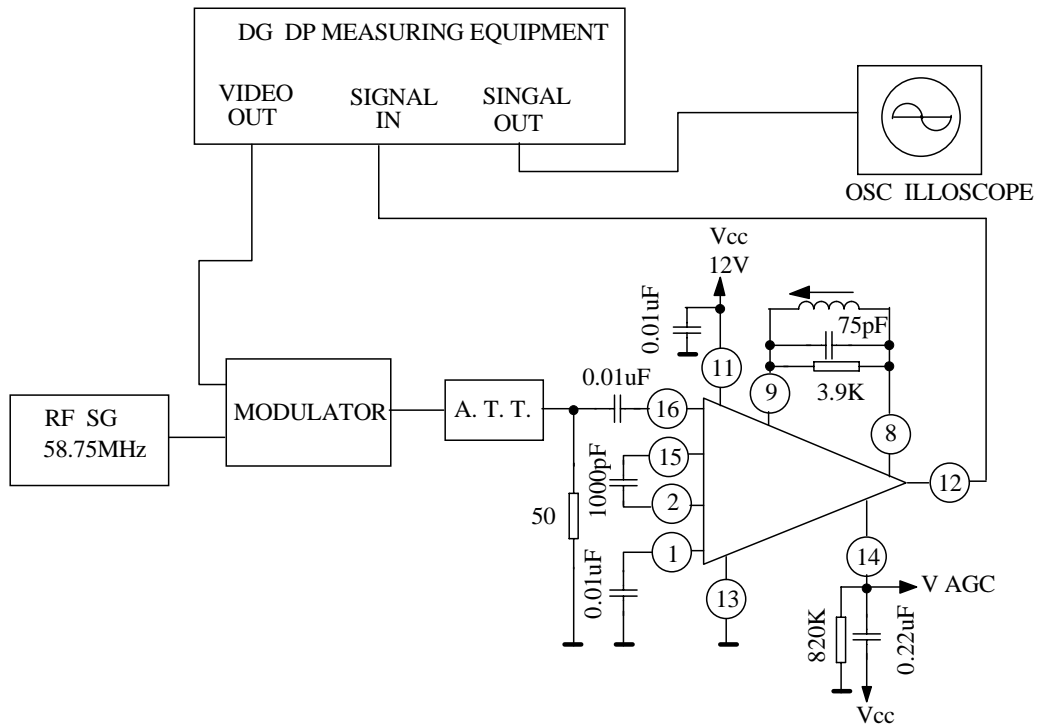

V_{AGC} : GAIN REDUCTION 40Db ADJUST
 A.T.T : SYNC TIP LEVEL DC 2.5V ADJUST
 A.P.L : 50%

4.INTER MODULATION TEST CIRCUIT

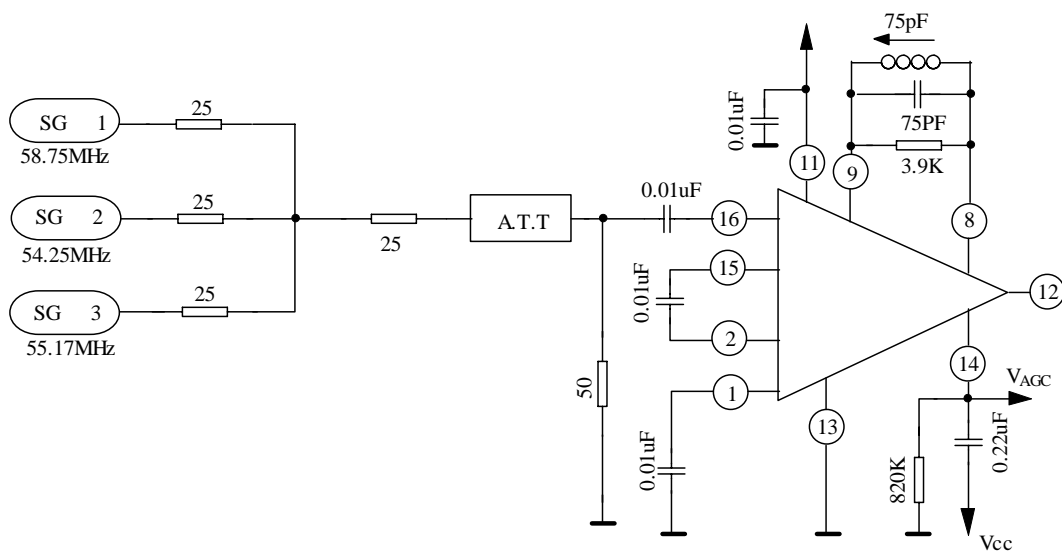

APPLICATION CIRCUIT

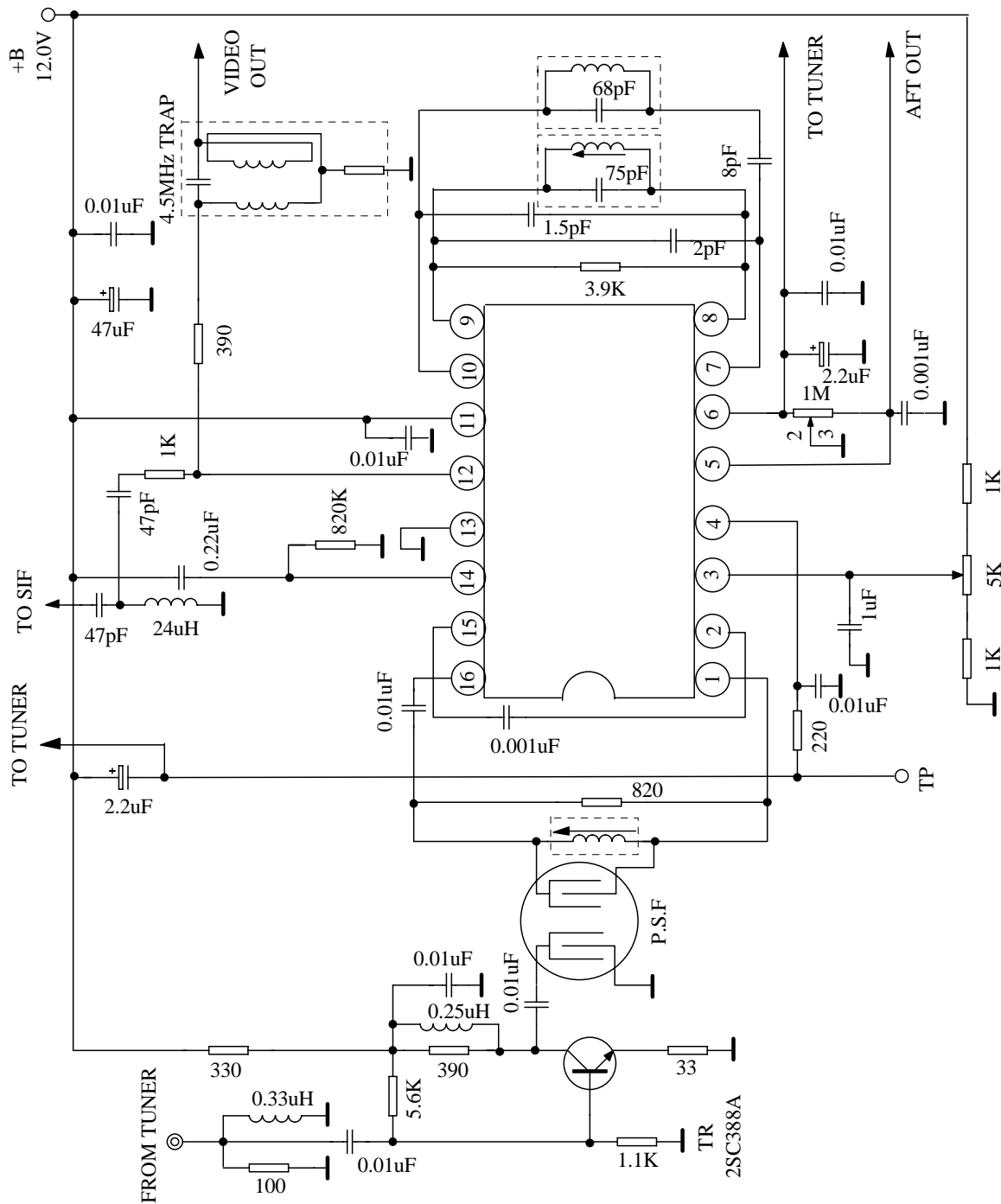

CHARACTERISTIC CURVES

AFT OUTPUT VOLTAGE AS A FUNCTION OF FREQUENCY FOR THE CD7607CP/CD7611CP

