

TOSHIBA CMOS DIGITAL INTEGRATED CIRCUIT SILICON MONOLITHIC

TC4021BP, TC4021BF, TC4021BFN

TC4021B 8-STAGE STATIC SHIFT REGISTER (ASYNCHRONOUS PARALLEL INPUT OR SYNCHRONOUS SERIAL INPUT/SERIAL OUTPUT)

TC4021B is 8 stage parallel in / serial out shift register, which can be used also for serial in / serial out operations. In the case of parallel operation, the data of PARALLEL IN is input to each F/F asynchronously with CLOCK and the output is obtained. In the case of serial operations, each F/F is triggered by rising edge of CLOCK. (ASYNCHRONOUS PARALLEL OR SYNCHRONOUS SERIAL INPUT)

Switching of PARALLEL operation and SERIAL operation is achieved by P/ \bar{S} CONTROL input. When P/ \bar{S} CONTROL input is "H", PARALLEL operation is designated and when it is "L", SERIAL operation is designated.

(Note) The JEDEC SOP (FN) is not available in Japan.

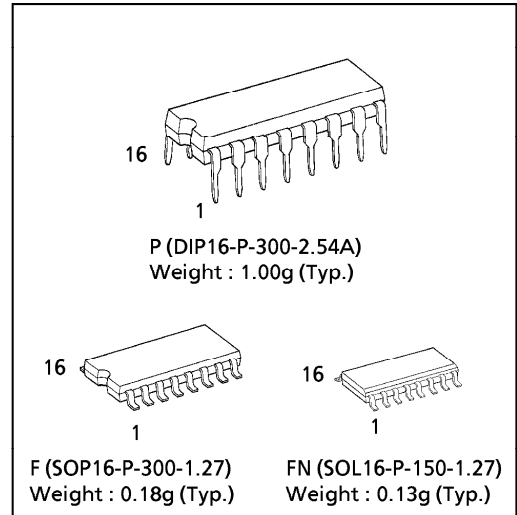

MAXIMUM RATINGS

CHARACTERISTIC	SYMBOL	RATING	UNIT
DC Supply Voltage	V_{DD}	$V_{SS} - 0.5 \sim V_{SS} + 20$	V
Input Voltage	V_{IN}	$V_{SS} - 0.5 \sim V_{DD} + 0.5$	V
Output Voltage	V_{OUT}	$V_{SS} - 0.5 \sim V_{DD} + 0.5$	V
DC Input Current	I_{IN}	± 10	mA
Power Dissipation	P_D	300 (DIP) / 180 (SOIC)	mW
Operating Temperature Range	T_{opr}	-40~85	°C
Storage Temperature Range	T_{stg}	-65~150	°C

PIN ASSIGNMENT

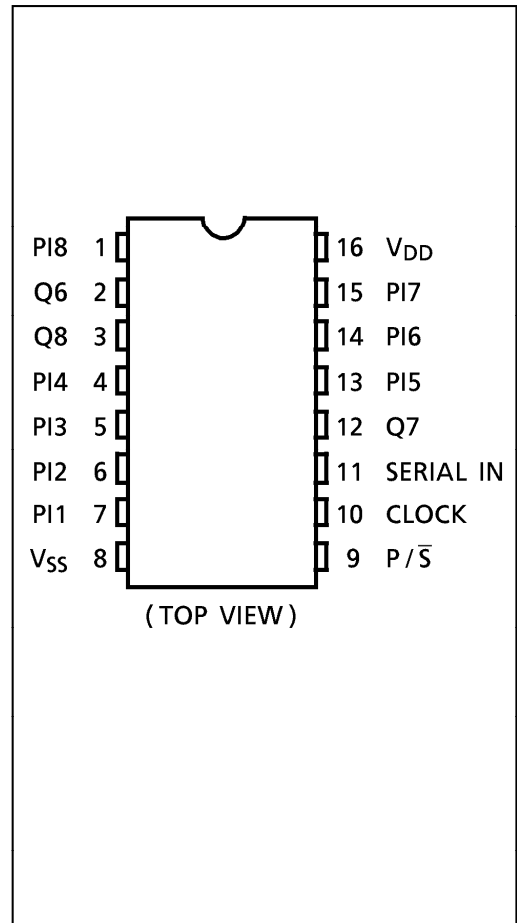

TRUTH TABLE

CLOCK $\Delta\Delta$	INPUTS				OUTPUTS Δ	
	P/ \bar{S}	PI1	PI _n	SI	Q1	Q _n
	L	※	※	L	L	Q _n - 1
	L	※	※	H	H	Q _n - 1
	L	※	※	※	No Change	
※	H	L	L	※	L	L
※	H	L	H	※	L	H
※	H	H	L	※	H	L
※	H	H	H	※	H	H

n : 2 ~ 8
 Δ : Q1 ~ Q5 Internal
 $\Delta\Delta$: Level Change
 ※ : Don't Care

961001EBA2

● TOSHIBA is continually working to improve the quality and the reliability of its products. Nevertheless, semiconductor devices in general can malfunction or fail due to their inherent electrical sensitivity and vulnerability to physical stress. It is the responsibility of the buyer, when utilizing TOSHIBA products, to observe standards of safety, and to avoid situations in which a malfunction or failure of a TOSHIBA product could cause loss of human life, bodily injury or damage to property. In developing your designs, please ensure that TOSHIBA products are used within specified operating ranges as set forth in the most recent products specifications. Also, please keep in mind the precautions and conditions set forth in the TOSHIBA Semiconductor Reliability Handbook.

LOGIC DIAGRAM

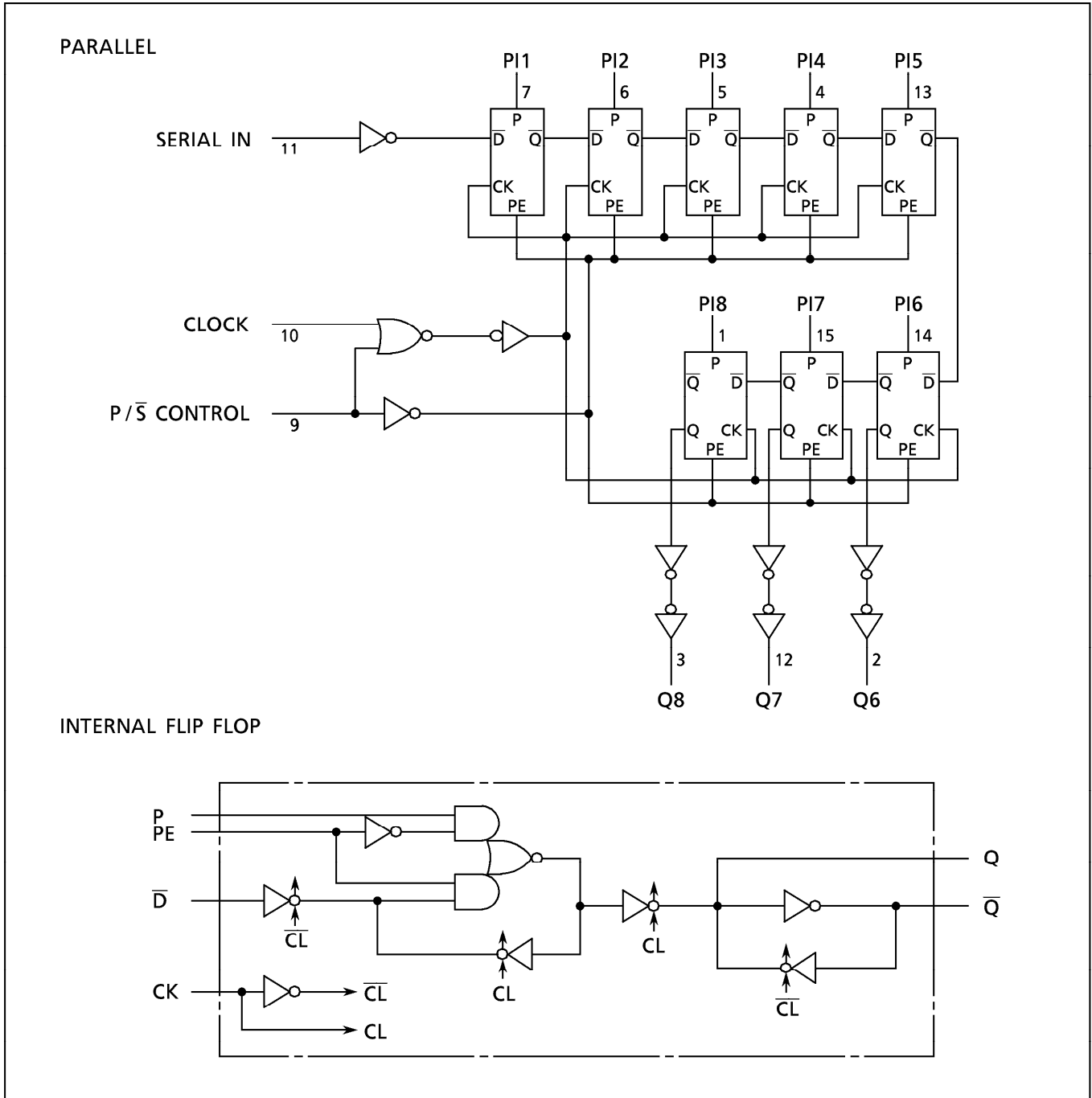

961001EBA2'

- The products described in this document are subject to foreign exchange and foreign trade control laws.
- The information contained herein is presented only as a guide for the applications of our products. No responsibility is assumed by TOSHIBA CORPORATION for any infringements of intellectual property or other rights of the third parties which may result from its use. No license is granted by implication or otherwise under any intellectual property or other rights of TOSHIBA CORPORATION or others.
- The information contained herein is subject to change without notice.

RECOMMENDED OPERATING CONDITIONS ($V_{SS} = 0V$)

CHARACTERISTIC	SYMBOL	TEST CONDITION	MIN.	TYP.	MAX.	UNIT
DC Supply Voltage	V_{DD}		3	—	18	V
Input Voltage	V_{IN}		0	—	V_{DD}	V

STATIC ELECTRICAL CHARACTERISTICS ($V_{SS} = 0V$)

CHARACTERISTIC	SYM-BOL	TEST CONDITION	V_{DD} (V)	- 40°C		25°C			85°C		UNIT	
				MIN.	MAX.	MIN.	TYP.	MAX.	MIN.	MAX.		
High-Level Output Voltage	V_{OH}	$ I_{OUT} < 1\mu A$ $V_{IN} = V_{SS}, V_{DD}$	5	4.95	—	4.95	5.00	—	4.95	—	V	
			10	9.95	—	9.95	10.00	—	9.95	—		
			15	14.95	—	14.95	15.00	—	14.95	—		
Low-Level Output Voltage	V_{OL}	$ I_{OUT} < 1\mu A$ $V_{IN} = V_{SS}, V_{DD}$	5	—	0.05	—	0.00	0.05	—	0.05	V	
			10	—	0.05	—	0.00	0.05	—	0.05		
			15	—	0.05	—	0.00	0.05	—	0.05		
Output High Current	I_{OH}	$V_{OH} = 4.6V$ $V_{OH} = 2.5V$ $V_{OH} = 9.5V$ $V_{OH} = 13.5V$ $V_{IN} = V_{SS}, V_{DD}$	5	-0.61	—	-0.51	-1.0	—	-0.42	—	mA	
			5	-2.50	—	-2.10	-4.0	—	-1.70	—		
			10	-1.50	—	-1.30	-2.2	—	-1.10	—		
			15	-4.00	—	-3.40	-9.0	—	-2.80	—		
Output Low Current	I_{OL}	$V_{OL} = 0.4V$ $V_{OL} = 0.5V$ $V_{OL} = 1.5V$ $V_{IN} = V_{SS}, V_{DD}$	5	0.61	—	0.51	1.5	—	0.42	—	mA	
			10	1.50	—	1.30	3.8	—	1.10	—		
			15	4.00	—	3.40	15.0	—	2.80	—		
Input High Voltage	V_{IH}	$V_{OUT} = 0.5V, 4.5V$ $V_{OUT} = 1.0V, 9.0V$ $V_{OUT} = 1.5V, 13.5V$ $ I_{OUT} < 1\mu A$	5	3.5	—	3.5	2.75	—	3.5	—	V	
			10	7.0	—	7.0	5.50	—	7.0	—		
			15	11.0	—	11.0	8.25	—	11.0	—		
Input Low Voltage	V_{IL}	$V_{OUT} = 0.5V, 4.5V$ $V_{OUT} = 1.0V, 9.0V$ $V_{OUT} = 1.5V, 13.5V$ $ I_{OUT} < 1\mu A$	5	—	1.5	—	2.25	1.5	—	1.5	V	
			10	—	3.0	—	4.50	3.0	—	3.0		
			15	—	4.0	—	6.75	4.0	—	4.0		
Input Current	"H" Level	I_{IH}	$V_{IH} = 18V$	18	—	0.1	—	10^{-5}	0.1	—	1.0	μA
	"L" Level	I_{IL}	$V_{IL} = 0V$	18	—	-0.1	—	-10^{-5}	-0.1	—	-1.0	
Quiescent Supply Current	I_{DD}	$V_{IN} = V_{SS}, V_{DD} *$	5	—	5	—	0.005	5	—	150	μA	
			10	—	10	—	0.010	10	—	300		
			15	—	20	—	0.020	20	—	600		

* All valid input combinations.

DYNAMIC ELECTRICAL CHARACTERISTICS (Ta = 25°C, Vss = 0V, CL = 50pF)

CHARACTERISTIC	SYMBOL	TEST CONDITION	V _{DD} (V)	MIN.	TYP.	MAX.	UNIT
Output Transition Time (Low to High)	t _{TLH}		5	—	80	200	ns
			10	—	50	100	
			15	—	40	80	
Output Transition Time (High to Low)	t _{THL}		5	—	80	200	ns
			10	—	50	100	
			15	—	40	80	
Propagation Delay Time (CLOCK - Q)	t _{pLH} t _{pHL}		5	—	150	320	ns
			10	—	65	160	
			15	—	45	120	
Propagation Delay Time (P / \bar{S} - Q)	t _{pLH} t _{pHL}		5	—	230	460	ns
			10	—	90	180	
			15	—	60	120	
Max. Clock Frequency	f _{CL}		5	3.0	6.5	—	MHz
			10	6.0	18.0	—	
			15	8.5	24.0	—	
Min. Clock Pulse Width	t _w		5	—	80	180	ns
			10	—	30	80	
			15	—	20	50	
Max. Clock Rise Time Max. Clock Fall Time	t _{rCL} t _{fCL}		5	20.0	—	—	μs
			10	2.5	—	—	
			15	1.0	—	—	
Min. Set-up Time (SI - CLOCK)	t _{su}		5	—	40	120	ns
			10	—	20	80	
			15	—	15	60	
Min. Set-up Time (PI - P / \bar{S})	t _{su}		5	—	25	50	ns
			10	—	15	30	
			15	—	10	20	
Min. Hold Time (SI - CLOCK), (PI - P / \bar{S})	t _H		5	—	35	70	ns
			10	—	20	40	
			15	—	15	30	
Min. Pulse Width (P / \bar{S} - CONTROL)	t _{WH}		5	—	90	180	ns
			10	—	30	80	
			15	—	10	50	
Min. Removal Time (P / \bar{S} - CLOCK)	t _{rem}		5	—	45	280	ns
			10	—	20	140	
			15	—	15	100	
Input Capacitance	C _{IN}			—	5	7.5	pF

WAVEFORMS FOR MEASUREMENT OF DYNAMIC CHARACTERISTICS

WAVEFORM 1

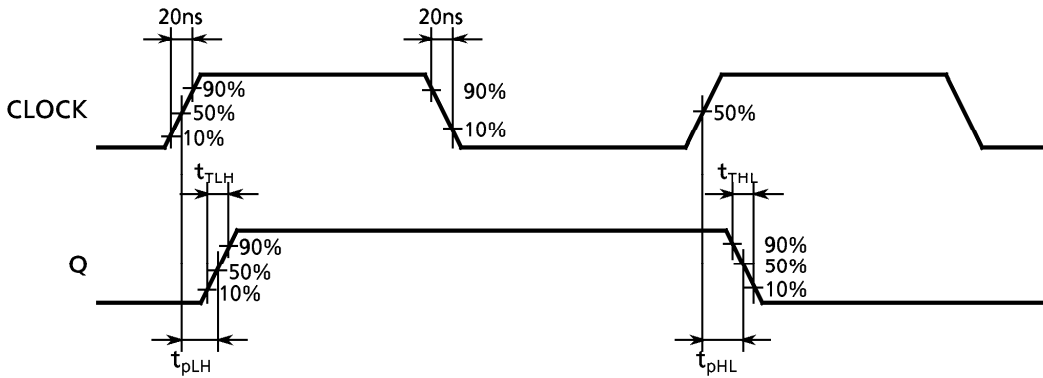

WAVEFORM 2

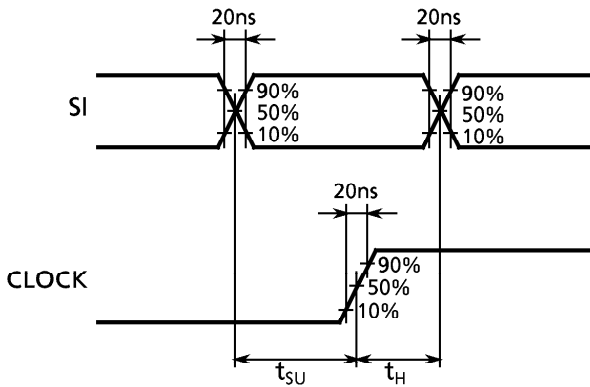

WAVEFORM 3

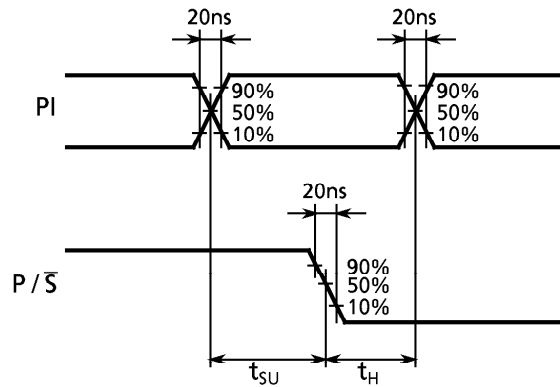

WAVEFORM 4

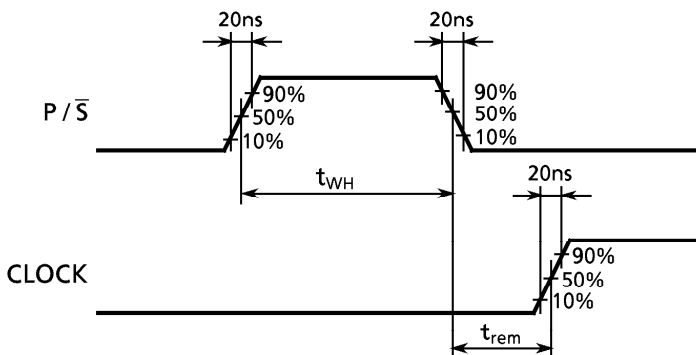

DIP 16PIN OUTLINE DRAWING (DIP16-P-300-2.54A)

Unit in mm

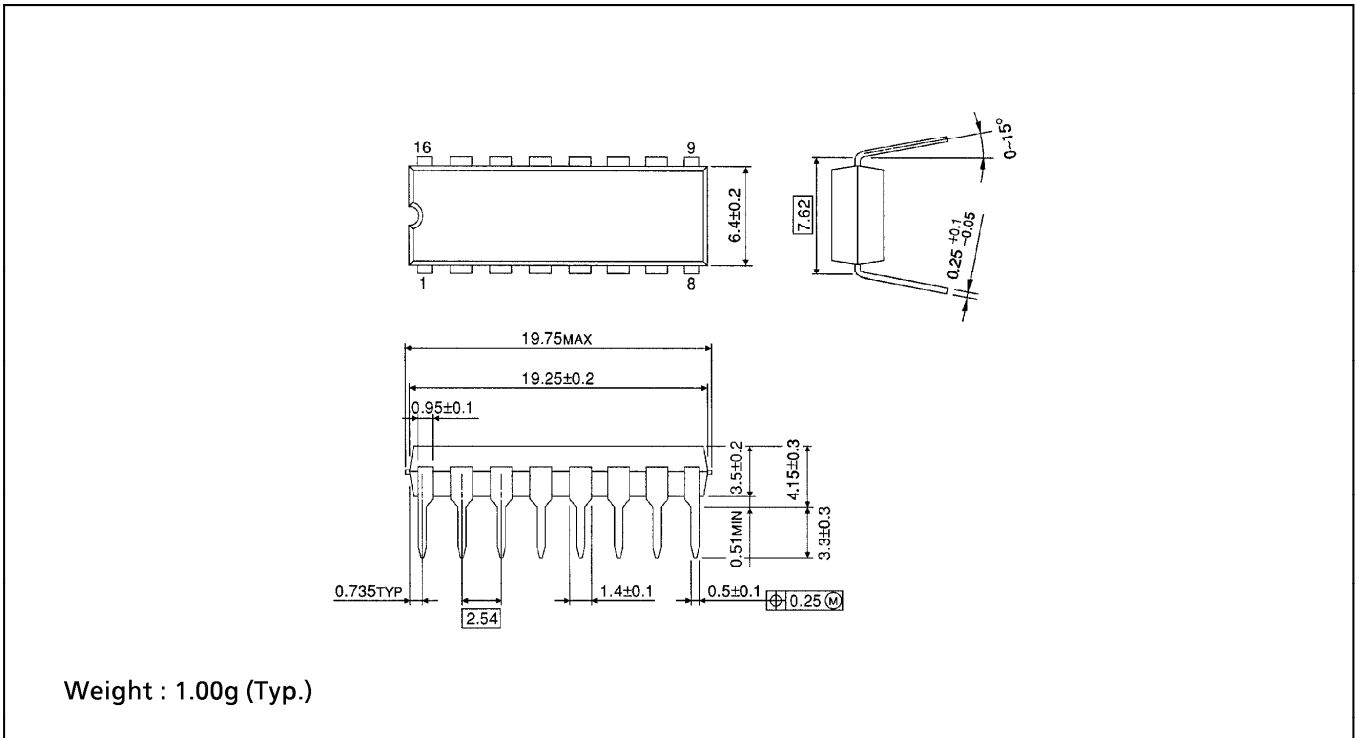

SOP 16PIN (200mil BODY) OUTLINE DRAWING (SOP16-P-300-1.27)

Unit in mm

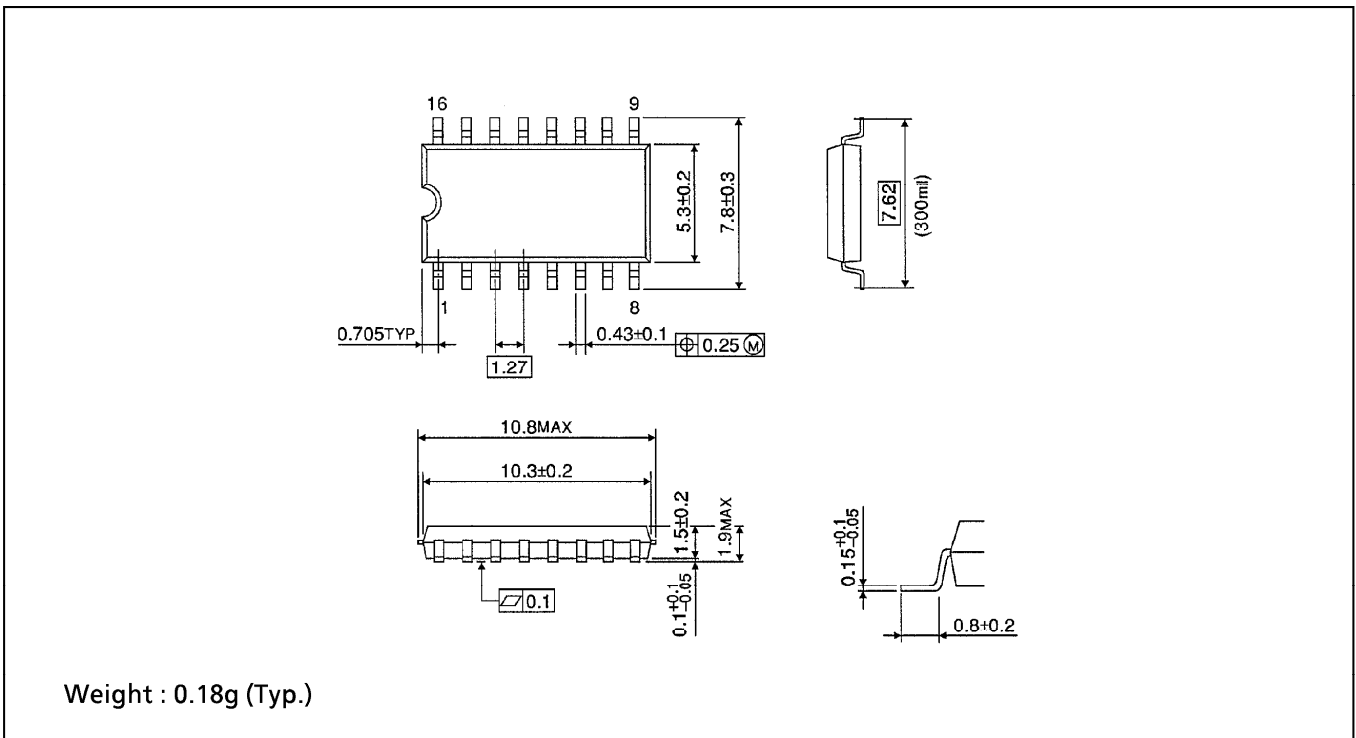

SOP 16PIN (150mil BODY) OUTLINE DRAWING (SOL16-P-150 -1.27)

Unit in mm

(Note) This package is not available in Japan.

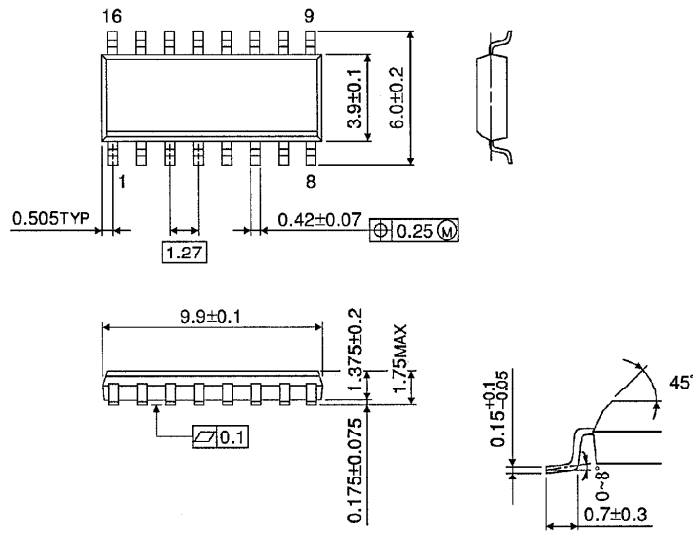

Weight : 0.13g (Typ.)