

Preliminary Technical Data
AD7476/AD7477
FEATURES

Fast Throughput Rate: 1MSPS
Specified for V_{DD} of 2.35 V to 5.25 V
Low Power:
 3.6mW typ at 1MSPS with 3V Supplies
 15mW typ at 1MSPS with 5V Supplies
Wide Input Bandwidth:
 70dB SNR at 200kHz Input Frequency
Flexible Power/Serial Clock Speed Management
No Pipeline Delays
High Speed Serial Interface
 SPI/QSPI/ μ Wire/DSP Compatible

Standby Mode: 1 μ A max
6-Lead SOT-23 Package

GENERAL DESCRIPTION

The AD7476/AD7477 are 12-bit and 10-bit, high speed, low power, successive-approximation ADCs respectively. The parts operate from a single 2.35 V to 5.25 V power supply and feature throughput rates up to 1MSPS. The parts contain a low-noise, wide bandwidth track/hold amplifier which can handle input frequencies in excess of 1MHz.

The conversion process and data acquisition are controlled using \overline{CS} and the serial clock, allowing the devices to interface with microprocessors or DSPs. The input signal is sampled on the falling edge of \overline{CS} and the conversion is also initiated at this point. There are no pipelined delays associated with the part.

The AD7476/AD7477 use advanced design techniques to achieve very low power dissipation at high throughput rates.

The reference for the part is taken internally from V_{DD} . The analog input range for the part is 0 to V_{DD} . The conversion rate is determined by the SCLK.

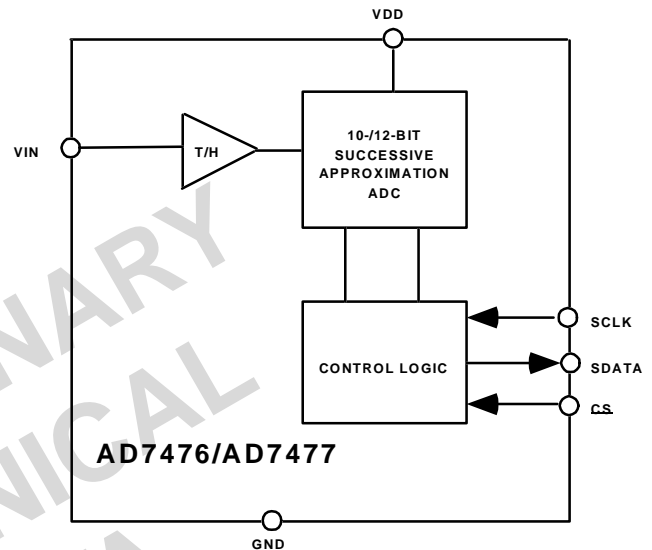
FUNCTIONAL BLOCK DIAGRAM

PRODUCT HIGHLIGHTS

1. First 10-/12-Bit ADCs in a SOT-23 package.
2. High Throughput with Low Power Consumption
3. Flexible Power/Serial Clock Speed Management
 The conversion rate is determined by the serial clock allowing the conversion time to be reduced through the serial clock speed increase. This allows the average power consumption to be reduced when a powerdown mode is used while not converting. The part also features a shutdown mode to maximize power efficiency at lower throughput rates. Power consumption is 1 μ A max when in shutdown.
4. No Pipeline Delay
 The part features a standard successive-approximation ADC with accurate control of the sampling instant via a \overline{CS} input and once off conversion control.

REV. PrF 08/99

Information furnished by Analog Devices is believed to be accurate and reliable. However, no responsibility is assumed by Analog Devices for its use, nor for any infringements of patents or other rights of third parties which may result from its use. No license is granted by implication or otherwise under any patent or patent rights of Analog Devices.

One Technology Way, P.O. Box 9106, Norwood, MA 02062-9106, U.S.A.
 Tel: 781/329-4700 World Wide Web Site: <http://www.analog.com>
 Fax: 781/326-8703 Analog Devices, Inc., 1998

AD7476–SPECIFICATIONS¹

($V_{DD} = +2.35\text{ V to }+5.25\text{ V}$, A Grade: $f_{SCLK} = 20\text{ MHz}$, $f_{SAMPLE} = 1\text{ Msps}$ unless otherwise noted; B Grade: $f_{SCLK} = 11\text{ MHz}$, $f_{SAMPLE} = 600\text{ Ksps}$ unless otherwise noted; $T_A = T_{MIN}$ to T_{MAX} , unless otherwise noted.)

Parameter	A Version ¹	B Version ¹	Units	Test Conditions/Comments
DYNAMIC PERFORMANCE				
				$F_{IN} = 200\text{ kHz}$ Sine Wave A Grade: $V_{DD} = (2.7\text{ V to }5.25\text{ V})^4$
Signal to Noise + Distortion (SINAD)	70	70	dB min	
Signal to Noise Ratio (SNR)	70	70	dB min	
Total Harmonic Distortion (THD)	-76	-76	dB max	
Peak Harmonic or Spurious Noise (SFDR)	-76	-76	dB max	
Intermodulation Distortion (IMD)				
Second Order Terms	-78	-78	dB typ	
Third Order Terms	-78	-78	dB typ	
Aperture Delay	10	10	ns max	
Aperture Jitter	10	10	ps typ	
Full Power Bandwidth	5	5	MHz typ	@ 3 dB
DC ACCURACY				
				B Grade, $V_{DD} = (2.35\text{ V to }3.6\text{ V})^5$.
Resolution	12	12	Bits	
Integral Nonlinearity		± 1.5	LSB max	
	± 1.5	± 1	LSB typ	
Differential Nonlinearity		± 0.9	LSB max	Guaranteed No Missed Codes to 12 Bits.
	± 0.9		LSB typ	
Offset Error		± 3	LSB max	
	± 3		LSB typ	
Gain Error		± 3	LSB max	
	± 3		LSB typ	
ANALOG INPUT				
Input Voltage Ranges	0 to V_{DD}	0 to V_{DD}	Volts	
DC Leakage Current	± 1	± 1	μA max	
Input Capacitance	20	20	pF typ	
LOGIC INPUTS				
Input High Voltage, V_{INH}	2.8	2.8	V min	$V_{DD} = 5\text{ V}$
	2.4	2.4	V min	$V_{DD} = 3\text{ V}$
Input Low Voltage, V_{INL}	0.4	0.4	V max	
Input Current, I_{IN}	± 1	± 1	μA max	Typically 10 nA, $V_{IN} = 0\text{ V}$ or V_{DD}
Input Capacitance, C_{IN}^2	10	10	pF max	
LOGIC OUTPUTS				
Output High Voltage, V_{OH}	$V_{DD} - 0.2$	$V_{DD} - 0.2$	V min	$I_{SOURCE} = 200\ \mu\text{A}$; $V_{DD} = 2.7\text{ V to }5.25\text{ V}$
Output Low Voltage, V_{OL}	0.4	0.4	V max	$I_{SINK} = 200\ \mu\text{A}$
Floating-State Leakage Current	± 10	± 10	μA max	
Floating-State Output Capacitance ²	10	10	pF max	
Output Coding	Straight (Natural) Binary			
CONVERSION RATE				
Conversion Time	0.8	1.45	μs max	16 SCLK cycles
Track/Hold Acquisition Time	400	400	ns max	
Throughput Rate	1000	600	KSPS max	Conversion Time + Quiet Time.

AD7476—SPECIFICATIONS¹

($V_{DD} = +2.35\text{ V to }+5.25\text{ V}$, A Grade: $f_{SCLK} = 20\text{MHz}$, $f_{SAMPLE} = 1\text{Msps}$ unless otherwise noted; B Grade: $f_{SCLK} = 11\text{MHz}$, $f_{SAMPLE} = 600\text{Ksps}$ unless otherwise noted; $T_A = T_{MIN}$ to T_{MAX} , unless otherwise noted.)

Parameter	A Version ¹	B Version ¹	Units	Test Conditions/Comments
POWER REQUIREMENTS				
V_{DD}	+2.35/+5.25	+2.35/+5.25	V min/max	Digital I/Ps = 0V or V_{DD} .
I_{DD} ⁴				$V_{DD} = 4.75\text{V to }5.25\text{V}$. SCLK on or off.
Normal Mode(Static)	2.1	2.1	mA typ	$V_{DD} = 2.35\text{V to }3.6\text{V}$. SCLK on or off.
Normal Mode (Operational)	1	1	mA typ	$V_{DD} = 4.75\text{V to }5.25\text{V}$. $F_{SAMPLE} = F_{SAMPLE}^{MAX6}$
	4	3	mA max	$V_{DD} = 2.35\text{V to }3.6\text{V}$. $F_{SAMPLE} = F_{SAMPLE}^{MAX6}$
	2	1.7	mA max	SCLK on or off.
Full Power-Down Mode	1	1	$\mu\text{A max}$	
Power Dissipation ³				
Normal Mode (Operational)	20	15	mW max	$V_{DD} = 5\text{V}$. $F_{SAMPLE} = F_{SAMPLE}^{MAX6}$
	6	5.1	mW max	$V_{DD} = 3\text{V}$. $F_{SAMPLE} = F_{SAMPLE}^{MAX6}$
Full Power-Down	5	5	$\mu\text{W max}$	$V_{DD} = 5\text{V}$.
	3	3	$\mu\text{W max}$	$V_{DD} = 3\text{V}$.

NOTES

¹Temperature ranges as follows: A, B Versions: $-40^{\circ}\text{C to }+85^{\circ}\text{C}$.

²Sample tested @ $+25^{\circ}\text{C}$ to ensure compliance.

³See POWER VERSUS THROUGHPUT RATE section.

⁴A Grade spec applies as a typical figure when $V_{DD} = 2.35\text{V}$.

⁵B Grade spec applies as a typical figure when $V_{DD} = 5.25\text{V}$.

⁶A Grade: $F_{SAMPLE}^{MAX} = 1\text{Msps}$; B Grade: $F_{SAMPLE}^{MAX} = 600\text{Ksps}$.

Specifications subject to change without notice.

PRELIMINARY
TECHNICAL
DATA

AD7477–SPECIFICATIONS¹ ($V_{DD} = +2.7\text{ V to }+5.25\text{ V}$, $f_{SCLK} = 20\text{MHz}$ unless otherwise noted; $T_A = T_{MIN}$ to T_{MAX} , unless otherwise noted.)

Parameter	AD7477 ¹	Units	Test Conditions/Comments
DYNAMIC PERFORMANCE			
Signal to Noise + Distortion (SINAD)	61	dB min	$F_{IN} = 200\text{kHz Sine Wave}$, $f_{SAMPLE} = 1\text{MSPs}$
Signal to Noise Ratio (SNR)	61	dB min	$F_{IN} = 200\text{kHz Sine Wave}$, $f_{SAMPLE} = 1\text{MSPs}$
Total Harmonic Distortion (THD)	-76	dB max	$F_{IN} = 200\text{kHz Sine Wave}$, $f_{SAMPLE} = 1\text{MSPs}$
Peak Harmonic or Spurious Noise (SFDR)	-76	dB max	$F_{IN} = 200\text{kHz Sine Wave}$, $f_{SAMPLE} = 1\text{MSPs}$
Intermodulation Distortion (IMD)			
Second Order Terms	-67	dB typ	
Third Order Terms	-67	dB typ	
Aperture Delay	10	ns max	
Aperture Jitter	10	ps typ	
Full Power Bandwidth	5	MHz typ	@ 3 dB
DC ACCURACY			
Resolution	10	Bits	
Integral Nonlinearity	± 1	LSB max	Guaranteed No Missed Codes to 10 Bits.
Differential Nonlinearity	± 0.9	LSB max	
Offset Error	± 1	LSB max	
Gain Error	± 1	LSB max	
ANALOG INPUT			
Input Voltage Ranges	0 to V_{DD}	Volts	
DC Leakage Current	± 1	$\mu\text{A max}$	
Input Capacitance	20	pF typ	
LOGIC INPUTS			
Input High Voltage, V_{INH}	2.8	V min	$V_{DD} = 5\text{V}$
	2.4	V min	$V_{DD} = 3\text{V}$
Input Low Voltage, V_{INL}	0.4	V max	
Input Current, I_{IN}	± 1	$\mu\text{A max}$	Typically 10 nA, $V_{IN} = 0\text{ V or }V_{DD}$
Input Capacitance, C_{IN}^2	10	pF max	
LOGIC OUTPUTS			
Output High Voltage, V_{OH}	$V_{DD} - 0.2$	V min	$I_{SOURCE} = 200\ \mu\text{A}$; $V_{DD} = 2.7\text{ V to }5.25\text{ V}$ $I_{SINK} = 200\ \mu\text{A}$
Output Low Voltage, V_{OL}	0.4	V max	
Floating-State Leakage Current	± 10	$\mu\text{A max}$	
Floating-State Output Capacitance ²	10	pF max	
Output Coding	Straight (Natural) Binary		
CONVERSION RATE			
Conversion Time	800	ns max	16 SCLK cycles with SCLK at 20MHz
Track/Hold Acquisition Time	400	ns max	
Throughput Rate	1	MSPS max	Conversion Time + Quiet Time.
POWER REQUIREMENTS			
V_{DD}	+2.7/+5.25	V min/max	Digital I/Ps = 0V or V_{DD} . $V_{DD} = 4.75\text{V to }5.25\text{V}$. SCLK on or off. $V_{DD} = 2.7\text{V to }3.6\text{V}$. SCLK on or off. $V_{DD} = 4.75\text{V to }5.25\text{V}$. $F_{SAMPLE} = 1\text{MSPS}$ $V_{DD} = 2.7\text{V to }3.6\text{V}$. $F_{SAMPLE} = 1\text{MSPS}$ SCLK on or off. $V_{DD} = 5\text{V}$. $F_{SAMPLE} = 1\text{MSPS}$ $V_{DD} = 3\text{V}$. $F_{SAMPLE} = 1\text{MSPS}$ $V_{DD} = 5\text{V}$.
I_{DD}^4			
Normal Mode(Static)	2.1	mA typ	
	1	mA typ	
Normal Mode (Operational)	4	mA max	
	2	mA max	
Full Power-Down Mode	1	$\mu\text{A max}$	
Power Dissipation ³			
Normal Mode (Operational)	20	mW max	
	6	mW max	
Full Power-Down	5	$\mu\text{W max}$	

NOTES

¹Temperature ranges as follows: A, B Versions: $-40^\circ\text{C to }+85^\circ\text{C}$.

²Sample tested @ $+25^\circ\text{C}$ to ensure compliance.

³See POWER VERSUS THROUGHPUT RATE section.

Specifications subject to change without notice.

TIMING SPECIFICATIONS¹ ($V_{DD} = +2.35\text{ V to }+5.25\text{ V}$; $T_A = T_{MIN}\text{ to }T_{MAX}$, unless otherwise noted.)

Parameter	Limit at T_{MIN} , T_{MAX} AD7476/AD7477		Units	Description
	A Version	B Version		
f_{SCLK}^2	10 20	10 11	kHz min MHz max	
$t_{CONVERT}$	$16^* t_{SCLK}$	$16^* t_{SCLK}$	ns max	$t_{SCLK} = 1/f_{SCLK}$ $f_{SCLK} = \text{MHz}$
t_{quiet}	100	100	ns min	Minimum Quiet Time required between conversions
t_2	10	10	ns min	CS to SCLK Setup Time
t_3^3	tbd	tbd	ns max	Delay from \overline{CS} Until SDATA 3-State Disabled
t_4^3	10	10	ns max	Data Access Time After SCLK Falling Edge
t_5	tbd	tbd	ns min	Data Setup Time prior to SCLK Falling Edge
t_6	$0.4t_{SCLK}$	$0.4t_{SCLK}$	ns min	SCLK High Pulse Width
t_7	$0.4t_{SCLK}$	$0.4t_{SCLK}$	ns min	SCLK Low Pulse Width
t_8	5	5	ns min	SCLK to Data Valid Hold Time
t_9^4	25	25	ns max	SCLK falling Edge to SDATA High Impedance
t_{10}	1	1	$\mu\text{s typ}$	Power up time from Full Power-down

NOTES

¹Sample tested at +25°C to ensure compliance. All input signals are specified with $t_r = t_f = 5\text{ ns}$ (10% to 90% of V_{DD}) and timed from a voltage level of 1.6 Volts. See Figure 2.

²Mark/Space ratio for the SCLK input is 40/60 to 60/40.

³Measured with the load circuit of Figure 1 and defined as the time required for the output to cross 0.8 V or 2.0 V.

⁴ t_9 is derived from the measured time taken by the data outputs to change 0.5 V when loaded by the circuit of Figure 1. The measured number is then extrapolated back to remove the effects of charging or discharging the 50 pF capacitor. This means that the time, t_9 , quoted in the timing characteristics is the true bus relinquish time of the part and is independent of the bus loading.

Specifications subject to change without notice.

ABSOLUTE MAXIMUM RATINGS¹

($T_A = +25^\circ\text{C}$ unless otherwise noted)

V_{DD} to GND	-0.3 V to 7 V
Analog Input Voltage to GND	-0.3 V to $V_{DD} + 0.3\text{ V}$
Digital Input Voltage to GND	-0.3 V to 7 V
Digital Output Voltage to GND	-0.3 V to $V_{DD} + 0.3\text{ V}$
Input Current to Any Pin Except Supplies ²	$\pm 10\text{ mA}$
Operating Temperature Range	
Commercial (A, B Version)	-40°C to +85°C
Storage Temperature Range	-65°C to +150°C
Junction Temperature	+150°C
SOT-23 Package, Power Dissipation	450 mW
θ_{JA} Thermal Impedance	229.6°C/W (SOT23)
θ_{JC} Thermal Impedance	91.99°C/W (SOT23)

Lead Temperature, Soldering

Vapor Phase (60 secs)

+215°C

Infrared (15 secs)

+220°C

NOTES

¹Stresses above those listed under "Absolute Maximum Ratings" may cause permanent damage to the device. This is a stress rating only and functional operation of the device at these or any other conditions above those listed in the operational sections of this specification is not implied. Exposure to absolute maximum rating conditions for extended periods may affect device reliability.

²Transient currents of up to 100 mA will not cause SCR latch up.

ORDERING GUIDE

Model	Range	Linearity Error (LSB) ¹	Package Option ²	Branding
AD7476ART	40°C to +85°C	$\pm 1.5\text{ typ}$	RT-6	CEA
AD7476BRT	40°C to +85°C	$\pm 1.5\text{ max}$	RT-6	CEB
AD7477ART	40°C to +85°C	$\pm 1\text{ max}$	RT-6	CFA

NOTES

²RT = SOT-23.

CAUTION

ESD (electrostatic discharge) sensitive device. Electrostatic charges as high as 4000 V readily accumulate on the human body and test equipment and can discharge without detection. Although the AD7476/AD7477 feature proprietary ESD protection circuitry, permanent damage may occur on devices subjected to high energy electrostatic discharges. Therefore, proper ESD precautions are recommended to avoid performance degradation or loss of functionality.

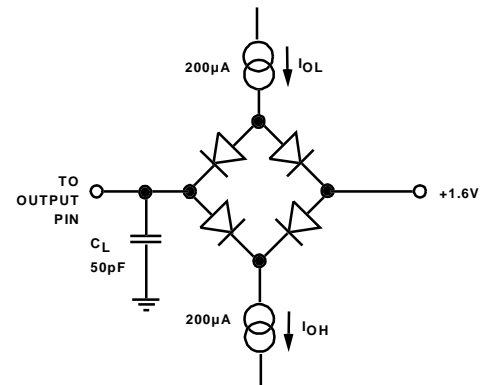

Figure 1. Load Circuit for Digital Output Timing Specifications



PIN FUNCTION DESCRIPTION

Pin No.	Pin Mnemonic	Function
6	\overline{CS}	Chip Select. Active low logic input. This input provides the dual function of initiating conversions on the AD7476/AD7477 and also frames the serial data transfer.
1	V_{DD}	Power Supply Input. The V_{DD} range for the AD7476/AD7477 is from +2.35V to +5.25V.
2	GND	Analog Ground. Ground reference point for all circuitry on the AD7476/AD7477. All analog input signals and any external reference signal should be referred to this GND voltage.
3	VIN	Analog Input. Single-ended analog input channel. The input range is 0 to V_{DD} .
5	SDATA	Data Out. Logic Output. The conversion result from the AD7476/AD7477 is provided on this output as a serial data stream. The bits are clocked out on the falling edge of the SCLK input. The data stream consists of four leading zeros followed by the 12 bits of conversion data which is provided MSB first.
4	SCLK	Serial Clock. Logic input. SCLK provides the serial clock for accessing data from the part. This clock input is also used as the clock source for the AD7476/AD7477's conversion process.

PRELIMINARY
TECHNICAL
DATA

AD7476/AD7477 PINCONFIGURATION SOT-23

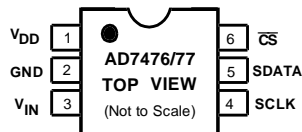

TERMINOLOGY**Integral Nonlinearity**

This is the maximum deviation from a straight line passing through the endpoints of the ADC transfer function. The endpoints of the transfer function are zero scale, a point 1/2 LSB below the first code transition, and full scale, a point 1/2 LSB above the last code transition.

Differential Nonlinearity

This is the difference between the measured and the ideal 1 LSB change between any two adjacent codes in the ADC.

Offset Error

This is the deviation of the first code transition (00 . . . 000) to (00 . . . 001) from the ideal, i.e. AGND + 1LSB

Gain Error

This is the deviation of the last code transition (111 . . . 110) to (111 . . . 111) from the ideal (i.e., $V_{REF} - 1$ LSB) after the offset error has been adjusted out.

Track/Hold Acquisition Time

The track/hold amplifier returns into track mode and the end of conversion. Track/Hold acquisition time is the time required for the output of the track/hold amplifier to reach its final value, within ± 0.5 LSB, after the end of conversion.

Signal to (Noise + Distortion) Ratio

This is the measured ratio of signal to (noise + distortion) at the output of the A/D converter. The signal is the rms amplitude of the fundamental. Noise is the sum of all nonfundamental signals up to half the sampling frequency ($f_s/2$), excluding dc. The ratio is dependent on the number of quantization levels in the digitization process; the more levels, the smaller the quantization noise. The theoretical signal to (noise + distortion) ratio for an ideal N-bit converter with a sine wave input is given by:

$$\text{Signal to (Noise + Distortion)} = (6.02 N + 1.76) \text{ dB}$$

Thus for a 12-bit converter, this is 74 dB and for a 10-bit converter this is 62dB.

Total Harmonic Distortion

Total harmonic distortion (THD) is the ratio of the rms sum of harmonics to the fundamental. For the AD7476/AD7477, it is defined as:

$$\text{THD (dB)} = 20 \log \frac{\sqrt{V_2^2 + V_3^2 + V_4^2 + V_5^2 + V_6^2}}{V_1}$$

where V_1 is the rms amplitude of the fundamental and V_2 , V_3 , V_4 , V_5 and V_6 are the rms amplitudes of the second through the sixth harmonics.

Peak Harmonic or Spurious Noise

Peak harmonic or spurious noise is defined as the ratio of the rms value of the next largest component in the ADC output spectrum (up to $f_s/2$ and excluding dc) to the rms value of the fundamental. Normally, the value of this specification is determined by the largest harmonic in the spectrum, but for ADCs where the harmonics are buried in the noise floor, it will be a noise peak.

Intermodulation Distortion

With inputs consisting of sine waves at two frequencies, f_a and f_b , any active device with nonlinearities will create distortion products at sum and difference frequencies of $m f_a \pm n f_b$ where $m, n = 0, 1, 2, 3$, etc. Intermodulation distortion terms are those for which neither m nor n are equal to zero. For example, the second order terms include $(f_a + f_b)$ and $(f_a - f_b)$, while the third order terms include $(2f_a + f_b)$, $(2f_a - f_b)$, $(f_a + 2f_b)$ and $(f_a - 2f_b)$.

The AD7476/AD7477 are tested using the CCIF standard where two input frequencies near the top end of the input bandwidth are used. In this case, the second order terms are usually distanced in frequency from the original sine waves while the third order terms are usually at a frequency close to the input frequencies. As a result, the second and third order terms are specified separately. The calculation of the intermodulation distortion is as per the THD specification where it is the ratio of the rms sum of the individual distortion products to the rms amplitude of the sum of the fundamentals expressed in dBs.

MODES OF OPERATION

The mode of operation of the AD7476/AD7477 is selected by controlling the (logic) state of the \overline{CS} signal during a conversion. There are two possible modes of operation, Normal Mode and Power-Down Mode. The point at which \overline{CS} is pulled high after the conversion has been initiated will determine whether the AD7476/AD7477 will enter Power-down Mode or not. Similarly, if already in Power-down then \overline{CS} can control whether the device will return to Normal operation or remain in Power-down. These modes of operation are designed to provide flexible power management options. These options can be chosen to optimize the power dissipation/throughput rate ratio for differing application requirements.

Normal Mode

This mode is intended for fastest throughput rate performance as the user does not have to worry about any power-up times with the AD7476/AD7477 remaining

fully-powered all the time. Figure 2 shows the general diagram of the operation of the AD7476/AD7477 in this mode.

The conversion is initiated on the falling edge of \overline{CS} as described in the Serial Interface section. To ensure the part remains fully powered up at all times \overline{CS} must remain low until at least 10 SCLK falling edges have elapsed after the falling edge of \overline{CS} . If \overline{CS} is brought high any time after the 10th SCLK falling edge but before the 16th SCLK falling edge the part will remain powered up but the conversion will be terminated and SDATA will go back into tri-state. Sixteen serial clock cycles are required to complete the conversion and access the complete conversion result. \overline{CS} may idle high until the next conversion or may idle low until sometime prior to the next conversion, (effectively idling \overline{CS} low).

Once a data transfer is complete (SDATA has returned to tri-state), another conversion can be initiated after the quiet time, t_{quiet} , has elapsed by bringing \overline{CS} low again.

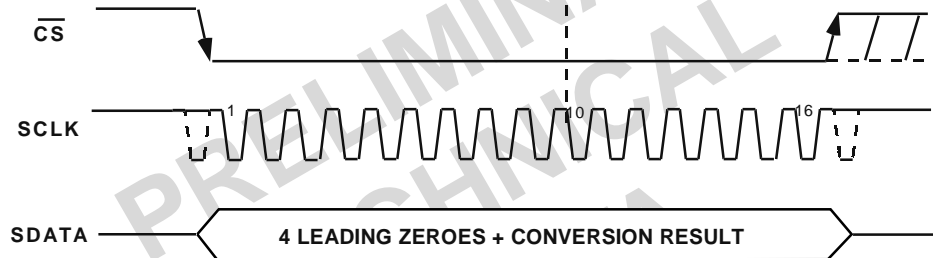

Figure 2. Normal Mode Operation

Power-Down Mode

This mode is intended for use in applications where slower throughput rates are required; either the ADC is powered down between each conversion, or a series of conversions may be performed at a high throughput rate and then the ADC is powered down for a relatively long duration between these bursts of several conversions. When the AD7476/AD7477 is in power down, all analog circuitry is powered down.

To enter Power-Down, the conversion process must be interrupted by bringing \overline{CS} high anywhere after the second falling edge of SCLK and before the tenth falling edge of SCLK as shown in Figure 3. Once \overline{CS} has been brought high in this window of SCLKs, then the part will enter power down and the conversion that was initiated by the falling edge of \overline{CS} will be terminated and SDATA will go back into tri-state. If \overline{CS} is brought high before the second SCLK falling edge, then the part will remain in Normal

Mode and will not power-down. This will avoid accidental powerdown due to glitches on the \overline{CS} line.

In order to exit this mode of operation and power the AD7476/AD7477 up again, a dummy conversion is performed. On the falling edge of \overline{CS} the device will begin to power up, and will continue to power up as long as \overline{CS} is held low until after the falling edge of the tenth SCLK. The device will be fully powered up once 16 SCLKs have elapsed and valid data will result from the next conversion as shown in figure 4. If \overline{CS} is brought high before the tenth falling edge of SCLK, then the AD7476/AD7477 will go back into power down again. This avoids accidental power up due to glitches on the \overline{CS} line or an inadvertent burst of 8 SCLK cycles while \overline{CS} low. So although the device may begin to power up on the falling edge of \overline{CS} , it will power down again on the rising edge of \overline{CS} as long as it occurs before the tenth SCLK falling edge.

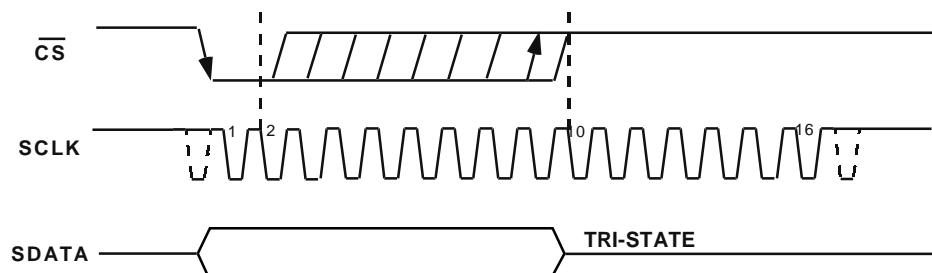

Figure 3. Entering Power Down Mode

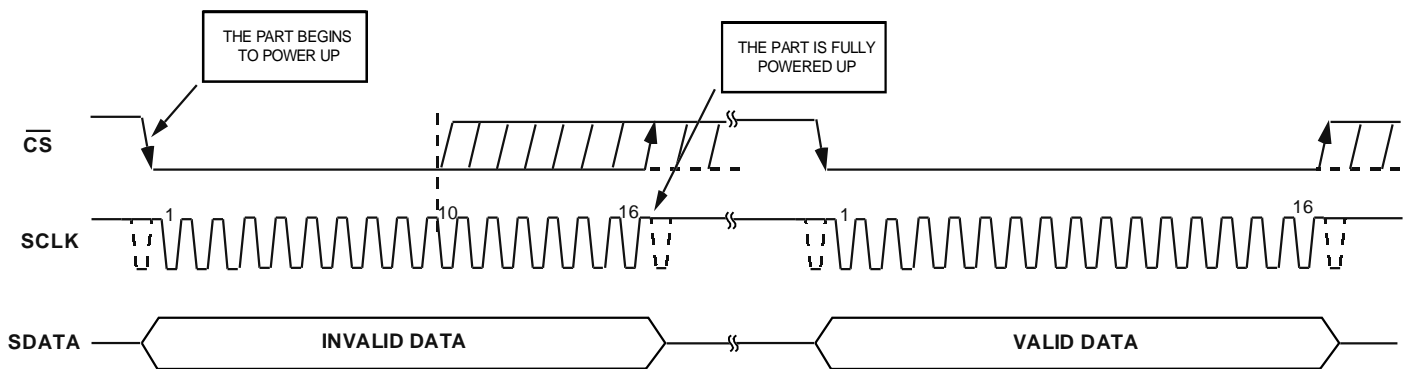

Figure 4. Exiting Power Down Mode

SERIAL INTERFACE

Figure 5 and Figure 6 show the detailed timing diagram for serial interfacing to the AD7476 and the AD7477 respectively. The serial clock provides the conversion clock and also controls the transfer of information from the AD7476/AD7477 during conversion.

\overline{CS} initiates the data transfer and conversion process. The falling edge of \overline{CS} puts the track and hold into hold mode, takes the bus out of tristate and the analog input is sampled at this point. The conversion is also initiated at this point and will require 16 SCLK cycles to complete. Once 13 SCLK falling edges have elapsed, then the track and hold will go back into track on the next SCLK rising edge. On the 16th SCLK falling edge the SDATA line will go back into tristate. If the rising edge of \overline{CS} occurs before 16 SCLKs have elapsed then the conversion will be terminated and the SDATA line will go back into tri-state, otherwise SDATA returns to tri-state on the 16th SCLK falling edge as shown in Figure 5 and Figure 6.

Sixteen serial clock cycles are required to perform the conversion process and to access data from the AD7476/AD7477. \overline{CS} going low provides the first leading zero to be read in by the microcontroller or DSP. The remaining data is then clocked out by subsequent SCLK falling edges beginning with the 2nd leading zero, thus the first falling clock edge on the serial clock has the second leading zero provided. The final bit in the data transfer is valid on the sixteenth falling edge, having been clocked out on the previous (15th) falling edge. In applications with a slower SCLK, it may be possible to read in data on each SCLK rising edge, i.e. the first rising edge of SCLK after the \overline{CS} falling edge would provide the first leading zero and the 15th rising SCLK edge would provide DB0.

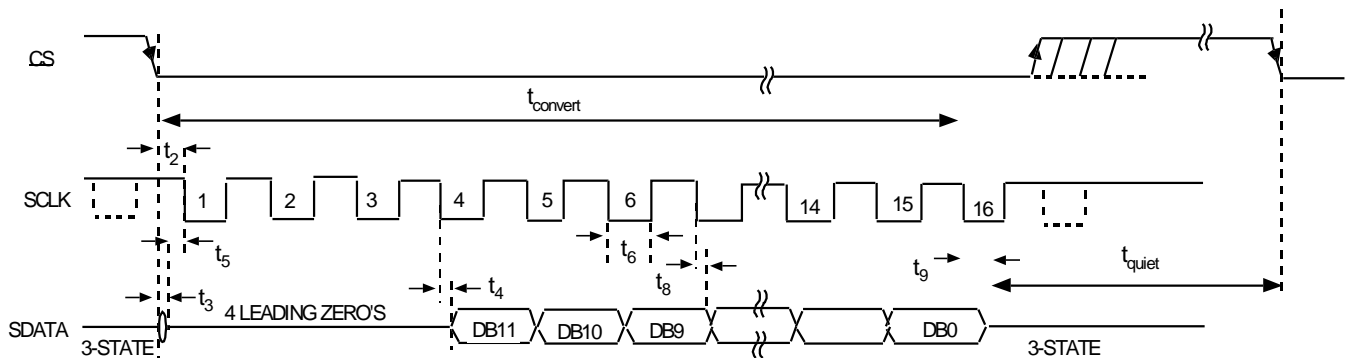

Figure 5. AD7476 Serial Interface Timing Diagram

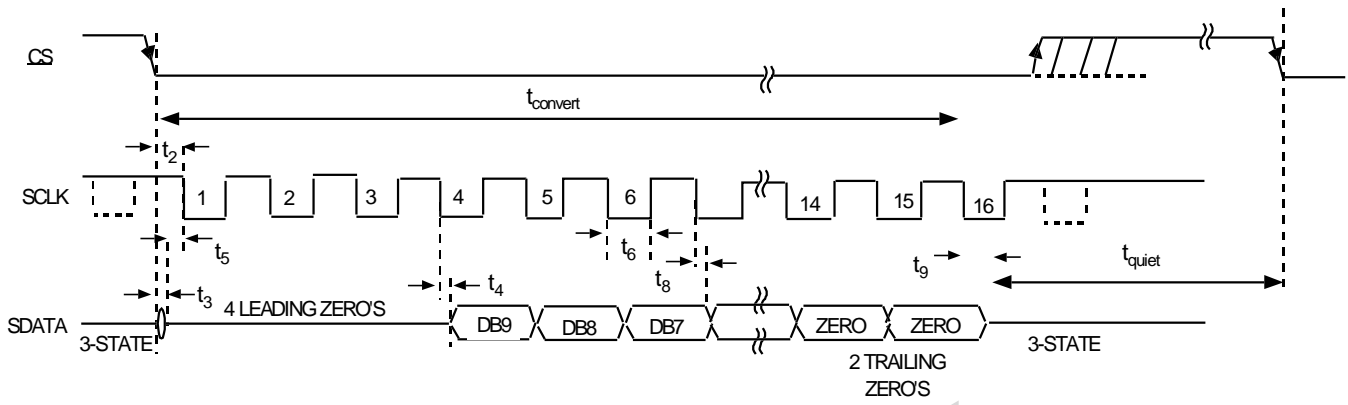
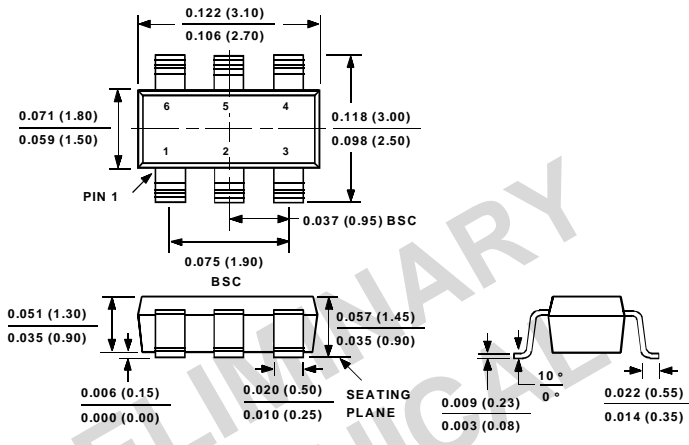

Figure 6. AD7477 Serial Interface Timing Diagram

PRELIMINARY
TECHNICAL
DATA

OUTLINE DIMENSIONS
 Dimensions shown in inches and (mm).

6-lead SOT23 (RT-6)



PRELIMINARY
 TECHNICAL
 DATA