

# DIESEL ENGINE-GENERATOR SET

## 550-VC6DT2

550 ekW / 60 Hz / Standby  
500 ekW / 60 Hz / Prime  
208 - 4160V



### SYSTEM RATINGS

#### Standby

| Voltage (L-L)    | 208V**          | 240V**           | 480V**         | 600V**     | 4160V      |
|------------------|-----------------|------------------|----------------|------------|------------|
| Phase            | 3               | 3                | 3              | 3          | 3          |
| PF               | 0.8             | 0.8              | 0.8            | 0.8        | 0.8        |
| Hz               | 60              | 60               | 60             | 60         | 60         |
| kW               | 550             | 550              | 550            | 550        | 550        |
| kVA              | 687.5           | 687.5            | 687.5          | 687.5      | 687.5      |
| AMPS             | 1908            | 1654             | 827            | 662        | 95         |
| skVA@30%         |                 |                  |                |            |            |
| Voltage Dip      | 1450            | 1450             | 1500           | 1450       | 1550       |
| Generator Model* | 572RSL4031      | 572RSL4031       | 572RSL4029     | 572RSS4272 | 574FSM4356 |
| Temp Rise        | 130°C/27°C      | 130°C/27°C       | 130°C/27°C     | 125°C/40°C | 130°C/27°C |
| Connection       | 12 LEAD LOW WYE | 12 LEAD HI DELTA | 12 LEAD HI WYE | 4 LEAD WYE | 6 LEAD WYE |

#### Prime

| Voltage (L-L)    | 208V            | 240V             | 480V           | 600V       | 4160V      |
|------------------|-----------------|------------------|----------------|------------|------------|
| Phase            | 3               | 3                | 3              | 3          | 3          |
| PF               | 0.8             | 0.8              | 0.8            | 0.8        | 0.8        |
| Hz               | 60              | 60               | 60             | 60         | 60         |
| kW               | 500             | 500              | 500            | 500        | 500        |
| kVA              | 625             | 625              | 625            | 625        | 625        |
| AMPS             | 1735            | 1504             | 752            | 601        | 87         |
| skVA@30%         |                 |                  |                |            |            |
| Voltage Dip      | 1450            | 1450             | 1500           | 1450       | 1550       |
| Generator Model* | 572RSL4031      | 572RSL4031       | 572RSL4029     | 572RSS4272 | 573FSM4356 |
| Temp Rise        | 105°C/40°C      | 105°C/40°C       | 105°C/40°C     | 105°C/40°C | 105°C/40°C |
| Connection       | 12 LEAD LOW WYE | 12 LEAD HI DELTA | 12 LEAD HI WYE | 4 LEAD WYE | 6 LEAD WYE |

\* The Generator Model Number identified in the table is for standard C Series Configuration. Consult the factory for alternate configuration.

\*\* UL2200 Offered

## FACTS

- // EPA Tier 2 Certified
- // Engine-Generator Set Tested to ISO 8528-5 for Transient Response
- // UL2200, CSA Listing Offered
- // Accepts Rated Load in One Step Per NFPA 110, Level 1
- // All engine-generator sets are prototype and factory tested
- // MTU Onsite Energy is a single source supplier
- // Global Product Support
- // 2 Year Standard Warranty
- // Custom Design for Any Application
- // TAD1642GE Diesel Engine
  - 16.1 Liter Displacement
  - Electronic Unit Pump Injection
  - 4-Cycle
- // Complete Range of Accessories
- // Permanent Magnet Generator (PMG)
  - Brushless, Rotating Field
  - 300% Short Circuit Capability
  - 2/3 Pitch Windings
- // Digital Control Panel(s)
  - UL Recognized, c  us, NFPA 110
  - Complete System Metering
  - LCD Display
- // Cooling System
  - Integral Set-Mounted
  - Engine Driven Fan

## STANDARD EQUIPMENT

### // Engine

.....  
Air Cleaner

.....  
Oil Pump

.....  
Full Flow Oil Filter

.....  
Jacket Water Pump

.....  
Thermostat

.....  
Exhaust Manifold - Dry

.....  
Blower Fan & Fan Drive

.....  
Radiator - Unit Mounted

.....  
Electric Starting Motor - 24V

.....  
Governor - Electric Isochronous

.....  
Base - Structural Steel

.....  
SAE Flywheel & Bell Housing

.....  
Charging Alternator - 24V

.....  
Battery Box & Cables

.....  
Flexible Fuel Connectors

.....  
Flexible Exhaust Connection

.....  
EPA Certified Engine

### // Generator

.....  
NEMA MG1, IEEE and ANSI standards compliance for temperature rise and motor starting

.....  
Sustained short circuit current of up to 300% of the rated current for up to 10 seconds

.....  
Self-Ventilated and Drip-Proof

.....  
Superior Voltage Waveform

.....  
Digital, Solid State, Volts-per-Hertz Regulator

.....  
No Load to Full Load Regulation

.....  
Brushless Alternator with Brushless Pilot Exciter

.....  
4 Pole, Rotating Field

.....  
130°C Standby Temperature Rise

.....  
1 Bearing, Sealed

.....  
Flexible Coupling

.....  
Full Amortisseur Windings

.....  
125% Rotor Balancing

.....  
3-Phase Voltage Sensing

.....  
±.25% Voltage Regulation

.....  
100% of Rated Load - One Step

.....  
3% Maximum Harmonic Content

### // Digital Control Panel(s)

.....  
Digital Metering

.....  
Engine Parameters

.....  
Generator Protection Functions

.....  
Engine Protection

.....  
SAE J1939 Engine ECU Communications

.....  
Windows-Based Software

.....  
Multilingual Capability

.....  
Remote Communications to our RDP-110 Remote Annunciator

.....  
16 Programmable Contact Inputs

.....  
7 Contact Outputs

.....  
UL Recognized, c  us, CE Approved

.....  
Event Recording

.....  
IP 54 Front Panel Rating with Integrated Gasket

.....  
NFPA110 Level Compatible

## APPLICATION DATA

### // Engine

|                               |             |
|-------------------------------|-------------|
| Manufacturer                  | Volvo Penta |
| Model                         | TAD1642GE   |
| Type                          | 4-Cycle     |
| Arrangement                   | 6-Inline    |
| Displacement: Cu In (lit)     | 984 (16.1)  |
| Bore: in (cm)                 | 5.67 (14.4) |
| Stroke: in (cm)               | 6.5 (16.5)  |
| Compression Ratio             | 16.5:1      |
| Rated RPM                     | 1,800       |
| Engine Governor               | EMS 2       |
| Max Power: Standby: bhp (kWm) | 821 (612)   |
| Max Power: Prime: bhp (kWm)   | 749 (559)   |
| Regulation                    | ± 25%       |
| Frequency                     | 60 Hz       |
| Air Cleaner                   | Dry         |

### // Liquid Capacity (Lubrication)

|   |           |
|---|-----------|
| Total Oil System: gal (lit)             | 12.7 (48) |
| Engine Jacket Water Capacity: gal (lit) | 8.7 (33)  |
| System Coolant Capacity: gal (lit)      | 15.9 (60) |

### // Electrical

|  |       |
|--|-------|
| Electric Volts DC                      | 24    |
| Cold Cranking Amps Under 0°F (-17.8°C) | 1,155 |

### // Fuel System

|                                  |           |
|----------------------------------|-----------|
| Fuel Supply Connection Size      | 3/4" NPT  |
| Fuel Return Connection Size      | 1/2" NPT  |
| Maximum Fuel Lift: ft (m)        | 3.5 (1)   |
| Recommended Fuel                 | Diesel #2 |
| Total Fuel Flow: gal/hr (lit/hr) | 53 (200)  |

### // Fuel Consumption

|  | STANDBY    | PRIME      |
|--|------------|------------|
| At 100% of Power Rating: gal/hr (lit/hr) | 40.2 (152) | 36.2 (137) |
| At 75% of Power Rating: gal/hr (lit/hr)  | 29 (110)   | 26.3 (100) |
| At 50% of Power Rating: gal/hr (lit/hr)  | 19.3 (73)  | 17.6 (67)  |

### // Cooling - Radiator System

|   | STANDBY      | PRIME        |
|---|--------------|--------------|
| Ambient Capacity of Radiator: °F (°C)   | 122 (50)     | 122 (50)     |
| Max. Restriction of Cooling Air, Intake, and Discharge Side of Rad.: in. H <sub>2</sub> O (kPa) | 1.9 (0.49)   | 1.3 (0.32)   |
| Water Pump Capacity: gpm (lit/min)  | 122 (462)    | 122 (462)    |
| Heat Rejection to Coolant: BTUM (kW)  | 14,104 (248) | 12,397 (218) |
| Heat Radiated to Ambient: BTUM (kW)   | 3,653 (64)   | 2,992 (52.6) |

### // Air Requirements

|  | STANDBY      | PRIME        |
|--|--------------|--------------|
| Aspirating: *SCFM (m <sup>3</sup> /min)  | 1,646 (46.6) | 1,603 (45.4) |
| Air Flow Required for Rad. Cooled Unit: *SCFM (m <sup>3</sup> /min)                              | 19,116 (541) | 19,116 (541) |
| Air Flow Required for Heat Exchanger/Remote Rad. based on 25°F Rise: *SCFM (m <sup>3</sup> /min) | 8,239 (235)  | 6,748 (192)  |

\* Air density = 0.0739 lbm/ft<sup>3</sup> (1.184 kg/m<sup>3</sup>)

### // Exhaust System

|   | STANDBY       | PRIME         |
|---|---------------|---------------|
| Gas Temp. (Stack): °F (°C)                                  | 954 (512)     | 874 (468)     |
| Gas Volume at Stack Temp: CFM (m <sup>3</sup> /min)         | 4,153 (117.6) | 3,846 (108.9) |
| Maximum Allowable Back Pressure: in. H <sub>2</sub> O (kPa) | 40.2 (10)     | 40.2 (10)     |

## WEIGHTS AND DIMENSIONS

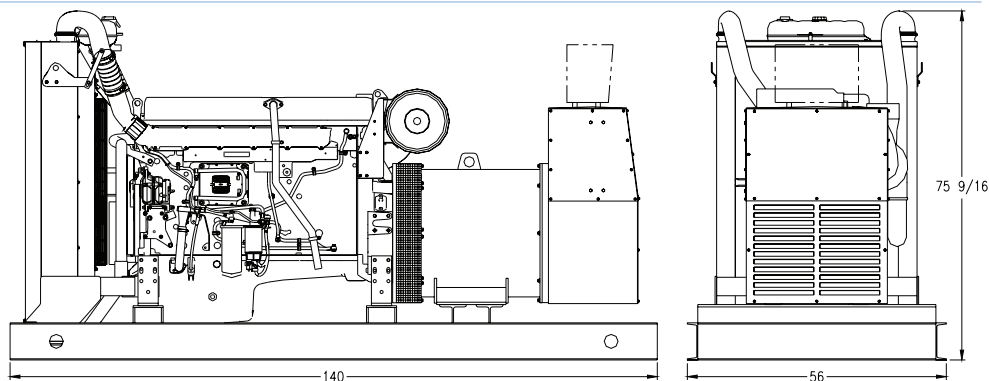

Drawing above for illustration purposes only, based on standard open power 480 volt generator. Lengths may vary with other voltages. Do not use for installation design.

| System | Dimensions (L x W x H)                        | Weight (less tank)  |
|--------|---|---------------------|
| OPU    | 140 x 56 x 75.6 in (3,560 x 1,420 x 1,920 mm) | 8,118 lb (3,682 kg) |

Weights and dimensions are based on open power units and are estimates only. Consult the factory for accurate weights and dimensions for your specific generator set.

## SOUND DATA

| Unit Type                          | Standby Full Load | Standby No Load | Prime Full Load | Prime No Load |
|------------------------------------|-------------------|-----------------|-----------------|---------------|
| OPU w/Critical Grade Muffler (dBA) | 98.5              | 90              | 97              | 90            |
| Sound Attenuated Enclosure (dBA)   | 90.5              | 82              | 89              | 82            |

Measurements for sound data are taken at 23 ft (7 m).

## EMISSIONS DATA

| NO <sub>x</sub> + NMHC | CO   | PM    |
|------------------------|------|-------|
| 4.02                   | 0.55 | 0.073 |

### All units are in g/hp-hr and are EPA D2 cycle values.

Emission levels of the engine may vary as a function of ambient temperature, barometric pressure, humidity, fuel type and quality, installation parameters, measuring instrumentation, etc. The data provided are laboratory results from one engine representing this rating. The data was obtained under controlled environmental conditions with calibrated instrumentation traceable to the United States National Bureau of Standards and in compliance with US EPA regulations found within 40 CFR Part 89. The weighted cycle value from each engine is guaranteed to be below the US EPA Standards at the US EPA defined conditions.

## RATING DEFINITIONS AND CONDITIONS

- // Ambient capability factor at 984 ft (300 m). Consult your local MTU Onsite Energy Power Generation Distributor for other altitudes.
- // Standby ratings apply to installations served by a reliable utility source. The standby rating is applicable to varying loads for the duration of a power outage. No overload capability for this rating. Ratings are in accordance with ISO-3046/1, BS 5514, AS 2789, and DIN 6271.
- // Prime power ratings apply to installations where utility power is unavailable or unreliable. At varying load, the number of generator set operating hours is unlimited. A 10% overload capacity is available for one hour in twelve. Ratings are in accordance with ISO-8528/1, overload power in accordance with ISO-3046/1, BS 5514, AS 2789, and DIN 6271. For limited running time and base load ratings, consult the factory.
- // Deration Factor:
  - Altitude:** 5% per 3,281 ft (1,000 m) above 3,707 ft (1,130 m).
  - Temperature:** No derate due to increased temperature.

Materials and specifications subject to change without notice.