

Am79574

Subscriber Line Interface Circuit



DISTINCTIVE CHARACTERISTICS

- Programmable constant resistance feed
- Line-feed characteristics independent of battery variations
- Programmable loop-detect threshold
- On-chip switching regulator for low-power dissipation
- Pin for external ground-key noise filter capacitor available
- Ground-key detect option available
- Two-wire impedance set by single external impedance
- Polarity reversal feature
- Tip Open state for ground-start lines
- Test relay driver optional
- On-hook transmission

BLOCK DIAGRAM

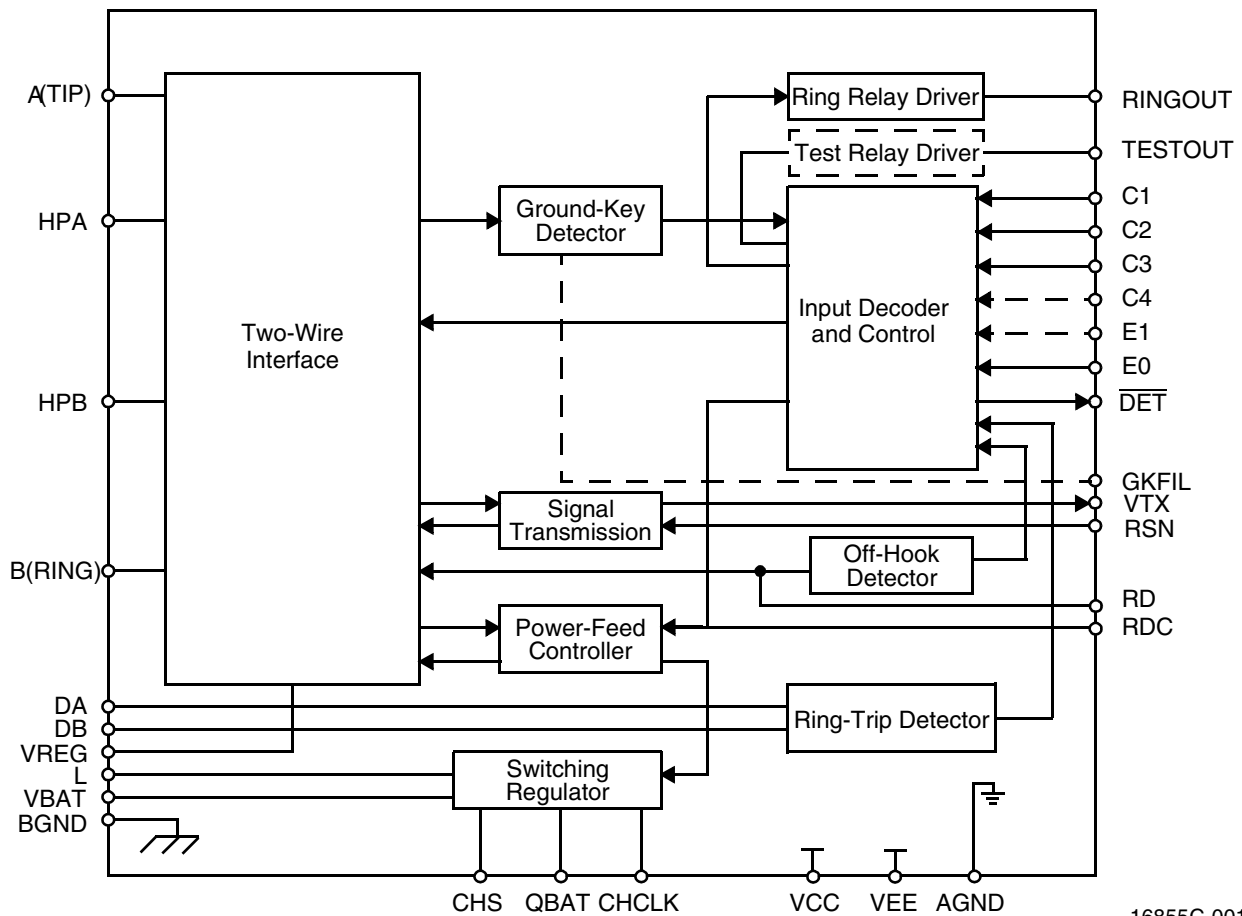

16855C-001

Notes:

1. Am79574—E0 and E1 inputs; ring and test relay drivers sourced internally to BGND.
2. Output amplifier current gain (K_1) = 1000.

ORDERING INFORMATION

Standard Products

Legerity standard products are available in several packages and operating ranges. The order number (Valid Combination) is formed by a combination of the elements below.

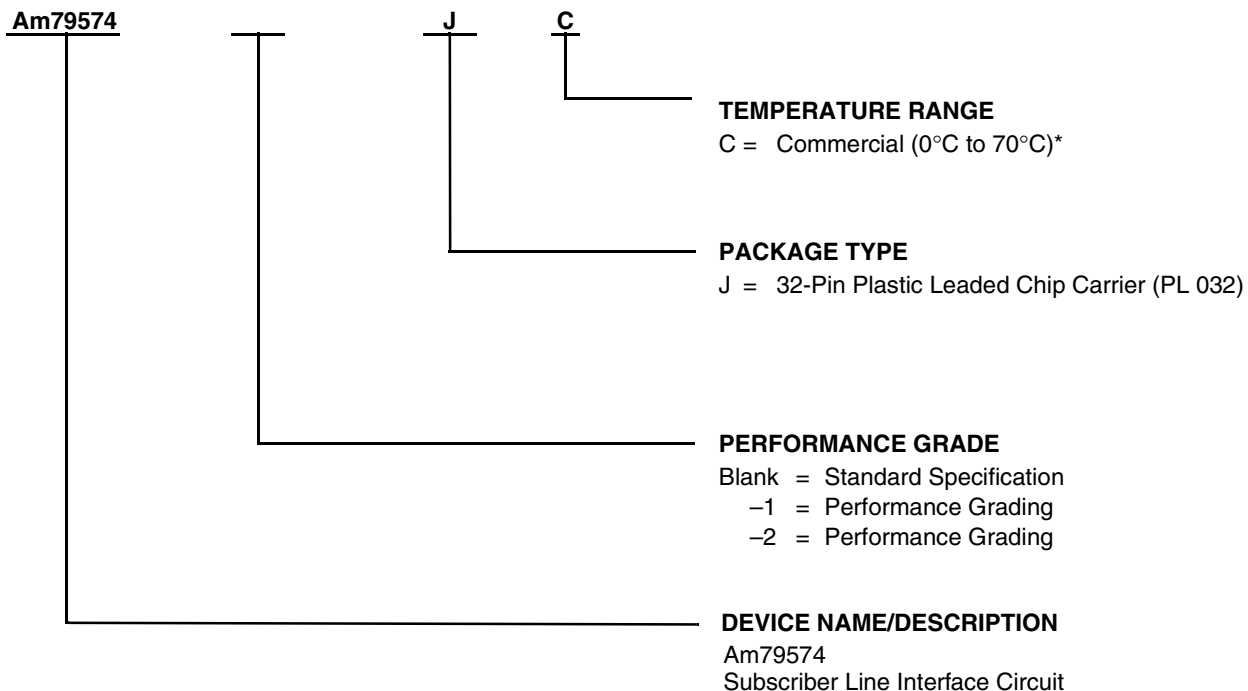

Valid Combinations		
Am79574	-1	JC
	-2	

Valid Combinations

Valid Combinations list configurations planned to be supported in volume for this device. Consult the local Legerity sales office to confirm availability of specific valid combinations, to check on newly released combinations, and to obtain additional data on Legerity's standard military-grade products.

Note:

* Functionality of the device from 0°C to +70°C is guaranteed by production testing. Performance from -40°C to +85°C is guaranteed by characterization and periodic sampling of production units.

CONNECTION DIAGRAM

Top View

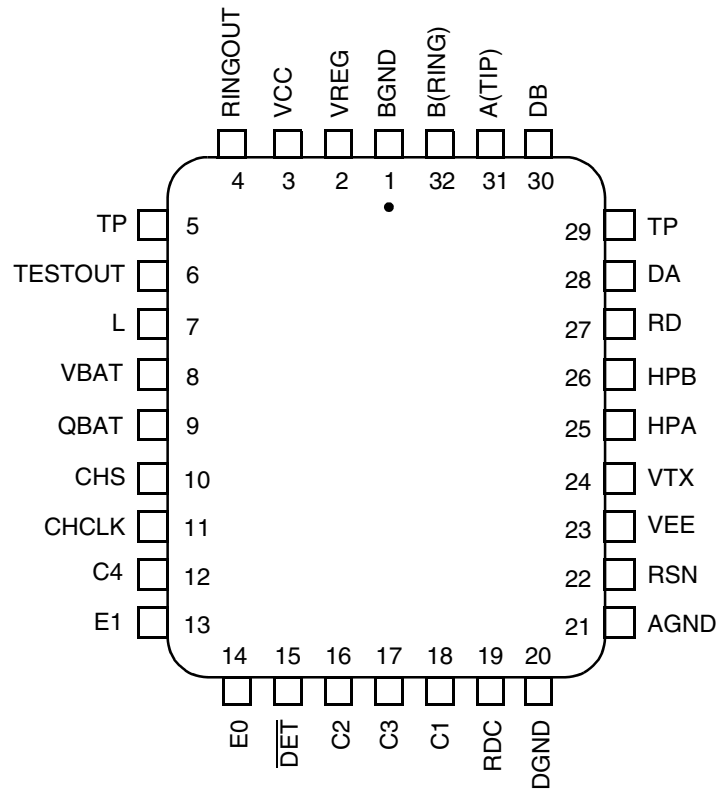

Notes:

1. Pin 1 is marked for orientation.
2. TP is a thermal conduction pin tied to substrate (QBAT).

PIN DESCRIPTIONS

Pin Names	Type	Description
AGND	Gnd	Analog (quiet) ground
A(TIP)	Output	Output of A(TIP) power amplifier
BGND	Gnd	Battery (power) ground
B(RING)	Output	Output of B(RING) power amplifier
C3–C1	Input	Decoder. TTL compatible. C3 is MSB and C1 is LSB.
C4	Input	Test relay driver command. TTL compatible. Logic Low enables the driver.
CHCLK	Input	Chopper clock. Input to switching regulator (TTL compatible). Freq = 256 kHz (Nominal).
CHS	Input	Chopper stabilization. Connection for external stabilization components.
DA	Input	Ring-trip negative. Negative input to ring-trip comparator.
DB	Input	Ring-trip positive. Positive input to ring-trip comparator.
$\overline{\text{DET}}$	Output	Detector. Logic Low indicates that the selected detector is tripped. Logic inputs C3–C1, E1, and E0 select the detector. Open-collector with a built-in 15 k Ω pull-up resistor.
DGND	Gnd	Digital ground
E0	Input	A logic High enables $\overline{\text{DET}}$. A logic Low disables $\overline{\text{DET}}$.
E1	Input	E1 = High connects the ground-key detector to $\overline{\text{DET}}$, and E1 = Low connects the off-hook or ring-trip detector to $\overline{\text{DET}}$.
HPA	Capacitor	High-pass filter capacitor. A(TIP) side of high-pass filter capacitor.
HPB	Capacitor	High-pass filter capacitor. B(RING) side of high-pass filter capacitor.
L	Output	Switching Regulator Power Transistor. Connection point for filter inductor and anode of catch diode. Has up to 60 V of pulse waveform on it and must be isolated from sensitive circuits. Keep the diode connections short because of the high currents and high di/dt.
QBAT	Battery	Filtered battery supply for the signal processing circuits.
RD	Resistor	Detector resistor. Threshold modification and filter point for the off-hook detector.
RDC	Resistor	DC feed resistor. Connection point for the DC feed current programming network, which also connects to the Receiver Summing Node (RSN). V_{RDC} is negative for normal polarity and positive for reverse polarity.
RINGOUT	Output	Ring relay driver. Sourcing from BGND with internal diode to QBAT.
RSN	Input	The metallic current (AC and DC) between A(TIP) and B(RING) = 1000 x the current into this pin. The networks that program receive gain, two-wire impedance, and feed resistance all connect to this node. This node is extremely sensitive. Route the 256 kHz chopper clock and switch lines away from the RSN node.
TESTOUT	Output	Test relay driver. Source from BGND with internal diode to QBAT.
TP	Thermal	Thermal pin. Connection for heat dissipation. Internally connected to substrate (QBAT). Leave as open circuit or connected to QBAT. In both cases, the TP pins can connect to an area of copper on the board to enhance heat dissipation.
VBAT	Battery	Battery supply. Connected through an external protection diode.
VCC	Power	+5 V power supply.
VEE	Power	–5 V power supply.
VREG	Input	Regulated voltage. Provides negative power supply for power amplifiers, connection point for inductor, filter capacitor, and chopper stabilization.
VTX	Output	Transmit Audio. Unity gain version of the A(TIP) and B(RING) metallic voltage. VTX also sources the two-wire input impedance programming network.

ABSOLUTE MAXIMUM RATINGS

Storage temperature	-55°C to +150°C
V _{CC} with respect to AGND/DGND	-0.4 V to +7.0 V
V _{EE} with respect to AGND/DGND	+0.4 V to -7.0 V
V _{BAT} with respect to AGND/DGND	+0.4 V to -70 V

Note: Rise time of V_{BAT} (dv/dt) must be limited to 27 V/μs or less when Q_{BAT} bypass = 0.33 μF.

BGND with respect to AGND/DGND.. +1.0 V to -3.0 V
A(TIP) or B(RING) to BGND:

Continuous	-70 V to +1.0 V
10 ms (f = 0.1 Hz)	-70 V to +5.0 V
1 μs (f = 0.1 Hz)	-90 V to +10 V
250 ns (f = 0.1 Hz)	-120 V to +15 V
Current from A(TIP) or B(RING).....	±150 mA
Voltage on RINGOUT	BGND to 70 V above Q _{BAT}
Voltage on TESTOUT	BGND to 70 V above Q _{BAT}
Current through relay drivers	60 mA
Voltage on ring-trip inputs (DA and DB)	V _{BAT} to 0 V
Current into ring-trip inputs.....	±10 mA
Peak current into regulator Switch (L pin)	150 mA
Switcher transient peak off Voltage on L pin.....	+1.0 V
C4-C1, E1, CHCLK to AGND/DGND	-0.4 V to V _{CC} + 0.4 V
Maximum power dissipation, (see note)	T _A = 70°C
In 32-pin PLCC package.....	1.74 W

Note: Thermal limiting circuitry on-chip will shut down the circuit at a junction temperature of about 165°C. The device should never be exposed to this temperature. Operation above 145°C junction temperature may degrade device reliability. See the SLIC Packaging Considerations for more information.

Stresses above those listed under Absolute Maximum Ratings may cause permanent device failure. Functionality at or above these limits is not implied. Exposure to Absolute Maximum Ratings for extended periods may affect device reliability.

OPERATING RANGES

Commercial (C) Devices

Ambient temperature	0°C to +70°C*
V _{CC}	4.75 V to 5.25 V
V _{EE}	-4.75 V to -5.25 V
V _{BAT}	-40 V to -58 V
AGND/DGND.....	0 V
BGND with respect to AGND/DGND	-100 mV to +100 mV
Load Resistance on VTX to ground.....	10 kΩ min

Operating Ranges define those limits between which the functionality of the device is guaranteed.

* Functionality of the device from 0°C to +70°C is guaranteed by production testing. Performance from -40°C to +85°C is guaranteed by characterization and periodic sampling of production units.

ELECTRICAL CHARACTERISTICS

Description	Test Conditions (See Note 1)	Min	Typ	Max	Unit	Note
Analog (V_{TX}) output impedance			3		Ω	4
Analog (V_{TX}) output offset	0°C to 70°C	-35 -30		+35 +30	mV	— —
	-40°C to +85°C	-40 -35		+40 +35		4 4
Analog (RSN) input impedance			1	20	Ω	4
Longitudinal impedance at A or B	300 Hz to 3.4 kHz			35		
Overload level $Z_{2WIN} = 600$ to 900Ω	4-wire 2-wire	-3.1		+3.1	Vpk	2
Transmission Performance, 2-Wire Impedance						
2-wire return loss (See Test Circuit D)	300 Hz to 500 Hz 500 Hz to 2.5 kHz 2500 Hz to 3.4 kHz	26 26 20			dB	4, 11
Longitudinal Balance (2-Wire and 4-Wire, See Test Circuit C)						
$R_L = 600 \Omega$	300 Hz to 3.4 kHz	48			dB	
Longitudinal to metallic L-T, L-4	300 Hz to 3.4 kHz	-1* 52				
Longitudinal to metallic L-T, L-4	200 Hz to 1 kHz					
	normal polarity 0°C to +70°C	-2* 63				
	normal polarity -40°C to +85°C	-2 58				
	reverse polarity	-2 54				
Longitudinal to metallic L-T, L-4	1 kHz to 3.4 kHz					
	normal polarity 0°C to +70°C	-2* 58				
	normal polarity -40°C to +85°C	-2 54				
	reverse polarity	-2 54				
Longitudinal signal generation 4-L	300 Hz to 800 Hz 300 Hz to 800 Hz	40 -1* 42				
Longitudinal current capability per wire	Active state OHT state		25 18		mArms	4
Insertion Loss (2- to 4-Wire and 4- to 2-Wire, See Test Circuits A and B)						
Gain accuracy	0 dBm, 1 kHz, 0°C to +70°C	-0.15		+0.15	dB	—
	0 dBm, 1 kHz, -40°C to +85°C	-0.20		+0.20		4
	0 dBm, 1 kHz, 0°C to +70°C	-1* -0.1		+0.1		—
	0 dBm, 1 kHz, -40°C to +85°C	-1 -0.15		+0.15		4
Variation with frequency	300 Hz to 3.4 kHz					
	Relative to 1 kHz					
	0°C to +70°C -40°C to +85°C	-0.1 -0.15		+0.1 +0.15		— 4
Gain tracking	+7 dBm to -55 dBm					
	0°C to +70°C	-0.1		+0.1		—
	-40°C to +85°C	-0.15		+0.15		4

Notes:

* P.G. = Performance Grade

-2 grade performance parameters are equivalent to -1 performance parameters except where indicated.

ELECTRICAL CHARACTERISTICS (continued)

Description	Test Conditions (See Note 1)	Min	Typ	Max	Unit	Note
Balance Return Signal (4- to 4-Wire, See Test Circuit B)						
Gain accuracy	0 dBm, 1 kHz, 0°C to +70°C	-0.15		+0.15	dB	—
	0 dBm, 1 kHz, -40°C to +85°C	-0.20		+0.20		4
	0 dBm, 1 kHz, 0°C to +70°C -1*	-0.1		+0.1		—
	0 dBm, 1 kHz, -40°C to +85°C -1	-0.15		+0.15		4
Variation with frequency	300 Hz to 3.4 kHz Relative to 1 kHz 0°C to +70°C -40°C to +85°C	-0.1 -0.15		+0.1 +0.15	dB	— 4
Gain tracking	+7 dBm to -55 dBm 0°C to +70°C -40°C to +85°C	-0.1 -0.15		+0.1 +0.15		— 4
Group delay	f = 1 kHz		5.3		μs	4
Total Harmonic Distortion (2- to 4-Wire or 4- to 2-Wire, See Test Circuits A and B)						
Total harmonic distortion	0 dBm, 300 Hz to 3.4 kHz +9 dBm, 300 Hz to 3.4 kHz		-64 -55	-50 -40	dB	
Idle Channel Noise						
C-message weighted noise	2-wire, 0°C to +70°C		+7	+15	dBmrc	—
	2-wire, 0°C to +70°C -1*		+7	+12		—
	2-wire, -40°C to +85°C		+7	+15		4
	4-wire, 0°C to +70°C		+7	+15		—
Psophometric weighted noise	2-wire, 0°C to +70°C		-83	-75	dBmp	7
	2-wire, 0°C to +70°C -1*		-83	-78		—
	2-wire, -40°C to +85°C		-83	-75		4, 7
	4-wire, 0°C to +70°C		-83	-75		7
Single Frequency Out-of-Band Noise (See Test Circuit E)	4-wire, 0°C to +70°C -1*		-83	-78	dBm	—
	4-wire, -40°C to +85°C		-83	-75		4, 7
	4-wire, 0°C to +70°C		-83	-75		—
	4-wire, -40°C to +85°C		-83	-75		4, 7
Metallic	4 kHz to 9 kHz		-76		dBm	4, 5, 9
	9 kHz to 1 MHz		-76			4, 5, 9
	256 kHz and harmonics		-57			4, 5
Longitudinal	1 kHz to 15 kHz		-70		dBm	4, 5, 9
	Above 15 kHz		-85			4, 5, 9
	256 kHz and harmonics		-57			4, 5
Line Characteristics (See Figure 1) BAT = -48 V, R_L = 600 Ω and 900 Ω, R_{FEED} = 800 Ω						
Apparent battery voltage	Active state	47	50	53	V	
Loop current accuracy	Active state	-7.5		+7.5	%	
Loop current—Tip Open	R _L = 600 Ω			1.0	mA	
Loop current—Open Circuit	R _L = 0 Ω			1.0		
Loop current limit accuracy	OHT state Active state	-20		+20	%	10
Fault current limit, I _L LIM (I _{AX} + I _{BX})	A and B shorted to GND			130	mA	

ELECTRICAL CHARACTERISTICS (continued)

Description	Test Conditions (See Note 1)	Min	Typ	Max	Unit	Note
Power Dissipation, BAT = -48 V, Normal Polarity						
On-hook Open Circuit state	-1*		35 35	120 80	mW	
On-hook OHT state	-1*		135 135	250 200		
On-hook Active state	-1*		200 200	400 300		
Off-hook OHT state	R _L = 600 Ω		500	750		
Off-hook Active state	R _L = 600 Ω		650	1000		
Supply Currents						
V _{CC} on-hook supply current	Open Circuit state OHT state Active state		3.0 6.0 8.0	4.5 10.0 13.0	mA	
V _{EE} on-hook supply current	Open Circuit state OHT state Active state		1.0 2.3 3.0	2.3 3.7 6.0		
V _{BAT} on-hook supply current	Open Circuit state OHT state Active state		0.4 3.2 4.5	1.0 5.5 7.0		
Power Supply Rejection Ratio (V_{RIPPLE} = 50 mVrms)						
V _{CC}	50 Hz to 3.4 kHz	-1*	25 30	45 45	dB	6, 7
	3.4 kHz to 50 kHz	-1*	22 25	35 40		
V _{EE}	50 Hz to 3.4 kHz	-1*	20 25	40 40		
	3.4 kHz to 50 kHz	-1*	10 10	25 25		
V _{BAT}	50 Hz to 3.4 kHz	-1*	27 30	45 45		
	3.4 kHz to 50 kHz	-1*	20 25	40 40		
Off-Hook Detector						
Current threshold accuracy	I _{DET} = 365/R _D Nominal	-20		+20	%	
Ground-Key Detector Thresholds, Active State, BAT = -48 V (See Test Circuit F)						
Ground-key resistance threshold	B(RING) to GND	2.0	5.0	10.0	kΩ	
Ground-key current threshold	B(RING) to GND		9		mA	8
	Midpoint to GND		9			
Ring-Trip Detector Input						
Bias current		-5	-0.05		μA	
Offset voltage	Source resistance 0 Ω to 2 MΩ	-50	0	+50	mV	12
Logic Inputs (C4-C1, E0, E1, and CHCLK)						
Input High voltage		2.0			V	
Input Low voltage				0.8		
Input High current	All inputs except E1	-75		40	μA	
Input High current	Input E1	-75		45		
Input Low current		-0.4			mA	

ELECTRICAL CHARACTERISTICS (continued)

Description	Test Conditions (See Note 1)	Min	Typ	Max	Unit	Note
Logic Output (\overline{DET})						
Output Low voltage	$I_{OUT} = 0.8 \text{ mA}$			0.4	V	
Output High voltage	$I_{OUT} = -0.1 \text{ mA}$	2.4				
Relay Driver Outputs (RINGOUT, TESTOUT)						
On voltage	50 mA source	BGND - 2	BGND -.95		V	
Off leakage			0.5	100	μA	
Clamp voltage	50 mA sink	$Q_{BAT} - 2$			V	

RELAY DRIVER SCHEMATICS

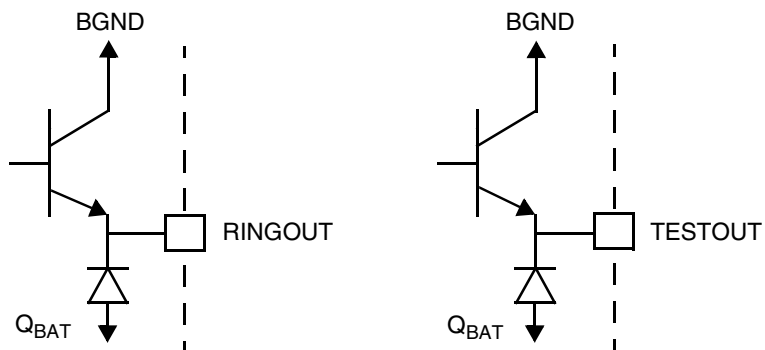

SWITCHING CHARACTERISTICS

Symbol	Parameter	Test Conditions	Temperature Range	Min	Typ	Max	Unit	Note
*tgkde	E1 Low to \overline{DET} High (E0 = 1)	Ground-Key Detect state R_L open, R_G connected (See Figure H)	0°C to +70°C			3.8	μs	4
	E1 Low to \overline{DET} Low (E0 = 1)		-40°C to +85°C			4.0		
tgkdd	E0 High to \overline{DET} Low (E1 = 0)		0°C to +70°C			1.1		
tgkd0	E0 Low to \overline{DET} High (E1 = 0)	-40°C to +85°C			1.6			
*tshde	E1 High to \overline{DET} Low (E0 = 1)	Switchhook Detect state $R_L = 600 \Omega$, R_G open (See Figure G)	0°C to +70°C			1.2		
	E1 High to \overline{DET} High (E0 = 1)		-40°C to +85°C			1.7		
*tshdd	E0 High to \overline{DET} Low (E1 = 1)		0°C to +70°C			3.8		
*tshd0	E0 Low to \overline{DET} High (E1 = 1)	-40°C to +85°C			4.0			
			0°C to +70°C			1.1		
			-40°C to +85°C			1.6		
			0°C to +70°C			3.8		
			-40°C to +85°C			4.0		

Note:

E1 is internally connected to a logical 0.

SWITCHING WAVEFORMS

E1 to $\overline{\text{DET}}^*$

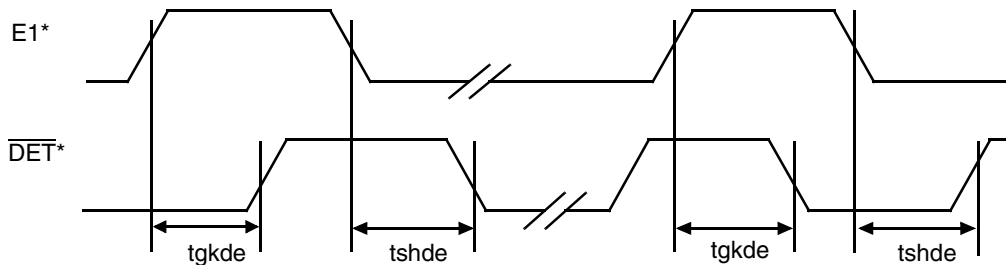

E0 to $\overline{\text{DET}}$

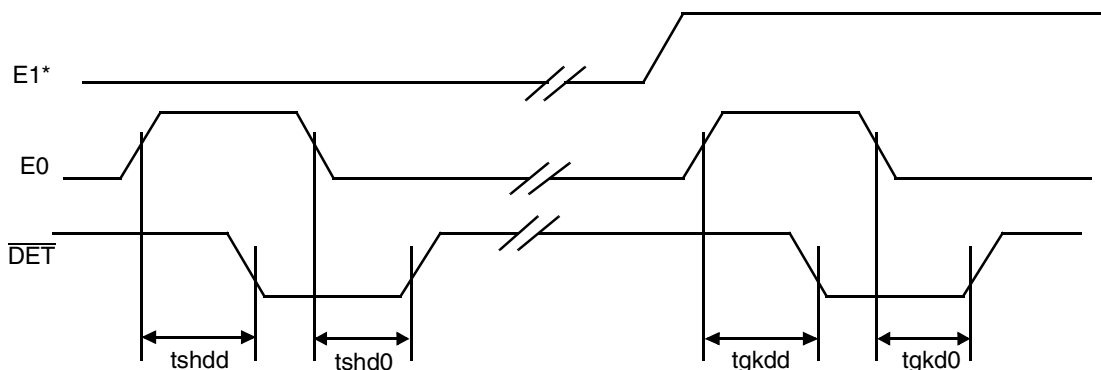

Notes:

* E1 is internally connected to a logical 0.

1. All delays measured at 1.4 V level.

Notes:

1. Unless otherwise noted, test conditions are $BAT = -48\text{ V}$, $V_{CC} = +5\text{ V}$, $V_{EE} = -5\text{ V}$, $R_L = 600\ \Omega$, $C_{HP} = 0.22\ \mu\text{F}$, $R_{DC1} = R_{DC2} = 20\ \text{k}\Omega$, $C_{DC} = 0.1\ \mu\text{F}$, $R_d = 51.1\ \text{k}\Omega$, no fuse resistors, two-wire AC output impedance, programming impedance (Z_T) = 600 k Ω resistive, receive input summing impedance (Z_{RX}) = 300 k Ω resistive. (See Table 2 for component formulas.)
2. Overload level is defined when THD = 1%.
3. Balance return signal is the signal generated at V_{TX} by V_{RX} . This specification assumes that the two-wire AC load impedance matches the impedance programmed by Z_T .
4. Not tested in production. This parameter is guaranteed by characterization or correlation to other tests.
5. These tests are performed with a longitudinal impedance of 90 Ω and metallic impedance of 300 Ω for frequencies below 12 kHz and 135 Ω for frequencies greater than 12 kHz. These tests are extremely sensitive to circuit board layout.
6. This parameter is tested at 1 kHz in production. Performance at other frequencies is guaranteed by characterization.
7. When the SLIC is in the anti-sat 2 operating region, this parameter is degraded. The exact degradation depends on system design. The anti-sat 2 region occurs at high loop resistances when $|V_{BAT}| - |V_{AX} - V_{BX}|$ is less than 14 V.
8. Midpoint is defined as the connection point between two 300 Ω series resistors connected between A(TIP) and B(RING).
9. Fundamental and harmonics from 256 kHz switch-regulator chopper are not included.
10. Calculate loop-current limit using the following equations:

In OHT state:
$$I_{\text{LIMIT}} = 0.5 \frac{V_{\text{APPARENT}}}{R_{\text{FEED}}}$$

In Active state:
$$I_{\text{LIMIT}} = 0.8 \frac{V_{\text{APPARENT}}}{R_{\text{FEED}}}$$

11. Assumes the following Z_T network:

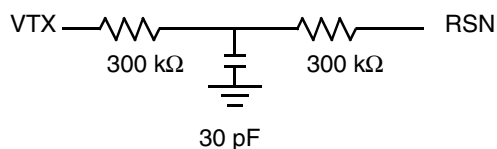

12. Tested with 0Ω source impedance. $2 M\Omega$ is specified for system design purposes only.

13. Group delay can be considerably reduced by using a Z_T network such as that shown in Note 11 above. The network reduces the group delay to less than $2 \mu\text{s}$. The effect of group delay on linecard performance may be compensated for by using QSLAC™ or DSLAC™ devices.

Table 1. SLIC Decoding

State	C3 C2 C1	Two-Wire Status	$\overline{\text{DET}}$ Output	
			E0 = 1* E1 = 0	E0 = 1* E1 = 1
0	0 0 0	Open Circuit	Ring trip	Ring trip
1	0 0 1	Ringing	Ring trip	Ring trip
2	0 1 0	Active	Loop detector	Ground key
3	0 1 1	On-hook TX (OHT)	Loop detector	Ground key
4	1 0 0	Tip Open	Loop detector	—
5	1 0 1	Reserved	Loop detector	—
6	1 1 0	Active Polarity Reversal	Loop detector	Ground key
7	1 1 1	OHT Polarity Reversal	Loop detector	Ground key

Note:

* A logic Low on E0 disables the $\overline{\text{DET}}$ output into the Open Collector state.

Table 2. User-Programmable Components

$Z_T = 1000(Z_{2\text{WIN}} - 2R_F)$	Z_T is connected between the VTX and RSN pins. The fuse resistors are R_F , and $Z_{2\text{WIN}}$ is the desired 2-wire AC input impedance. When computing Z_T , the internal current amplifier pole and any external stray capacitance between VTX and RSN must be taken into account.
$Z_{\text{RX}} = \frac{Z_L}{G_{42\text{L}}} \cdot \frac{1000 \cdot Z_T}{Z_T + 1000(Z_L + 2R_F)}$	Z_{RX} is connected from VRX to the RSN pin, Z_T is defined above, and $G_{42\text{L}}$ is the desired receive gain.
$R_{\text{DC1}} + R_{\text{DC2}} = 50(R_{\text{FEED}} - 2R_F)$ $C_{\text{DC}} = 1.5 \text{ ms} \cdot \frac{R_{\text{DC1}} + R_{\text{DC2}}}{R_{\text{DC1}} \cdot R_{\text{DC2}}}$	R_{DC1} , R_{DC2} , and C_{DC} form the network connected to the RDC pin. R_{DC1} and R_{DC2} are approximately equal.
$R_D = \frac{365}{I_T}, \quad C_D = \frac{0.5 \text{ ms}}{R_D}$	R_D and C_D form the network connected from RD to -5 V and I_T is the threshold current between on hook and off hook.

DC FEED CHARACTERISTICS

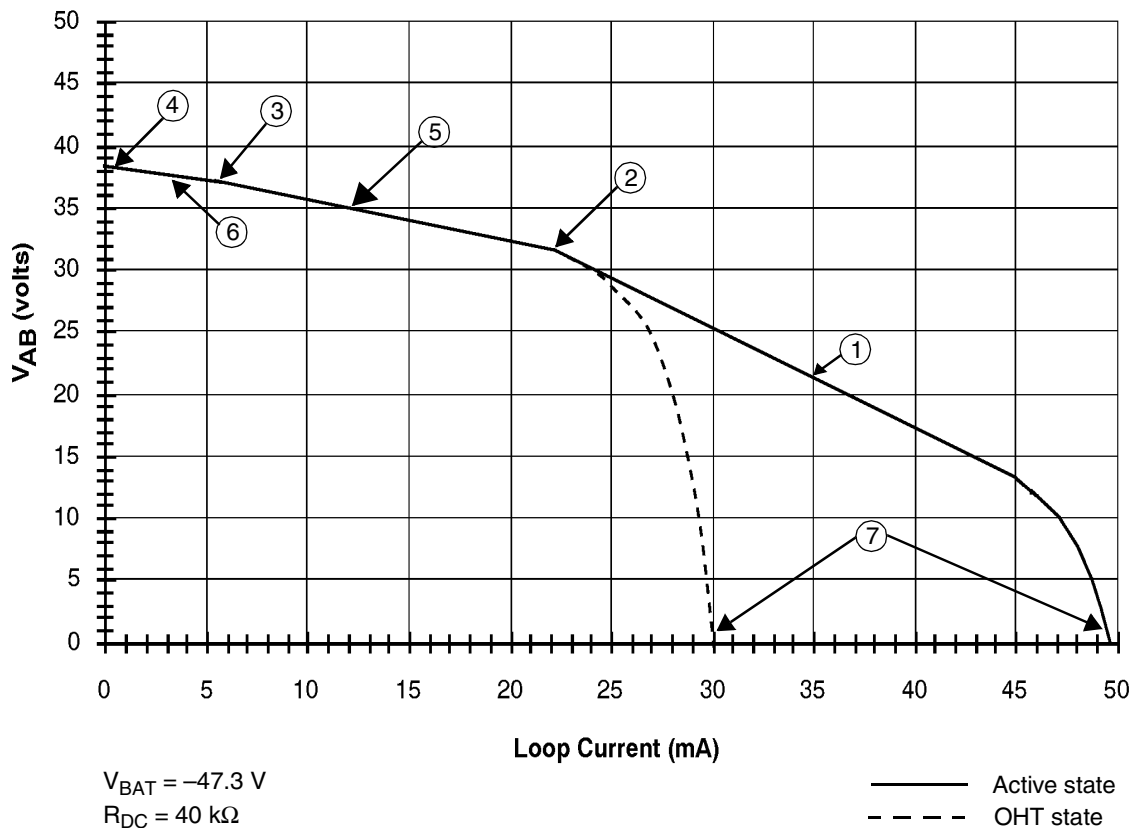

Notes:

1. Constant-resistance feed region: $V_{AB} = 50 - I_L \left(\frac{R_{DC}}{50} \right)$
2. Anti-sat -1 turn-on: $V_{AB} = 31.8 \text{ V}$
3. Anti-sat -2 turn-on: $V_{AB} = 1.077 |V_{BAT}| - 12.538$
4. Open circuit voltage: $V_{AB} = 0.377 |V_{BAT}| + 20.48, \quad |V_{BAT}| < 50.2 \text{ V}$
 $V_{AB} = 39.39 \text{ V} \quad |V_{BAT}| \geq 50.2 \text{ V}$
5. Anti-sat -1 region: $V_{AB} = 39.39 - I_L \left(\frac{R_{DC}}{118.3} \right)$
6. Anti-sat -2 region: $V_{AB} = 0.377 |V_{BAT}| + 20.48 - I_L \left(\frac{R_{DC}}{200} \right)$
7. Current Limit:

Active state,	$I_L = 0.8 \left(\frac{2500}{R_{DC}} \right)$
OHT state,	$I_L = 0.5 \left(\frac{2500}{R_{DC}} \right)$

a. $V_A - V_B$ (V_{AB}) Voltage vs. Loop Current (Typical)

DC FEED CHARACTERISTICS (continued)

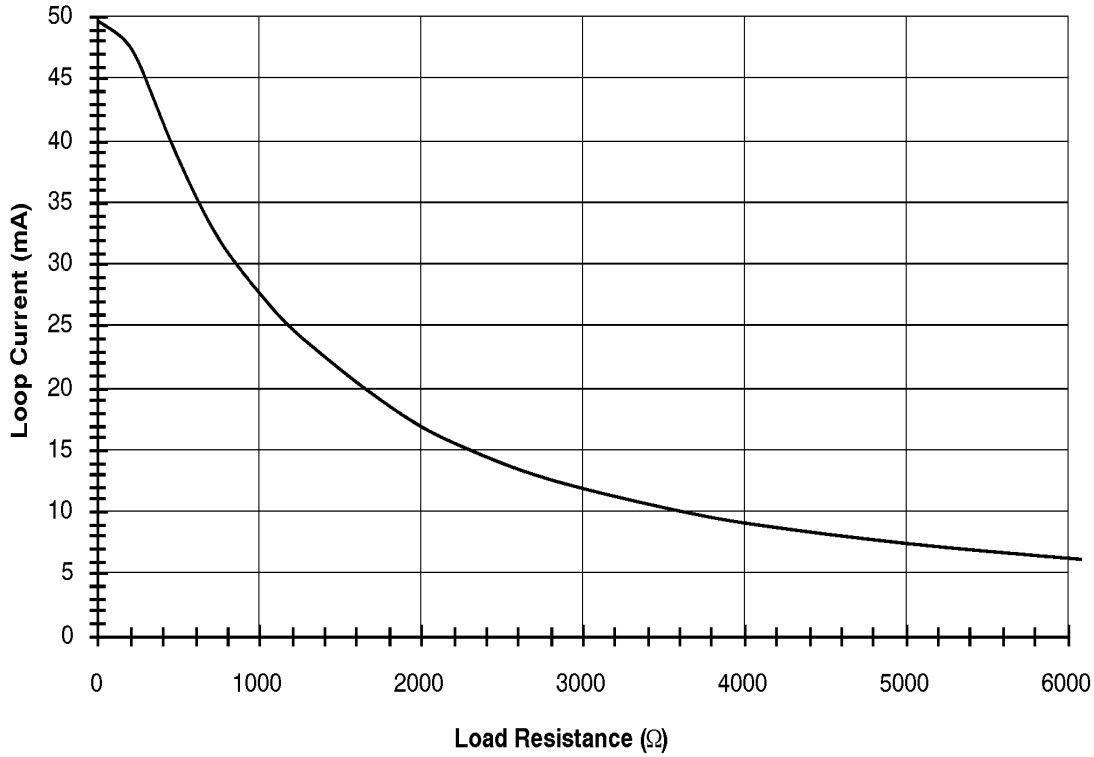

$V_{BAT} = -47.3 \text{ V}$
 $R_{DC} = 40 \text{ k}\Omega$

b. Loop Current vs. Load Resistance (Typical)

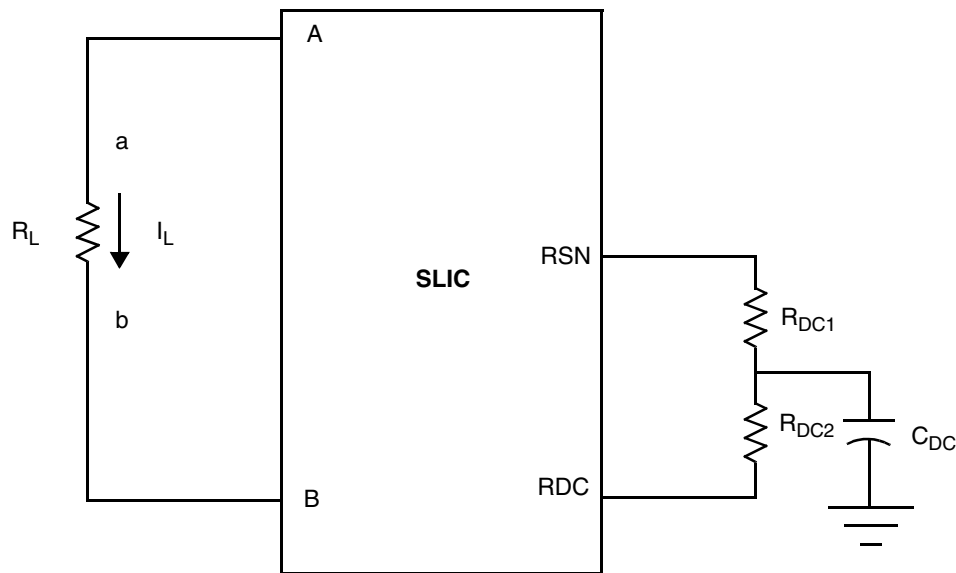

Feed resistance programmed by R_{DC1} and R_{DC2}

c. Feed Programming

Figure 1. DC Feed Characteristics

TEST CIRCUITS

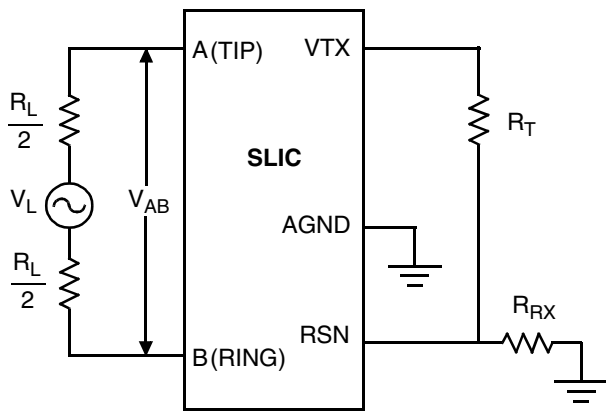

$$I_{L2-4} = -20 \log (V_{TX} / V_{AB})$$

A. Two- to Four-Wire Insertion Loss

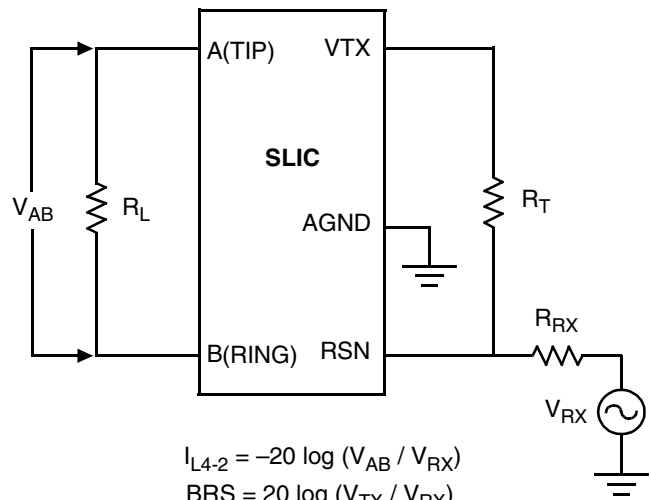

$$I_{L4-2} = -20 \log (V_{AB} / V_{RX})$$

$$BRS = 20 \log (V_{TX} / V_{RX})$$

B. Four- to Two-Wire Insertion Loss and Balance Return Signal

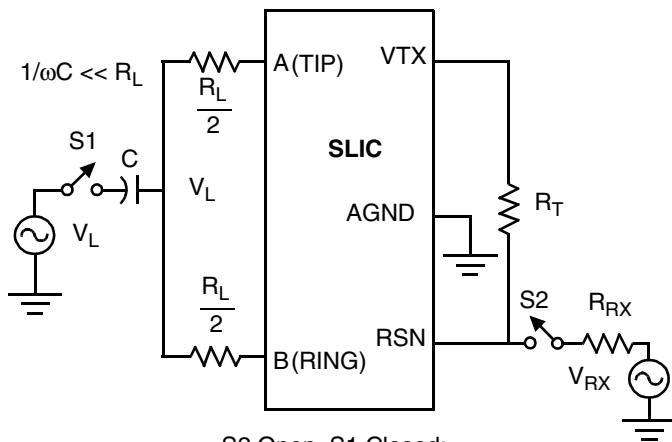

S2 Open, S1 Closed:

$$L-T \text{ Long. Bal.} = 20 \log (V_{AB} / V_L)$$

$$L-4 \text{ Long. Bal.} = 20 \log (V_{TX} / V_L)$$

S2 Closed, S1 Open:

$$4-L \text{ Long. Sig. Gen.} = 20 \log (V_L / V_{RX})$$

C. Longitudinal Balance

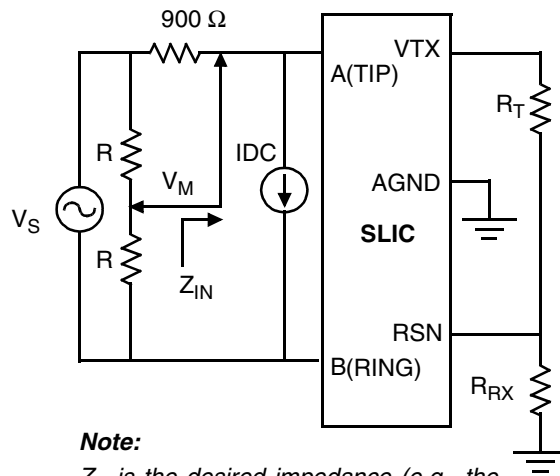

Note:

Z_D is the desired impedance (e.g., the characteristic impedance of the line).

$$R_L = -20 \log (2 V_M / V_S)$$

D. Two-Wire Return Loss Test Circuit

TEST CIRCUITS (continued)

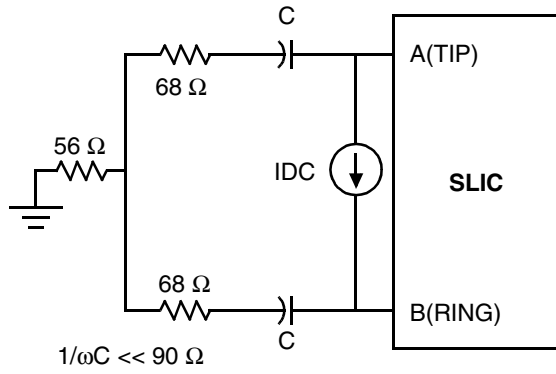

E. Single-Frequency Noise

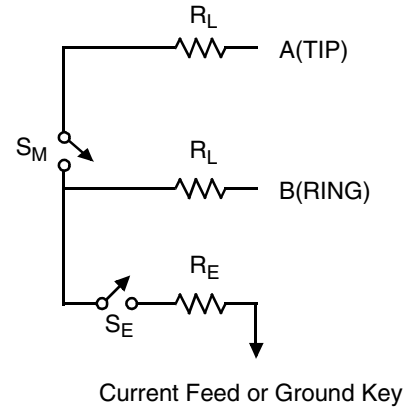

F. Ground-Key Detection

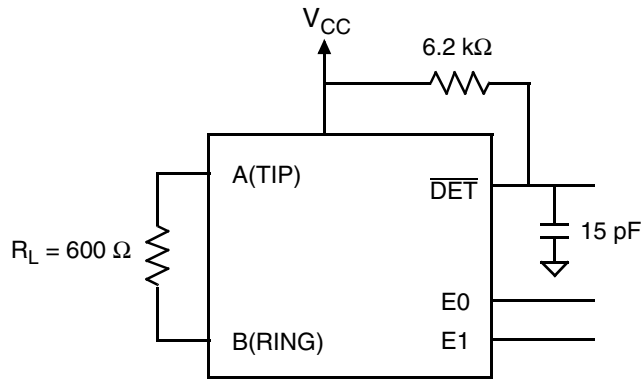

G. Loop-Detector Switching

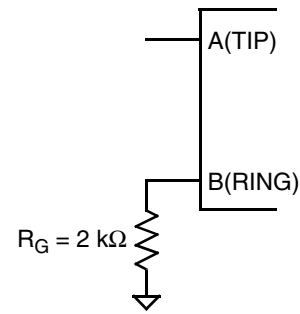

H. Ground-Key Switching

PHYSICAL DIMENSIONS

PL032

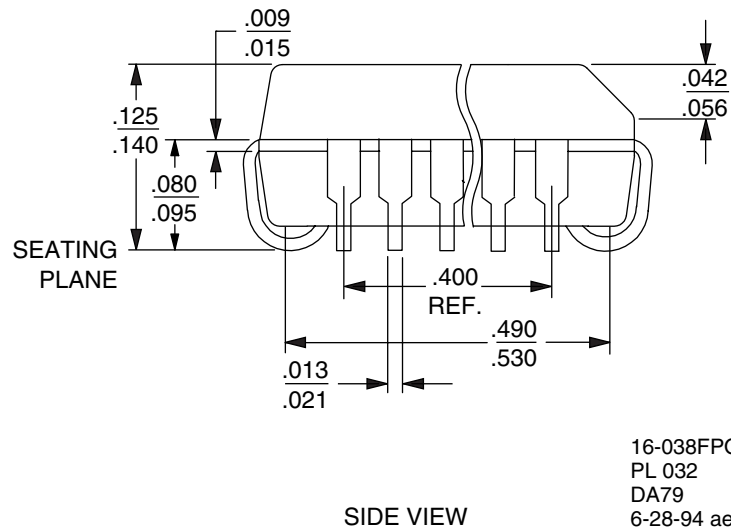
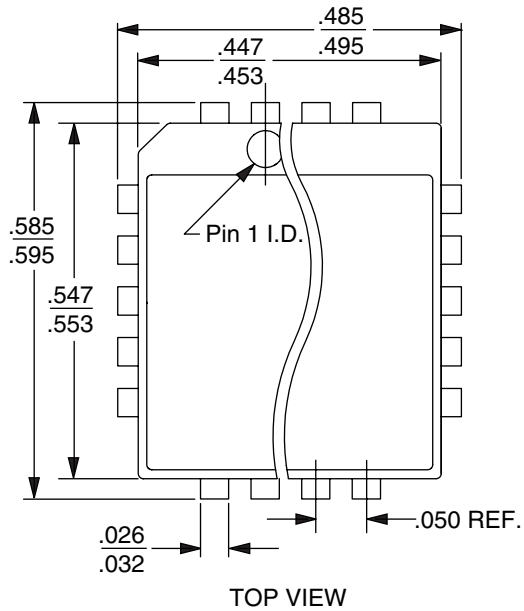

16-038FPO-5
 PL 032
 DA79
 6-28-94 ae

REVISION SUMMARY

Revision B to Revision C

- Minor changes were made to the data sheet style and format to conform to Legerity standards.

Revision C to Revision D

- In the Pin Description table, inserted/changed TP pin description to: "Thermal pin. Connection for heat dissipation. Internally connected to substrate (QBAT). Leave as open circuit or connected to QBAT. In both cases, the TP pins can connect to an area of copper on the board to enhance heat dissipation."
- Minor changes were made to the data sheet style and format to conform to Legerity standards.

Revision D to Revision E

- The physical dimensions (PL032) were added to the Physical Dimensions section.
- Deleted the Ceramic DIP and Plastic DIP parts (Am79571 and Am79573) and references to them.
- Updated the Pin Description table to correct inconsistencies.

Notes:

www.legerity.com

Legerity provides silicon solutions that enhance the performance, speeds time-to-market, and lowers the system cost of our customers' products. By combining process, design, systems architecture, and a complete set of software and hardware support tools with unparalleled factory and worldwide field applications support, Legerity ensures its customers enjoy a smoother design experience. It is this commitment to our customers that places Legerity in a class by itself.

The contents of this document are provided in connection with Legerity, Inc. products. Legerity makes no representations or warranties with respect to the accuracy or completeness of the contents of this publication and reserves the right to make changes to specifications and product descriptions at any time without notice. No license, whether express, implied, arising by estoppel or otherwise, to any intellectual property rights is granted by this publication. Except as set forth in Legerity's Standard Terms and Conditions of Sale, Legerity assumes no liability whatsoever, and disclaims any express or implied warranty, relating to its products including, but not limited to, the implied warranty of merchantability, fitness for a particular purpose, or infringement of any intellectual property right.

Legerity's products are not designed, intended, authorized or warranted for use as components in systems intended for surgical implant into the body, or in other applications intended to support or sustain life, or in any other application in which the failure of Legerity's product could create a property or environmental damage may occur. Legerity reserves the right to discontinue or make changes to its products at any time without notice.

© 1999 Legerity, Inc.
All rights reserved.

Trademarks

Legerity, the Legerity logo, and combinations thereof, and DSLAC and QSLAC are trademarks of Legerity, Inc.

Other product names used in this publication are for identification purposes only and may be trademarks of their respective companies.



P.O. Box 18200
Austin, Texas 78760-8200

Telephone: (512) 228-5400
Fax: (512) 228-5510
North America Toll Free: (800) 432-4009

*To contact the Legerity Sales Office nearest you,
or to download or order product literature, visit
our website at **www.legerity.com**.*

*To order literature in North America, call:
(800) 572-4859
or email:
americalit@legerity.com*

*To order literature in Europe or Asia, call:
44-0-1179-341607
or email:
Europe — eurolit@legerity.com
Asia — asialit@legerity.com*