

IGBT

IXGH 20N100
IXGT 20N100

$V_{CES} = 1000 \text{ V}$
 $I_{C25} = 40 \text{ A}$
 $V_{CE(sat)} = 3.0 \text{ V}$
 $t_{fi(typ)} = 280 \text{ ns}$

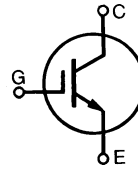

Preliminary data

| Symbol | Test Conditions | Maximum Ratings | |
|---------------------|---|----------------------------------|------------------|
| V_{CES} | $T_J = 25^\circ\text{C to } 150^\circ\text{C}$ | 1000 | V |
| V_{CGR} | $T_J = 25^\circ\text{C to } 150^\circ\text{C}; R_{GE} = 1 \text{ M}\Omega$ | 1000 | V |
| V_{GES} | Continuous | ± 20 | V |
| V_{GEM} | Transient | ± 30 | V |
| I_{C25} | $T_C = 25^\circ\text{C}$ | 40 | A |
| I_{C90} | $T_C = 90^\circ\text{C}$ | 20 | A |
| I_{CM} | $T_C = 25^\circ\text{C}, 1 \text{ ms}$ | 80 | A |
| SSOA (RBSOA) | $V_{GE} = 15 \text{ V}, T_{VJ} = 125^\circ\text{C}, R_G = 47 \Omega$ Clamped inductive load, $L = 100 \mu\text{H}$ | $I_{CM} = 40$ @ $0.8 V_{CES}$ | A |
| P_C | $T_C = 25^\circ\text{C}$ | 150 | W |
| T_J | | -55 ... +150 | $^\circ\text{C}$ |
| T_{JM} | | 150 | $^\circ\text{C}$ |
| T_{stg} | | -55 ... +150 | $^\circ\text{C}$ |
| | Maximum Lead temperature for soldering 1.6 mm (0.062 in.) from case for 10 s | 300 | $^\circ\text{C}$ |
| | Maximum Tab temperature for soldering SMD devices for 10 s | 260 | $^\circ\text{C}$ |
| M_d | Mounting torque (M3) | 1.13/10 Nm/lb.in. | |
| Weight | | TO-247 AD | 6 g |
| | | TO-268 | 4 g |

TO-268 (IXGT)

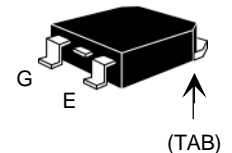

TO-247 AD (IXGH)

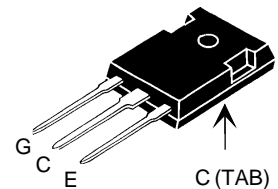

G = Gate, C = Collector,
E = Emitter, TAB = Collector

Features

- International standard packages JEDEC TO-268 surface and JEDEC TO-247 AD
- High current handling capability
- MOS Gate turn-on - drive simplicity

Applications

- AC motor speed control
- DC servo and robot drives
- DC choppers
- Uninterruptible power supplies (UPS)
- Switched-mode and resonant-mode power supplies
- Capacitor discharge

Advantages

- High power density
- Suitable for surface mounting
- Easy to mount with 1 screw, (isolated mounting screw hole)

| Symbol | Test Conditions | Characteristic Values ($T_J = 25^\circ\text{C}$, unless otherwise specified) | | |
|---------------|---|---|------|---------------------------|
| | | min. | typ. | max. |
| BV_{CES} | $I_C = 1 \text{ mA}, V_{GE} = 0 \text{ V}$ | 1000 | | V |
| $V_{GE(th)}$ | $I_C = 250 \mu\text{A}, V_{CE} = V_{GE}$ | 2.5 | | V |
| I_{CES} | $V_{CE} = V_{CES}, V_{GE} = 0 \text{ V}$ | | | 250 μA 1 mA |
| I_{GES} | $V_{CE} = 0 \text{ V}, V_{GE} = \pm 20 \text{ V}$ | | | $\pm 100 \text{ nA}$ |
| $V_{CE(sat)}$ | $I_C = I_{C90}, V_{GE} = 15 \text{ V}$ | 2.2 | 3.0 | V |

| Symbol | Test Conditions | Characteristic Values ($T_J = 25^\circ\text{C}$, unless otherwise specified) | | | |
|--------------|--|---|------|------|-----|
| | | min. | typ. | max. | |
| g_{fs} | $I_C = I_{C90}$; $V_{CE} = 10\text{ V}$, Pulse test, $t \leq 300\ \mu\text{s}$, duty cycle $\leq 2\%$ | 12 | 16 | S | |
| $I_{C(ON)}$ | $V_{GE} = 10\text{ V}$, $V_{CE} = 10\text{ V}$ | | 90 | A | |
| C_{ies} | $V_{CE} = 25\text{ V}$, $V_{GE} = 0\text{ V}$, $f = 1\text{ MHz}$ | | 1750 | pF | |
| C_{oes} | | | 100 | pF | |
| C_{res} | | | 38 | pF | |
| Q_g | $I_C = I_{C90}$, $V_{GE} = 15\text{ V}$, $V_{CE} = 0.5 V_{CES}$ | | 73 | nC | |
| Q_{ge} | | | 13 | nC | |
| Q_{gc} | | | 26 | nC | |
| $t_{d(on)}$ | Inductive load, $T_J = 25^\circ\text{C}$ $I_C = I_{C90}$, $V_{GE} = 15\text{ V}$, $L = 100\ \mu\text{H}$, $V_{CE} = 0.8 V_{CES}$, $R_G = R_{off} = 47\ \Omega$ Remarks: Switching times may increase for V_{CE} (Clamp) $> 0.8 \cdot V_{CES}$, higher T_J or increased R_G | | 30 | ns | |
| t_{ri} | | | 30 | ns | |
| $t_{d(off)}$ | | | 350 | 700 | ns |
| t_{fi} | | | 280 | 700 | ns |
| E_{off} | | | 3.5 | 8.0 | mJ |
| $t_{d(on)}$ | Inductive load, $T_J = 125^\circ\text{C}$ $I_C = I_{C90}$, $V_{GE} = 15\text{ V}$, $L = 100\ \mu\text{H}$, $V_{CE} = 0.8 V_{CES}$, $R_G = R_{off} = 47\ \Omega$ Remarks: Switching times may increase for V_{CE} (Clamp) $> 0.8 \cdot V_{CES}$, higher T_J or increased R_G | | 30 | ns | |
| t_{ri} | | | 30 | ns | |
| E_{on} | | | 0.65 | | mJ |
| $t_{d(off)}$ | | | 700 | | ns |
| t_{fi} | | | 520 | | ns |
| E_{off} | | | 6.5 | | mJ |
| R_{thJC} | | | | 0.83 | K/W |
| R_{thCK} | (TO-247) | | 0.25 | | K/W |

TO-247 AD (IXGH) Outline

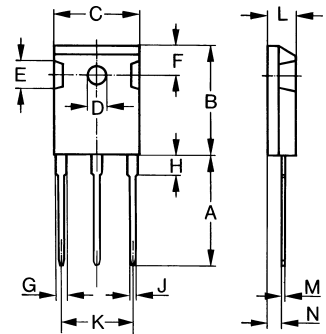

| Dim. | Millimeter | | Inches | |
|------|------------|-------|--------|-------|
| | Min. | Max. | Min. | Max. |
| A | 19.81 | 20.32 | 0.780 | 0.800 |
| B | 20.80 | 21.46 | 0.819 | 0.845 |
| C | 15.75 | 16.26 | 0.610 | 0.640 |
| D | 3.55 | 3.65 | 0.140 | 0.144 |
| E | 4.32 | 5.49 | 0.170 | 0.216 |
| F | 5.4 | 6.2 | 0.212 | 0.244 |
| G | 1.65 | 2.13 | 0.065 | 0.084 |
| H | - | 4.5 | - | 0.177 |
| J | 1.0 | 1.4 | 0.040 | 0.055 |
| K | 10.8 | 11.0 | 0.426 | 0.433 |
| L | 4.7 | 5.3 | 0.185 | 0.209 |
| M | 0.4 | 0.8 | 0.016 | 0.031 |
| N | 1.5 | 2.49 | 0.087 | 0.102 |

TO-268AA (D³ PAK)

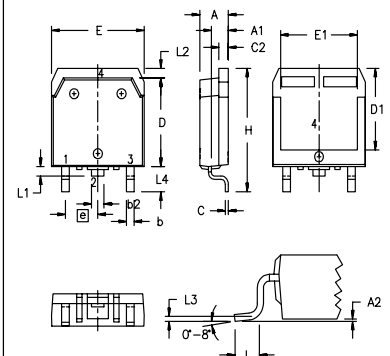

| Dim. | Millimeter | | Inches | |
|----------------|------------|-------|----------|------|
| | Min. | Max. | Min. | Max. |
| A | 4.9 | 5.1 | .193 | .201 |
| A ₁ | 2.7 | 2.9 | .106 | .114 |
| A ₂ | .02 | .25 | .001 | .010 |
| b | 1.15 | 1.45 | .045 | .057 |
| b ₂ | 1.9 | 2.1 | .75 | .83 |
| C | .4 | .65 | .016 | .026 |
| D | 13.80 | 14.00 | .543 | .551 |
| E | 15.85 | 16.05 | .624 | .632 |
| E ₁ | 13.3 | 13.6 | .524 | .535 |
| e | 5.45 BSC | | .215 BSC | |
| H | 18.70 | 19.10 | .736 | .752 |
| L | 2.40 | 2.70 | .094 | .106 |
| L ₁ | 1.20 | 1.40 | .047 | .055 |
| L ₂ | 1.00 | 1.15 | .039 | .045 |
| L ₃ | 0.25 BSC | | .010 BSC | |
| L ₄ | 3.80 | 4.10 | .150 | .161 |

Min. Recommended Footprint

