

REVISIONS																				
LTR	DESCRIPTION															DATE (YR-MO-DA)	APPROVED			
REV																				
SHEET																				
REV																				
SHEET																				
REV STATUS OF SHEETS	REV																			
	SHEET	1	2	3	4	5	6	7	8	9	10	11	12	13	14	15				
PMIC N/A	PREPARED BY <i>Rick C. Offin</i>					DEFENSE ELECTRONICS SUPPLY CENTER DAYTON, OHIO 45444														
STANDARDIZED MILITARY DRAWING	CHECKED BY <i>Charles E. Besore</i>					MICROCIRCUITS, LINEAR, DUAL POWER SUPPLY SUPERVISORS, MONOLITHIC SILICON														
	APPROVED BY <i>[Signature]</i>					SIZE	CAGE CODE													
	DRAWING APPROVAL DATE 18 DECEMBER 1990					A	67268	5962-90932												
THIS DRAWING IS AVAILABLE FOR USE BY ALL DEPARTMENTS AND AGENCIES OF THE DEPARTMENT OF DEFENSE	REVISION LEVEL					SHEET 1														
AMSC N/A																				

DESC FORM 193
SEP 87

U.S. GOVERNMENT PRINTING OFFICE: 1987 -- 748-129/60911
5962-E008

DISTRIBUTION STATEMENT A. Approved for public release; distribution is unlimited.

1. SCOPE

1.1 Scope. This drawing forms a part of a one part - one part number documentation system (see 6.6 herein). Two product assurance classes consisting of military high reliability (device classes B, Q, and M) and space application (device classes S and V), and a choice of case outlines and lead finishes are available and are reflected in the Part or Identifying Number (PIN). Device class M microcircuits represent non-JAN class B microcircuits in accordance with 1.2.1 of MIL-STD-883, "Provisions for the use of MIL-STD-883 in conjunction with compliant non-JAN devices". When available, a choice of radiation hardness assurance (RHA) levels are reflected in the PIN.

1.2 PIN. The PIN shall be as shown in the following example:

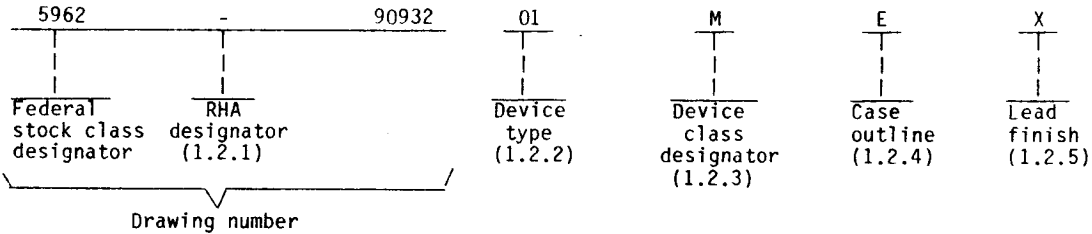

1.2.1 Radiation hardness assurance (RHA) designator. Device classes M, B, and S RHA marked devices shall meet the MIL-M-38510 specified RHA levels and shall be marked with the appropriate RHA designator. Device classes Q and V devices shall meet or exceed the electrical performance characteristics specified in table I herein after exposure to the specified irradiation levels specified in the absolute maximum ratings herein and the RHA marked device shall be marked in accordance with MIL-I-38535. A dash (-) indicates a non-RHA device.

1.2.2 Device type(s). The device type(s) shall identify the circuit function as follows:

<u>Device type</u>	<u>Generic number</u>	<u>Circuit function</u>
01	TL7770-5M	Dual power-supply supervisors
02	TL7770-12M	Dual power-supply supervisors
03	TL7770-15M	Dual power-supply supervisors

1.2.3 Device class designator. The device class designator shall be a single letter identifying the product assurance level as follows:

<u>Device class</u>	<u>Device requirements documentation</u>
M	Vendor self-certification to the requirements for non-JAN class B microcircuits in accordance with 1.2.1 of MIL-STD-883
B or S	Certification and qualification to MIL-M-38510
Q or V	Certification and qualification to MIL-I-38535

1.2.4 Case outline(s). For device classes M, B, and S, case outline(s) shall meet the requirements in appendix C of MIL-M-38510 and as listed below. For device classes Q and V, case outline(s) shall meet the requirements of MIL-I-38535, appendix C of MIL-M-38510, and as listed below.

<u>Outline letter</u>	<u>Case outline</u>
E	D-2 (16-lead, .840" x .310" x .200"), dual-in-line package
2	C-2 (20-terminal, .358" x .358" x .100"), square chip carrier package

STANDARDIZED MILITARY DRAWING DEFENSE ELECTRONICS SUPPLY CENTER DAYTON, OHIO 45444	SIZE A	5962-90932
	REVISION LEVEL	SHEET 2

1.2.5 Lead finish. The lead finish shall be as specified in MIL-M-38510 for classes M, B, and S or MIL-I-38535 for Classes Q and V. Finish letter "X" shall not be marked on the microcircuit or its packaging. The "X" designation is for use in specifications when lead finishes A, B, and C are considered acceptable and interchangeable without preference.

1.3 Absolute maximum ratings. 1/

Supply voltage (V_{CC}) 2/	- - - - -	20 V dc
Input voltage range (V_I): VSU1, VSU2, VS01, and VS02	- - - - -	-0.3 V dc to +18 V dc
Low level output current (I_{OL}), (RESET1 and RESET2)	- - - - -	20 mA
High level output current (I_{OH}), (RESET1 and RESET2)	- - - - -	-20 mA
Storage temperature range	- - - - -	-65°C to +150°C
Lead temperature soldering, 1.6 mm (0.0625 inch) from case for 10 seconds	- - - - -	260°C
Power dissipation (P_D) 3/	- - - - -	1375 mW
Thermal resistance, junction-to-case (θ_{JC})	- - - - -	See MIL-M-38510, appendix C
Junction temperature	- - - - -	-55°C to +150°C

1.4 Recommended operating conditions.

Supply voltage (V_{CC})	- - - - -	3.5 V dc minimum, 18 V dc maximum
Input voltage range (V_I): (RESIN1, RESIN2, VSU1, VSU2, VS01, VS02)	- - - - -	0 V dc minimum, 18 V dc maximum
Output voltage (V_O), (CT1 and CT2)	- - - - -	5 V dc maximum
Output sink current (I_O), (CT1 and CT2)	- - - - -	50 μ A maximum
High level output current (I_{OH}), (RESET1 and RESET2)	- - - - -	-16 mA maximum
Low level output current (I_{OL}), (RESET1 and RESET2)	- - - - -	16 mA maximum
Continuous output current (I_O), (SCR1 GATE DRIVE and SCR2 GATE DRIVE)	- - - - -	25 mA maximum
Ambient operating temperature (T_A)	- - - - -	-55°C to +125°C

2. APPLICABLE DOCUMENTS

2.1 Government specifications, standards, bulletin, and handbook. Unless otherwise specified, the following specifications, standards, bulletin, and handbook of the issue listed in that issue of the Department of Defense Index of Specifications and Standards specified in the solicitation, form a part of this drawing to the extent specified herein.

SPECIFICATIONS

MILITARY

- MIL-M-38510 - Microcircuits, General Specification for.
- MIL-I-38535 - Integrated Circuits, Manufacturing, General Specification for.

1/ Stresses above the absolute maximum rating may cause permanent damage to the device. Extended operation at the maximum levels may degrade performance and affect reliability.
 2/ All voltage values are with respect to the network ground terminal.
 3/ Above $T_A = +25^\circ\text{C}$ derate at a factor of 12.0 mW/°C.

STANDARDIZED MILITARY DRAWING DEFENSE ELECTRONICS SUPPLY CENTER DAYTON, OHIO 45444	SIZE A		5962-90932
		REVISION LEVEL	SHEET 3

DESC FORM 193A
SEP 87

* U.S. GOVERNMENT PRINTING OFFICE 1990-750-527R

STANDARDS

MILITARY

- MIL-STD-480 - Configuration Control-Engineering Changes, Deviations and Waivers.
- MIL-STD-883 - Test Methods and Procedures for Microelectronics.

BULLETIN

MILITARY

- MIL-BUL-103 - List of Standardized Military Drawings (SMD's).

HANDBOOK

MILITARY

- MIL-HDBK-780 - Standardized Military Drawings.

(Copies of the specifications, standards, bulletin, and handbook required by manufacturers in connection with specific acquisition functions should be obtained from the contracting activity or as directed by the contracting activity.)

2.2 Order of precedence. In the event of a conflict between the text of this drawing and the references cited herein, the text of this drawing shall take precedence.

3. REQUIREMENTS

3.1 Item requirements. The individual item requirements for device class M shall be in accordance with 1.2.1 of MIL-STD-883, "Provisions for the use of MIL-STD-883 in conjunction with compliant non-JAN devices" and as specified herein. The individual item requirements for device classes B and S shall be in accordance with MIL-M-38510 and as specified herein. For device classes B and S, a full electrical characterization table for each device type shall be included in this SMD. The individual item requirements for device classes Q and V shall be in accordance with MIL-I-38535 and as specified herein.

3.2 Design, construction, and physical dimensions. The design, construction, and physical dimensions shall be as specified in MIL-M-38510 for device classes M, B, and S and MIL-I-38535 for device classes Q and V and herein.

3.2.1 Case outline(s). The case outline(s) shall be in accordance with 1.2.4 herein.

3.2.2 Terminal connections. The terminal connections shall be as specified on figure 1.

3.2.3 Truth table. The truth table shall be as specified on figure 2.

3.2.4 Block diagram. The block diagram shall be as specified on figure 3.

3.3 Electrical performance characteristics and postirradiation parameter limits. Unless otherwise specified herein, the electrical performance characteristics and postirradiation parameter limits are as specified in table I and shall apply over the full ambient operating temperature range.

3.4 Electrical test requirements. The electrical test requirements shall be the subgroups specified in table IIA. The electrical tests for each subgroup are defined in table I.

3.5 Marking. The part shall be marked with the PIN listed in 1.2 herein. Marking for device class M shall be in accordance with MIL-STD-883 (see 3.1 herein). In addition, the manufacturer's PIN may also be marked as listed in MIL-BUL-103. Marking for device classes B and S shall be in accordance with MIL-M-38510. Marking for device classes Q and V shall be in accordance with MIL-I-38535.

STANDARDIZED MILITARY DRAWING DEFENSE ELECTRONICS SUPPLY CENTER DAYTON, OHIO 45444	SIZE A	5962-90932
	REVISION LEVEL	SHEET 4

DESC FORM 193A
SEP 87

* U.S. GOVERNMENT PRINTING OFFICE: 1990-750-527/R

TABLE I. Electrical performance characteristics.

Test	Symbol	Conditions -55°C < T _A < +125°C V _{CC} = 3.5 V to 18 V unless otherwise specified	Group A subgroups	Device type	Limits		Unit
					Min	Max	
High level output voltage, RESET	V _{OH}	I _{OH} = -15 mA	1,2,3	01,02, 03	V _{CC} -1.5	-	V
High level output voltage, SCR GATE DRIVER		I _{OH} = -20 mA	1,2,3	01,02, 03	V _{CC} -1.5	-	V
Low level output voltage, RESET	V _{OL}	I _{OL} = 15 mA	1,2,3	01,02, 03	-	0.4	V
Undervoltage threshold (negative going), VSU1	V _{T-}		1	01	4.50	4.632	V
			2,3		4.40	4.646	
			1	02	10.80	11.07	
			2,3		10.62	11.12	
			1	03	13.50	13.866	
			2,3		13.36	13.916	
Undervoltage threshold (negative going), VSU2	V _{T-}		1	01,02, 03	1.485	1.527	V
			2,3		1.460	1.542	
Overvoltage threshold	V _{T+}		1	01,02, 03	2.530	2.630	V
			2,3		2.480	2.680	
Input current, RESIN	I _I	V _I = 5.5 V or 0.4 V	1,2,3	01,02, 03		-10	μA
Input current, VSO		V _I = 2.4 V				2	
High level output current, RESET	I _{OH}	V _O = V _{CC}	1,2,3	01,02, 03		50	μA
Low level output current, RESET	I _{OL}	V _O = 1 V	1,2,3	01,02, 03		-50	μA

STANDARDIZED MILITARY DRAWING DEFENSE ELECTRONICS SUPPLY CENTER DAYTON, OHIO 45444	SIZE A		5962-90932
		REVISION LEVEL	SHEET 5

DESC FORM 193A
SEP 87

* U.S. GOVERNMENT PRINTING OFFICE: 1990-750-527R

TABLE I. Electrical performance characteristics - Continued.

Test	Symbol	Conditions -55°C ≤ T _A ≤ +125°C V _{CC} = 3.5 V to 18 V unless otherwise specified	Group A subgroups	Device type	Limits		Unit
					Min	Max	
Peak output current, SCR GATE DRIVE	I _{OP}	Duration = 1 ms	1,2,3	01,02,03	-250		mA
Supply current	I _{CC}	VSU1 and VSU2 at > V _{T+} , RESIN1 and RESIN2 at V _{CC} , VS01 and VS02 at 0 V	1	01,02,03		5	mA
			2,3			6.5	
Functional tests		See 4.4.1b	7,8	01,02,03			
Propagation delay $\frac{1}{2}$ time, low-to-high level output from RESIN to RESET	t _{PLH}	See figure 4, T _A = +25°C	9	01,02,03		500	ns
Propagation delay $\frac{1}{2}$ time, high-to-low level output from RESIN to RESET	t _{PHL}	See figure 4, T _A = +25°C	9	01,02,03		500	ns
Rise time, RESET	$\frac{1}{2}$ t _R	See figure 4, T _A = +25°C	9	01,02,03		75	ns
Fall time, RESET	$\frac{1}{2}$ t _F	See figure 4, T _A = +25°C	9	01,02,03		50	ns

$\frac{1}{2}$ / If not tested, shall be guaranteed to the limits specified in table I herein.

3.5.1 Certification/compliance mark. The compliance mark for device class M shall be a "C" as required in MIL-STD-883 (see 3.1 herein). The certification mark for device classes B and S shall be a "J" or "JAN" as required in MIL-M-38510. The certification mark for device classes Q and V shall be a "QML" as required in MIL-I-38535.

3.6 Certificate of compliance. For device class M, a certificate of compliance shall be required from a manufacturer in order to be listed as an approved source of supply in MIL-BUL-103 (see 6.7.3 herein). For device classes Q and V, a certificate of compliance shall be required from a QML-38535 listed manufacturer in order to supply to the requirements of this drawing (see 6.7.2 herein). The certificate of compliance submitted to DESC-ECS prior to listing as an approved source of supply for this drawing shall affirm that the manufacturer's product meets, for device class M the requirements of MIL-STD-883 (see 3.1 herein), or for device classes Q and V, the requirements of MIL-I-38535 and the requirements herein.

STANDARDIZED MILITARY DRAWING DEFENSE ELECTRONICS SUPPLY CENTER DAYTON, OHIO 45444	SIZE A	5962-90932
	REVISION LEVEL	SHEET 6

Device types	01, 02, 03	
Case outlines	E	2
Terminal number	Terminal symbol	
1	RESIN1	NC
2	CT1	RESIN1
3	RESET1	CT1
4	RESET1	RESET1
5	VSU1	RESET1
6	VS01	NC
7	SCR DRIVE1	VSU1
8	GND	VS01
9	SCR DRIVE2	SCR DRIVE1
10	VS02	GND
11	VSU2	NC
12	RESET2	SCR DRIVE2
13	RESET2	VS02
14	CT2	VSU2
15	RESIN2	RESET2
16	V _{CC}	NC
17	---	RESET2
18	---	CT2
19	---	RESIN2
20	---	V _{CC}

NC = No connection

FIGURE 1. Terminal connections.

STANDARDIZED MILITARY DRAWING DEFENSE ELECTRONICS SUPPLY CENTER DAYTON, OHIO 45444	SIZE A		5962-90932
		REVISION LEVEL	SHEET 7

DESC FORM 193A
SEP 87

U.S. GOVERNMENT PRINTING OFFICE 1990-750-527H

Input		Output	
V _{SU}	RESIN	RESET	RESET
X	L	H	L
< V _{T-}	H	H	L
> V _{T+}	H	L	H

X = Don't care
H = High
L = Low

FIGURE 2. Truth table.

STANDARDIZED MILITARY DRAWING DEFENSE ELECTRONICS SUPPLY CENTER DAYTON, OHIO 45444	SIZE A		5962-90932
		REVISION LEVEL	SHEET 8

DESC FORM 193A
SEP 87

U.S. GOVERNMENT PRINTING OFFICE: 1990-750-527/R

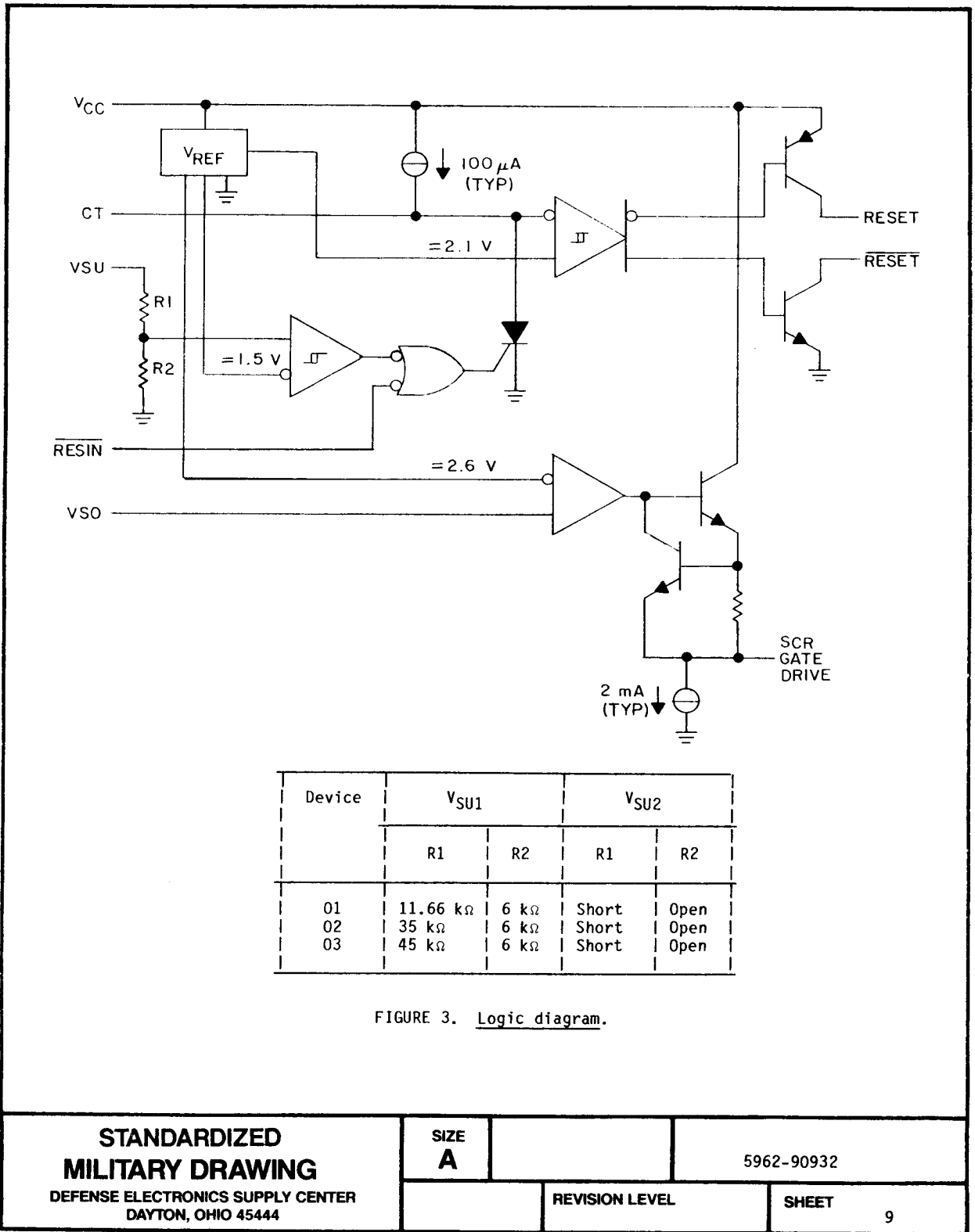

Device	V_{SU1}		V_{SU2}	
	R1	R2	R1	R2
01	11.66 k Ω	6 k Ω	Short	Open
02	35 k Ω	6 k Ω	Short	Open
03	45 k Ω	6 k Ω	Short	Open

FIGURE 3. Logic diagram.

STANDARDIZED MILITARY DRAWING DEFENSE ELECTRONICS SUPPLY CENTER DAYTON, OHIO 45444	SIZE A		5962-90932
		REVISION LEVEL	SHEET 9

DESC FORM 193A
SEP 87

* U.S. GOVERNMENT PRINTING OFFICE 1990-750-527R

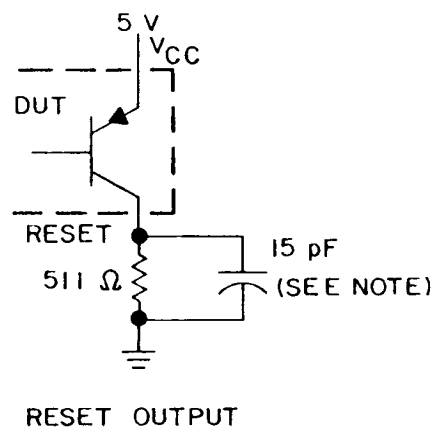
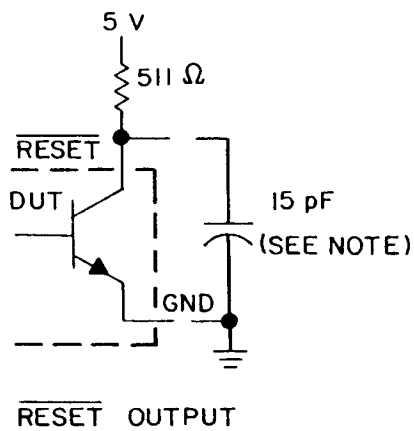

NOTE: Includes jig and probe capacitance.

FIGURE 4. RESET and RESET output test circuits.

STANDARDIZED MILITARY DRAWING DEFENSE ELECTRONICS SUPPLY CENTER DAYTON, OHIO 45444	SIZE A		5962-90932
		REVISION LEVEL	SHEET 10

DESC FORM 193A
SEP 87

U. S. GOVERNMENT PRINTING OFFICE: 1988-549-904

3.7 Certificate of conformance. A certificate of conformance as required for device class M in MIL-STD-883 (see 3.1 herein), device classes B and S in MIL-M-38510, or for device classes Q and V in MIL-I-38535 shall be provided with each lot of microcircuits delivered to this drawing.

3.8 Notification of change for device class M. For device class M, notification to DESC-ECS of change of product (see 6.2 herein) involving devices acquired to this drawing is required for any change as defined in MIL-STD-480.

3.9 Verification and review for device class M. For device class M, DESC, DESC's agent, and the acquiring activity retain the option to review the manufacturer's facility and applicable required documentation. Offshore documentation shall be made available onshore at the option of the reviewer.

3.10 Microcircuit group assignment for device classes M, B, and S. Device classes M, B, and S devices covered by this drawing shall be in microcircuit group number 88 (see MIL-M-38510, appendix E).

3.11 Serialization for device class S. All device class S devices shall be serialized in accordance with MIL-M-38510.

4. QUALITY ASSURANCE PROVISIONS

4.1 Sampling and inspection. For device class M, sampling and inspection procedures shall be in accordance with section 4 of MIL-M-38510 to the extent specified in MIL-STD-883 (see 3.1 herein). For device classes B and S, sampling and inspection procedures shall be in accordance with MIL-M-38510 and method 5005 of MIL-STD-883, except as modified herein. For device classes Q and V, sampling and inspection procedures shall be in accordance with MIL-I-38535.

4.2 Screening. For device class M, screening shall be in accordance with method 5004 of MIL-STD-883, and shall be conducted on all devices prior to quality conformance inspection. For device classes B and S, screening shall be in accordance with method 5004 of MIL-STD-883, and shall be conducted on all devices prior to qualification and quality conformance inspection. For device classes Q and V, screening shall be in accordance with MIL-I-38535, and shall be conducted on all devices prior to qualification and technology conformance inspection. The following additional criteria shall apply.

a. Burn-in test, method 1015 of MIL-STD-883.

(1) Test condition B or D. For device class M, the test circuit shall be submitted to DESC-ECS for review with the certificate of compliance. For device classes B and S, the test circuit shall be submitted to the qualifying activity. For device classes Q and V, the test circuit shall be submitted to DESC-ECS with the certificate of compliance and under the control of the device manufacturer's technical review board (TRB) in accordance with MIL-I-38535.

(2) $T_A = +125^{\circ}\text{C}$, minimum.

b. Device class M interim and final electrical test parameters shall be as specified in table IIA herein, except interim electrical parameter tests prior to burn-in are optional at the discretion of the manufacturer.

c. Device classes B, S, Q, and V interim and final electrical test parameters shall be as specified in table IIA herein.

4.2.1 Additional screening for device class V. Additional screening for device class V beyond the requirements of device class Q shall be as specified in appendix B of MIL-I-38535 and as detailed in table IIB herein. These additional screens may be used to satisfy space system requirements and shall be reflected in the PIN.

STANDARDIZED MILITARY DRAWING DEFENSE ELECTRONICS SUPPLY CENTER DAYTON, OHIO 45444	SIZE A		5962-90932
		REVISION LEVEL	SHEET 11

DESC FORM 193A
SEP 87

* U.S. GOVERNMENT PRINTING OFFICE: 1990-750-527R

TABLE IIA. Electrical test requirements.

Test requirements	Subgroups (per method 5005, table I)			Subgroups (per MIL-I-38535, table III)	
	Device class M	Device class B	Device class S	Device class Q	Device class V
Interim electrical parameters (see 4.2)	1	1	1	1	1
Final electrical parameters (see 4.2)	1,2, 1/ 3,7,8,9	1,2, 2/ 3,7,8,9	1,2, 2/ 3,7,8,9	1,2, 1/ 3,7,8,9	1,2, 1/ 3,7,8,9
Group A test requirements (see 4.4)	1,2,3, 7,8,9	1,2,3, 7,8,9	1,2,3, 7,8,9	1,2,3, 7,8,9	1,2,3, 7,8,9
Group B end-point electrical parameters (see 4.4)	---	---	1,2,3, 7,8,9	---	1,2,3, 7,8,9
Group C end-point electrical parameters (see 4.4)	1	1	---	1	---
Group D end-point electrical parameters (see 4.4)	1	1	1	1	1
Group E end-point electrical parameters (see 4.4)	1,7,9	1,7,9	1,7,9	1,7,9	1,7,9

1/ PDA applies to subgroup 1.

2/ PDA applies to subgroups 1 and 7.

4.3 Qualification inspection.

4.3.1 Qualification inspection for device classes B and S. Qualification inspection for device classes B and S shall be in accordance with MIL-M-38510. Inspections to be performed shall be those specified in method 5005 of MIL-STD-883 and herein for groups A, B, C, D, and E inspections (see 4.4.1 through 4.4.5).

4.3.2 Qualification inspection for device classes Q and V. Qualification inspection for device classes Q and V shall be in accordance with MIL-I-38535. Inspections to be performed shall be those specified in MIL-I-38535 and herein for groups A, B, C, D, and E inspections (see 4.4.1 through 4.4.5).

4.4 Conformance inspection. Quality conformance inspection for device class M shall be in accordance with MIL-STD-883 (see 3.1 herein) and as specified herein. Quality conformance inspection for device classes B and S shall be in accordance with MIL-M-38510 and as specified herein. Inspections to be performed for device classes M, B, and S shall be those specified in method 5005 of MIL-STD-883 and herein for groups A, B, C, D, and E inspections (see 4.4.1 through 4.4.5). Technology conformance inspection for classes Q and V shall be in accordance with MIL-I-38535 including groups A, B, C, D, and E inspections and as specified herein.

STANDARDIZED MILITARY DRAWING DEFENSE ELECTRONICS SUPPLY CENTER DAYTON, OHIO 45444	SIZE A	5962-90932
	REVISION LEVEL	SHEET 12

TABLE IIB. Additional screening for device class V.

Test	MIL-STD-883, test method	Lot requirement
Particle impact noise detection	2020	100%
Internal visual	2010, condition A or approved alternate	100%
Nondestructive bond pull	2023 or approved alternate	100%
Reverse bias burn-in	1015	100%
Burn-in	1015, total of 240 hours at +125°C	100%
Radiographic	2012	100%

4.4.1 Group A inspection.

- a. Tests shall be as specified in table IIA herein.
- b. For device class M, subgroups 7 and 8 tests shall be sufficient to verify the truth table. For device classes B and S, subgroups 7 and 8 tests shall be sufficient to verify the truth table as approved by the qualifying activity. For device classes Q and V, subgroups 7 and 8 shall include verifying the functionality of the device.

4.4.2 Group B inspection. The group B inspection end-point electrical parameters shall be as specified in table IIA herein.

4.4.3 Group C inspection.

- a. End-point electrical parameters shall be as specified in table IIA herein.
- b. Steady-state life test conditions, method 1005 of MIL-STD-883:
 - (1) Test condition B or D. For device class M, the test circuit shall be submitted to DESC-ECS for review with the certificate of compliance. For device classes B and S, the test circuit shall be submitted to the qualifying activity. For device classes Q and V, the test circuit shall be submitted to DESC-ECS with the certificate of compliance and under the control of the device manufacturer's TRB in accordance with MIL-I-38535.
 - (2) $T_A = +125^\circ\text{C}$, minimum.
 - (3) Test duration: 1,000 hours, except as permitted by method 1005 of MIL-STD-883.

4.4.4 Group D inspection. The group D inspection end-point electrical parameters shall be as specified in table IIA herein.

STANDARDIZED MILITARY DRAWING DEFENSE ELECTRONICS SUPPLY CENTER DAYTON, OHIO 45444	SIZE A	5962-90932
	REVISION LEVEL	SHEET 13

DESC FORM 193A
SEP 87

* U.S. GOVERNMENT PRINTING OFFICE 1990-750-527R

4.4.5 Group E inspection. Group E inspection is required only for parts intended to be marked as radiation hardness assured (see 3.5 herein). RHA levels for device classes B and S shall be M, D, R, and H, and for device class M shall be M and D. RHA quality conformance inspection sample tests shall be performed at the RHA level specified in the acquisition document. RHA tests for device classes Q and V shall be performed in accordance with MIL-I-38535 and 1.2.1 herein.

- a. RHA tests for device classes B and S for levels M, D, R, and H or for device class M for levels M and D shall be performed through each level to determine at what levels the devices meet the RHA requirements. These RHA tests shall be performed for initial qualification and after design or process changes which may affect the RHA performance of the device.
- b. End-point electrical parameters shall be as specified in table IIA herein.
- c. Prior to total dose irradiation, each selected sample shall be assembled in its qualified package. It shall pass the specified group A electrical parameters in table I for subgroups specified in table IIA herein.
- d. For device classes M, B, and S, the devices shall be subjected to radiation hardness assured tests as specified in MIL-M-38510 for RHA level being tested, and meet the postirradiation end-point electrical parameter limits as defined in table I at $T_A = +25^\circ\text{C} \pm 5$ percent, after exposure.
- e. Prior to and during total dose irradiation testing, the devices shall be biased to establish a worst case condition as specified in the radiation exposure circuit.
 - (1) Inputs tested high, $V_{CC} =$ volts dc, $R_{CC} = \Omega +5\%$, $V_{IN} =$ volts dc, $R_{IN} = \Omega +20\%$, and all outputs are open.
 - (2) Inputs tested low, $V_{CC} =$ volts dc, $R_{CC} = \Omega +5\%$, $V_{IN} = 0.0$ V dc, and all outputs are open.
- f. For device classes M, B, and S, subgroups 1 and 2 in table V, method 5005 of MIL-STD-883 shall be tested as appropriate for device construction.
- g. When specified in the purchase order or contract, a copy of the RHA delta limits shall be supplied.

5. PACKAGING

5.1 Packaging requirements. The requirements for packaging shall be in accordance with MIL-M-38510 for device classes M, B, and S, and MIL-I-38535 for device classes Q and V.

6. NOTES

6.1 Intended use. Microcircuits conforming to this drawing are intended for use for Government microcircuit applications (original equipment), design applications, and logistics purposes.

6.1.1 Replaceability. Microcircuits covered by this drawing will replace the same generic device covered by a contractor-prepared specification or drawing.

6.1.2 Substitutability. Device classes B and Q devices will replace device class M devices.

6.2 Configuration control of SMD's. All proposed changes to existing SMD's will be coordinated with the users of record for the individual documents. This coordination will be accomplished in accordance with MIL-STD-481 using DD Form 1693, Engineering Change Proposal (Short Form).

STANDARDIZED MILITARY DRAWING DEFENSE ELECTRONICS SUPPLY CENTER DAYTON, OHIO 45444	SIZE A	5962-90932
	REVISION LEVEL	SHEET 14

DESC FORM 193A
SEP 87

• U.S. GOVERNMENT PRINTING OFFICE: 1990 750-527R

6.3 Record of users. Military and industrial users shall inform Defense Electronics Supply Center when a system application requires configuration control and which SMD's are applicable to that system. DESC will maintain a record of users and this list will be used for coordination and distribution of changes to the drawings. Users of drawings covering microelectronic devices (FSC 5962) should contact DESC-ECS, telephone (513) 296-6022.

6.4 Comments. Comments on this drawing should be directed to DESC-ECS, Dayton, Ohio 45444, or telephone (513) 296-5375.

6.5 Symbols, definitions, and functional descriptions.

6.6 One part - one part number system. The one part - one part number system described below has been developed to allow for transitions between identical generic devices covered by the four major microcircuit requirements documents (MIL-M-38510, MIL-H-38534, MIL-I-38535, and 1.2.1 of MIL-STD-883) without the necessity for the generation of unique PIN's. The four military requirements documents represent different class levels, and previously when a device manufacturer upgraded military product from one class level to another, the benefits of the upgraded product were unavailable to the Original Equipment Manufacturer (OEM), that was contractually locked into the original unique PIN. By establishing a one part number system covering all four documents, the OEM can acquire to the highest class level available for a given generic device to meet system needs without modifying the original contract parts selection criteria.

<u>Military documentation format</u>	<u>Example PIN under new system</u>	<u>Manufacturing source listing</u>	<u>Document listing</u>
New MIL-M-38510 Military Detail Specifications (in the SMD format)	5962-XXXXZZ(B or S)YY	QPL-38510 (Part 1 or 2)	MIL-BUL-103
New MIL-H-38534 Standardized Military Drawings	5962-XXXXZZ(H or K)YY	QML-38534	MIL-BUL-103
New MIL-I-38535 Standardized Military Drawings	5962-XXXXZZ(Q or V)YY	QML-38535	MIL-BUL-103
New 1.2.1 of MIL-STD-883 Standardized Military Drawings	5962-XXXXZZ(M)YY	MIL-BUL-103	MIL-BUL-103

6.7 Sources of supply.

6.7.1 Sources of supply for device classes B and S. Sources of supply for device classes B and S are listed in QPL-38510.

6.7.2 Sources of supply for device classes Q and V. Sources of supply for device classes Q and V are listed in QML-38535. The vendors listed in QML-38535 have submitted a certificate of compliance (see 3.6 herein) to DESC-ECS and have agreed to this drawing.

6.7.3 Approved sources of supply for device class M. Approved sources of supply for class M are listed in MIL-BUL-103. The vendors listed in MIL-BUL-103 have agreed to this drawing and a certificate of compliance (see 3.6 herein) has been submitted to and accepted by DESC-ECS.

STANDARDIZED MILITARY DRAWING DEFENSE ELECTRONICS SUPPLY CENTER DAYTON, OHIO 45444	SIZE A	5962-90932
	REVISION LEVEL	SHEET 15

DESC FORM 193A
SEP 87

* U.S. GOVERNMENT PRINTING OFFICE 1990-750-527R